



BMW Motorrad



Rider's Manual (US Model)

R nineT

Motorcycle/Dealer Data

Motorcycle data

Model

Vehicle identification number

Color number

Initial registration

License plate

Dealer Data

Contact in Service

Ms./Mr.

Phone number

Dealer's address/phone number (company stamp)

Welcome to BMW

Congratulations on choosing a motorcycle from BMW Motorrad and welcome to the community of BMW motorcycle owners and riders. Familiarize yourself with your new motorcycle so that you can ride it safely and confidently in all highway traffic situations.

About this Rider's Manual

Please read this Rider's Manual carefully before starting to use your new BMW. It contains important information on how to operate the controls and how to get the most benefit from your BMW's advanced technical features.

In addition, it contains information on maintenance and care to help you maintain your vehicle's reliability and safety, as well as its value.

Suggestions and complaints

If you have any questions concerning your motorcycle, your authorized BMW Motorrad retailer is always happy to provide advice and assistance.

We wish you many miles of safe and enjoyable riding on your BMW

BMW Motorrad.

01 41 8 550 817



Table of Contents

1 General instructions	5	Fuel reserve	22	5 Anti-theft alarm system DWA	43
Overview	6	Warning lamps	23	Overview	44
Abbreviations and symbols	6	4 Operation	29	Activation	44
Equipment	7	Steering and ignition lock	30	Alarm function.....	46
Technical data	7	EWS Electronic immobilizer	31	Deactivation	47
Notice concerning current status	7	Clock	31	Programming.....	48
2 Overviews	9	Display	32	Logging on remote control	49
General view, left side	11	Lights	33	Synchronizing	50
General view, right side	13	Turn indicators	33	Battery	51
Multifunction switch, left	14	Hazard warning flashers	34	6 Riding	53
Multifunction switch, right	15	Emergency on/off switch (kill switch)	35	Safety instructions	54
Underneath seat	16	Clutch	35	Checklist	55
Instrument cluster	17	Brakes	36	Starting.....	56
3 Displays	19	Heated handlebar grips	36	Breaking in	57
Warning and indicator lamps	20	Mirrors	37	Brakes	58
Multifunction display	21	Spring preload	38	Parking your motorcycle	59
Meaning of symbols.....	22	Damping	38	Refueling	60
Service display	22	Tires	39	Fastening motorcycle for transport	61
		Headlight.....	39		
		Rider and passenger seats	40		

7 Technology in detail	63	10 Care	105	Weights	122
Brake system with BMW Motorrad ABS	64	Care products	106	Performance data	123
8 Maintenance	67	Washing your vehicle.....	106	Anti-theft alarm system ...	123
General instructions	68	Cleaning sensitive vehicle parts	106	Remote control.....	124
Onboard tool kit	68	Paint care	107	12 Service	125
Front wheel stand	68	Storing motorcycle	108	Reporting safety defects	126
Rear-wheel stand	70	Protective wax coating	108	BMW Motorrad Service ...	127
Engine oil	71	Returning motorcycle to use	108	BMW Motorrad Mobility Services	127
Brake system	72	11 Technical data	109	Maintenance procedures	127
Clutch	77	Troubleshooting chart.....	110	Confirmation of maintenance work.....	129
Wheel rims and tires	77	Threaded fasteners	111	Confirmation of service....	134
Wheels	77	Engine	113	13 Index	136
Headlight.....	86	Fuel	114		
Bulbs.....	87	Engine oil	115		
Jump-starting	90	Clutch	115		
Battery	91	Transmission	116		
9 Accessories	95	Rear-wheel drive	116		
General instructions	96	Suspension	117		
Onboard power sockets.....	96	Brakes	118		
Luggage	97	Wheels and tires	119		
Passenger frame	97	Electrical system	120		
Installing passenger frame.....	101	Frame	121		
		Dimensions	122		

General instructions

Overview	6
Abbreviations and symbols	6
Equipment	7
Technical data	7
Notice concerning current status	7

Overview

We have placed great importance on good orientation when using this Rider's Manual. You'll find special topics most quickly by using the extensive index at the end of the manual. You can find a first overview of your motorcycle in Chapter 2. All maintenance and repair work carried out on your vehicle will be documented in Chapter 11. Proof of the maintenance work performed is a prerequisite for generous treatment of claims.

When the time comes to sell your BMW, remember to hand over this Rider's Manual; it is an important part of the motorcycle.

Abbreviations and symbols



Indicates warnings that it is imperative to observe for your own safety and the safety of others, and to protect your product against damage.



Special information on operating and inspecting your motorcycle as well as maintenance and adjustment procedures.



Indicates the end of an item of information.



Instruction.



Result of an activity.



Reference to a page with more detailed information.



Indicates the end of accessory or equipment-dependent information.



Tightening torque.



Technical data.

OE

Optional equipment
BMW Motorrad optional extras are already completely installed during motorcycle production.

OA

Optional accessory
BMW optional accessories can be purchased and installed at your authorized BMW Motorrad retailer.

EWS

Electronic immobilizer.

DWA

Anti-theft alarm.

ABS Anti-Lock Brake System.

Equipment

When you ordered your BMW motorcycle, you chose various items of custom equipment. This Rider's Manual describes optional equipment (OE) offered by BMW and selected optional accessories (OA). This explains why the manual may also contain descriptions of equipment which you have not ordered. Please note, too, that your motorcycle might not be exactly as illustrated in this manual on account of country-specific differences.

If your motorcycle comes with equipment not described here, you can find the descriptions in a separate manual.

Technical data

All dimensions, weights and outputs in the Rider's Manual relate to the German DIN standards and comply with their tolerance specifications. Versions for individual countries may differ.

Notice concerning current status





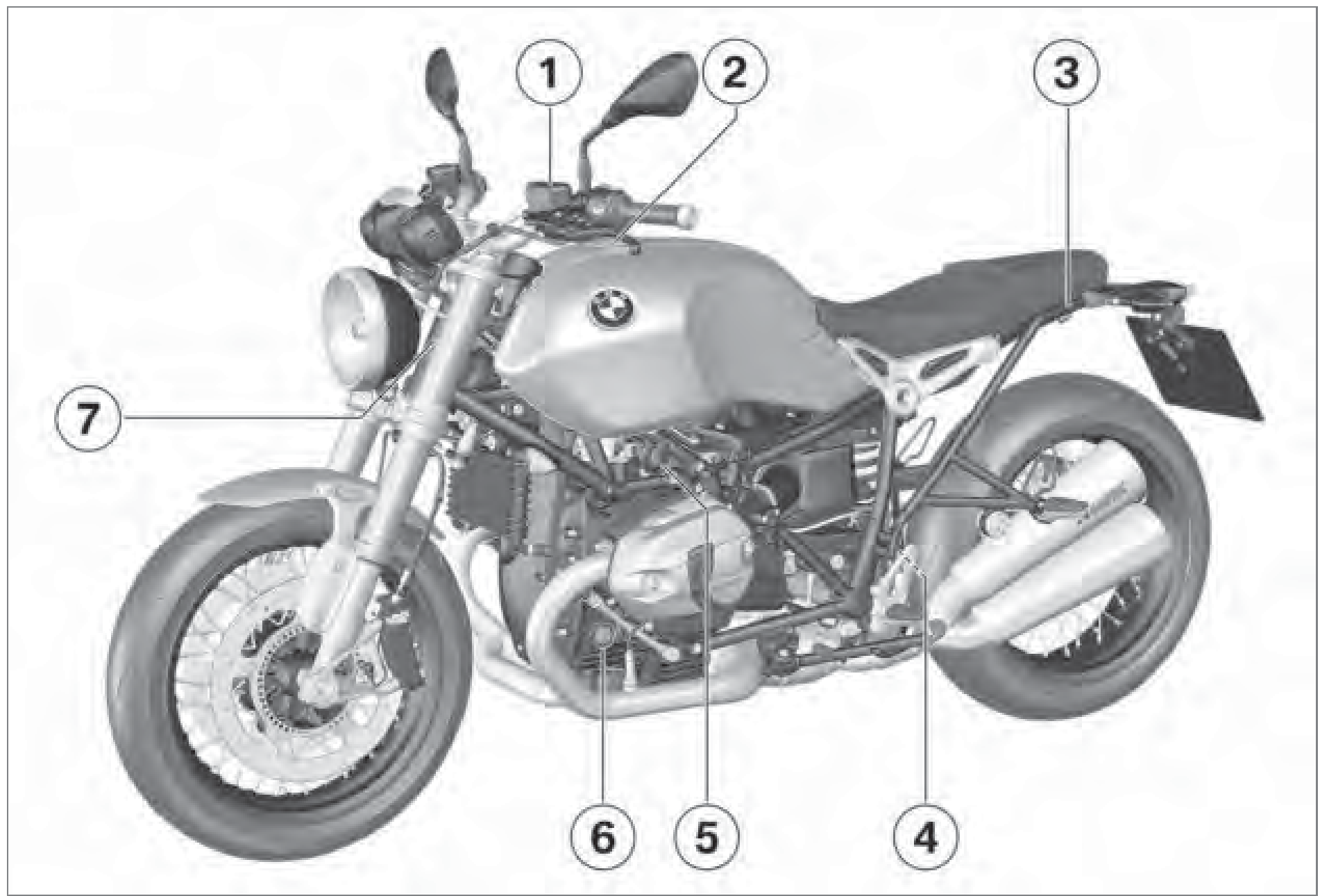

The high safety and quality standards of BMW motorcycles are maintained by constant development work on design, equipment and accessories. For this reason, aspects of your motorcycle may vary from the descriptions in this Rider's Manual. In addition, BMW Motorrad cannot guarantee the total absence of errors. We hope you will appreciate that no claims can be recognized based on the data, illustrations or descriptions in this manual.

Overviews

General view, left side.....	11
General view, right side	13
Multifunction switch, left	14
Multifunction switch, right.....	15
Underneath seat	16
Instrument cluster	17



General view, left side

- 1** Check clutch function
( 77)
- 2** Refueling ( 60)
- 3** Remove passenger frame
( 97)
- 4** Adjusting damping on rear wheel ( 38)
- 5** Onboard power sockets
( 96)
- 6** Check engine oil level
( 71)
- 7** Type plate (on left on steering-head bearing)

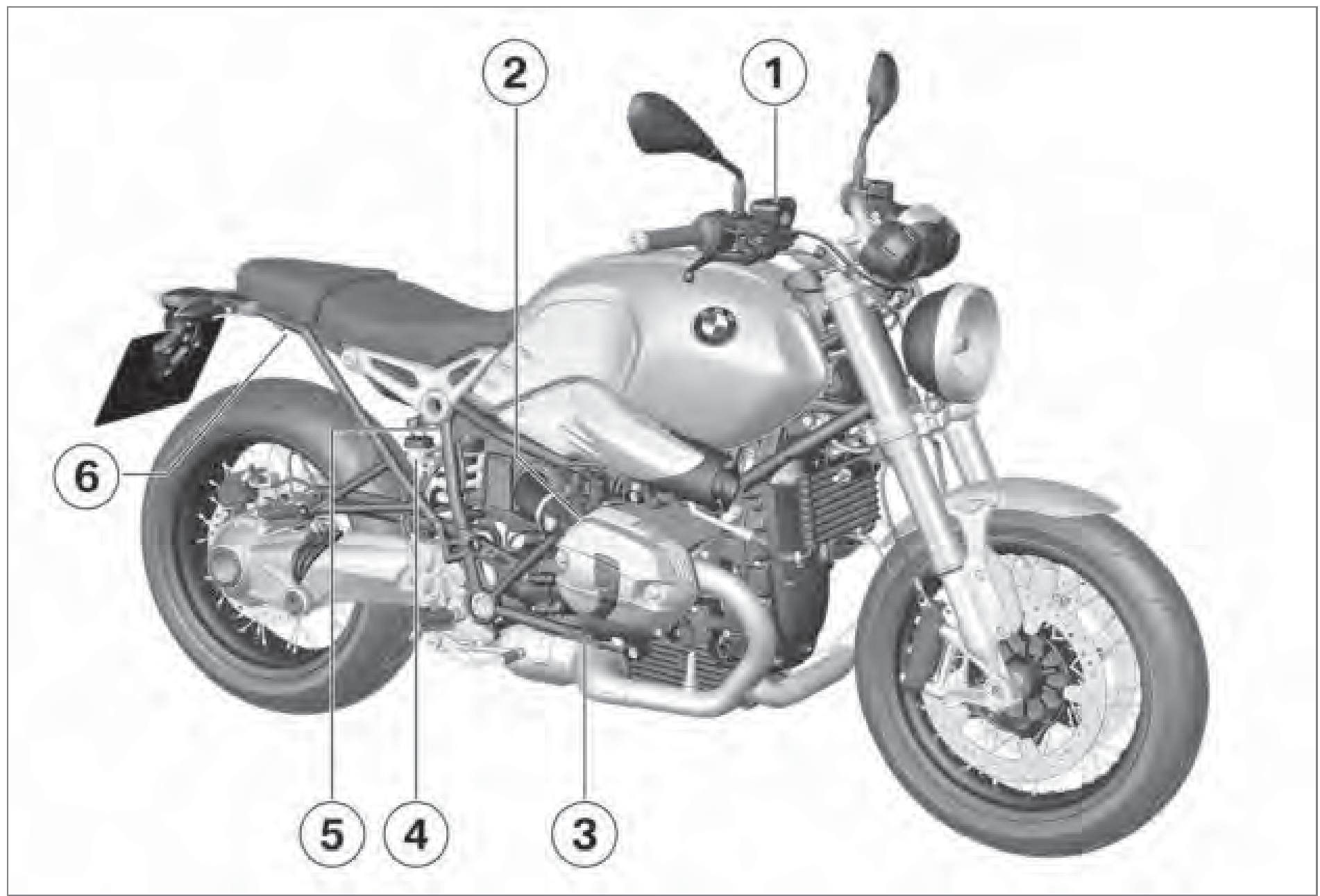

General view, right side

- 1** Check front brake fluid level (➡ 75)
- 2** Top up engine oil (➡ 72)
- 3** Vehicle Identification Number (at front right at bottom on rear frame)
- 4** Checking rear brake fluid level (➡ 76)
- 5** Adjusting spring preload (➡ 38)
- 6** Removing passenger seat (➡ 41)

Multifunction switch, left

- 1 Multifunction display (➡ 21)
- 2 High-beam headlight and headlight flasher (➡ 33)
- 3 Hazard warning flashers (➡ 34)
- 4 Turn indicators (➡ 33)
- 5 Horn

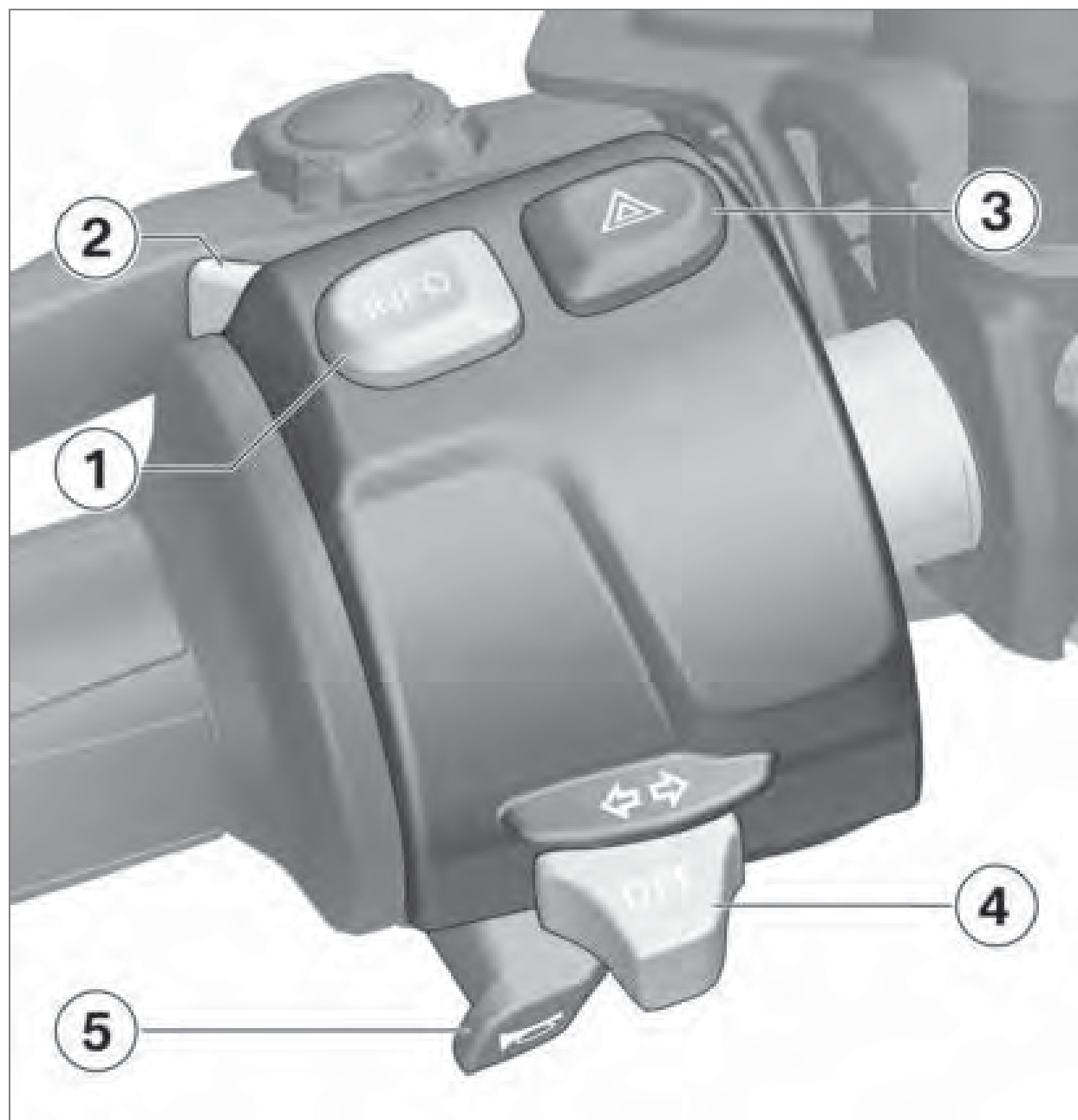

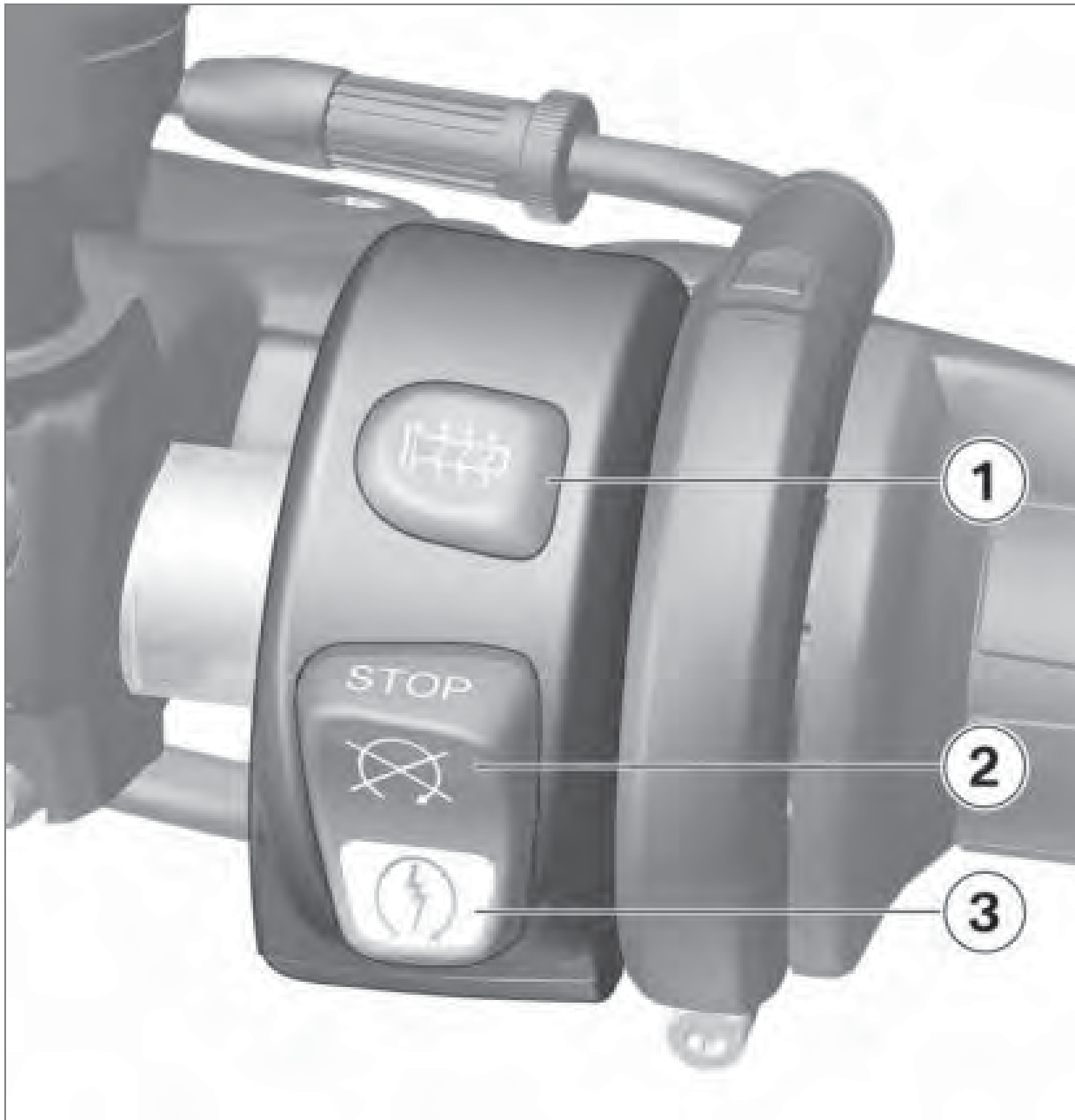

Multifunction switch, right

- 1** – with heated grips^{OA}
Operating heated grips (➡ 36)
- 2** Emergency on/off switch
(kill switch) (➡ 35)
- 3** Starter button (➡ 56)

Underneath seat

- 1 Rider's Manual (US Model)
- 2 Payload table
- 3 Onboard tool kit (→ 68)
- 4 Tire inflation pressure table
- 5 Positive battery connection point (→ 90)

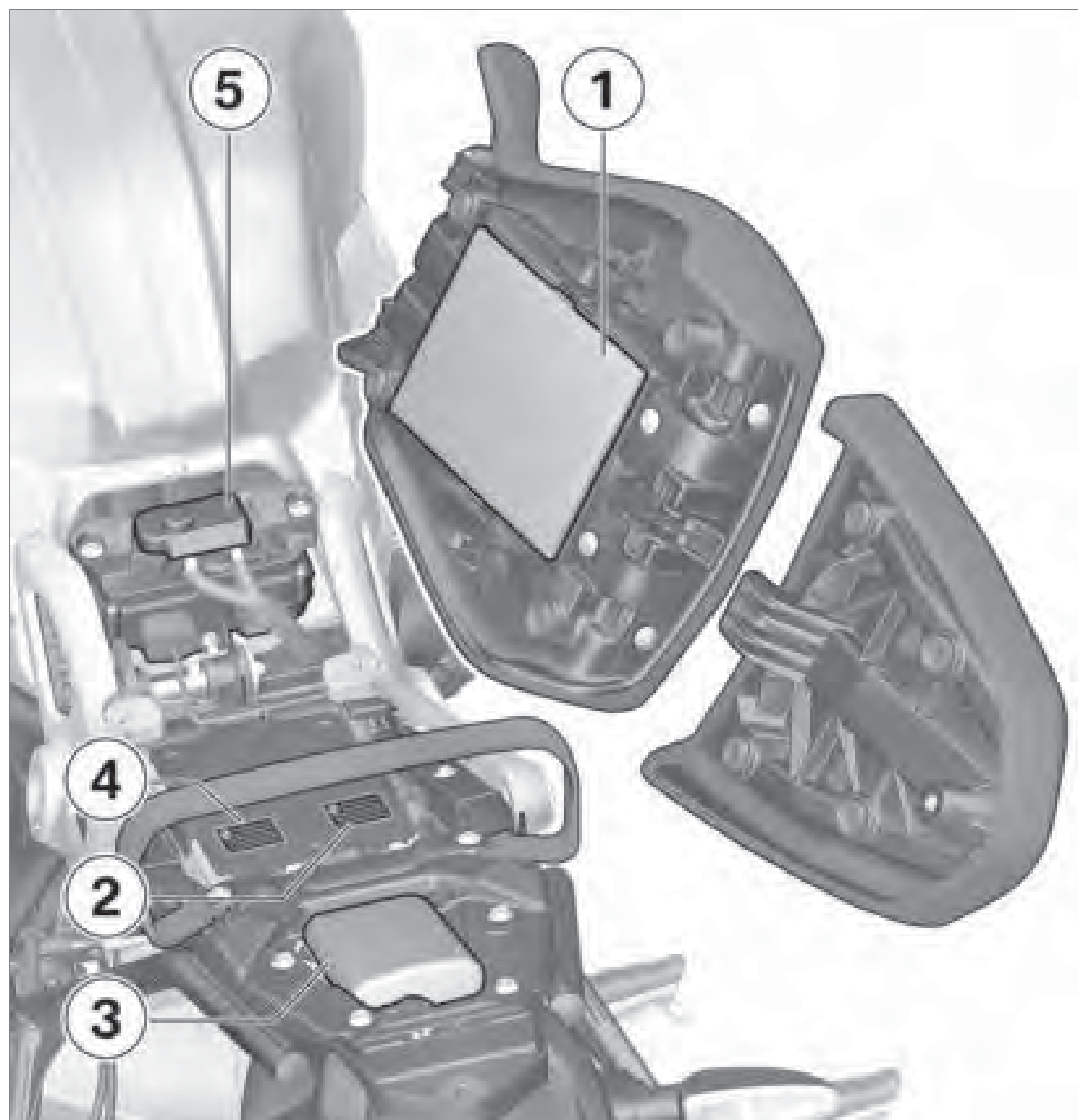

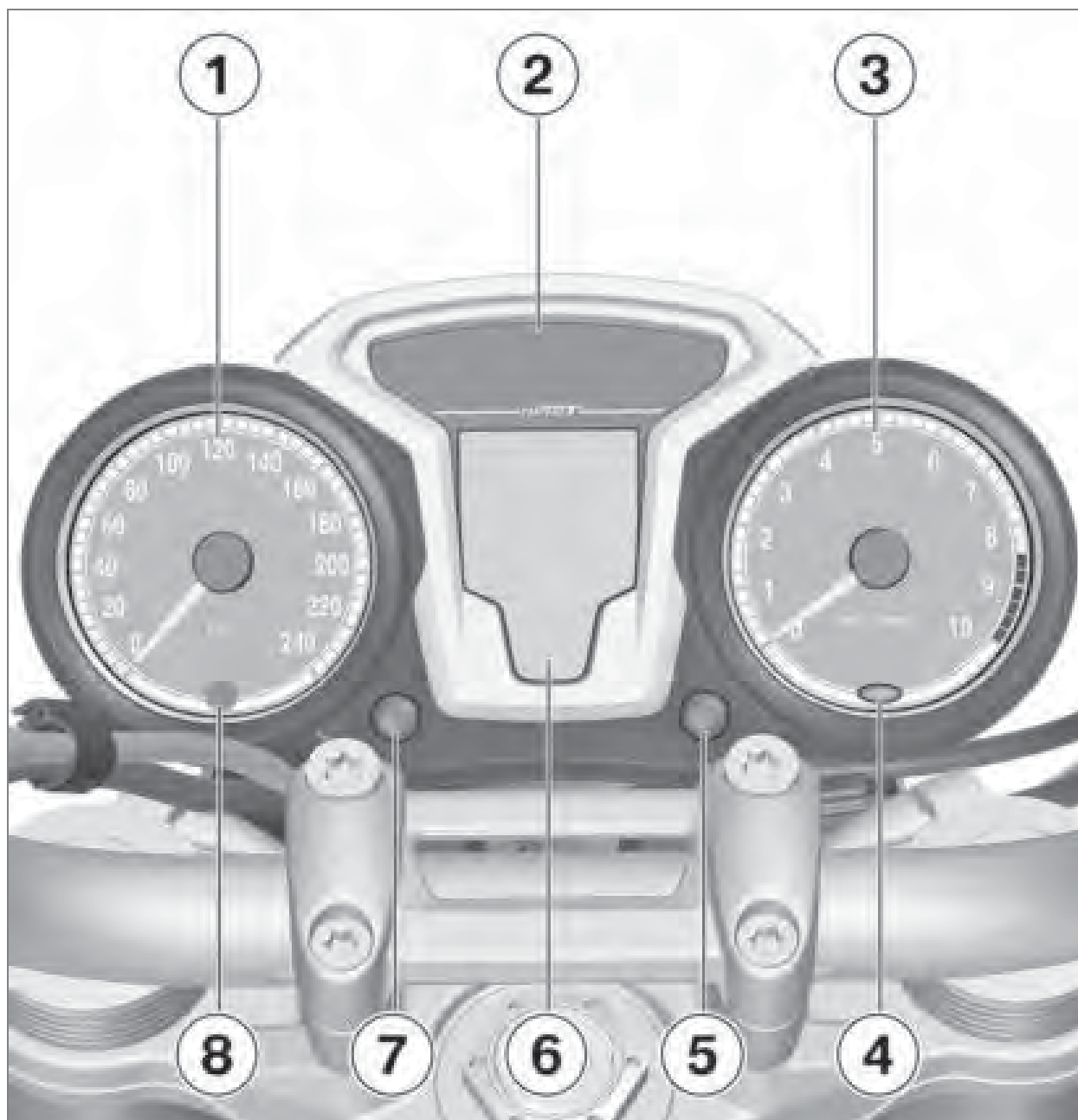

Instrument cluster

- 1** Speedometer
- 2** Warning and indicator lamps (→ 20)
- 3** Tachometer
- 4** Ambient light sensor (for brightness adjustment of instrument lighting)
- 5** Clock (→ 31)
- 6** Multifunction display (→ 21)
- 7** Display (→ 32)
- 8** Indicator lamp
– with anti-theft alarm^{OE}
Anti-theft alarm system (DWA)

Displays

Warning and indicator lamps	20
Multifunction display	21
Meaning of symbols	22
Service display	22
Fuel reserve	22
Warning lamps	23

Warning and indicator lamps

- 1** Turn indicator, left
- 2** Universal warning lamp, appears together with warnings in display panel (➡ 23)
- 3** Neutral position (idling)
- 4** High-beam headlight (➡ 33)
- 5** Turn indicator, right
- 6** ABS (➡ 27)
- 7** Fuel-reserve warning lamp (➡ 25)
- 8** Warning light for battery charge current (➡ 26)

 The ABS symbol can be shown differently depending on the country. ◀



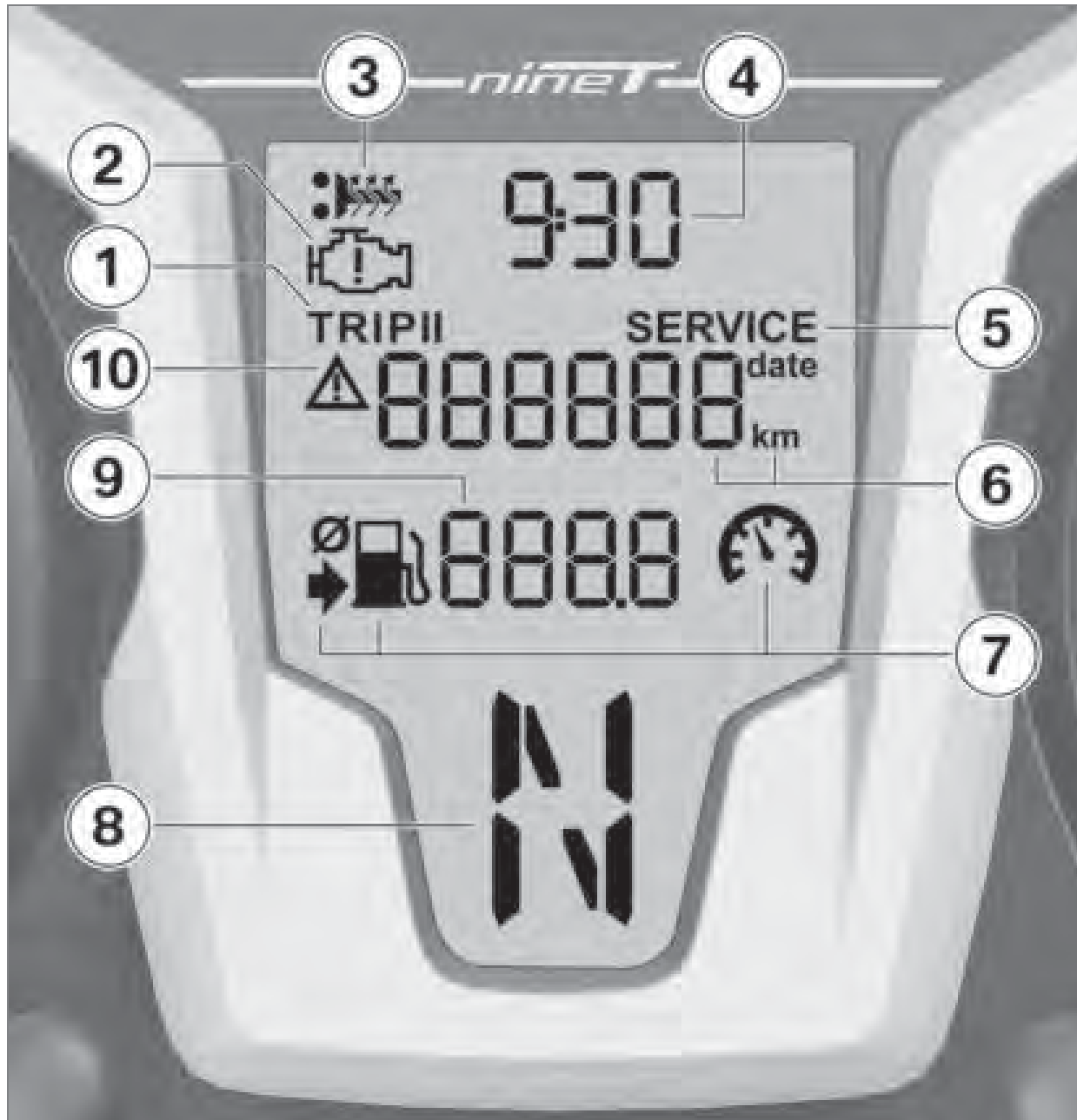



Multifunction display

- 1 Trip odometer (➡ 32)
- 2 Warning lamp for electronic engine management (➡ 25)
- 3 – with heated grips^{OA}
Operating heated grips (➡ 36)
- 4 Clock (➡ 31)
- 5 Service display (➡ 22)
- 6 Odometer
- 7 Indicator lights (➡ 22)
- 8 Gear indicator, "N" is shown for Neutral
- 9 Reading display range
- 10 Warning indicator (➡ 23)

Meaning of symbols

 Average fuel consumption

 Average speed

 Current fuel consumption

Service display



If the time remaining until the next service will elapse within one month, the service date **1**

appears briefly following the pre-ride check.



If the vehicle covers high annual mileages then shorter service intervals may be required. If the mileage for the brought-forward service is within the display range, the remaining mileage **1** then appears briefly following the pre-ride check.

 Indication of maximum remaining mileage until next service:

621 miles (1000 km)

 Indication of maximum remaining mileage until next service:

62 miles (100 km) (Time until service due is counted down in steps.)

Fuel reserve

The fuel level in the fuel tank, when the fuel warning lamp switches on, depends on the driving dynamics. The more the fuel is moved within the tank (due to frequently changing inclined positions, frequent braking and accelerating), the more difficult it is to determine the reserve quantity. For this reason, the reserve quantity cannot be accurately indicated.

 After the fuel warning lamp is switched on, the range already covered (reserve trip) is automatically displayed.

The distance, which can still be driven with the reserve quantity, depends on the driving style (on the consumption) and on the fuel level when the warning lamp was initially activated (see the explanation above).

The odometer for the fuel reserve is reset if the fuel level after refueling is greater than the reserve quantity.

Warning lamps

Display

Warnings are displayed with the corresponding warning lamps.













Warnings for which no separate warning lamp is available, are indicated using the 'General' warning lamp **1** in conjunction with a warning or a warning symbol in the multifunction display. The universal warning lamp shows red or yellow, depending on the urgency of the warning.

If the display in the upper display sector **2** shows a warning, then this is symbolized with the warning triangle **3**. These warnings alternate with the odometers (→ 32).

The universal warning lamp lights up for the most urgent warning.

The possible warnings are listed on the following pages.

Overview of warning indicators

Warning and indicator lamps	Warning symbols in the display panel	Meaning
 Lights up yellow	 + "EWS" is indicated	Electronic immobilizer is active (➡ 25)
 Lights up		Fuel down to reserve (➡ 25)
 Lights up yellow	 Is indicated	Engine in emergency-operation mode (➡ 25)
 Lights up		Battery charge current insufficient (➡ 26)
 Lights up yellow	 + "LAMP" is indicated	Bulb defective (➡ 26)
 Lights up yellow	dWA is indicated	Anti-theft alarm system battery discharged (➡ 26)
 Flashes		ABS self-diagnosis not completed (➡ 27)
 Lights up		ABS error (➡ 27)

Electronic immobilizer is active

 General warning light shows yellow.

 + "EWS" is indicated.

Possible cause:

The key being used is not authorized for starting, or communication between the key and engine electronics is disrupted.

- Remove other motorcycle keys from the ignition key ring.
- Have the defective key replaced, preferably by an authorized BMW Motorrad retailer.

Fuel down to reserve

 Fuel-reserve warning light lights up.

 Fuel shortage can lead to engine misfires. This can result in unexpected engine deactivation (accident hazard) and

damage to the catalytic converter.

Do not drive to the extent that the fuel tank is completely empty.◀

Possible cause:

At the most, the fuel tank still contains the reserve fuel quantity.

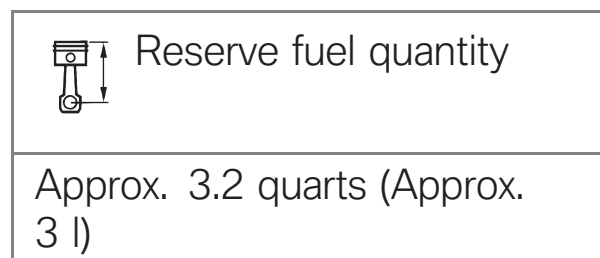

- Refueling procedure (➡ 60).

Engine in emergency-operation mode

 General warning light shows yellow.

 Engine symbol appears on the display.

 The engine is in the emergency operating mode. Un-

usual engine response is a possibility.

Adapt your style of riding accordingly. Avoid accelerating sharply and overtaking.◀

Possible cause:

The engine control unit has diagnosed a fault. In exceptional cases, the engine stops and can no longer be started. Otherwise, the engine runs in the emergency operating mode.

- Continued driving is possible, however the accustomed engine performance may not be available.
- Have the malfunction corrected as soon as possible at an authorized workshop, preferably an authorized BMW Motorrad retailer.

Battery charge current insufficient



Battery warning light lights up.



A discharged battery will lead to the failure of various motorcycle systems such as lighting, engine or ABS. This can result in dangerous driving situations.

Do not continue riding. ◀

Possible cause:

Alternator or alternator belt defective

- Have the malfunction corrected as soon as possible at an authorized workshop, preferably an authorized BMW Motorrad retailer.

Bulb defective



General warning light shows yellow.



+ "LAMP" is indicated.



Failure of a bulb on the motorcycle is a safety risk because it potentially makes the motorcycle less noticeable to other road users.

Replace defective bulbs as soon as possible; it is best always to carry a complete set of spare bulbs on the motorcycle. ◀

Possible cause:

Bulb defective

- Locate defective bulb with visual check.
- Replacing bulbs for dipped and main-beam headlights (➡ 87).
- Replacing bulb for parking light (➡ 88).
- Replacing bulb for front and rear turn indicator (➡ 89).
- Replacing LED tail light (➡ 90).

Anti-theft alarm system battery discharged

– with anti-theft alarm^{OE}



General warning light shows yellow.

The warning dWA is displayed with the warning triangle in front of it.



This fault message is only shown for a short time immediately following the Pre-Ride-Check. ◀

Possible cause:

The anti-theft alarm system battery is completely discharged. Operation of the anti-theft alarm system is no longer ensured when the vehicle's battery is disconnected.

- Contact an authorized specialist service facility, preferably an authorized BMW Motorrad dealer.

ABS self-diagnosis not completed



ABS warning lamp flashes.

Possible cause:

The ABS function is not available, because the self-diagnosis has not been completed. To check the wheel sensors, the motorcycle must be driven a few yards.

- Ride off slowly. It must be noted that the ABS function is not available until the self-diagnosis has been completed.

ABS error



ABS warning lamp lights up.

Possible cause:

The ABS control unit has detected an error. The ABS function is not available.

- Continued driving is possible while taking the failed ABS function into account. Observe additional information on situations which can lead to an ABS error (➡ 65).
- Have the malfunction corrected as soon as possible at an authorized workshop, preferably an authorized BMW Motorrad retailer.

Operation

Steering and ignition lock	30	Tires	39
EWS Electronic immobilizer.....	31	Headlight	39
Clock	31	Rider and passenger seats.....	40
Display.....	32		
Lights.....	33		
Turn indicators.....	33		
Hazard warning flashers.....	34		
Emergency on/off switch (kill switch)	35		
Clutch	35		
Brakes	36		
Heated handlebar grips	36		
Mirrors	37		
Spring preload	38		
Damping	38		

Steering and ignition lock

Keys

You are provided with 2 ignition keys and one key for removing the passenger seat (➡ 41). Should you lose your keys, refer to the information regarding the electronic immobilizer EWS (➡ 31).

A single key fits the steering and ignition lock and the fuel filler cap.

Switch on ignition

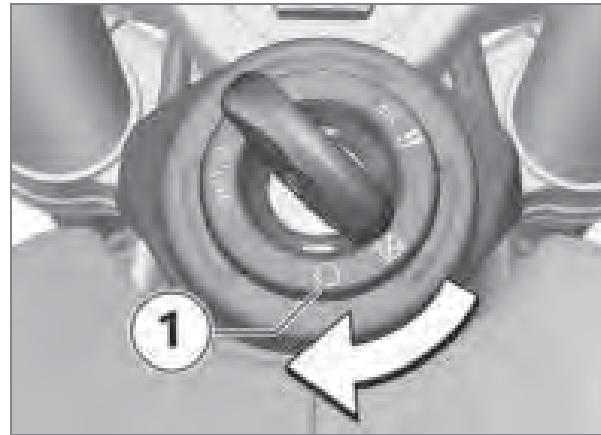

- Turn key to position **1**.
 - » Parking lamps and all function circuits switched on.
 - » Engine can be started.
 - » Pre-Ride Check in progress. (➡ 56)
 - » ABS self-diagnosis in progress. (➡ 57)

Switch off ignition

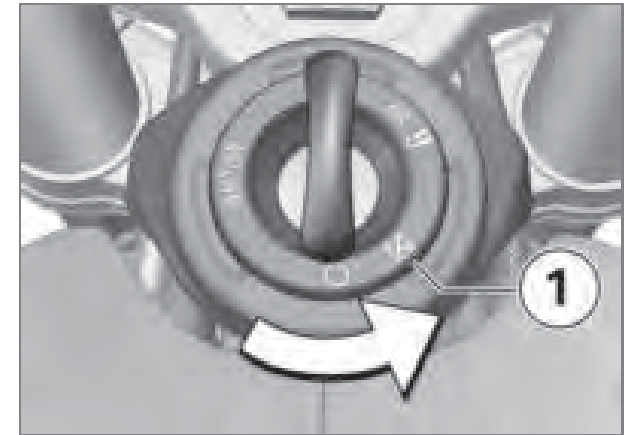

- Turn key to position **1**.
 - » Light switched off.
 - » Handlebars not locked.
 - » Key can now be removed.
 - » Electrically powered accessories remain operational for a limited period of time.
 - » Battery can be recharged via onboard socket.

Locking handlebars

 If the motorcycle is on the side stand, the surface of the ground will determine whether it is better to turn the

handlebars to the left or right. However, the motorcycle is more stable on a level surface with the handlebars turned to the left than with the handlebars turned to the right.

On level ground, always turn the handlebars to the left to set the steering lock. ◀

- Turn handlebars to full left or right lock position.



- Turn key to position **1** while moving handlebars slightly.
 - » Ignition, lights and all electrical circuits switched off.

- » Handlebars locked.
- » Key can now be removed.

EWS Electronic immobilizer

The motorcycle's electronic circuitry monitors the data stored in the ignition key through a ring antenna incorporated in the steering and ignition lock. The engine management system does not enable engine starting until this key has been recognized as "authorized" for your motorcycle.

- ▶ A further key attached to the same ring as the ignition key used to start the engine could "irritate" the electronics, in which case the enabling signal for starting is not issued. The EWS warning is shown in the multifunction display. Always store further vehicle keys separately from the ignition key. ◀

If you lose one of your motorcycle keys, you can have it disabled by your authorized BMW motorcycle retailer.

When having a key disabled you should also bring all of the motorcycle's remaining keys with you. The engine can no longer be started using a disabled key; however, a disabled key can be enabled again.

Ignition keys are only available through an authorized BMW Motorrad retailer. The keys are part of an integrated security system, so the retailer is under an obligation to check the legitimacy of all applications for replacement/extra keys.

Clock

Setting the clock

- ⚠ Attempting to set the clock while riding the motorcycle can lead to accidents.

Adjust the clock only when the motorcycle is stationary.◀

- Switch on ignition (III 30).



- Press and hold button **1** until hours **2** flash.
 - Press button **1** repeatedly until desired hours are shown.
 - Press and hold button **1** until minutes **3** flash.
 - Press button **1** repeatedly until desired minutes are shown.
 - Press and hold button **1** until minutes do not flash anymore.
- » The clock is now set.

Display

Selecting display readings

- Switch on ignition (III 30).



- Press button **1** to select display in upper display sector **2**. The following values can be displayed:
 - Total kilometers (in illustration)
 - Tripmeter 1 (Trip I)
 - Tripmeter 2 (Trip II)
 - Warnings if necessary

Reset tripmeter

- Switch on ignition (III 30).



- Press and hold button **1** until trip odometer has been reset.

Reset average data

- Switch on ignition (III 30).

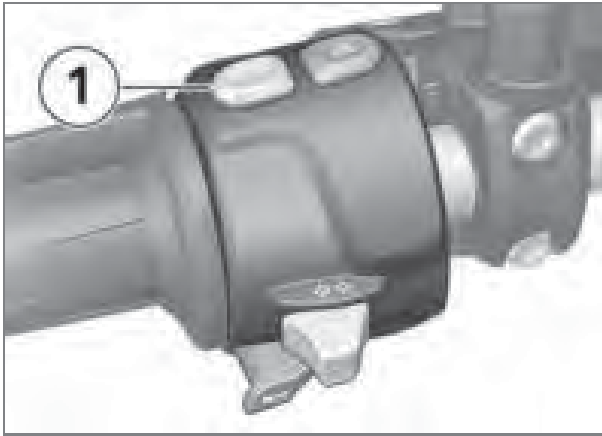

- Press and hold button **1** until displayed value has been reset.

Lights

Parking lights and low-beam headlight

The parking lamps come on automatically when the ignition is switched on.

- ▶ The parking lights are a strain on the battery. Do not leave the ignition switched on longer than absolutely necessary.◀

The headlights automatically come on in their low-beam mode as soon as you start the engine.

- ▶ With the engine switched off, you can switch on the lights by switching on the high-beam headlight with the ignition switched on or by operating the headlight flasher.◀

High-beam headlight and headlight flasher

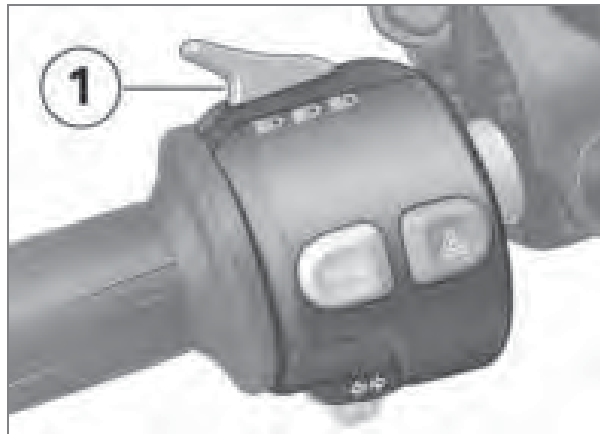

- Press switch **1** toward front to switch on high-beam headlight.
- Pull switch **1** toward rear to actuate headlight flasher.

Parking light

- Switch off ignition (III → 30).

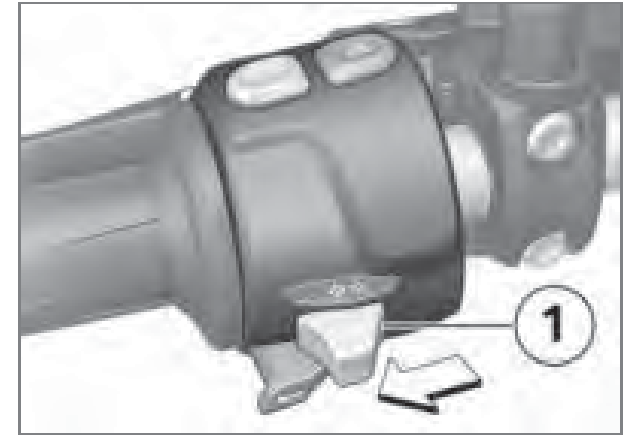

- Immediately after switching off the ignition, press button **1** to left and hold until the parking lights switch on.
- Switch ignition on and then off again to switch off parking light.

Turn indicators

Operate turn indicator

- Switch on ignition (III → 30).

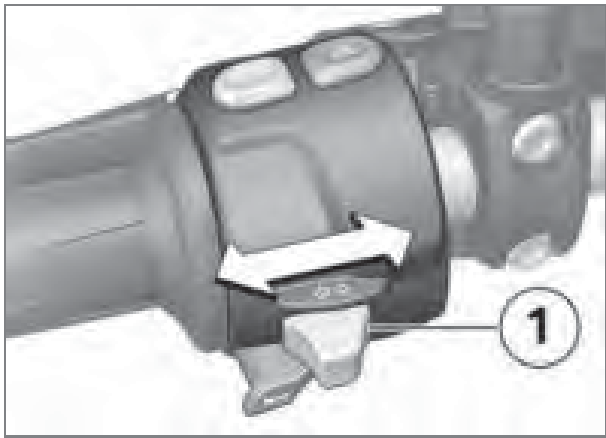

- Press button **1** toward left to switch on left-hand turn indicator.
- Press button **1** toward right to switch on right-hand turn indicator.
- Press button **1** into center position to switch off turn indicators.

 Turn indicator cancellation

The turn indicators automatically switch off when the defined driving time and distance have been reached.

 Turn indicator cancellation

min 10 s

min 984.3 ft (min 300 m)

Hazard warning flashers

Operating hazard warning flashers

 The hazard warning flashers place a strain on the battery. Do not use the hazard warning flashers for longer than absolutely necessary.◀

 If a turn indicator button is pressed with the ignition switched on, the flashing function replaces the emergency flashing function as long as the button is pressed. If the turn indicator button is released, the emergency flasher function becomes active again.◀

- Switch on ignition ( 30).

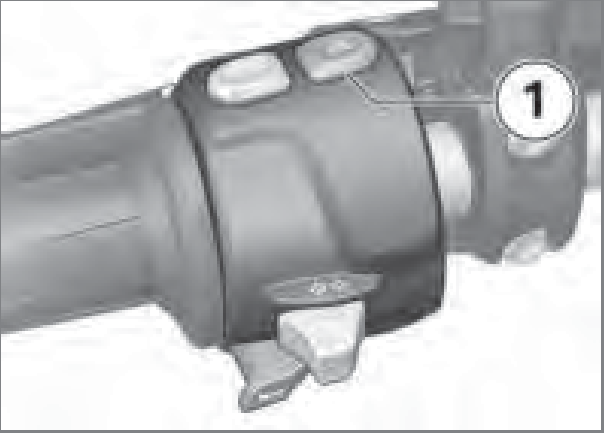

- Press button **1** to switch on hazard warning flashers.
- » Ignition can be switched off.
- Press button **1** again to switch off hazard warning flashers.

Emergency on/off switch (kill switch)



- 1** Emergency on/off switch (kill switch)

 Operating the emergency ON/OFF switch when riding can cause the rear wheel to lock and thus cause a fall. Do not operate the emergency ON/OFF switch when riding.◀

The engine can be switched off easily and quickly using the emergency on/off switch.

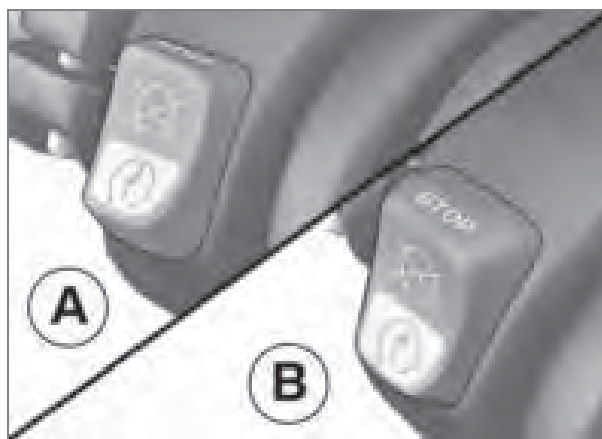



- A** Engine switched off
B Operating position

 The engine can only be started in the operating position.◀

Clutch

Adjusting clutch lever

 If the position of the clutch fluid reservoir is changed, air can enter the clutch system. Do not reposition the handlebar controls on the handlebars or the handlebars in their mounts.◀

 Adjusting the clutch lever while driving can lead to accidents.

Only adjust the clutch lever when the motorcycle is stationary.◀

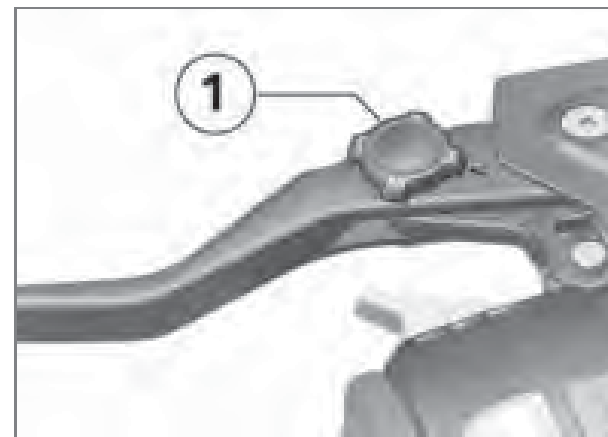

- Turn adjusting screw **1** into desired position.

 The adjusting screw can be turned more easily if you press the clutch lever forward when doing so.◀

- » 4 settings are possible:
 - **Position 1:** shortest distance between handlebar grip and clutch lever.

- **Position 4:** greatest distance between handlebar grip and clutch lever.

Brakes

Adjusting handbrake lever

 Changing the position of the brake-fluid reservoir can allow air to penetrate the brake system.

Do not reposition the handlebar controls on the handlebars or the handlebars in their mounts.◀

 Adjusting the handbrake lever while driving can lead to accidents.

Only adjust the handbrake lever when the motorcycle is stationary.◀

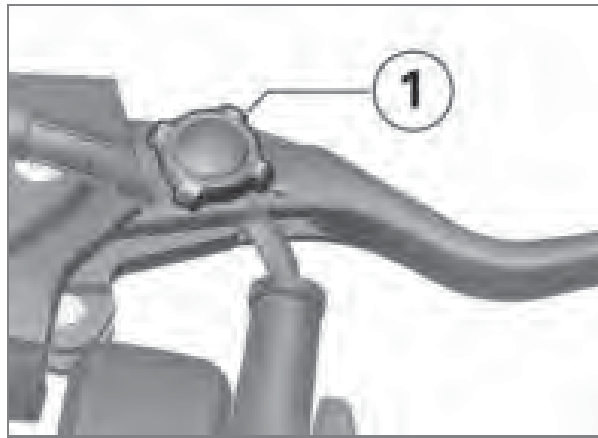

- Turn adjusting screw **1** into desired position.

 The adjusting screw can be turned more easily if you press the handbrake lever forward when doing so.◀

» 4 settings are possible:

- **Position 1:** shortest distance between handlebar grip and brake lever.
- **Position 4:** greatest distance between handlebar grip and brake lever.

Heated handlebar grips

- with heated grips^{OA}

Operating heated grips

 The heated grips option can only be activated when the engine is running.◀

 The increase in power consumption caused by the heated grips can drain the battery if you are riding at low engine speeds. If the battery is inadequately charged, the heated grips are switched off to ensure starting capability.◀

- Starting the engine (▶▶▶ 56).

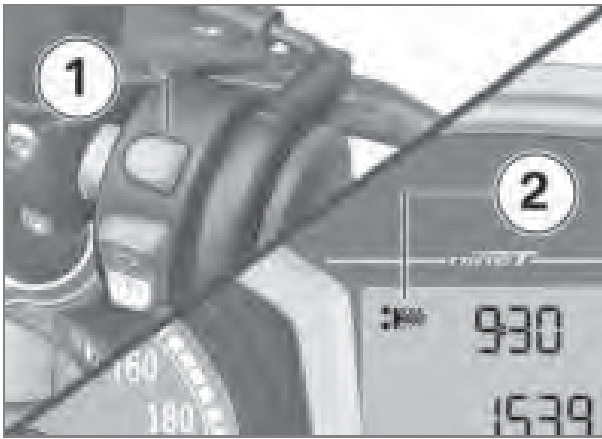

- Press button **1** repeatedly until desired heating level **2** is shown.

The handlebar grips can be heated at two different levels.



50 % heating output



100 % heating output

- » The 2nd heating level is used for fast heat-up of the grips; then the switch should be switched back to the 1st level.

- » If no further changes are made the selected heating level is adopted as the setting.
- To switch off heated grips, press button **1** until heated grip symbol **2** is no longer shown in the display.

Mirrors

Adjust mirrors



- Move mirror into desired position by twisting.

Adjust mirror arm

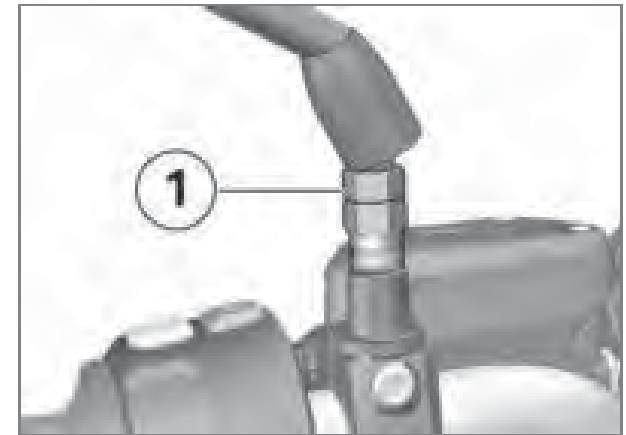

- Slide up protective cap over threaded fastener on mirror arm.
- Loosen nut **1** with tool from onboard tool kit.
- Turn mirror arm into desired position.
- Tighten the nut **1** while holding the mirror arm in place.



Mirror (locknut) on adapter

16 lb/ft (22 Nm)

- Slide protective cap over threaded fastener.

Spring preload Setting

It is essential to set the spring preload to suit the load carried by the motorcycle. Increase spring preload when the vehicle is heavily loaded and reduce spring preload accordingly when the vehicle is lightly loaded.

Adjust spring preload at rear wheel

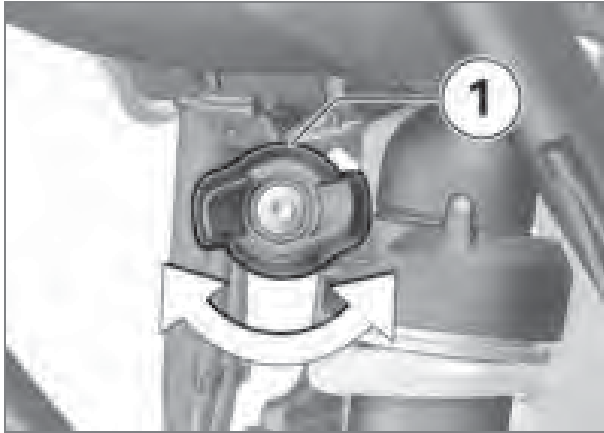

- Make sure ground is level and firm and park motorcycle.

 Your motorcycle's handling will suffer if you do not match the spring-preload and damping-characteristic settings. Adjust damping characteristic to changed spring preload.◀

- To increase spring preload, turn adjustment wheel **1** clockwise.
- To decrease spring preload, turn adjustment wheel **1** counterclockwise.

 A recommendation on the chassis calibration is provided in the chapter “Technical Data - Suspension”.◀

Damping Setting

Damping must be adjusted to the road conditions and the spring preload.

- A rough road surface requires softer damping than a smooth road surface.
- An increase in spring preload requires firmer damping, a reduction in spring preload requires softer damping.

Adjusting damping on rear wheel

- Make sure ground is level and firm and park motorcycle.



 When adjusting the damping, contact with the hot muffler is possible. Allow the muffler to cool down.◀

 There is a danger of burns from heated-up/hot components.

Wear protective gloves when handling warm parts. ◀

- Adjust damping with the toolkit using the adjusting screw **1**.

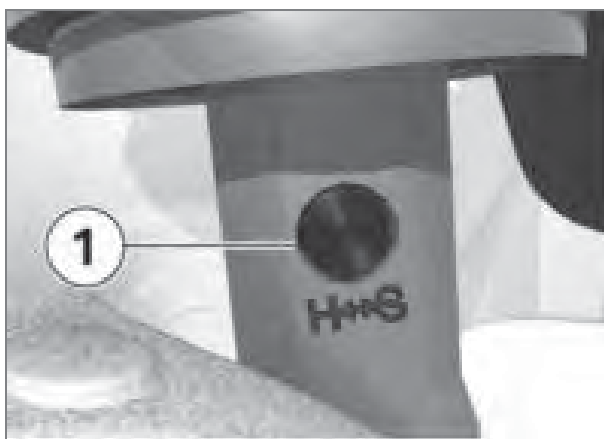

- To increase damping, turn adjusting screw **1** clockwise.
- To decrease damping, turn adjusting screw **1** counterclockwise.

 A recommendation on the chassis calibration is pro-

vided in the chapter “Technical Data - Suspension”. ◀

Tires

Check tire pressure

 Incorrect tire inflation pressure results in poorer handling characteristics of the motorcycle and reduces the life of the tires.

Ensure proper tire inflation pressure. ◀

 At high road speeds, vertically installed tire valves have a tendency to open on their own.

To avoid a sudden loss of tire inflation pressure, use valve caps with a rubber sealing ring for valves installed vertically to the wheel rim and tighten firmly. ◀

- Make sure ground is level and firm and park motorcycle.

- Check tire pressures against data below.

 Tire pressure, front

36.3 psi (2.5 bar) (with tire cold)

 Tire pressure, rear

36.3 psi (2.5 bar) (One-up, with cold tires)

42.1 psi (2.9 bar) (Operation with passenger, with cold tires)

If the tire pressure is incorrect:

- Correct tire pressure.

Headlight

Adjusting headlight for RHD/LHD traffic

This motorcycle's headlight features a symmetrical low beam. No special adjustments or procedures are required prior to oper-

ating the motorcycle in a country where traffic travels on the side of the road opposite to that of your home country (left-hand drive to right-hand drive or vice versa).

Headlamp range and spring preload

The headlamp range generally remains constant due to the adjustment of the spring preload to the loading state.

However, in the case of very high payloads, the available spring preload adjustment might not be adequate. In this case, the headlamp range must be adjusted to the weight.

 If there are questions whether the headlight range is correct, consult a specialized workshop, preferably an authorized BMW Motorrad retailer. ◀

Rider and passenger seats

Removing rider's seat

- Remove passenger seat (➡ 41).

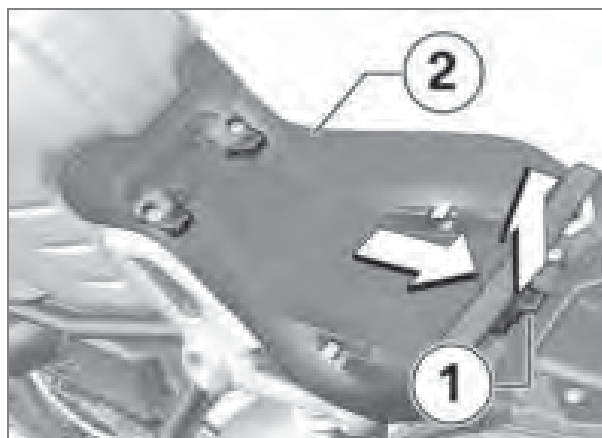

- Pull up latch **1**.
- Pull rider's seat **2** to rear and remove.

Installing driver's seat

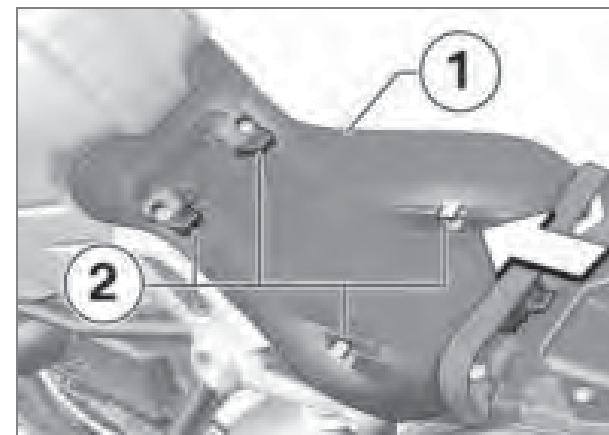

- Insert driver's seat **1** into lugs **arrows**.
- Press down on rear of rider's seat **1**.
- » Rider's seat clicks audibly into place.
- Install the passenger seat (➡ 41).

Removing passenger seat

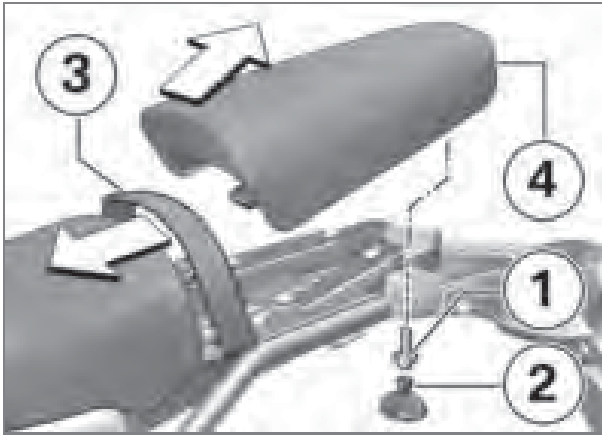

- Remove screw **1** with seat key **2**.
- Pull grab strap **3** toward rider's seat and work passenger seat **4** to rear to remove.

Install the passenger seat

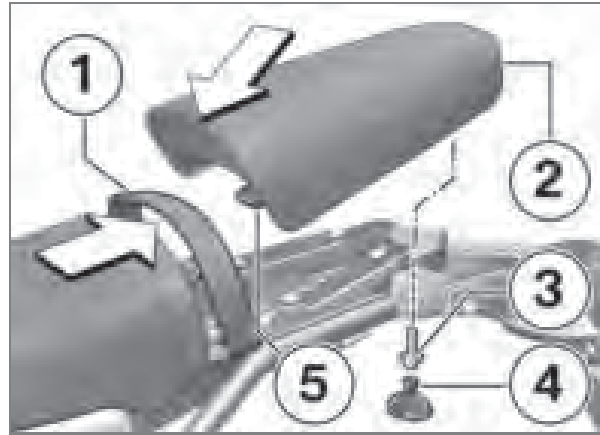

- Mount passenger seat **2** in rear frame while making sure that lug **5** of passenger seat is seated in rear frame.
- Tighten the screw **3** hand-tight with the seat key **4**.
- Pull grab strap **1** over passenger seat.

Anti-theft alarm system DWA

Overview	44
Activation	44
Alarm function	46
Deactivation	47
Programming	48
Logging on remote control.....	49
Synchronizing.....	50
Battery.....	51

Overview

– with anti-theft alarm^{OE}

General information on DWA

Any attempt to move the motorcycle, change its position, start it without authorization or disconnect the motorcycle battery, results in the alarm being triggered. The sensitivity of the system is designed so that minor vibrations of the motorcycle do not trigger an alarm. Each theft attempt is signaled following activation of the system acoustically with the siren and optically with synchronized flashing of all 4 turn indicators.

You can adjust the behavior of your DWA in partial areas to meet your needs.

Protection of motorcycle battery

To protect the motorcycle battery and to maintain the starting capability, the activated DWA switches off automatically after several days. However, it remains active for at least 10 days.

Radio interference

Radio systems or devices which transmit on the same frequency as the remote control of the DWA can interfere with its function. With corresponding problems point the remote control at the vehicle from a different direction.

Controls



- 1** LED (➡ 17)
- 2** Right-hand button (➡ 46)
- 3** Left-hand button (ribbed) (➡ 45)

Activation

– with anti-theft alarm^{OE}

Activation with motion sensor



The alarm function will be activated

- by pressing the button **1** of the remote control once or
- by switching off the ignition (if programmed); after the ignition is switched off, 30 seconds pass until the activation phase

Activation is confirmed

- by the turn indicators lighting up twice and
- with a double alarm tone.

If the alarm function is to be activated after the ignition has been switched off for more than one minute, then the button **1** must be pressed for longer than one second. After approx. one hour in the disarmed state, the DWA switches off to protect the battery. To activate the alarm function after this period, the ignition must be switched on and then off again.

Activation phase

The anti-theft alarm system requires 15 seconds until it is completely activated. No alarm triggering takes place during this time.

Protection of the battery



If the alarm function is to be activated after the ignition has been switched off for more than one minute, then the button **1** must be pressed for longer than one second. After approx. one hour in the deactivated state, the DWA switches off to protect the battery. To activate the alarm function after this period, the ignition must be switched on and then off again.

Motion sensor when transporting the motorcycle

If, for example, the motorcycle is to be transported by train, it is advisable to switch off the motion sensor. The strong movements could result in an accidental triggering of the alarm.

Deactivating motion sensor



- Press button **1** of the remote control again during the activation phase.

- » Turn indicators are illuminated three times.
- » Alarm tone sounds three times.
- » Motion sensor is deactivated.

Alarm function

- with anti-theft alarm^{OE}

Alarm triggering

The alarm can be set off by:

- The motion sensor
- Switching on the ignition with an unauthorized key
- Disconnection of the DWA from the vehicle battery (DWA battery assumes the power supply).

Alarm



The duration of the alarm is 26 seconds. The system is reactivated after another 12 seconds. A triggered alarm can be interrupted by pressing the button **1** of the remote control. This function does not change the state of the anti-theft alarm system.

During the alarm, an alarm tone sounds and the turn indicators flash. The type of alarm sound can be programmed.

Reason for triggering of the alarm

After the alarm function has been deactivated, the DWA indicator lamp signals the reason for any alarm triggering which may have occurred for one minute:

- 1x flash: motion sensor; motorcycle was tilted forward/back
- 2 flashes: motion sensor; motorcycle was tilted to the side
- 3 flashes: ignition switched on with unauthorized key
- 4 flashes: DWA disconnected from motorcycle battery

Note on alarm triggering

If an alarm was triggered after the last activation of the alarm function, then this is pointed out with a single signal tone after the ignition is switched on.

Deactivation

- with anti-theft alarm^{OE}

Deactivating alarm function



- Press button **1** of remote control once **or** switch on ignition with an authorized key.

▶ The alarm function can only be deactivated with the ignition key if the emergency ON/OFF switch is in the operating position.◀

▶ If the alarm function is deactivated by means of the remote control and the ignition then not switched on, the alarm function is automatically reactivated after 30 seconds if "Activation after ignition off" has been programmed.◀

- » Turn indicators light up once.
- » Alarm tone sounds once (if programmed).
- » Alarm function is deactivated.

Protection of the battery

After approx. one hour in the activated state, the receiver for the remote control in the DWA switches off to protect the battery. The ignition must be switched on to deactivate the alarm function after this period.

Programming

- with anti-theft alarm^{OE}

Programming options

The anti-theft alarm system can be adapted to individual needs in the following points:

- Confirmation alarm tone after activation/deactivation of the DWA in addition to the turn indicators lighting up
- Rising and falling or intermittent alarm tone
- Automatic activation of the alarm function when the ignition is switched off

Factory settings

The anti-theft alarm system is delivered with the following factory settings:

- Confirmation alarm tone after activation/deactivation of the DWA: no
- Alarm tone: intermittent

- Automatic activation of the alarm function when the ignition is switched off: no

Programming DWA



- Deactivate alarm function.
- Switch on ignition.
- Press button **1** three times.
 - » Acknowledgment tone sounds once.
- Switch off the ignition within ten seconds.
- Press button **2** three times.
 - » Acknowledgment tone sounds once.

- Switch on the ignition within ten seconds.
 - » Acknowledgment tone sounds three times.
 - » The programming function is active.

The actual programming is carried out in 4 steps, and Step 2 is not assigned any function. The number of flashing signals on the **DWA** indicator lamp of the motorcycle shows the active programming step. Pressing the button **1** is confirmed by an alarm tone, and pressing the button **2** by an acknowledgment tone.

- **Step 1:** is a confirmation tone to sound after the DWA is activated/deactivated?

Yes:

- Press button **1**.

No:

- Press button **2**.

- **Step 2:**

This step is not assigned any function.

- Press button **1** or button **2**.

- **Step 3:** Which alarm tone is to be selected?

Rising and falling:

- Press button **1**.

Intermittent:

- Press button **2**.

- **Step 4:** Is the alarm function to be automatically activated after the ignition is switched off?

Yes:

- Press button **1**.

No:

- Press button **2**.

When is the programming canceled?

Programming is canceled

- by switching off the ignition before the last programming step.
- **or** automatically if more than 30 seconds pass between 2 programming steps.

The data are not saved when programming is canceled.

Save programming

Programming is saved

- by switching off the ignition after the last programming step.
- **or** automatically 30 seconds after the last programming step.

The DWA indicator lamp stops flashing and 4 acknowledgment tones sound.

Logging on remote control

- with anti-theft alarm^{OE}

When is it necessary to log on a remote control?

Should you log on an additional remote control or want to replace a lost remote control, then you must always log on all remote controls with the DWA. You can log on a maximum of 4 remote controls.

Logging on remote control



- Deactivate alarm function.
- Switch on ignition.
- Press button **2** three times.
- » Acknowledgment tone sounds once.
- Switch off ignition within ten seconds.
- Press button **2** three times.
- » Acknowledgment tone sounds once.
- Switch on ignition within ten seconds.

» Acknowledgment tone sounds twice.

You can log on a maximum of 4 remote controls for the DWA. The logon for each remote control is carried out in three steps.

- Press and hold button **1** and button **2**.
- » LED flashes for ten seconds.
- As soon as the LED goes out, release button **1** and button **2**.
- » LED lights up.
- Press button **1** or button **2**.
- » Alarm tone sounds once.
- » LED goes out.
- » Remote control is logged on.
- Repeat the three previous work steps for each additional remote control.

Logon ended

The logon is ended if

- 4 remote controls have been logged on
- the ignition is switched off

- no button was pressed for 30 seconds after the ignition was switched off
- no button was pressed for 30 seconds after a remote control was logged on

After the logon is completed, the LED flashes and the acknowledgment tone sounds three times.

Synchronizing

- with anti-theft alarm^{OE}

When is it necessary to synchronize the remote control?

The remote control must be synchronized when the buttons of the remote control has been operated more than 256x outside the range of the receiver. In this case, the receiver on the motorcycle no longer reacts to the signals of the remote control.

Synchronizing remote control



- Press and hold button **1** and button **2**.
 - » LED flashes for ten seconds.
- As soon as the LED goes out, release button **1** and button **2**.
 - » LED lights up.
- Press button **1** or button **2**.
 - » LED goes out.
- Remote control is synchronized.

Battery

– with anti-theft alarm^{OE}

When is a battery change required?

The batteries of the remote control must be replaced after approx. 2 - 3 years. A weak battery can be recognized from the fact that the LED does not light up at all or only briefly when a button is pressed.

Replacing battery

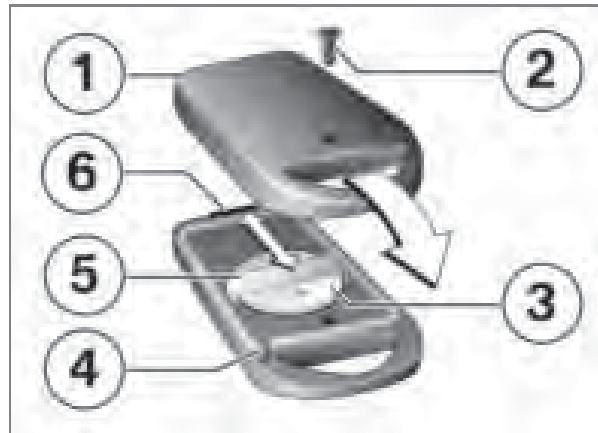

- Remove screw **2** and take off lower housing section **1**.

- Slide old battery **5** forward under retainer **3**.

 Batteries of the wrong type or incorrect poling of the batteries can destroy the device. Use specified battery (see the chapter "Technical Data"). Ensure proper poling when inserting the battery. ◀

- Install a new battery while making sure that the positive terminal of the battery is at the top.
- Position lower housing section on nose **6** of front edge and close while watching two guide pins **4**.
- Install screw **2**.
 - » The LED of the remote control lights up; i.e. the remote control must be synchronized.



- To synchronize the remote control within the range of the receiver, press the button **1** twice.
 - » LED **2** begins to flash and goes out after a few seconds.
 - » The remote control is ready to operate again.

Riding

Safety instructions	54
Checklist.....	55
Starting	56
Breaking in.....	57
Brakes	58
Parking your motorcycle	59
Refueling	60
Fastening motorcycle for transport	61

Safety instructions

Rider's Equipment

The following clothing protects you while riding:

- Helmet
- Rider's suit
- Gloves
- Boots

This applies even to short journeys, and to every season of the year. Your authorized BMW Motorrad retailer will be happy to advise you and has the correct clothing for every purpose.

Correct loading



Overloading and imbalanced loads can adversely affect the motorcycle's handling. Do not exceed the gross weight limit and observe the loading information. ◀

- Adjust spring preload, suspension damping rate settings and tire inflation pressures for the current gross vehicle weight.
- Pack heavy pieces of luggage and cargo as low and as close to the center of the motorcycle as possible.
- with tank rucksack^{OA}
- Observe maximum payload of tank rucksack.



Payload of tank rucksack

≤11 lbs (≤5 kg)◀

- with rear bag^{OA}
- Observe maximum payload of the rear bag.



Payload of rear bag

max 11 lbs (max 5 kg)◀

Speed

If you ride at high speed, always bear in mind that various boundary conditions can adversely affect the handling of your motorcycle, e.g.:

- Incorrect settings of spring-strut and shock absorber system
- Imbalanced load
- Loose clothing
- Insufficient tire inflation pressure
- Poor tire tread
- Attached luggage systems, such as a tank rucksack or rear bag. Observe the maximum permissible speed indicated on the label in the respective luggage system.

Risk of poisoning

Exhaust fumes contain carbon monoxide, which is colorless and odorless but highly toxic.

 Inhaling exhaust fumes therefore represents a health hazard and can even cause loss of consciousness with fatal consequences.

Do not inhale exhaust fumes.
Do not run the engine in closed rooms.◀

Burn hazard

 Engine and exhaust system become very hot when the vehicle is in use. There is a risk of burn injuries by contact with hot surfaces.

After parking the motorcycle, make sure that nobody comes into contact with the engine and exhaust system.◀

Catalytic converter

If misfiring causes unburned fuel to enter the catalytic converter, there is a danger of overheating and damage.

The following must be observed:

- Do not run the fuel tank dry
- Do not run the engine with the spark-plug cap removed
- Stop the engine immediately if it misfires
- Use unleaded fuel only
- Comply with all specified maintenance intervals.

 Unburned fuel will destroy the catalytic converter.

Note the points listed for protection of the catalytic converter.◀

Danger of overheating

 Cooling would be inadequate if the engine were allowed to idle for a lengthy period with the motorcycle at a standstill: overheating would result. In

extreme cases, the motorcycle could catch fire.

Do not allow the engine to idle unnecessarily. After starting, ride off immediately.◀

Modifications

 Modifications of the motorcycle (e.g. engine management system, throttle valves, clutch) can cause damage to the affected components and failure of safety-related functions. Damage caused in this way is not covered by the warranty.

Do not make any modifications.◀

Checklist

Use the following checklist to check important functions, settings and wear limits before you ride off.

Before every journey:

- Brakes
- Front and rear brake fluid levels
- Clutch function
- Damping setting and spring preload
- Tread depth and tire inflation pressure
- Secure hold of the tank rucksack or the rear bag.

At regular intervals:

- Engine oil level (every time you refuel)
- Brake pad wear (at every 3rd refueling stop).

Starting**Starting the engine**

- Switch on ignition (➡ 30).
- » Pre-Ride Check in progress. (➡ 56)
- » ABS self-diagnosis in progress. (➡ 57)

- Engage neutral, or pull back clutch lever if a gear is engaged.

▶ You cannot start the motorcycle with the side stand extended and a gear engaged. The engine will switch itself off if it is started with the transmission in neutral and then a gear is engaged before retracting the side stand.◀

- During cold start and at low temperatures:
 - » Pull clutch.



- Press starter button **1**.

▶ The start attempt is automatically interrupted if battery voltage is too low. Recharge the battery before you start the engine, or use jump leads and a donor battery to start. More detailed information can be found in the section Servicing under the heading Jump-starting.◀

- » Engine starts.
- » Consult the troubleshooting chart if the engine refuses to start. (➡ 110)

Pre-Ride Check

After the ignition is switched on, the instrument cluster conducts a test of the pointer instruments and the warning and indicator lamps, i.e. the so-called "Pre-Ride-Check". This test routine stops if the engine is started before it is completed.

Phase 1

The pointer of the tachometer and speedometer move to the end stop. At the same time, all warning and indicator lamps are switched on consecutively.

Phase 2

» The general warning lamp changes from yellow to red.

Phase 3

The pointer of the tachometer and speedometer move to their starting position. At the same time all of the activated warning and indicator lamps are switched off in reverse sequence.

If a needle failed to move, or if one of the warning or indicator lamps failed to light up:

- Have the malfunction corrected as soon as possible at an authorized workshop, preferably an authorized BMW Motorrad retailer.

ABS self-diagnosis

The self-diagnosis routine is determining whether BMW Motorrad ABS is ready for operation. The self-diagnosis routine runs automatically when you switch on the ignition. To check the wheel speed sensors, the motorcycle must be driven a few yards.

Phase 1

» Check on system components monitored by the diagnostic system while vehicle is parked.



ABS warning lamp flashes.

Phase 2

» Check wheel sensors while starting off.



ABS warning lamp flashes.

ABS self-diagnosis completed

ABS warning lamp goes out.

- Watch all warning and indicator lamps on the display. An ABS error is indicated following completion of the ABS self-diagnosis routine.
- It remains possible to continue riding. It must be noted that the ABS function is not available.
- Have the malfunction corrected as soon as possible at an authorized workshop, preferably an authorized BMW Motorrad retailer.

Breaking in Engine

- While running in the motorcycle, vary the throttle opening and engine-speed range fre-

quently; avoid driving for long periods at a constant speed.

- Choose curvy, slightly hilly sections of road if possible.
- Observe the engine run-in speeds.



Engine break-in speeds

<5500 min⁻¹ (Odometer reading 0...124 miles (0...200 km))

<6500 min⁻¹ (Odometer reading 124...249 miles (200...400 km))

<7500 min⁻¹ (Odometer reading 249...373 miles (400...600 km))

Briefly maximum engine speed (Odometer reading 373...559 miles (600...900 km))

- Observe mileage, after which the running-in check should be performed.



Mileage until first running-in check

311...746 miles
(500...1200 km)

Brake pads

New brake pads must be run in before they achieve their optimum friction force. This initial reduction in braking efficiency can be compensated for by exerting greater pressure on the brake levers.



New brake pads can extend stopping distance by a significant margin.

Brake early. ◀

Tires

New tires have a smooth surface. This must be roughened by riding in a restrained manner at various heel angles until the tires are run in. This running in proce-

dures is essential if the tires are to achieve maximum grip.



New tires do not provide full tire traction. Accident hazards exist in particular on wet roads and at extreme angles. Always think well ahead and avoid extreme angles. ◀

Brakes

How do you achieve the shortest stopping distances?

The dynamic load distribution between the front and rear wheel changes during braking. The heavier you brake, the greater the weight transfer to the front wheel. Increases in the load at an individual wheel are accompanied by a rise in the effective braking force that the wheel can provide.

To achieve the shortest possible braking distance, the front

brake must be applied quickly and with increasing force. This procedure provides ideal exploitation of the extra weight transfer to the front wheel. The clutch should also be disengaged at the same time. The frequently-practiced procedure for "panic braking", in which maximum braking force is applied as rapidly as possible, produces deceleration rates that rise more quickly than the dynamic weight transfer occurs. As a result, a complete transfer of braking force to road surface is not possible.

Locking up of the front wheel is prevented by BMW Motorrad ABS.

Descending mountain passes

 There is a danger of the brakes fading if you use only the rear brakes when descending mountain passes.

Under extreme conditions, the brakes could overheat and suffer severe damage.

Use both front and rear brakes, and make use of the engine's braking effect as well.◀

Wet, soiled brakes

Moisture and dirt on the brake disks and the brake pads result in a decrease in the braking action. Delayed or poorer braking action must be expected in the following situations:

- When driving in the rain and through puddles.
- After washing the motorcycle.
- When driving on roads spread with salt.
- After working on the brakes due to oil or grease residues.
- When driving on soiled roads or offroad.

 Poor braking action due to moisture and dirt.

Brake until brakes are dry or clean; clean if necessary.

Brake early until the full braking action is available again.◀

Parking your motorcycle

Side stand

- Switch off engine.

 If the ground is soft or uneven, there is no guarantee that the motorcycle will rest firmly on the stand.

Always check that the ground under the stand is level and firm.◀

 The side stand is designed to support only the weight of the motorcycle.

Do not lean or sit on the motorcycle with the side stand extended.◀

- Fold out side stand and park motorcycle.
- If the slope of the road permits, turn the handlebars to the left.
- On slopes point the motorcycle uphill and engage 1st gear.

Refueling

Fuel specifications

For optimal fuel economy, the gasoline should be sulfur-free or very low in sulfur content.

 Leaded fuel will destroy the catalytic converter. Do not refuel with leaded gasoline or gasoline with metallic additives, e. g. manganese or Iron.◀

 Ethanol E85 might damage the engine and fuel supply system. Do not refuel with E85, i.e. fuel with an ethanol content of 85 %, or with Flex Fuel.◀

- Fuels with a maximum ethanol content of 10 %, meaning "E10," may be used for refueling. Ethanol should satisfy the quality standards for US (ASTM 4806-xx) and Canada (CGSB-3.511-xx). "xx" - comply with the current standard in each case.

	Recommended fuel quality
	Super Plus unleaded (max. 10 % ethanol, E10) 91 AKI (98 ROZ/RON) 91 AKI

	Alternative fuel quality
	Super unleaded (minor power restriction and possibly higher consumption) (max. 10 % ethanol, E10) 89 AKI (95 ROZ/RON) 89 AKI

Refueling procedure

 Fuel is highly flammable. Fire at the fuel tank can result in fire and explosion. Do not smoke. Never bring a naked flame near the fuel tank.◀

 Fuel expands when exposed to heat. When the tank is overfilled, fuel can escape and get onto the road. This results in a danger of falling. Do not overfill the fuel tank.◀

 Fuel attacks plastic surfaces, making them cloudy or unattractive. Immediately wipe off plastic parts after contact with fuel.◀

- Make sure ground is level and firm and park motorcycle.

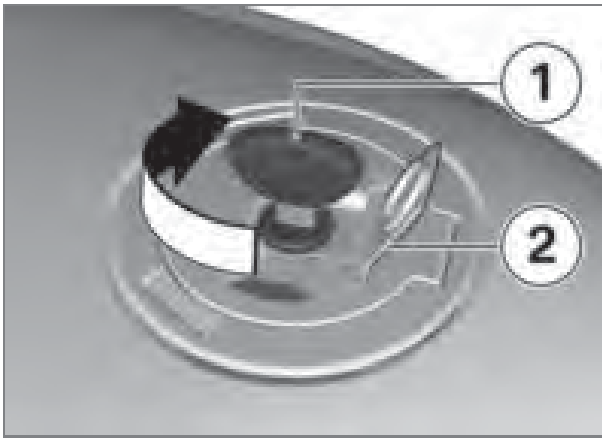

- Open protective cap **2**.
- Unlock cap of fuel tank **1** with ignition key by turning it clockwise and fold it up.

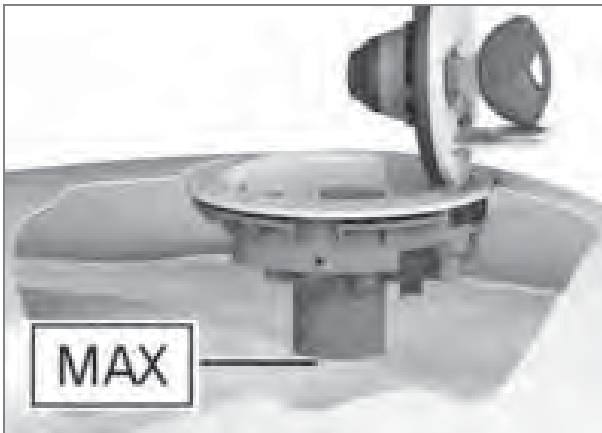

- Refuel with a fuel meeting the specifications below, continu-

ing until fuel is no higher than lower edge of filler neck.

▶ When refueling after running on reserve, make sure that you top up the tank to a level above reserve, as otherwise the sensor will not be able to register the new level and the fuel warning lamp will not be switched off.◀

▶ The "usable fuel quantity" indicated in the Technical data is the fuel quantity, which can be refueled, if the fuel tank was completely emptied, i.e., if the engine dies off due to lack of fuel.◀

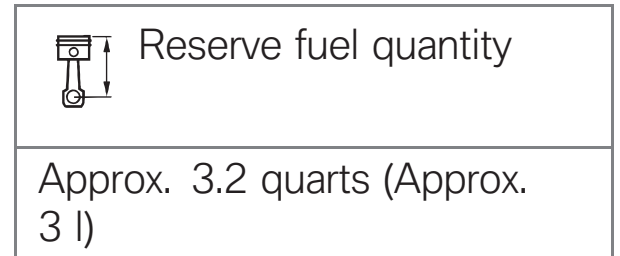
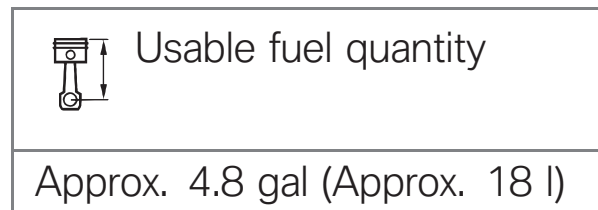

- Press fuel tank cap down firmly to close.
- Remove key and close protective cap.

Fastening motorcycle for transport

- Protect all component surfaces against which straps are routed against scratching. For example, use adhesive tape or soft cloths.



! The motorcycle can tip away to the side and fall over.

Secure motorcycle against tipping away to the side, preferably with the help of a second person.◀

- Push motorcycle onto transport surface, and do not place on side stand.

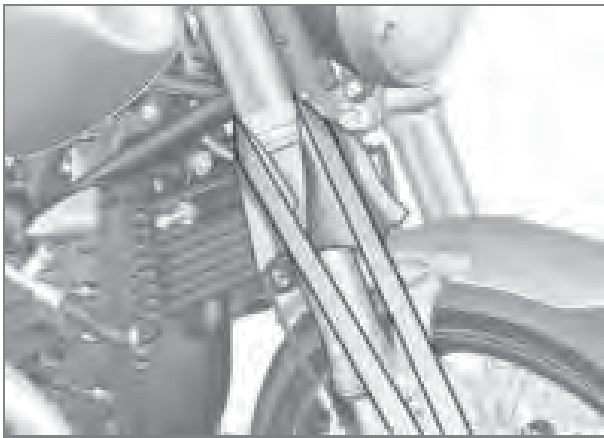

! Components can be damaged. Do not pinch components, e.g. brake lines or wiring harnesses.◀

- Fasten front straps on both sides on lower fork bridge.

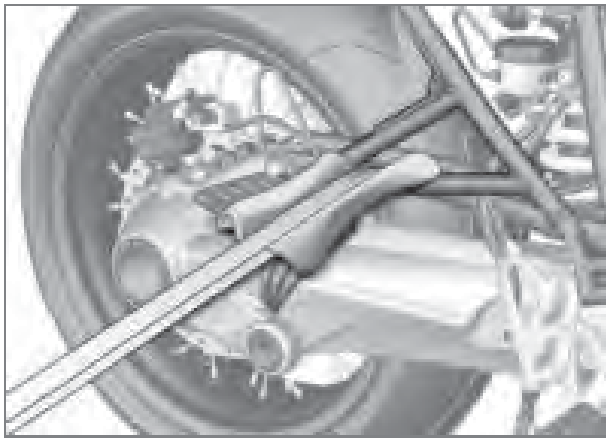

- Fasten rear straps on both sides to the passenger footpegs and then tighten them.
- Tension all straps evenly; the vehicle should be pulled down against its springs with the suspension compressed as much as possible.

Technology in detail

Brake system with BMW Motorrad ABS	64
---	----

Brake system with BMW Motorrad ABS

How does ABS work?

The maximum braking force that can be transferred to the road surface is partially dependent on the friction coefficient of the road surface. Gravel, ice, snow and wet roads offer a considerably lower friction coefficient than a dry, clean asphalt surface. The poorer the friction coefficient of the road surface is, the longer the braking distance will be.

If the maximum transferable braking force is exceeded when the rider increases the brake pressure, the wheels begin to lock and driving stability is lost, and a fall can result. Before this situation occurs, ABS is activated and the brake pressure is adjusted to the maximum transferable braking force. This enables the wheels to continue to turn

and maintains driving stability regardless of the road surface condition.

What happens when rough roads are encountered?

Rough roads can briefly lead to a loss of contact between the tires and the road surface. The transferable braking force is then reduced to zero. If braking is carried out in this situation, ABS must reduce the brake pressure to ensure driving stability when restoring contact to the road. At this point in time, ABS must assume extremely low friction coefficients (gravel, ice, snow) so that the wheels turn in every imaginable case and driving stability is ensured. After detecting the actual conditions, the system adjusts the optimum brake pressure.

Lifting off rear wheel

During extremely heavy and rapid decelerations it is possible that the BMW Motorrad ABS cannot prevent the rear wheel from lifting off the ground. In these cases, the motorcycle can also flip end over end.



Heavy braking can lead to the rear wheel lifting off the ground.

When braking, bear in mind that the ABS control cannot always be relied on to prevent the rear wheel from lifting off the ground.◀

What are the design characteristics of the BMW Motorrad ABS?

The BMW Motorrad ABS ensures driving stability on any surface within the limits of driving physics. The system is not optimized for special require-

ments resulting under extreme weather conditions off-road or on the racetrack.

Special situations

To detect the tendency of the wheels to lock up, the speeds of the front and rear wheel are compared. If implausible values are detected over a longer period of time, the ABS function is deactivated for safety reasons and an ABS error is indicated. The condition for a fault code is the completed self-diagnosis.

Unusual driving conditions can lead to a fault code as well:

- Driving on the rear wheel (wheelie) for a longer period.
- Rear wheel spinning in place with front brake engaged (burn out).
- Heating up on the main or auxiliary stand at idle or with gear engaged.

- Locked-up rear wheel for a longer period of time, e.g. when riding downhill offroad.

Should a fault code occur due to an unusual driving condition, the ABS function can be reactivated by switching the ignition off and then on again.

How important is regular maintenance?



Any technical system is always only as good as its maintenance condition.

To ensure that the BMW Motorrad ABS is in an optimally maintained condition, it is vital that the specified running-in checks be complied with.◀

Reserves for safety

But remember: the potentially shorter braking distances which BMW Motorrad ABS permits must not be used as an excuse

for careless riding. ABS is primarily a means of ensuring a safety margin in genuine emergencies.



Be careful in curves. When you apply the brakes in a curve, the motorcycle's weight and momentum take over and even BMW Motorrad ABS is unable to counteract their effects. The rider is always responsible for adapting his/her driving style. Do not reduce the additional safety provided with risky driving.◀

Maintenance

General instructions	68
Onboard tool kit	68
Front wheel stand	68
Rear-wheel stand	70
Engine oil	71
Brake system	72
Clutch	77
Wheel rims and tires	77
Wheels	77
Headlight	86
Bulbs	87
Jump-starting.....	90
Battery.....	91

General instructions

The "Maintenance" chapter describes work involving the checking and replacement of wear parts that can be performed with a minimum of effort.

If special tightening torques are to be taken into account for assembly, these are listed. An overview of all required tightening torques is contained in the chapter "Technical Data".

Further information about maintenance and repair work can be obtained on DVD through your authorized BMW Motorrad retailer.

Special tools and thorough specialized knowledge are required to carry out some of the work. If you are in doubt, consult an authorized workshop, preferably your authorized BMW Motorrad retailer.

Onboard tool kit

Standard tool kit

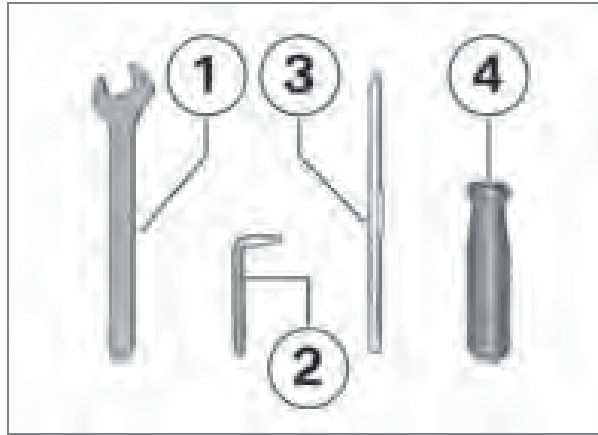

- 1** Open-ended wrench
Wrench size: 14
 - Adjust mirror arm (➡ 37).
- 2** Torx wrench T40
 - Adjusting headlight

- 3** Reversible screwdriver with Phillips and straight blade
 - Adjusting damping on rear wheel (➡ 38).
 - Replacing bulbs for dipped and main-beam headlights (➡ 87).
 - Replacing bulb for parking light (➡ 88).
 - Replacing bulb for front and rear turn indicator (➡ 89).
- 4** Screwdriver handle
 - Top up engine oil (➡ 72).
 - Use with screwdriver bit.

Front wheel stand

Installing front wheel stand

 The front wheel stand is not designed to support the motorcycle without the assistance of a rear stand. A motorcycle standing on the front wheel

stand and the rear wheel alone can fall over.

First place the motorcycle on the rear wheel stand, then raise it with the front wheel stand.◀

- Place motorcycle on a front wheel stand; BMW Motorrad recommends BMW Motorrad front wheel stand.
- Install rear-wheel stand (➡ 70).



- Use basic stand with the mounting pieces. The basic stand and its accessories are available through your

authorized BMW Motorrad retailer.

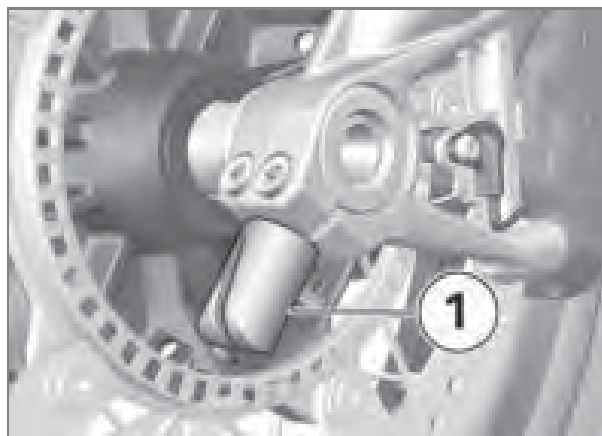

- Insert the mounting pins **1** at the left and right into the front suspension.

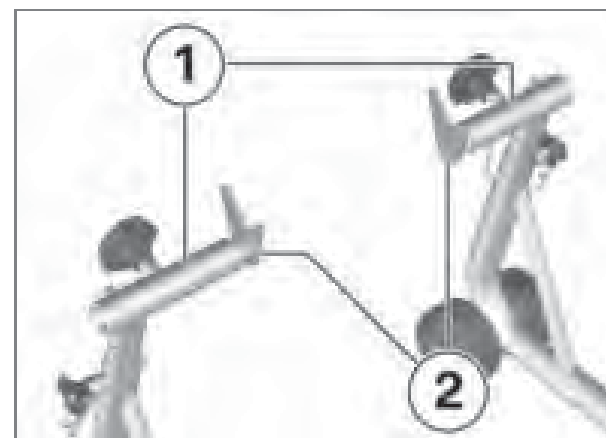

- Turn in the bracket **1** with the long sides facing the inside.
- Adjust the mounting pieces **2** to the width of the pins inserted into the front suspension.
- Adjust height of front wheel stand until front wheel can be turned freely.

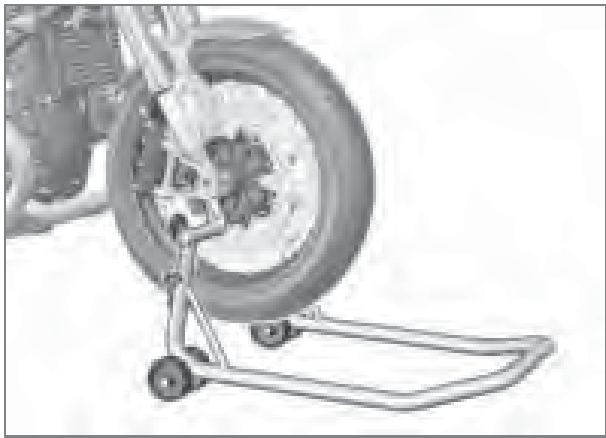

- Attach the front wheel stand to the front suspension and press it on the ground evenly.

Rear-wheel stand

Installing rear-wheel stand

- Make sure ground is level and firm and park motorcycle.
- Use rear wheel stand with rear axle adapter. The rear wheel stand and its accessories are available through your authorized BMW Motorrad retailer.

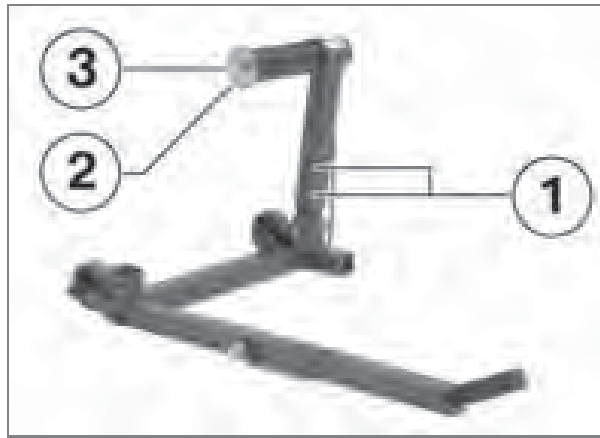

- Set desired height of rear-wheel stand using bolts **1**.
- Remove the lock washer **2**; to do so, press the unlock button **3**.



- Push the rear-wheel stand from the right onto the rear axle.
- Apply the retaining disk from the left; to do so, press the unlock button.

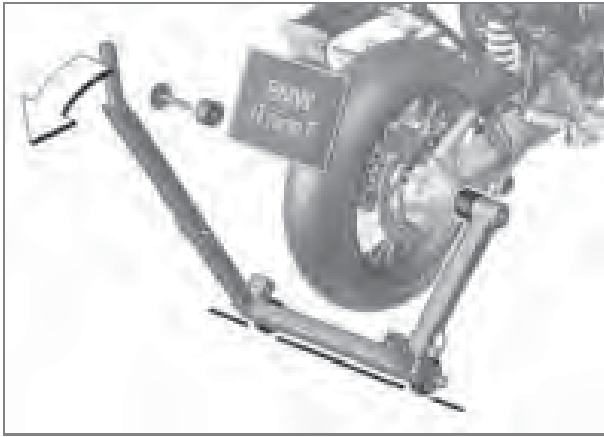

 The motorcycle can tip away to the side and fall over.

Secure motorcycle against tipping away to the side, preferably with the help of a second person.◀

- Position motorcycle upright while simultaneously pressing grip of stand back so that both stand rollers rest on ground.
- Then press the grip down to the ground.

Engine oil

Check engine oil level

 The oil level varies with the temperature of the oil. The higher the temperature, the higher the level of oil in the sump. Checking the oil level with the engine cold or after a short trip leads to misinterpretations of the oil fill quantity.

To ensure that the display of the engine oil level is correct, only check the oil level with the engine at operating temperature.◀

- Switch off engine at operating temperature.
- Make sure ground is level and firm and hold motorcycle vertically.
- Wait five minutes to allow oil to drain to the oil pan.

 To reduce the environmental impact, BMW Motorrad recommends checking the en-

gine oil after every journey of at least 50 km.◀

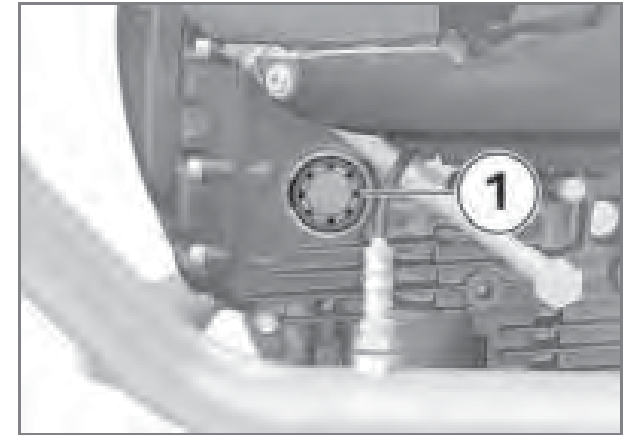

- Read the oil level in the display **1**.

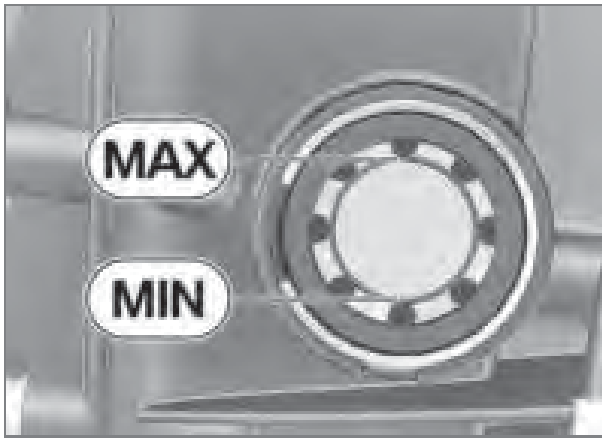

Specified level of engine oil

between MIN and MAX marking

If the oil level is below MIN mark:

- Top up engine oil (➡ 72).

If oil level is above MAX mark:

- Have the oil level corrected at an authorized service facility, preferably an authorized BMW Motorrad retailer.

Top up engine oil

- Make sure ground is level and firm and park motorcycle.

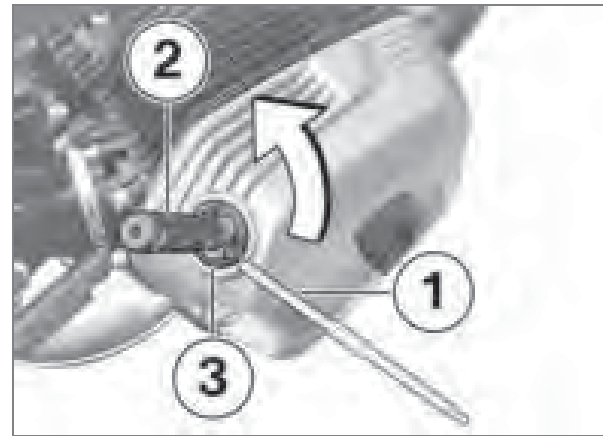

- Clean area adjacent to oil fill location.
- To be able to apply force more easily, insert the interchangeable screwdriver bit **1**, Phillips end first, into the screwdriver handle **2** (from onboard toolkit).
- Apply specified onboard tool to sealing plug **3** of engine oil fill location and remove counter-clockwise.



Both too little and too much engine oil can lead to engine damage.

Always make sure that the oil level is correct.◀

- Add engine oil up to specified level.



Engine oil, quantity for topping up

max 0.5 quarts (max 0.5 l) (Difference between MIN and MAX)

- Check engine oil level (➡ 71).
- Install sealing plug **3** of engine oil fill location.

Brake system

Checking brake operation

- Actuate the handbrake lever.
 - » Pressure point must be clearly perceptible.
- Actuate the footbrake lever.

» Pressure point must be clearly perceptible.

If no clear pressure points are perceptible:

 Incorrect working practices endanger the reliability of the brakes.

Have all work on the brake system carried out by specialists. ◀

- Have the brakes checked at an authorized workshop, preferably an authorized BMW Motorrad retailer.

Check front brake pad thickness

- Make sure ground is level and firm and park motorcycle.



- Visually inspect left and right brake pads to determine their thickness. Viewing direction: between wheel and front suspension toward brake pads **1**.

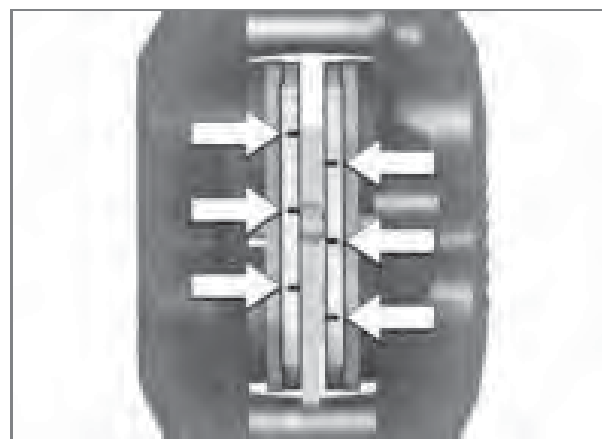

 Front brake-pad wear limit

0.04 in (1.0 mm) (Only friction material without carrier plate. Wear markings (grooves) must be clearly visible.)

If the wear indicators are no longer clearly visible:

 Dropping below the minimum pad thickness leads to reduced braking performance and may result in damage to the brakes.

In order to ensure the operating reliability of the brake system,

make sure that the brake pads are not worn beyond their minimum thickness.◀

- Have the brake pads replaced at an authorized service facility, preferably an authorized BMW Motorrad retailer.

Checking rear brake pad thickness

- Make sure ground is level and firm and park motorcycle.



- Conduct a visual inspection of the brake pad thickness. Direc-

tion of view: from left to brake caliper.

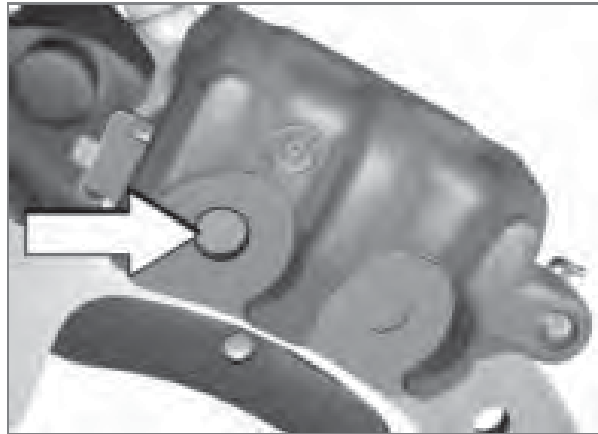

Rear brake-pad wear limit

0.04 in (1.0 mm) (Only friction material without carrier plate. Brake disk must not be visible through bore hole of inner brake pad.)

If the brake rotor is visible:



Dropping below the minimum pad thickness leads to reduced braking performance

and may result in damage to the brakes.

In order to ensure the operating reliability of the brake system, make sure that the brake pads are not worn beyond their minimum thickness.◀

- Have the brake pads replaced at an authorized service facility, preferably an authorized BMW Motorrad retailer.

Brake pad wear

The rear brake has a brake-pad wear indicator.

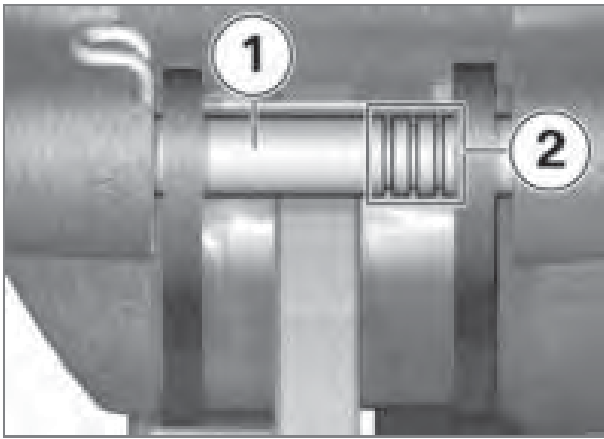

Shaft **1** with three marker rings **2** is between the brake pads.

How to interpret the marks:

- 3 rings visible: brake-pad thickness is at least 75 %
- 2 rings visible: brake-pad thickness is at least 50 %
- 1 ring visible: brake-pad thickness is at least 25 %
- No rings visible: brake pads worn to wear limit; check as described above

Check front brake fluid level

 A low fluid level in the brake reservoir can allow air to penetrate the brake system. This significantly reduces braking efficiency. Check brake fluid level regularly. ◀

- Make sure ground is level and firm and park motorcycle.
- Brake-fluid reservoir horizontal, motorcycle standing upright.

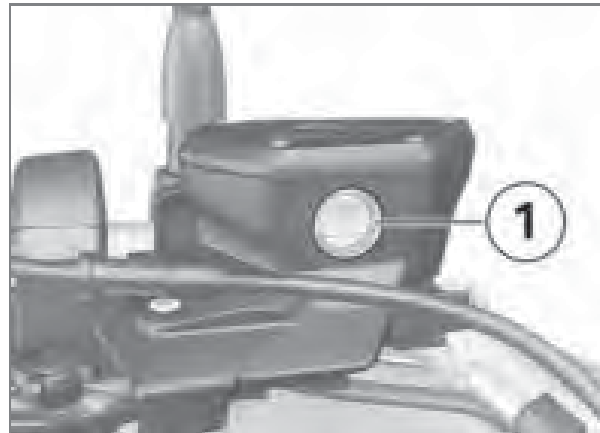

- Check brake fluid level in front brake-fluid reservoir **1**.

 The brake fluid level in the brake-fluid reservoir drops due to brake pad wear. ◀

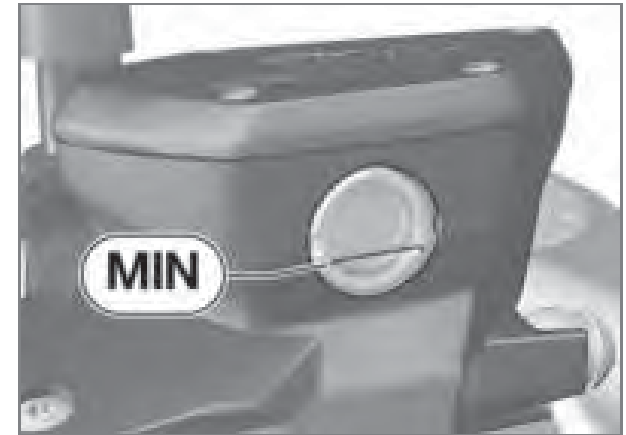

 Front brake fluid level

Brake fluid, DOT4

The brake fluid level must not fall below the MIN mark. (Brake-fluid reservoir horizontal, motorcycle standing upright.)

If brake fluid level falls below the approved level:

- Have the defect corrected as soon as possible by an authorized workshop, preferably an authorized BMW Motorrad retailer.

Checking rear brake fluid level



A low fluid level in the brake reservoir can allow air to penetrate the brake system. This significantly reduces braking efficiency.

Check brake fluid level regularly.◀

- Make sure ground is level and firm and park motorcycle. Hold motorcycle straight.

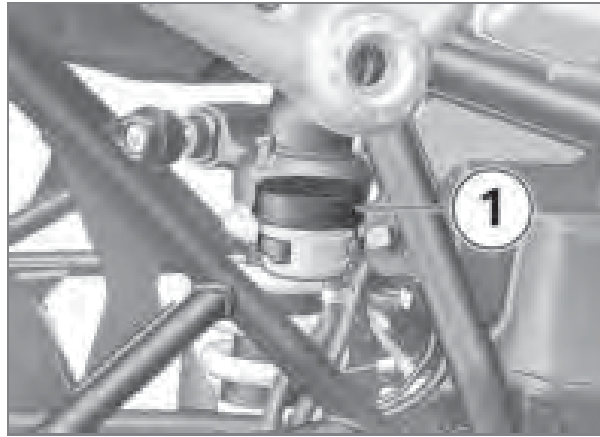

- Read brake fluid level at rear brake-fluid reservoir **1**.



The brake fluid level in the brake-fluid reservoir drops due to brake pad wear.◀



Rear brake fluid level

Brake fluid, DOT4

The brake fluid level must not fall below the MIN mark. (Brake-fluid reservoir horizontal)

If brake fluid level falls below the approved level:

- Have the defect corrected as soon as possible by an authorized workshop, preferably an authorized BMW Motorrad retailer.

Clutch

Check clutch function

- Pull back the clutch lever.
 - » Pressure point must be clearly perceptible.

If no clear pressure point can be felt:

- Have the clutch checked by an authorized workshop, preferably an authorized BMW Motorrad retailer.

Wheel rims and tires

Check wheel rims

- Make sure ground is level and firm and park motorcycle.
- Subject wheel rims to visual inspection for defects.
- Have damaged rims checked and, if necessary, replaced by a specialist service facility, preferably an authorized BMW Motorrad retailer.

Checking spokes

- Make sure ground is level and firm and park motorcycle.
- Sweep across spokes with a screwdriver handle or similar item, paying attention to the sound that they emit as you proceed.

If the tone does not remain consistent:

- Have spokes checked by an authorized service facility, preferably an authorized BMW Motorrad retailer.

Checking tire tread depth



The handling of your motorcycle can already change for the worse before the legally prescribed minimum tread depth is reached.

Have tires replaced even before the minimum tread depth is reached.◀

- Make sure ground is level and firm and park motorcycle.
- Measure tire tread depth in main tread grooves with wear indicating marks.



Tread wear marks are integrated into the main grooves on every tire. If the tire tread has worn down to the level of the marks, the tire is completely worn. The locations of the marks are indicated on the edge of the tire, e.g. by the letters TI, TWI or by an arrow.◀

When the minimum tread depth is reached:

- Replace tires concerned.

Wheels

Tire recommendation

For every size of tire, BMW Motorrad has tested and approved certain makes as roadworthy. BMW Motorrad cannot evaluate the suitability of

other tires, and can therefore take no responsibility for their driving safety.

BMW Motorrad recommends only using the tires tested and approved by BMW Motorrad. Extensive information is available at your authorized BMW Motorrad retailer or on the Internet at "www.bmw-motorrad.com".

Affect of wheel size on ABS

Wheel sizes greatly affect the function of the ABS system. Especially the diameter and width of the wheels are stored in the control unit as the basis for all necessary calculations. A change in these sizes due to conversion to wheels not installed as standard equipment can seriously affect the control comfort of these systems.

The sensor rings required for wheel speed detection must also match the control systems installed and may not be replaced. If you want to equip your motorcycle with different wheels, please speak to a specialist service facility, and preferably a BMW Motorrad retailer. In some cases the data stored in the control units can be adapted to the new wheel sizes.

Remove front wheel

 To simplify wheel removal/installation, the front wheel cover must be released on one side.◀

- Make sure ground is level and firm and park motorcycle.

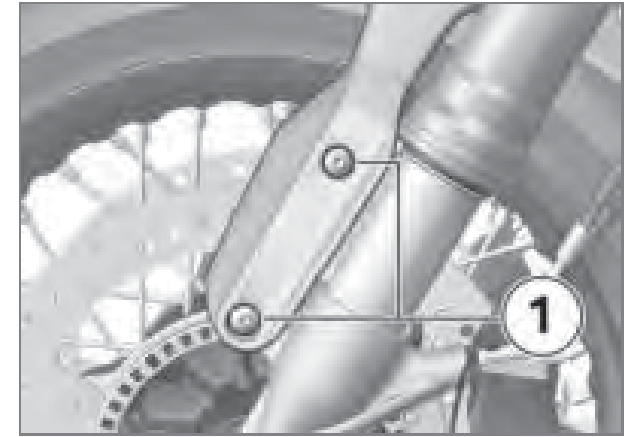

- Loosen screws **1**.
- Mask off areas of wheel rim that could be scratched in the process of removing the brake calipers.

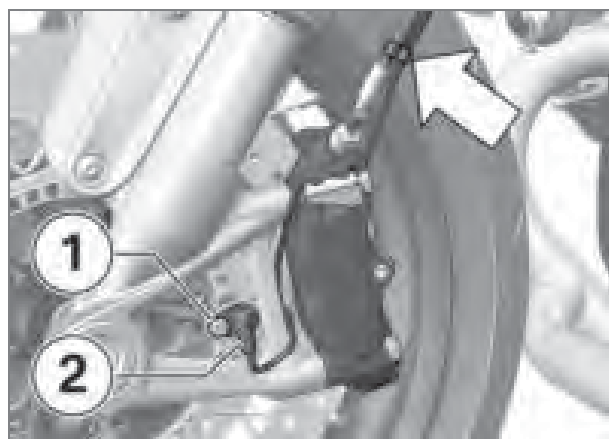

- Remove sensor cable **arrow** from bracket.
- Remove screw **1** and take wheel speed sensor **2** out of bore.

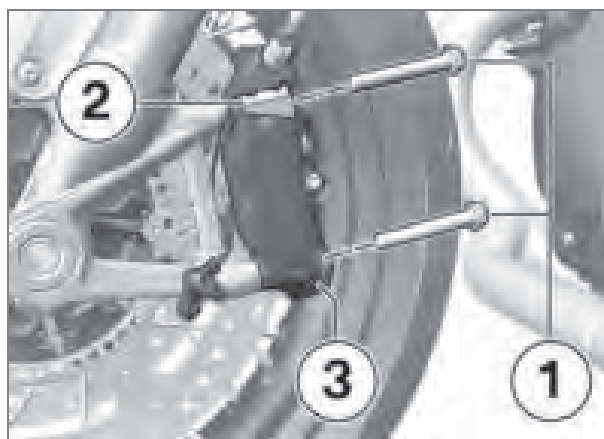

! Once the calipers have been removed, there is a risk of the brake pads being pressed together to the extent that they cannot be slipped back over the brake rotor on reassembly.

Do not operate the handbrake lever when the brake calipers have been removed. ◀

- Remove screws **1** on left.
- Detach bracket **2** for sensor cable and brake caliper **3**.

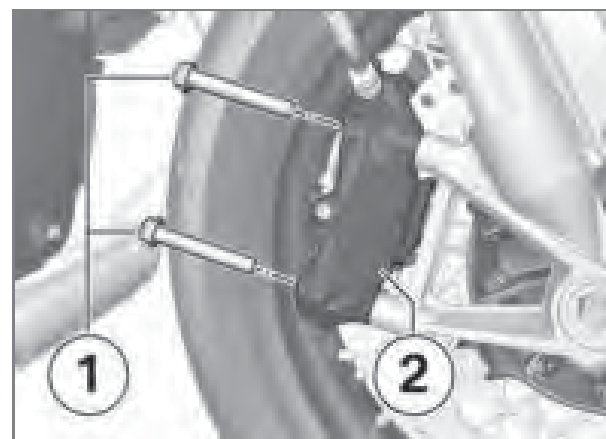

- Remove screws **1** on right and detach brake caliper **2**.

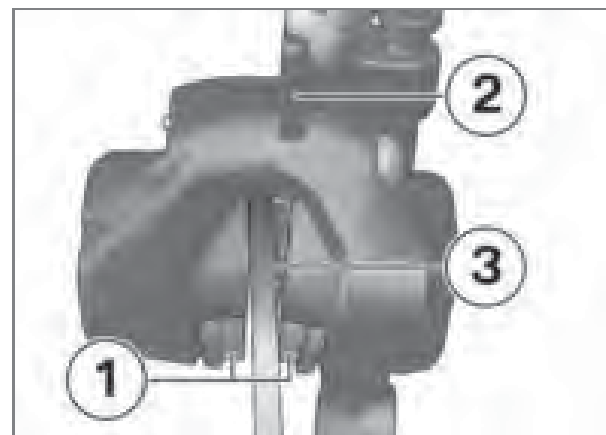

- Push brake pads **1** slightly apart by turning the brake caliper **2** back and forth against the brake rotor **3**.

- Carefully pull brake calipers back and outward to remove them from the brake rotors.

 The motorcycle can tip away to the side and fall over.

Secure motorcycle against tipping away to the side, preferably with the help of a second person. ◀

- Raise motorcycle, preferably with a BMW Motorrad rear-wheel stand.
- Install rear-wheel stand (➡ 70).

 The BMW Motorrad front wheel stand is not designed to support the motorcycle without the assistance of an auxiliary stand. A motorcycle standing on the front wheel stand and the rear wheel alone can fall over. Place the motorcycle on an auxiliary stand before lifting the front wheel with the BMW Motorrad front-wheel stand. ◀

- Raise front of motorcycle, preferably using a BMW Motorrad front wheel stand, until front wheel can rotate freely.
- Install front wheel stand (➡ 68).

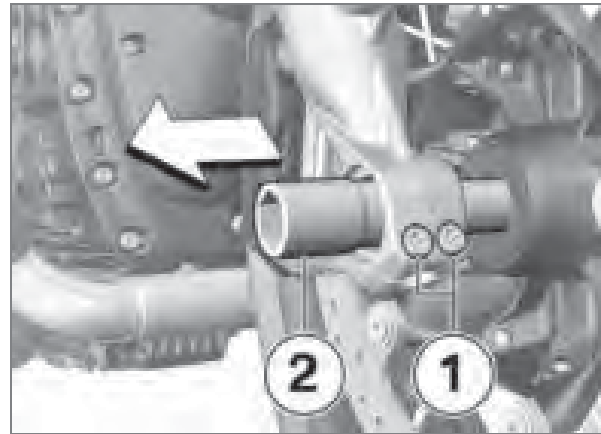

 The left clamping device fixes the threaded bush in place in the front suspension. A poorly aligned threaded bush results in incorrect spacing between the sensor ring and the sensor, and therefore to ABS malfunctions or destruction of the sensor.

To ensure the proper alignment of the threaded bush, do not loosen or remove the left clamping device. ◀

- Loosen axle clamping screws **1**.
- Remove quick-release axle **2** while supporting wheel.
- Do not wipe off grease on axle.
- Roll front wheel forward to remove.

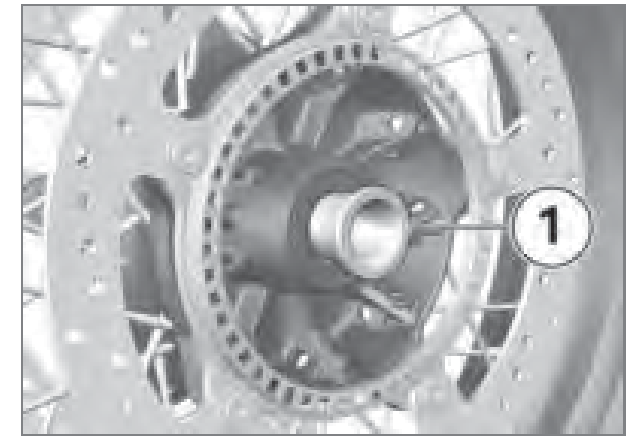

- Remove spacing bushing **1** on left side from front wheel hub.

Install front wheel

 Malfunctions may occur during control interventions by ABS if a wheel other than the standard wheel is installed. Please see the information on the effect of wheel sizes on the ABS system at the beginning of this chapter.◀

 Threaded fasteners not tightened to the specified torque can work loose or their threads can suffer damage. Always have the tightening torques checked by a specialized workshop, preferably an authorized BMW Motorrad retailer.◀



- Mount spacing bushing **1** on left side in wheel hub.

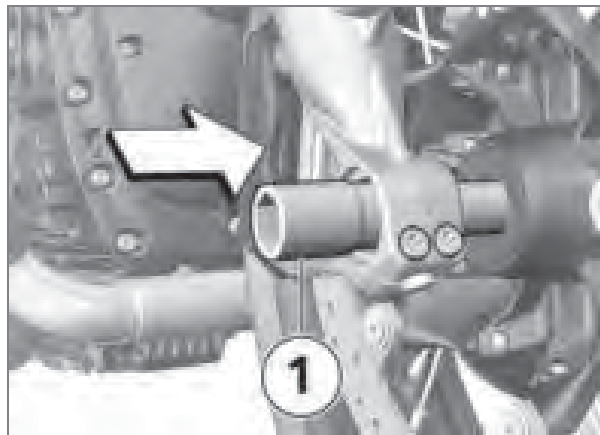

- Lubricate quick-release axle **1**.

 Lubricant
Optimoly TA

 The front wheel must be installed right way round to rotate in the correct direction. Observe the direction of rotation arrows on the tires or on the rim.◀

- Roll front wheel into front suspension.

 Quick-release axle is not correctly tightened. After the brake caliper is fastened and the spring fork is relaxed, tighten the quick-release axle and axle clamping with the specified torque.◀

- Raise front wheel and mount quick-release axle **1** and fasten loosely.

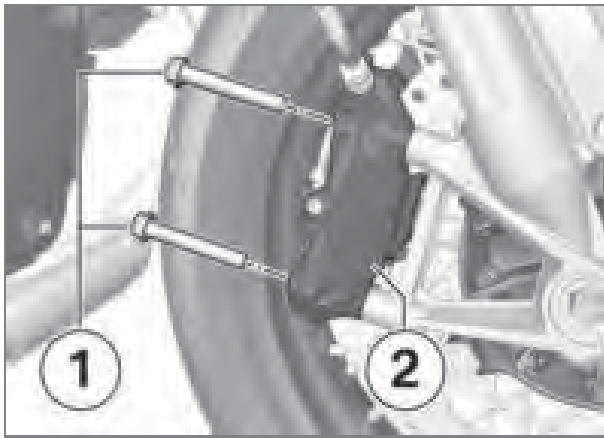

- Position brake caliper **2** on right and install screws **1**.



Brake caliper on telescopic forks

28 lb/ft (38 Nm)

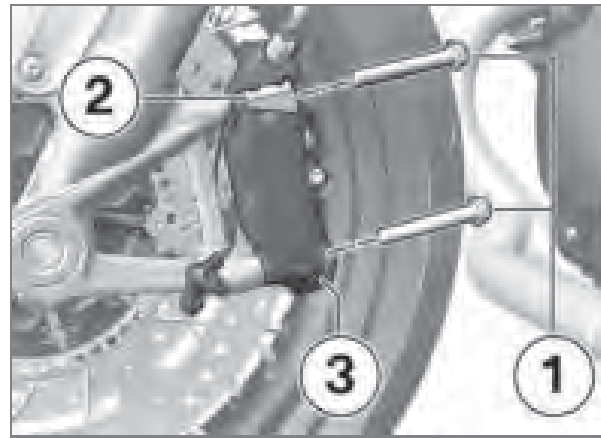

- Lay on brake caliper **3** on left and bracket **2**.
- Install screws **1**.



Brake caliper on telescopic forks

28 lb/ft (38 Nm)

- Remove adhesive tape from wheel rim.

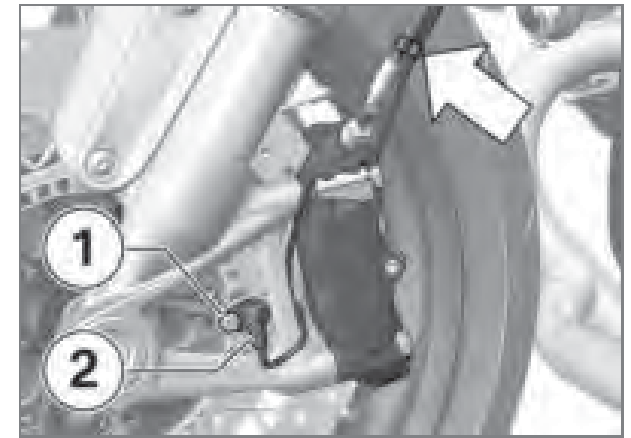

- Fasten sensor cable **arrow** on brake line.
- Insert wheel speed sensor **2** in bore and install with screw **1**.



Braking efficiency is impaired if the brake pads are not correctly bedded against the disks.

Before driving off, check that the braking effect kicks in without any delay. ◀

- Engage the brakes repeatedly, continuing until the brake pads seat against the rotors.
- Remove front wheel stand.
- Extend side stand.

 The motorcycle can tip away to the side and fall over.

Secure motorcycle against tipping away to the side, preferably with the help of a second person. ◀

- Remove rear wheel stand.
- Place motorcycle on its side stand.

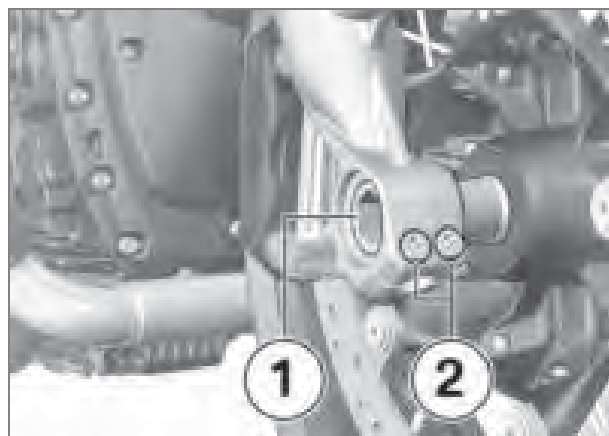

- Firmly compress front forks.
- Tighten quick-release axle **1**.

 Quick-release axle in axle mount

37 lb/ft (50 Nm)

- Tighten axle clamping screws **2**.



 Clamping screws (quick-release axle) in axle mount

Tightening sequence: Tighten each screw 3 times diagonally

14 lb/ft (19 Nm)

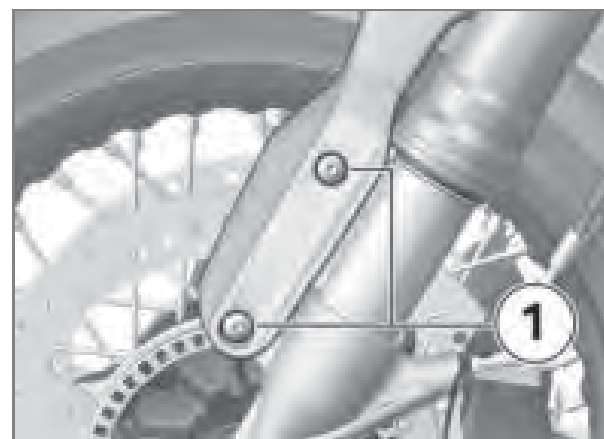

- Tighten screws **1**.

 Front wheel cover on fork

4 lb/ft (5 Nm)

Remove rear wheel

- Make sure ground is level and firm and park motorcycle.
- Install rear-wheel stand (➡ 70).

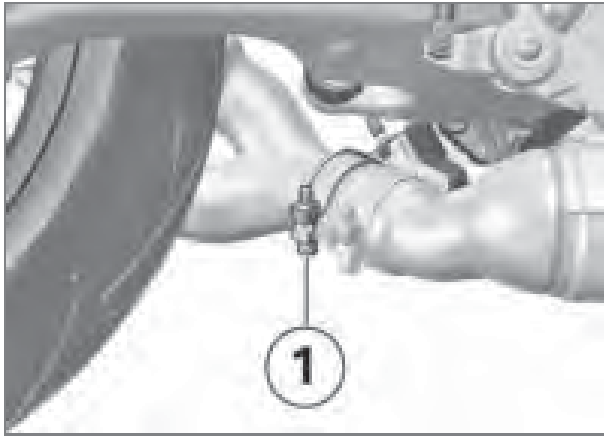

⚠ Risk of skin burns from hot exhaust system.

Do not touch hot parts of the exhaust system. ◀

- Loosen screw **1** of clip and slide clip toward rear.
- Do not remove sealing grease from clip.

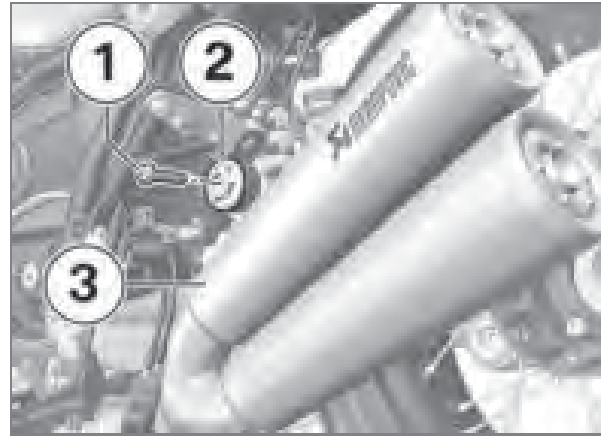

- Remove screw **1** and fastening washer **2** of muffer bracket from passenger footrest.
- Pull off muffler **3** toward rear and lay on a soft surface.
- Shift into first gear.

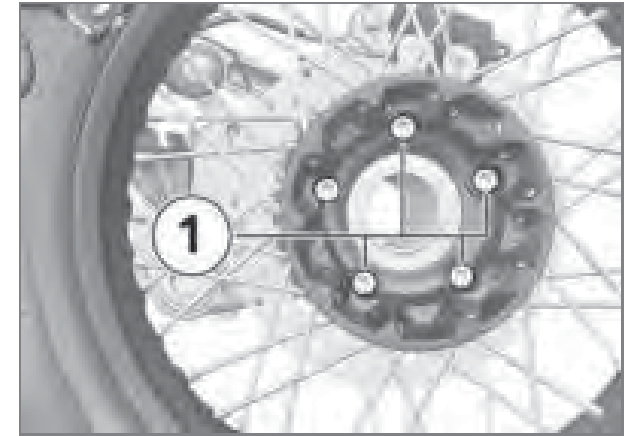

- Remove screws **1** while supporting wheel.
- Roll rear wheel out toward rear.

Installing rear wheel

⚠ Malfunctions may occur during control interventions by ABS if a wheel other than the standard wheel is installed.

Please see the information on the effect of wheel sizes on the ABS system at the beginning of this chapter. ◀

- Place rear wheel on rear wheel support.

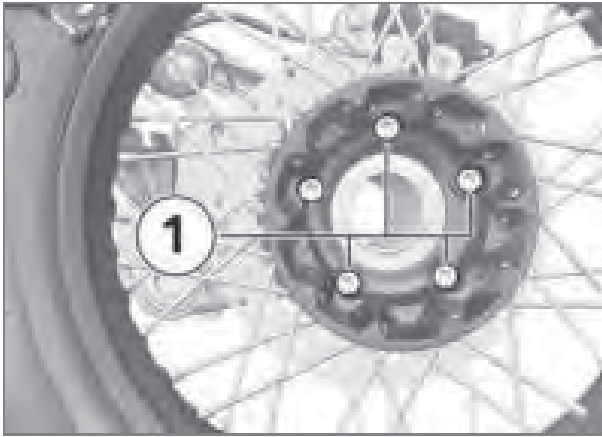

- Install screws **1**.

 Rear wheel on wheel carrier
Tightening sequence: Diagonally
44 lb/ft (60 Nm)

- Mount muffler on pipe on exhaust flap.

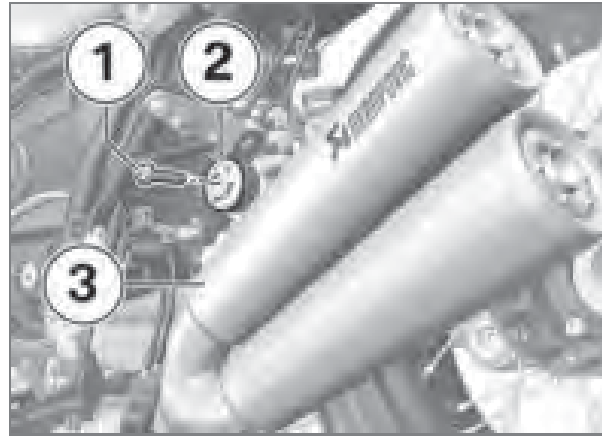

- Align muffler **3**, lay on fastening washer **2** and install screw **1**.

 Muffler on passenger frame
7 lb/ft (10 Nm)

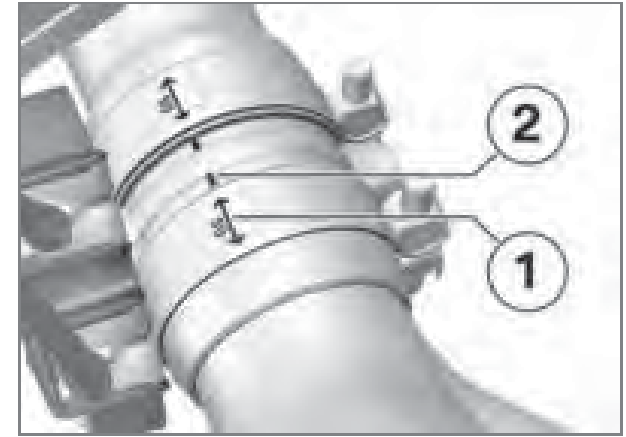

- Slide clip as far forward as possible and align so that clamp marking **(GS) 1** faces marking **2**.

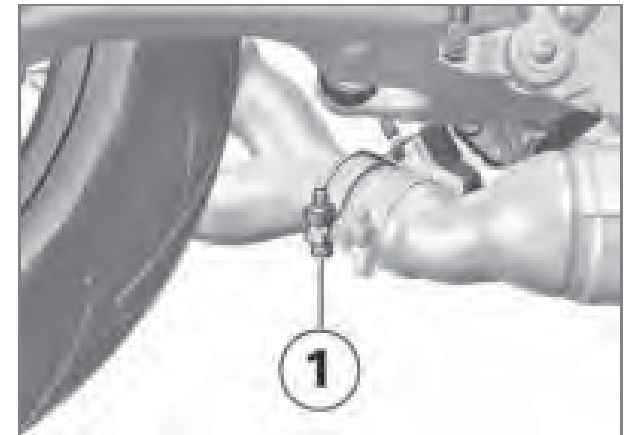

- Tighten screw **1**.



Clip on muffler and exhaust manifold

18 lb/ft (25 Nm)

Headlight

Removing and installing light housing

- Switch off ignition (➡ 30).
- Make sure ground is level and firm and park motorcycle.

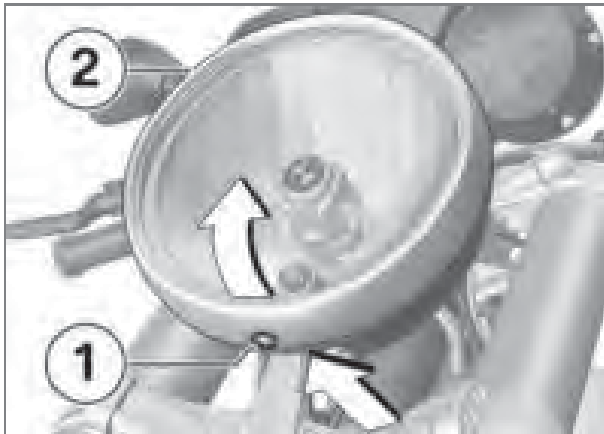

- Loosen screw **1** with several rotations.

- Carefully pull light housing **2** in lower area forward toward (**arrow**) and remove upward.

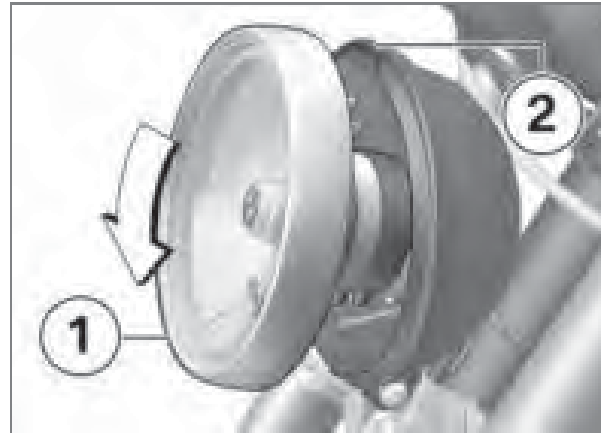

- Lay on light housing **1** behind lug **2** and swivel downward.
- Align light housing **1** in center.

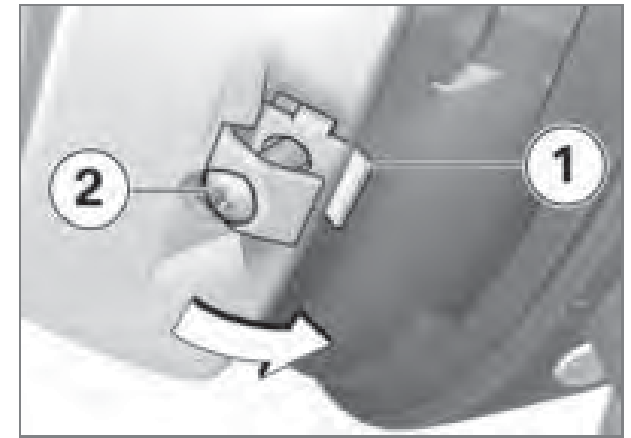

! The clips can be compressed by striking the light housing once. As a result secure fastening of the light housing is no longer ensured. Do not use force.◀

- Press screw **2** upward with screwdriver.
- Swivel light housing toward rear.
- » Clip **1** engages in light housing.
- Tighten screw **2**.

Bulbs

Replacing bulbs for dipped and main-beam headlights

- Switch off ignition (⇒ 30).
- Make sure ground is level and firm and park motorcycle.
- Remove light housing (⇒ 86).

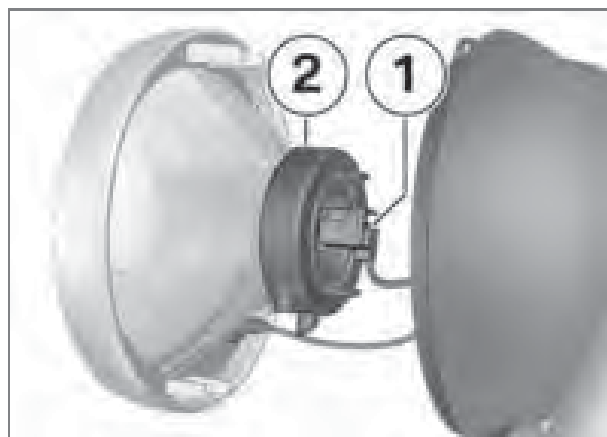

- Disconnect connector **1** for low-beam and high-beam headlight.
- Pull rubber seal **2** off light housing.

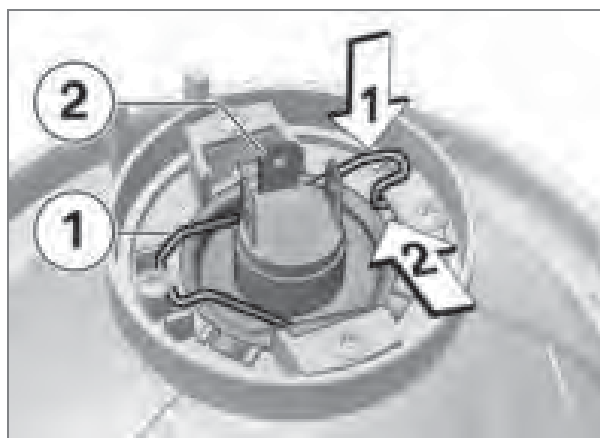

- Press wire spring **1** downward and swivel to side out of catch, then fold open wire spring upward.
- **Carefully** remove bulb **2** for low-beam and high-beam headlight from light housing.
- Replace defective bulb.

 Bulb for low-beam and high-beam headlight

H4 / 12 V / 60/55 W

- To protect the glass against soiling, only grasp the bulb by the base.

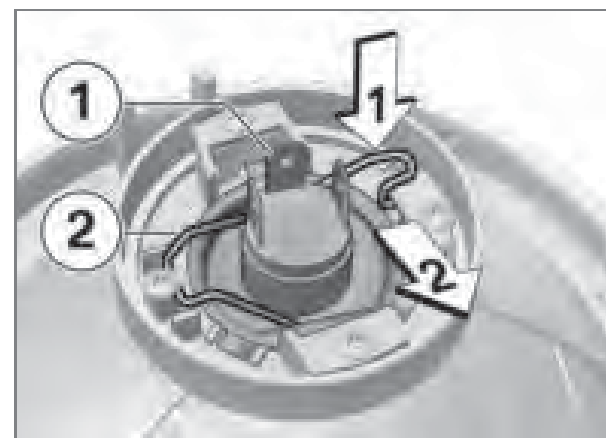

- Mount bulb **1** in light housing.
- Fold wire spring **2** closed and swivel into catch.

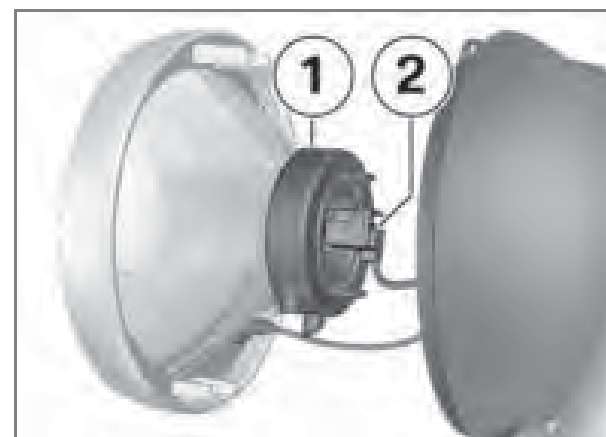

- Mount rubber cap **1**.
- Connect connector **2** for low-beam and high-beam headlight.

- Install light housing.

Replacing bulb for parking light

- Switch off ignition (➡ 30).
- Make sure ground is level and firm and park motorcycle.
- Remove light housing (➡ 86).

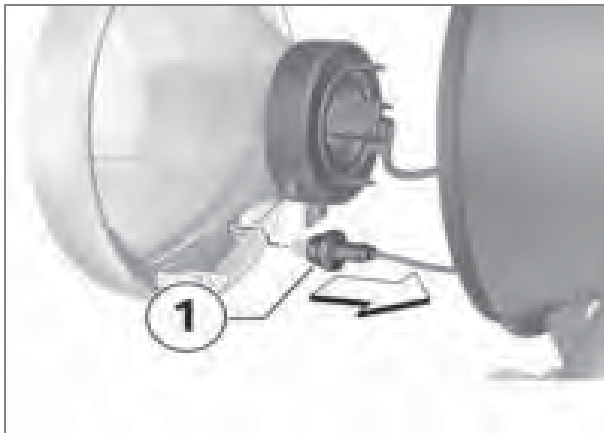

- Pull socket **1** for parking light out of light housing.

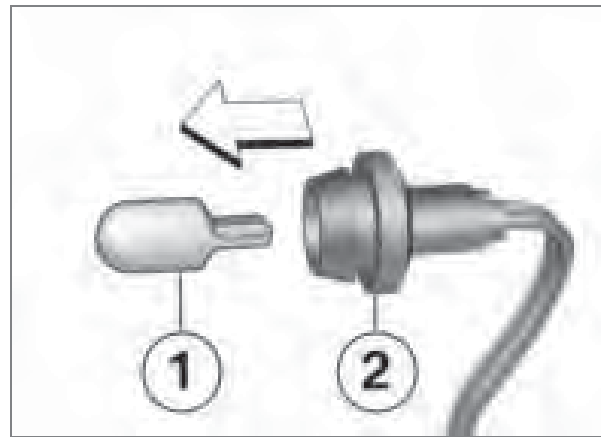

- Pull bulb **1** out of socket **2**.
- Replace defective bulb.



Bulb for parking light

W5W / 12 V / 5 W

- To prevent contaminants from being deposited on the glass surface, always use a clean, dry cloth to hold the bulb.

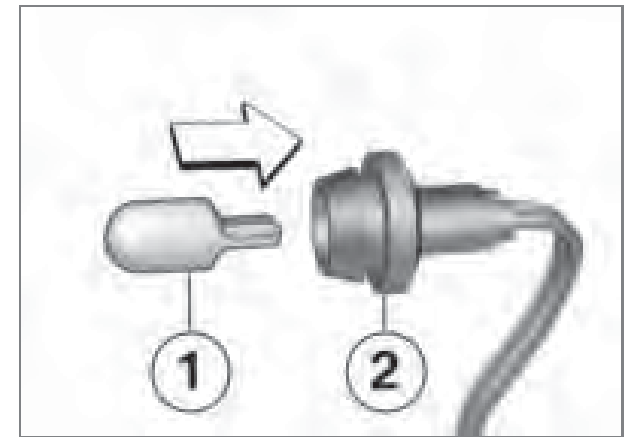

- Insert bulb **1** for parking light into socket **2**.

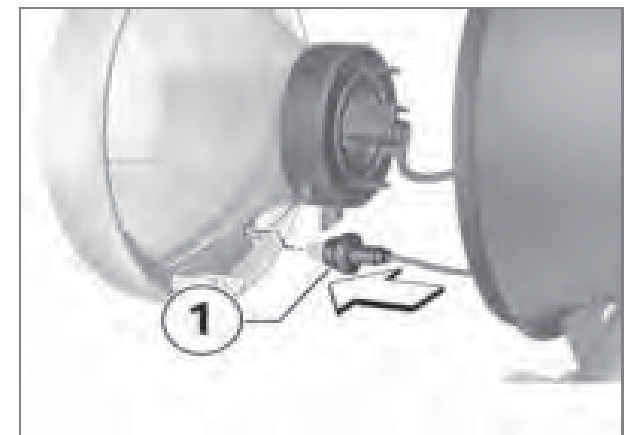

- Mount socket **1** for parking light in light housing.
- Install light housing.

Replacing bulb for front and rear turn indicator

- Switch off ignition (🔌 30).
- Make sure ground is level and firm and park motorcycle.



- Remove screw **1**.

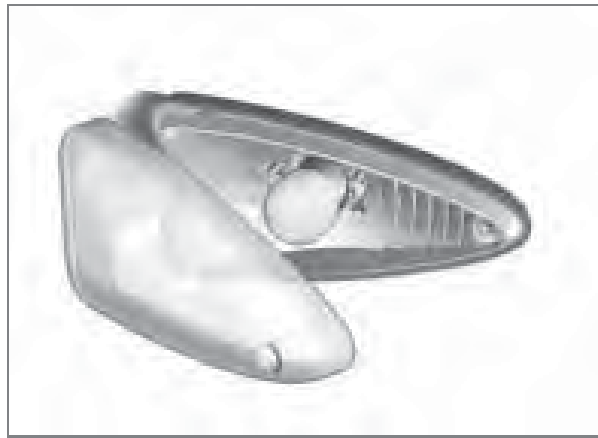

- Pull glass on screw connection side out of light housing.

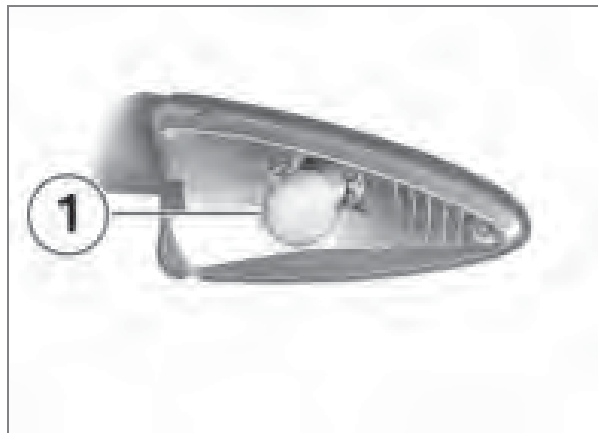

- Remove bulb **1** from light housing by turning it counterclockwise.

- Replace defective bulb.

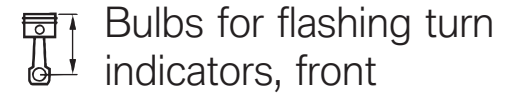

RY10W / 12 V / 10 W

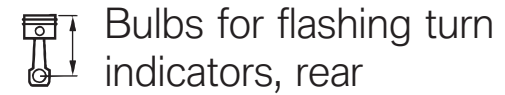

RY10W / 12 V / 10 W

- To prevent contaminants from being deposited on the glass surface, always use a clean, dry cloth to hold the bulb.

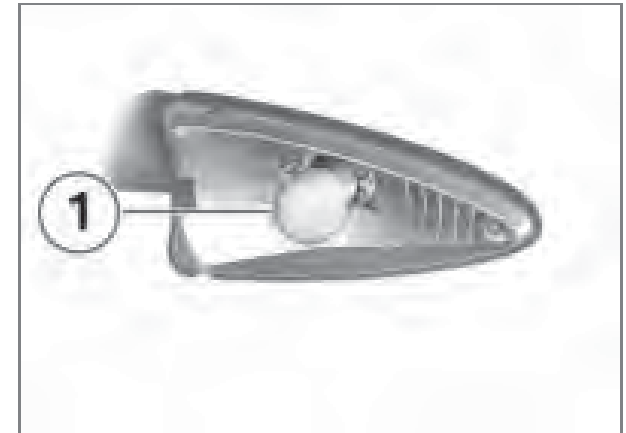

- Install bulb **1** by turning clockwise in light housing.

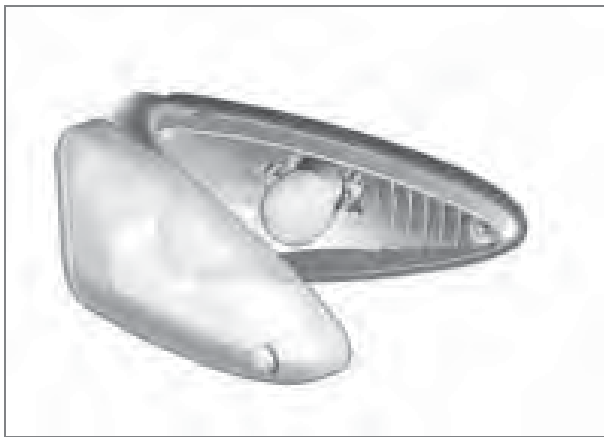

- Insert inside end of lens into light housing and close.



- Install screw **1**.

Replacing LED tail light

The LED tail light can only be completely replaced.

- Please contact a specialist service facility for this purpose, preferably an authorized BMW Motorrad retailer.

Jump-starting

 The wires leading to the power socket do not have a load-capacity rating adequate for jump-starting the engine. Excessively high current can lead to a cable fire or damage to the vehicle electronics.

Do not use the socket to jump-start the engine of the motorcycle. ◀

 A short-circuit can result if the crocodile clips of the jump leads are accidentally brought into contact with the motorcycle.

Use only jump leads fitted with

fully insulated crocodile clips at both ends. ◀

 Jump-starting with a donor-battery voltage higher than 12 V can damage the motorcycle electronics.

The battery of the donor vehicle must have a voltage of 12 V. ◀

- Make sure ground is level and firm and park motorcycle.
- Remove passenger seat (➡ 41).
- Remove rider's seat (➡ 40).

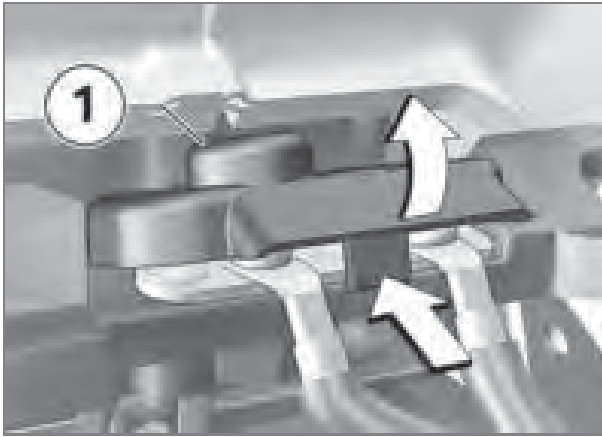

- Unclip cover **1** in lower area **arrow** and remove upward.

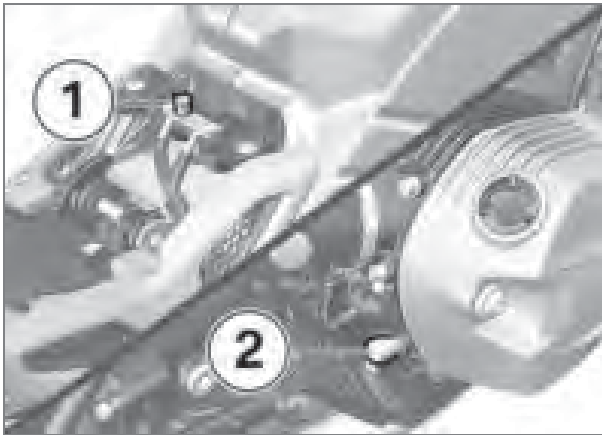

- Begin by connecting one end of red jumper cable to positive battery connection point **1** and

other end to positive terminal of second battery.

- Then connect one end of black jumper cable to a screw terminal **2** on your own motorcycle and other end to negative terminal of second battery.
- Run engine of donor vehicle during jump-starting procedure.
- Start engine of vehicle with discharged battery in usual way; if engine refuses to start, wait a few minutes before repeating attempt to protect starter and supporting battery.
- Allow both engines to idle for a few minutes before disconnecting jumper cables.
- First disconnect jumper cable from screw terminal **2**, then from positive battery connection point **1**.



To start the engine, do not use start sprays or similar items.◀

Battery

Maintenance instructions

Correct battery maintenance combined with proper charging and storage procedures extends the battery's service life, and is also required for warranty claims. Compliance with the points below is important in order to maximize battery life:

- Keep the surface of the battery clean and dry
- Do not open the battery
- Do not top up with water
- Be sure to read and comply with the instructions for charging the battery on the following pages
- Do not turn the battery upside down.



If the battery is not disconnected, the onboard electronics (clock etc.) will drain the battery. This can cause the battery to run flat. If this happens,

warranty claims will not be accepted.

During driving breaks of more than 4 weeks, a trickle-charger should be connected to the battery.◀



BMW Motorrad has developed a trickle-charger specially designed for compatibility with the electronics of your motorcycle. Using this charger, you can keep the battery charged during long periods when the motorcycle is not being used without having to disconnect the battery from the motorcycle's onboard systems. Additional information is available at your authorized BMW Motorrad retailer.◀

Charging connected battery

- Remove devices connected to onboard sockets.



Charging the connected battery directly at the battery terminals can damage the motorcycle electronics.

To charge the battery via the battery terminals, disconnect the battery first.◀



Charging the battery via the onboard socket is only possible with suitable chargers. Unsuitable chargers can result in damage to the motorcycle electronics.

Use suitable BMW chargers. The correct charger is available through your authorized BMW Motorrad retailer.◀



If the multifunction display and indicator lamps fail to light up when you switch on the ignition, the battery is completely discharged (battery voltage below 9 V). Attempts to recharge a completely discharged battery through the onboard power

socket can damage the motorcycle's electronic systems.

Always charge a completely drained battery directly at the terminals of the disconnected battery.◀

- Charge disconnected battery via onboard socket.



The motorcycle's onboard electronics know when the battery is fully charged. The onboard socket is switched off when this happens.◀

- Comply with operating instructions of charger.



If you are unable to charge the battery via the onboard socket, you may be using a charger that is not compatible with your motorcycle's electronics. In this case, charge the battery directly at the terminals of the disconnected battery.◀

Charging disconnected battery

- Charge battery using a suitable charger.
- Comply with operating instructions of charger.
- Once the battery is fully charged, disconnect the charger's terminal clips from the battery terminals.



In the case of longer periods when the motorcycle is not being used, the battery must be recharged regularly. See the instructions for caring for your battery. Always fully recharge the battery before returning it to use.◀

Replacing battery

If the battery is defective, please contact a specialized workshop, preferably an authorized BMW Motorrad retailer.

Accessories

General instructions	96
Onboard power sockets	96
Luggage	97
Passenger frame.....	97
Installing passenger frame	101

General instructions



BMW Motorrad cannot examine or test each product of outside origin to ensure that it can be used on or in connection with BMW motorcycles without constituting a safety hazard. Nor is this guarantee provided when the official approval of a specific country has been granted. Tests conducted by these instances cannot make provision for all operating conditions experienced by BMW motorcycles and, consequently, they are not sufficient in some circumstances.

Use only parts and accessories approved by BMW for your motorcycle. ◀

The safety, function and suitability of the parts and accessory products have been checked extensively by BMW. Therefore, BMW assumes responsibility for these products. BMW shall not

be liable for unapproved parts and accessory products of any kind.

Whenever you are planning modifications, comply with all the legal requirements. The vehicle must not infringe on national road-vehicle construction and use regulations of your country. Your authorized BMW Motorrad retailer offers you qualified advice when choosing genuine BMW parts, accessories and other products.

You will find all BMW Motorrad optional accessories on our website: "www.bmw-motorrad.com".

Onboard power sockets

Information on using onboard power sockets:

Automatic deactivation

The power sockets are automatically deactivated under the following conditions:

- if the battery's voltage falls below the level required to start the vehicle
- if the maximum electrical load specified in the "Technical data" is exceeded
- during starting.

Connection of electrical devices

The ignition must be switched on before electrical devices connected to the power sockets can be operated. To reduce loads on the onboard electrical system the sockets are deactivated no more than 15 minutes after the ignition is switched off.

Cable routing

Observe the following when routing cable from power sockets to additional devices:

- Driver must not be impaired by cable.
- Steering angle and handling characteristics must not be restricted.
- Do not kink or pinch cable.

Luggage

Securing luggage on motorcycle

 Overloading and imbalanced loads can adversely affect the motorcycle's handling. Do not exceed the gross weight limit and observe the loading information.◀

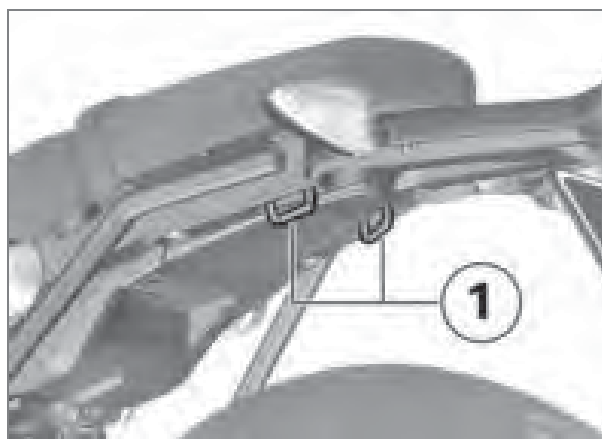

Secure luggage (e.g. rear bag) on lashing eyes **1**.

Additional information on luggage systems and their fastening is available at your authorized BMW Motorrad retailer.

Passenger frame

Removing passenger frame

 Paintwork can be scratched and/or damaged.

Use suitable surface or tape off endangered area.◀

 The installation of an additional OA (muffler bracket) is essential for removing the passenger frame.

Detailed information can be obtained from your authorized BMW Motorrad retailer or online at www.bmw-motorrad.com. Also observe the general information at the beginning of this chapter.◀

- Make sure ground is level and firm and park motorcycle.
- Install rear-wheel stand (▣➔ 70).
- Remove passenger seat (▣➔ 41).
- Remove rider's seat (▣➔ 40).

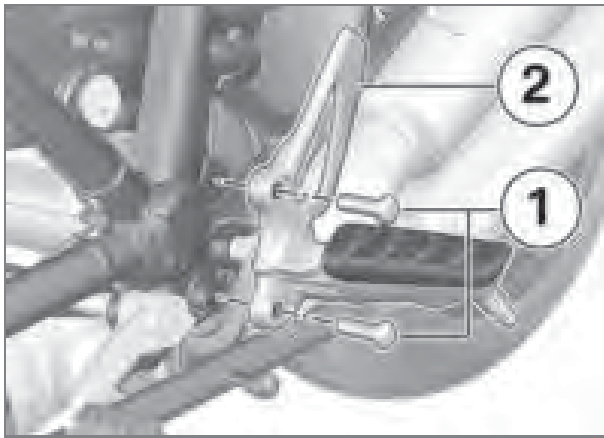

- Remove screws **1** and take off footrest system **2** on left.



Paintwork can be scratched and/or damaged.

Use suitable surface or tape off endangered area.◀

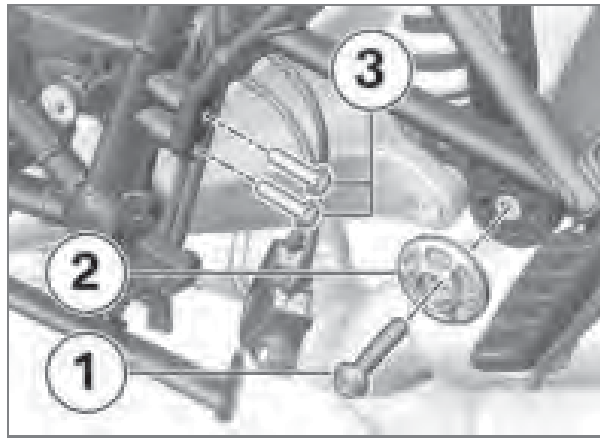

- Remove screw **1** and washer **2**.
- Remove screws **3**.

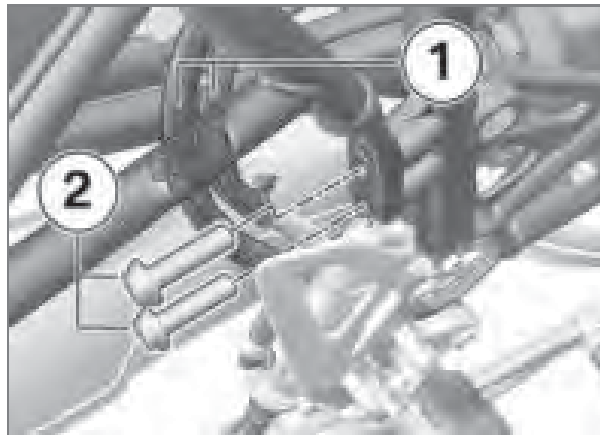

Components can be damaged.

Do not pinch components, e.g. brake lines or wiring harnesses.◀

- Remove lines **1** from bracket.
- Remove screws **2**.

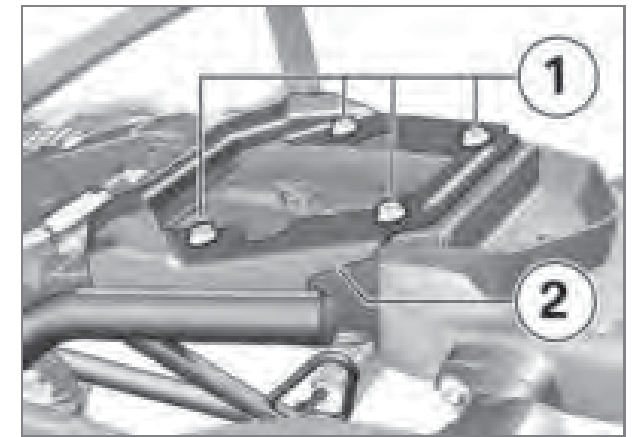

- Remove screws **1** and take off passenger frame **2** toward rear.

Preparing muffler bracket

– with muffler bracket^{OA}

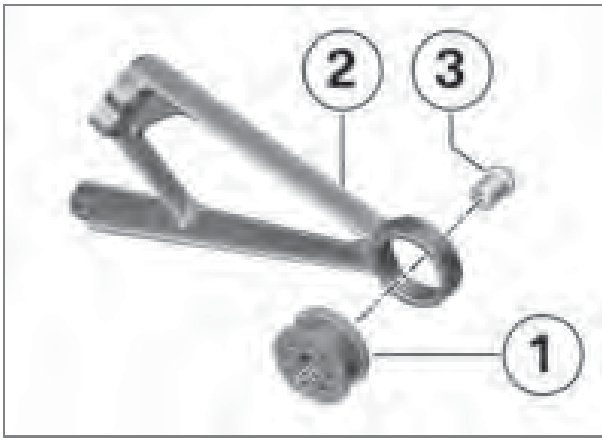

- Fasten rubber decoupler **1** in muffler bracket **2** and install shouldered bushing **3** from right.

Installing muffler bracket

– with muffler bracket^{OA}

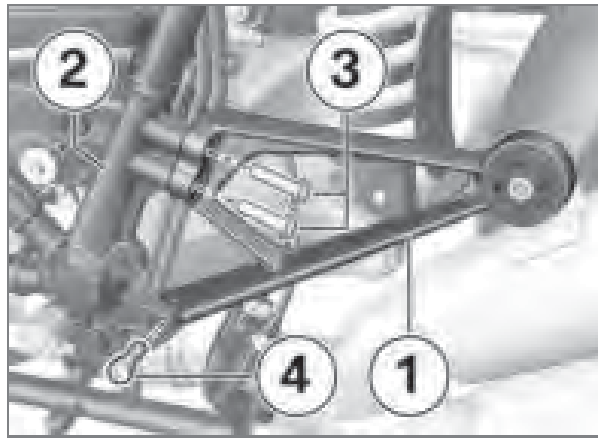

- Lay muffler bracket **1** on rear frame **2**.
- Loosely install screws **3** and **4**.
- Tighten screws **3**.



Passenger frame on rear frame

14 lb/ft (19 Nm)

- Tighten screw **4**.



Bracket for muffler on frame

14 lb/ft (19 Nm)

Mounting muffler

– with muffler bracket^{OA}

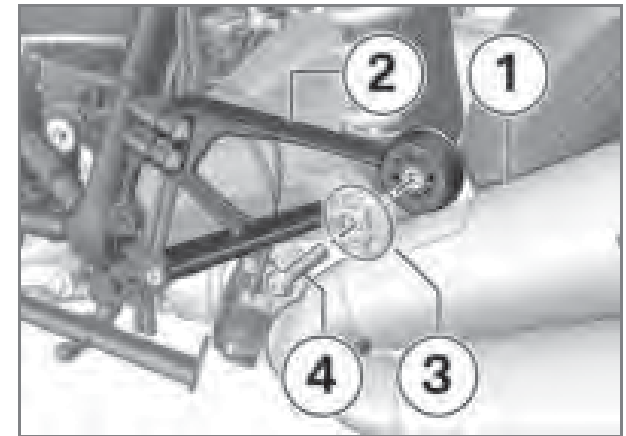

- Align muffler **1** on bracket **2**, lay on washer **3** and install screw **4**.



Muffler on bracket

7 lb/ft (10 Nm)◁

Installing left-hand footrest system

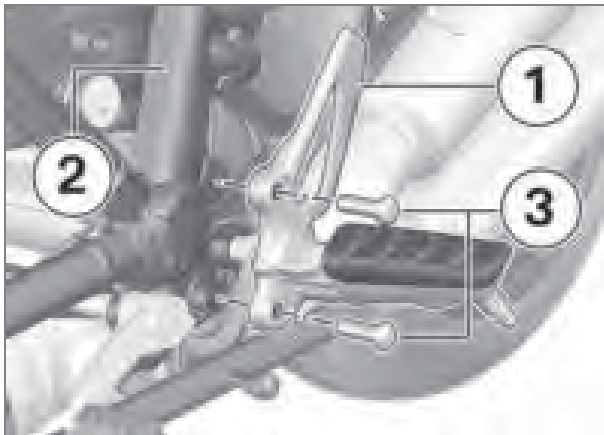

- Lay footrest system **1** on left on rear frame **2** and install screws **3**.



Footrest system on rear frame

14 lb/ft (19 Nm)

Loading correctly without passenger frame

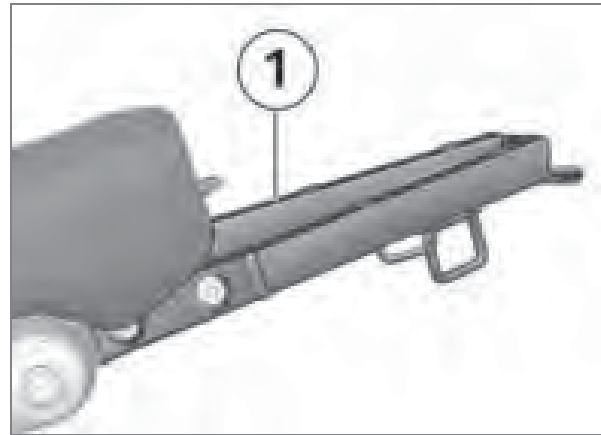

 Overloading and imbalanced loads can adversely affect the motorcycle's handling. Do not exceed the gross weight limit and observe the loading information. ◀

- After the passenger frame is removed, the maximum load in the area of the luggage rack **1** (see figure) must be complied with.



Loading of luggage rack

max 18 lbs (max 8 kg)

Optional accessory



Your authorized BMW Motorrad retailer offers you qualified advise when choosing genuine BMW parts, accessories and other products, e.g. aluminum seat bucket or cover for rear frame). You will find all BMW Motorrad optional accessories on our website: "**www.bmw-motorrad.com**".

Installing passenger frame

Removing left-hand footrest system

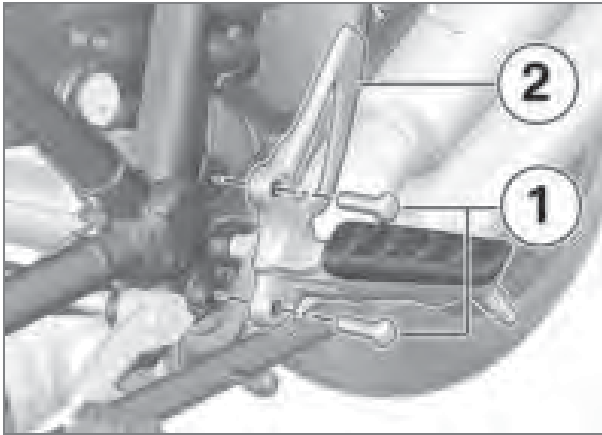

- Remove screws **1** and take off footrest system **2** on left.

Removing muffler

– with muffler bracket^{OA}

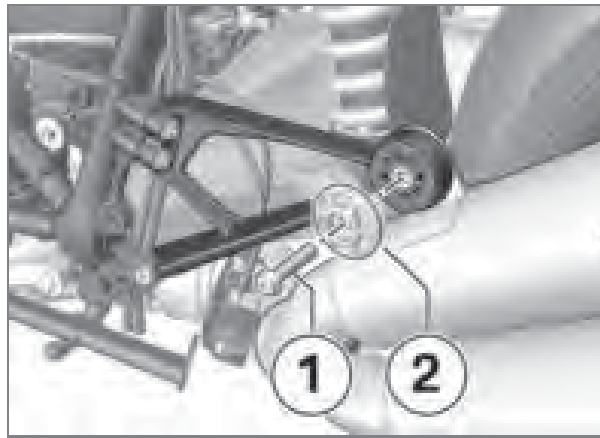

- Remove screw **1** and washer **2**.

Removing end muffler bracket

– with muffler bracket^{OA}

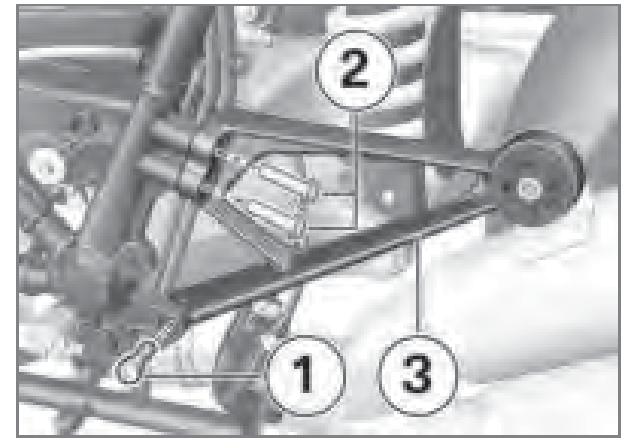

- Remove screws **1** and **2**.
- Take off muffler bracket **3**.

Installing left-hand footrest system

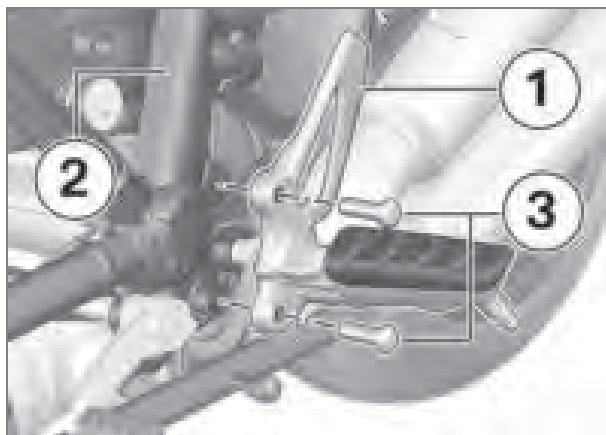

- Lay footrest system **1** on left on rear frame **2** and install screws **3**.

 Footrest system on rear frame

14 lb/ft (19 Nm)

Installing passenger frame

 Paintwork can be scratched and/or damaged.

Use suitable surface or tape off endangered area. ◀

- Remove rider's seat (→ 40).

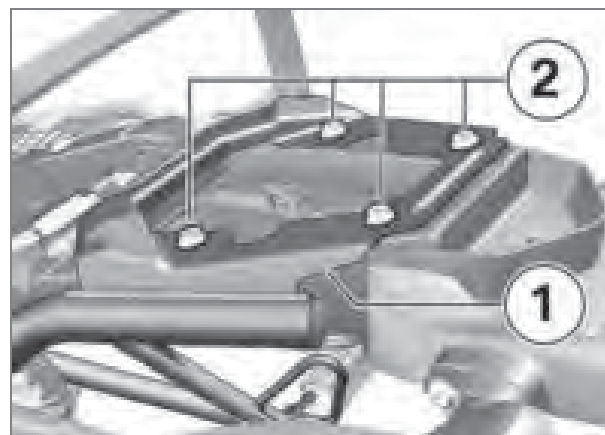

- Mount passenger frame **1** from rear and loosely install screws **2**.

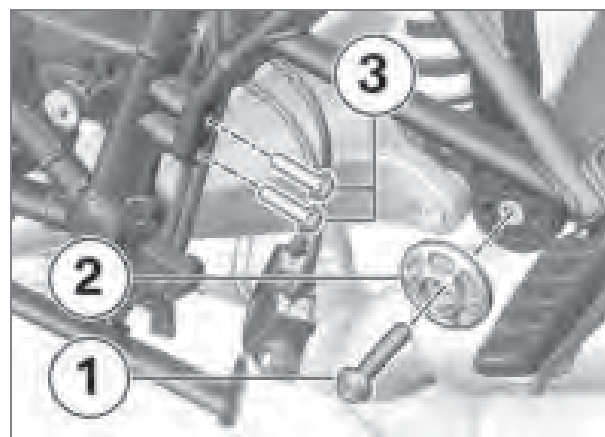

- Loosely install screw **1** and fastening washer **2**.

- Install screws **3**.

 Passenger frame on rear frame

14 lb/ft (19 Nm)

- Tighten screw **1**.

 Muffler on passenger frame

7 lb/ft (10 Nm)

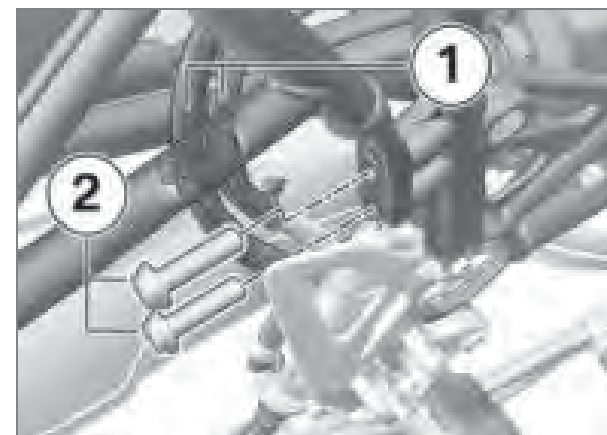

 Components can be damaged.

Do not pinch components, e.g. brake lines or wiring harnesses. ◀

- Fasten lines **1** in bracket **2**.
- Install screws **2**.

 Passenger frame on rear frame
14 lb/ft (19 Nm)

- Install the passenger seat (➡ 41).
- Remove rear wheel stand.

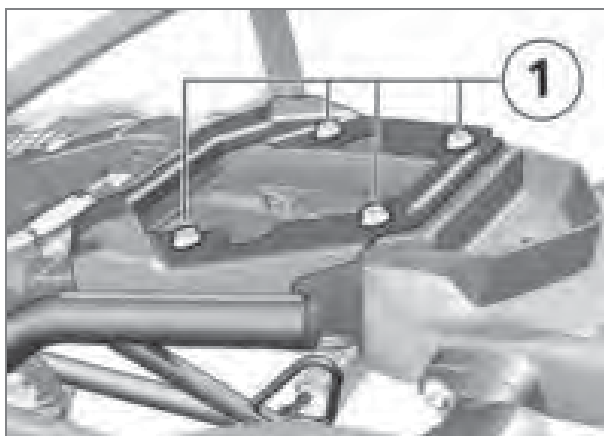

- Tighten screws **1**.

 Passenger frame on luggage rack
6 lb/ft (8 Nm)

- Remove masking.
- Installing driver's seat (➡ 40).

Care

Care products	106
Washing your vehicle	106
Cleaning sensitive vehicle parts	106
Paint care	107
Storing motorcycle.....	108
Protective wax coating	108
Returning motorcycle to use	108

Care products

BMW Motorrad recommends that you use cleaning and care products available at your authorized BMW Motorrad retailer. BMW CareProducts have been materials tested, laboratory tested, and field tested and provide optimum care and protection for the materials used in your vehicle.

 The use of unsuitable cleaning and care products can damage motorcycle components.

For cleaning, do not use any solvents such as nitro-thinners, cold cleaning agents, fuel or similar, and do not use cleaning agents that contain alcohol.◀

Washing your vehicle

BMW Motorrad recommends that you use BMW Insect Remover to soften and wash off insects and stubborn dirt from painted parts before washing the vehicle.

To prevent stains, do not wash the vehicle immediately after it has been exposed to bright sunlight and do not wash it in the sun.

Make sure that the vehicle is washed frequently, especially during the winter months.

To remove road salt, clean the motorcycle with cold water immediately after completion of every trip.

 After washing the motorcycle, after driving through water or in the rain, braking can be delayed owing to damp brake rotors and brake pads.

Brake early until the brake rotors and brake pads are dry.◀

 Warm water intensifies the effect of salt.

Only use cold water to remove road salt.◀

 The high water pressure from high-pressure cleaners (steam blasters) can result in damage to seals, the hydraulic brake system, the electrics and the seat.

Do not use a steam jet or high-pressure cleaning equipment.◀

Cleaning sensitive vehicle parts

Plastics

 If plastic parts are cleaned using unsuitable cleaning agents, the surfaces can be damaged.

Do not use cleaning agents that

contain alcohol, solvents or abrasives to clean plastic parts. 'Insect sponges' or sponges with hard surfaces can also lead to scratches.◀

Fairings and Panels

Clean body panels with water and BMW plastic cleaner.

Headlight glass and plastic lenses

Clean off dirt and insects with a soft sponge and plenty of water.



Soften stubborn dirt and dead insects by covering the affected areas with a wet cloth.◀



Clean with water and sponge only.



Do not use chemical cleaning agents.

Chrome

Especially in the case of road salt, carefully clean chrome parts with plenty of water and BMW auto shampoo. Use chrome polish for additional treatment.

Radiator

Clean the radiator regularly to prevent overheating of the engine due to inadequate cooling. For example, use a garden hose with low water pressure.



Cooling fins can be bent easily.

When cleaning the radiator, ensure that the fins are not bent.◀

Rubber

Treat rubber components with water or BMW rubber protection coating agent.



Using silicone sprays for the care of rubber seals can cause damage.

Do not use silicone sprays or care products that contain silicone.◀

Paint care

Washing the vehicle on a regular basis will help prevent long-term damage from harmful substances, and is especially important when your vehicle is used in areas with high levels of air pollution or where natural contaminants such as tree resin and pollen are present.

At the same time, you should remove particularly aggressive materials immediately; otherwise changes in the paint and discoloration can occur. These include spilled fuel, oil, grease and brake fluid as well as bird droppings. BMW Car Polish and BMW Paint Cleaner are recommended for this procedure.

Contamination on the paint finish is particularly easy to see after

the vehicle has been washed. Remove this type of soiling with cleaning naphtha or spirit on a clean cloth or cotton ball. BMW Motorrad recommends removing tar spots with BMW Tar Remover. Then add a protective wax coating to the paint at these locations.

Storing motorcycle

- Clean the motorcycle.
- Remove battery.
- Spray brake and clutch lever, and side stand pivots with a suitable lubricant.
- Coat bare metal and chrome-plated parts with an acid-free grease (e.g., Vaseline).
- Park motorcycle in a dry room, raising it to remove weight from both wheels.

Protective wax coating

BMW Motorrad recommends applying BMW car wax or products containing carnauba wax or synthetic wax to preserve your paintwork.

When water fails to form beads on the paint surface this indicates it is time to apply wax.

Returning motorcycle to use

- Remove the protective wax coating.
- Clean the motorcycle.
- Install a charged battery.
- Observe checklist before starting.

Technical data

Troubleshooting chart	110	Performance data	123
Threaded fasteners	111	Anti-theft alarm system	123
Engine	113	Remote control	124
Fuel	114		
Engine oil	115		
Clutch	115		
Transmission	116		
Rear-wheel drive	116		
Suspension	117		
Brakes	118		
Wheels and tires	119		
Electrical system	120		
Frame	121		
Dimensions	122		
Weights	122		

Troubleshooting chart

Engine does not start at all or is very difficult to start.

Possible cause	Remedy
Emergency on/off switch (kill switch)	Emergency off switch in normal operating position
Side stand extended and gear engaged	Retract the side stand.
Gear engaged and clutch not disengaged	Select neutral or pull clutch lever
No fuel in tank	Refueling procedure (➡ 60).
Battery drained	Charging connected battery (➡ 92).

Threaded fasteners

Front wheel	Value	Valid
Brake caliper on telescopic forks		
M10 x 65	28 lb/ft (38 Nm)	
Clamping screws (quick-release axle) in axle mount		
M8 x 35	Tighten each screw 3 times diagonally	
	14 lb/ft (19 Nm)	
Quick-release axle in axle mount		
M24 x 1.5	37 lb/ft (50 Nm)	
Rear wheel	Value	Valid
Clip on muffler and exhaust manifold		
M8 x 40 - 10.9	18 lb/ft (25 Nm)	
Muffler on passenger frame		
M8 x 40	7 lb/ft (10 Nm)	

Rear wheel		Value	Valid
Rear wheel on wheel carrier			
M10 x 53 x 1.25	Diagonally		
	44 lb/ft (60 Nm)		
Mirror arm		Value	Valid
Mirror (locknut) on adapter			
Left-hand thread, M10 x 1.25	16 lb/ft (22 Nm)		
Adapter on clamping block			
M10	18 lb/ft (25 Nm)		
Headlight		Value	Valid
Headlight on bracket			
M8 x 40	14 lb/ft (19 Nm)		
Front wheel cover		Value	Valid
Front wheel cover on fork			
M5 x 20	4 lb/ft (5 Nm)		

Engine

Engine number location	On crankcase at lower right, in front of cylinder
Engine type	122EJ
Engine design	Longitudinally mounted two-cylinder opposed-twin engine with two overhead camshafts each, four radially arranged valves per cylinder, air cooling, oil-cooled outlet area and electronic engine management
Displacement	1170 cc (1170 cm ³)
Cylinder bore	4 in (101 mm)
Piston stroke	2.9 in (73 mm)
Compression ratio	12.0:1
Rated output	110 hp (81 kW), at engine speed: 7750 min ⁻¹
Torque	88 lb/ft (119 Nm), at engine speed: 6000 min ⁻¹
Maximum engine speed	max 8500 min ⁻¹
Idle speed	1150 ^{±50} min ⁻¹ , engine at operating temperature

Fuel

Recommended fuel quality	Super Plus unleaded (max. 10 % ethanol, E10) 91 AKI (98 ROZ/RON) 91 AKI
Alternative fuel quality	Super unleaded (minor power restriction and possibly higher consumption) (max. 10 % ethanol, E10) 89 AKI (95 ROZ/RON) 89 AKI
Usable fuel quantity	Approx. 4.8 gal (Approx. 18 l)
Reserve fuel quantity	Approx. 3.2 quarts (Approx. 3 l)
Emission standard	EU 3

BMW recommends BP fuel



Engine oil

Engine oil, capacity	max 1.1 gal (max 4.0 l), with filter replacement
Viscosity class	Product recommended by BMW Motorrad: BMW Motorrad High Performance Oil, SAE 15W-50, API SJ / JASO MA2
Engine oil, quantity for topping up	max 0.5 quarts (max 0.5 l), difference between MIN and MAX

BMW recommends 

Clutch

Clutch design	Single-plate dry clutch
---------------	-------------------------

Transmission

Transmission design	Helical 6-speed transmission with integrated torsional vibration damper, claw shifting via sliding sleeves
Transmission gear ratios	1,737, Primary gear ratio 2,375 (38:16 teeth), 1st gear 1,696 (39:23 teeth), 2nd gear 1,296 (35:27 teeth), 3rd gear 1,065 (33:31 teeth), 4th gear 0,939 (31:33 teeth), 5th gear 0,848 (28:33 teeth), 6th gear

Rear-wheel drive

Type of final drive	Shaft drive with bevel gears
Type of rear suspension	Cast-aluminum single swing arm with BMW Motorrad paralever
Gear ratio of final drive	2.910 (32/11 teeth)

Suspension

Front wheel	
Type of front suspension	Upside-down telescopic forks
Spring travel, front	4.7 in (120 mm), on wheel
Rear wheel	
Type of rear suspension	Cast-aluminum single swing arm with BMW Motorrad paralever
Type of rear suspension	Central spring strut with coil spring, adjustable rebound-stage damping and spring preload
Spring travel at rear wheel	4.7 in (120 mm)
Recommendation on chassis adjustment for one-up operation	Spring preload, turn adjustment wheel counter-clockwise as far as possible Damping, turn adjusting screw as far as possible clockwise, then turn back 1.5 turns
Recommendation on chassis adjustment for two-up operation	Spring preload, turn adjustment wheel clockwise as far as possible Damping, turn adjusting screw as far as possible clockwise, then turn back 1 turn

Brakes

Type of front brake	Hydraulically operated double disc brakes with 4-piston radial monobloc calipers and floating brake discs
Brake-pad material, front	Sintered metal
Front brake-disk thickness	min 0.16 in (min 4 mm), wear limit
Free travel of brake actuation (Front wheel brake)	0.07±0.01 in (1.85±0.25 mm), on piston
Type of rear brake	Hydraulically operated disc brake with 2-piston floating caliper and fixed brake disc
Brake-pad material, rear	Organic
Rear brake-disk thickness	min 0.18 in (min 4.5 mm), wear limit
Free travel of brake actuation (Rear wheel brake)	0.03±0.01 in (0.7±0.2 mm), on piston

Wheels and tires

Recommended tire combinations	You can obtain an overview of the current tire approvals from your authorized BMW Motorrad retailer or on the Internet at www.bmw-motorrad.com
-------------------------------	--

Front wheel

Front wheel design	Spoke wheel with 40 spokes
Front-wheel rim size	3.5" x 17"
Front tire designation	120 / 70 ZR 17
Front wheel load at unladen weight	247 lbs (112 kg)
Permissible front wheel load	max 353 lbs (max 160 kg)
Permissible front-wheel imbalance	max 0.2 oz (max 5 g)

Rear wheel

Rear wheel design	Spoke wheel with 40 spokes
Rear-wheel rim size	5.50" x 17"
Rear tire designation	180 / 55 ZR 17
Rear wheel load at unladen weight	243 lbs (110 kg)
Permissible rear wheel load	max 595 lbs (max 270 kg)

Tire inflation pressures

Tire pressure, front	36.3 psi (2.5 bar), with tire cold
Tire pressure, rear	36.3 psi (2.5 bar), one-up, with cold tires 42.1 psi (2.9 bar), operation with passenger, with cold tires

Electrical system

Electrical rating of onboard socket	5 A
Fuses	Electrical circuits are electronically protected. If an electronic fuse trips and de-energizes a circuit, the circuit is active as soon as the ignition is switched on after the fault has been rectified.

Battery

Battery design	AGM (Absorptive Glass Mat) battery
Battery voltage	12 V
Battery capacity	14 Ah

Spark plugs

Spark plugs, manufacturer and designation	NGK MAR8B-JDS
Electrode gap of spark plug	0.03 in (0.8 mm)

Bulbs

Bulb for low-beam and high-beam headlight	H4 / 12 V / 60/55 W
Bulb for parking light	W5W / 12 V / 5 W
Bulb for taillight/brake light	LED
Bulbs for flashing turn indicators, front	RY10W / 12 V / 10 W
Bulbs for flashing turn indicators, rear	RY10W / 12 V / 10 W

Frame

Frame design	4-piece steel tube frame with supporting drive unit
Location of type plate	Steering head at front left
Location of the vehicle identification number	Rear frame at lower front right

Dimensions

Motorcycle length	82.1 in (2085 mm)
Motorcycle height	49.8 in (1265 mm), in DIN normal-load position; with mirrors
Motorcycle width	35 in (890 mm), with mirrors
Rider's seat height	30.9 in (785 mm), without driver
– with Custom driver's seat ^{OA}	30.5 in (775 mm), without driver
Rider's inside-leg arc, heel to heel	69.3 in (1760 mm), without driver
– with Custom driver's seat ^{OA}	69.1 in (1755 mm), without driver

Weights

Unladen weight	489 lbs (222 kg), DIN unladen weight, ready for road, 90 % full tank of gas, without OE
Permissible gross weight	948 lbs (430 kg)
Maximum payload	459 lbs (208 kg)

Performance data

Top speed	>124 mph (>200 km/h)
Start-off capacity on uphill grades (with permissible total weight)	20 %

Anti-theft alarm system

– with anti-theft alarm^{OE}

Activation time	15 s
Alarm duration	26 s
Activation time between two alarms	12 s
Temperature range	-40...185 °F (-40...85 °C)
Operating voltage	9...16 V

Remote control

– with anti-theft alarm^{OE}

Range of remote control	32.8 ft (10 m)
Readiness for reception of remote control	1 h, after ignition off
Signal frequency	25 kHz, Broadband
Transmission frequency	433.92 MHz
Battery voltage (for remote control)	3 V
Battery type (for remote control)	CR 2032 lithium

Service

Reporting safety defects	126
BMW Motorrad Service	127
BMW Motorrad Mobility Services	127
Maintenance procedures	127
Confirmation of maintenance work	129
Confirmation of service	134

Reporting safety defects

If you believe that your vehicle has a defect which could cause a crash or could cause injury or death, you should immediately inform the National Highway Traffic Safety Administration (NHTSA) in addition to notifying BMW of North America, LLC.

If NHTSA receives similar complaints, it may open an investigation, and if it finds that a safety defect exists in a group of vehicles, it may order a recall and remedy campaign. However, NHTSA cannot become involved in individual problems between you, your retailer, or BMW of North America, LLC.

To contact NHTSA, you may call the Vehicle Safety Hotline toll-free at 1-888-327-4236 (TTY: 1-800-424-9153); go to <http://www.safercar.gov>; or write to: Administrator, NHTSA, 400 Seventh Street, SW., Washington, DC 20590. You can also obtain other information about motor vehicle safety from <http://www.safercar.gov>.

BMW Motorrad Service

With its worldwide dealer network, BMW Motorrad can attend to you and your motorcycle in over 100 countries around the globe. BMW Motorrad retailers have the technical information and expertise needed to conduct reliable service and repairs covering every aspect of your BMW. You can find the nearest authorized BMW Motorrad retailer by visiting our Internet site at "www.bmw-motorrad.com".



If this maintenance and repair work is performed inexpertly, there is a danger of damage and associated safety risks. BMW Motorrad recommends having corresponding work on your motorcycle carried out by a specialized workshop, preferably by an authorized BMW Motorrad retailer. ◀

To ensure that your BMW consistently remains in optimal condition BMW Motorrad urges you to observe the recommended service intervals.

Have all maintenance and repair work confirmed in the "Service" chapter in this manual. For generous treatment of claims submitted after the warranty period has expired (goodwill), evidence of regular maintenance is essential.

You can obtain information on the contents of the BMW Services from your BMW Motorrad retailer.

BMW Motorrad Mobility Services

The BMW Motorrad Mobility Services furnish you and your new BMW motorcycle with extra security by offering a wide array of assistance services in the event

of a breakdown (mobile service, breakdown assistance, vehicle recovery and retrieval, etc.).

Contact your authorized BMW Motorrad retailer for additional information on available mobility-maintenance services.

Maintenance procedures

BMW Pre-Delivery Check

The BMW pre-delivery check is carried out by your authorized BMW Motorrad retailer before it turns over the vehicle to you.

BMW Running-in Check

The BMW running-in check must be carried out between 300 mls and 750 mls (500 km and 1200 km).

BMW Service

BMW Service is carried out once a year. The scope of the services performed may be dependent on the vehicle owner and the mileage driven. Your BMW Motorrad retailer confirms that the service has been performed and enters the date for the next service.

For riders who drive long distances annually, it may be necessary to come in for service before the entered date. In this case a corresponding maximum odometer reading will also be entered in the confirmation of service. If this odometer reading is reached before the next service date, service must be performed sooner.

The service display in the multi-function display reminds you of the next service date approx. one month or 620 miles (1000 km) before the entered values.

Confirmation of maintenance work

BMW Pre-Delivery Check

Conducted

on _____

Stamp, Signature

BMW Running-in Check

Conducted

on _____

Odometer reading _____

Next service
at the latest

on _____

or, if reached sooner,

Odometer reading _____

Stamp, Signature

BMW Service

Conducted

on _____

Odometer reading _____

Next service

at the latest

on _____

or, if reached sooner,

Odometer reading _____

Stamp, Signature

BMW Service

Conducted

on _____

Odometer reading _____

Next service

at the latest

on _____

or, if reached sooner,

Odometer reading _____

Stamp, Signature

BMW Service

Conducted

on _____

Odometer reading _____

Next service

at the latest

on _____

or, if reached sooner,

Odometer reading _____

Stamp, Signature

BMW Service

Conducted

on _____

Odometer reading _____

Next service
at the latest

on _____

or, if reached sooner,

Odometer reading _____

Stamp, Signature

BMW Service

Conducted

on _____

Odometer reading _____

Next service
at the latest

on _____

or, if reached sooner,

Odometer reading _____

Stamp, Signature

BMW Service

Conducted

on _____

Odometer reading _____

Next service
at the latest

on _____

or, if reached sooner,

Odometer reading _____

Stamp, Signature

BMW Service

Conducted

on _____

Odometer reading _____

Next service

at the latest

on _____

or, if reached sooner,

Odometer reading _____

Stamp, Signature

BMW Service

Conducted

on _____

Odometer reading _____

Next service

at the latest

on _____

or, if reached sooner,

Odometer reading _____

Stamp, Signature

BMW Service

Conducted

on _____

Odometer reading _____

Next service

at the latest

on _____

or, if reached sooner,

Odometer reading _____

Stamp, Signature

BMW Service

Conducted

on _____

Odometer reading _____

Next service
at the latest

on _____

or, if reached sooner,

Odometer reading _____

Stamp, Signature

BMW Service

Conducted

on _____

Odometer reading _____

Next service
at the latest

on _____

or, if reached sooner,

Odometer reading _____

Stamp, Signature

BMW Service

Conducted

on _____

Odometer reading _____

Next service
at the latest

on _____

or, if reached sooner,

Odometer reading _____

Stamp, Signature

Confirmation of service

The table is intended as proof of maintenance and repair work, the installed optional accessories and any special campaign (recall) work carried out.

Work carried out	Odometer reading	Date

Work carried out	Odometer reading	Date

- A**
Abbreviations and symbols, 6
ABS
 Self-diagnosis, 57
 Technology in detail, 64
 Warning lamps, 27
Accessories
 General instructions, 96
Alarm
 triggering, 46
Alarm function
 Activate motion sensor, 45
 Deactivating, 47
Average values
 Resetting, 32
- B**
Battery
 change, 51
 Charging connected battery, 92
 Charging disconnected battery, 93
 Maintenance instructions, 91
 Position on vehicle, 16
 Replacing battery, 93
 Technical data, 120
 Warning for battery charge current, 26
Brake fluid
 Checking fluid level at rear, 76
 Checking front fluid level, 75
 Front reservoir, 13
 Rear reservoir, 13
Brake pads
 Checking front, 73
 Checking rear, 74
 Running in, 58
Brakes
 Adjusting handlebar lever, 36
 Checking operation, 72
 Safety instructions, 58
 Technical data, 118
 Wear indicator, 74
Breaking in, 57
Bulbs
 Replacing bulb for front and rear turn indicator, 89
 Replacing bulb for parking light, 88
 Replacing bulbs for dipped and main-beam headlights, 87
 Replacing LED tail light, 90
 Technical data, 121
 Warning indicator for defective bulb, 26
- C**
Checklist, 55
Clock
 Adjusting, 31
 Control, 17
Clutch
 Adjusting handlebar lever, 35
 Checking operation, 77
 Fluid reservoir, 11
 Technical data, 115
Confirmation of maintenance work, 129
- D**
Damping
 Adjusting, 38
Deactivating
 Alarm, 47
 Motion sensor, 46

Dimensions
Technical data, 122

DWA
Indicator lamp, 17
Warning indicator, 26

E

Electrical system
Technical data, 120
Emergency on/off switch (kill switch), 15
Operating, 35
Engine
Engine-electronics warning indicator, 25
Starting, 56
Technical data, 113

Engine oil
Checking level, 71
Fill location, 13
Fluid level indicator, 11
Technical data, 115
Topping up, 72

Equipment, 7

F

Factory settings, 48
Frame
Technical data, 121
Front wheel stand
Mounting, 68
Fuel
Filler neck, 11
Refueling procedure, 60
Reserve quantity, 22
Technical data, 114
Fuel reserve
Warning indicator, 25
Fuses
Technical data, 120

H

Hazard warning flashers
Control, 14
Operating, 34
Headlight
Adjusting for RHD/LHD traffic, 39
Headlamp range, 40
Removing and installing, 86

Heated handlebar grips
Operating, 36
Horn, 14

I

Ignition
Switching off, 30
Switching on, 30
Immobilizer
Spare key, 31
Warning indicator, 25
Indicator lights, 17
Overview, 20
Instrument cluster
Ambient light sensor, 17
Overview, 17

J

Jump-starting, 90

K

Keys, 30

L

Lights
Control, 14
Low-beam headlight, 33

- Operating headlight flasher, 33
- Operating high-beam headlight, 33
- Operating parking light, 33
- Parking lamps, 33

- logon
 - Remote control, 50

M

- Maintenance
 - General instructions, 68
- Maintenance intervals, 127
- Mirrors
 - Adjusting, 37
- Mobility Services, 127
- Motion sensor
 - Deactivating, 46
- Motorcycle
 - Care, 105
 - Cleaning, 105
 - Lashing down, 61
 - Parking, 59
 - Returning to use, 108
 - Storage, 108

- Multifunction display, 17
 - Control, 14
 - Meaning of symbols, 22
 - Overview, 21
 - Selecting display readings, 32
- Multifunction switch
 - General view, left , 14
 - General view, right, 15

N

- Notice concerning current status, 7

O

- Odometer
 - Control, 17
 - Resetting, 32
- Onboard power socket
 - Information on use, 96
 - Position on vehicle, 11
- Onboard tool kit
 - Contents, 68
 - Position on vehicle, 16
- Overview of warning indicators, 24

Overviews

- Instrument cluster, 17
- Left handlebar fitting, 14
- Left side of vehicle, 11
- Multifunction display, 21
- Right handlebar fitting, 15
- Right side of vehicle, 13
- Underneath seat, 16
- Warning and indicator lamps, 20

P

- Passenger frame
 - Installing, 101, 102
 - Removing, 97
- Passenger seat
 - Installing, 40
 - Locking mechanism, 13
 - Removing, 40
- Payload table
 - Label, 16
- Pre-Ride-Check, 56
- Programming, 48

R

- Rear-wheel drive
 - Technical data, 116
- Rear-wheel stand
 - Mounting, 70
- Refueling, 60
- Remote control
 - logon, 50
 - synchronize, 51
- Rider's Manual (US Model)
 - Position on vehicle, 16
- Rider's seat
 - Installing, 40
 - Removing, 40

S

- Safety instructions
 - on Brakes, 58
 - On riding, 54
- Service, 127
 - Reporting safety defects, 126
- Spark plugs
 - Technical data, 120
- Speedometer, 17

- Spring preload
 - Adjusting, 38
 - Rear adjuster, 13
- Starting, 56
 - Control, 15
- Steering lock, 30
- Suspension
 - Technical data, 117
- Switching off, 59
- Symbols
 - Meaning, 22

T

- Tachometer, 17
- Technical data
 - Battery, 120
 - Brakes, 118
 - Bulbs, 121
 - Clutch, 115
 - Dimensions, 122
 - Electrical system, 120
 - Engine, 113
 - Engine oil, 115
 - Frame, 121
 - Fuel, 114

- Rear-wheel drive, 116
- Spark plugs, 120
- Standards, 7
- Suspension, 117
- Transmission, 116
- Weights, 122
- Wheels and tires, 119
- Tire inflation pressures
 - Label, 16
- Tires
 - Checking tire inflation pressures, 39
 - Checking tread depth, 77
 - Inflation pressures, 120
 - Recommendation, 77
 - Running in, 58
 - Technical data, 119
- Torques, 111
- Transmission
 - Technical data, 116
- Troubleshooting chart, 110
- Turn indicators
 - Operating, 33
 - Operating element, left, 14

Type plate
Position on vehicle, 11

V

Vehicle identification number
Position on vehicle, 13

W

Warning lamps, 17
ABS, 27
Anti-theft alarm system, 26
Battery charge current, 26
Bulb defective, 26
Display, 23
Engine electronics, 25
Fuel reserve, 25
Immobilizer, 25
Overview, 20

Weights
Technical data, 122

Wheels
Check wheel rims, 77
Checking spokes, 77
Install front wheel, 81
Installing rear wheel, 84
Remove front wheel, 78

Remove rear wheel, 83
Size change, 78
Technical data, 119

The descriptions and illustrations in this manual may vary from your own motorcycle's actual equipment, depending upon its equipment level and accessories as well as your specific national version. No claims stemming from these differences can be recognized.

Dimensions, weights, fuel consumption and performance data are quoted to the customary tolerances.

The right to modify designs, equipment and accessories is reserved.

Errors and omissions excepted.

© 2013 Bayerische Motoren
Werke Aktiengesellschaft
80788 Munich, Germany

Reprints and duplication of this work, in whole or part, are prohibited without the express written approval of BMW Motorrad, Aftersales.

Original Rider's Manual, printed in Germany.

Important data for refueling:

Fuel	
Recommended fuel quality	Super Plus unleaded (max. 10 % ethanol, E10) 91 AKI (98 ROZ/RON) 91 AKI
Alternative fuel quality	Super unleaded (minor power restriction and possibly higher consumption) (max. 10 % ethanol, E10) 89 AKI (95 ROZ/RON) 89 AKI
Usable fuel quantity	Approx. 4.8 gal (Approx. 18 l)
Reserve fuel quantity	Approx. 3.2 quarts (Approx. 3 l)
Tire inflation pressures	
Tire pressure, front	36.3 psi (2.5 bar), with tire cold
Tire pressure, rear	36.3 psi (2.5 bar), one-up, with cold tires 42.1 psi (2.9 bar), operation with passenger, with cold tires

BMW recommends 

Order No.: 01 41 8 550 817
07.2013, 1st edition, 07

