Honda CRF80F

OWNER'S MANUAL

MANUAL DEL PROPIETARIO

© Honda Motor Co., Ltd. 2008

IMPORTANT INFORMATION

- **OPERATOR ONLY. NO PASSENGER**

This motorcycle is designed and constructed as an operator-only model. The seating configuration does not safely permit the carrying of a passenger. Do not exceed the maximum weight capacity.

- **FOR OFF-ROAD USE ONLY**

This motorcycle is designed and manufactured for off-road use only.

- **PARENTS : READ IMPORTANT MESSAGE ON PAGE 1 .**

- **READ THIS OWNER'S MANUAL CAREFULLY**

Pay special attention to the safety messages that appear throughout the manual. These messages are fully explained in the "A Few Words About Safety" section which appears before the Contents page.

This manual should be considered a permanent part of the motorcycle and should remain with the motorcycle when resold.

Honda CRF80F OWNER'S MANUAL

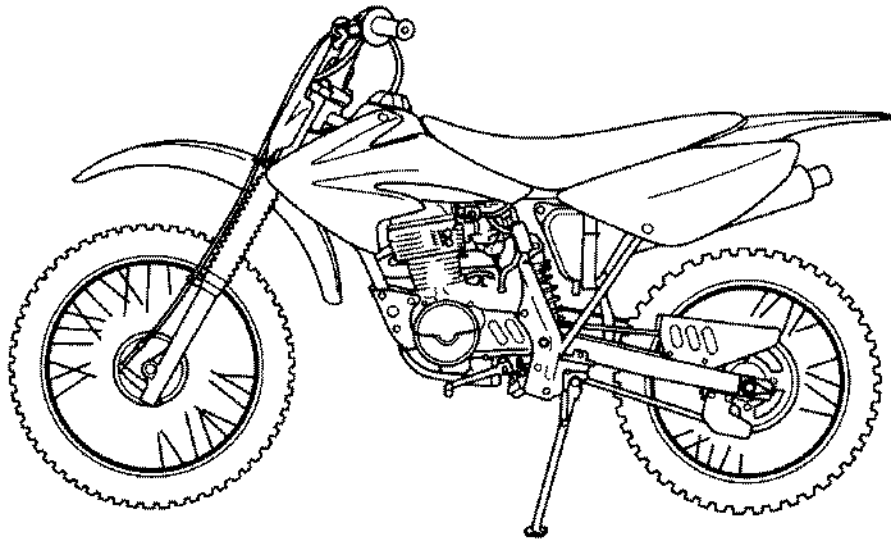

All information in this publication is based on the latest production information available at the time of approval for printing. Honda Motor Co.,Ltd. reserves the right to make changes at any time without notice and without incurring any obligation.

No part of this publication may be reproduced without written permission.

WELCOME

Your new motorcycle presents you with an invitation to adventure and a challenge to master the machine. Your safety depends not only on your own alertness and familiarity with the motorcycle, but also the motorcycle's mechanical condition. A pre-ride inspection before every outing and regular maintenance are essential.

To help meet the challenges safely and enjoy the adventure fully, become thoroughly familiar with this Owner's Manual **BEFORE YOU RIDE THE MOTORCYCLE**.

As you read this manual, you will find information that is preceded by a **NOTICE** symbol. This information is intended to help you avoid damage to your motorcycle, other property, or the environment.

When service is required, remember that your Honda dealer knows your motorcycle best. If you have the required mechanical "know-how" and tools, your dealer can supply you with an official Honda Shop Manual to help you perform many maintenance and repair tasks.

Pleasant riding, and thank you for choosing a Honda !

-
- The following codes in this manual indicate each country.

U	Australia	New Zealand
MX	Mexico	

- The specifications may vary with each locale.

A FEW WORDS ABOUT SAFETY

Your safety, and the safety of others, is very important. And operating this motorcycle safely is an important responsibility.

To help you make informed decisions about safety, we have provided operating procedures and other information on labels and in this manual. This information alerts you to potential hazards that could hurt you or others.

Of course, it is not practical or possible to warn you about all hazards associated with operating or maintaining a motorcycle. You must use your own good judgment.

You will find important safety information in a variety of forms, including:

- **Safety Labels** — on the motorcycle.
- **Safety Messages** — preceded by a safety alert symbol  and one of three signal words: **DANGER, WARNING, or CAUTION.**

These signal words mean:

▲ DANGER

You **WILL** be **KILLED** or **SERIOUSLY HURT** if you don't follow instructions.

▲ WARNING

You **CAN** be **KILLED** or **SERIOUSLY HURT** if you don't follow instructions.

▲ CAUTION

You **CAN** be **HURT** if you don't follow instructions.

- **Safety Headings** — such as Important Safety Reminders or Important Safety Precautions.
- **Safety Section** — such as Motorcycle Safety.
- **Instructions** — how to use this motorcycle correctly and safely.

This entire manual is filled with important safety information — please read it carefully.

OPERATION

page

- 1 MOTORCYCLE SAFETY**
- 1 IMPORTANT MESSAGE TO PARENTS
- 3 IMPORTANT SAFETY INFORMATION
- 5 PROTECTIVE APPAREL
- 7 LOAD LIMITS AND GUIDELINES

11 PARTS LOCATION

14 MAJOR COMPONENTS

(Information you need to operate this motorcycle)

- 14 BRAKES
- 19 CLUTCH
- 22 FUEL
- 26 ENGINE OIL
- 27 TYRES

page

- 32 ESSENTIAL INDIVIDUAL COMPONENTS**
- 32 IGNITION SWITCH
- 33 ENGINE STOP BUTTON

page
34 FEATURES
(Not required for operation)
34 SIDE COVER

page
35 OPERATION
35 PRE-RIDE INSPECTION
37 STARTING THE ENGINE
40 RUNNING-IN
41 RIDING
43 HIGH ALTITUDE RIDING
(Except Mexico)
43 LOW ALTITUDE RIDING
(Mexico only)
44 BRAKING
45 PARKING
45 ANTI-THEFT TIPS

MAINTENANCE

page

46	MAINTENANCE
46	THE IMPORTANCE OF MAINTENANCE
47	MAINTENANCE SAFETY
48	SAFETY PRECAUTIONS
49	MAINTENANCE SCHEDULE
52	TOOL KIT
53	SERIAL NUMBERS
54	COLOUR LABEL
55	AIR CLEANER
56	ENGINE OIL
61	SPARK PLUG
63	IDLE SPEED
64	THROTTLE OPERATION
66	SPARK ARRESTER
67	DRIVE CHAIN
72	WHEEL RIMS AND SPOKES
73	WHEEL REMOVAL
76	BRAKE SHOE WEAR
77	FRONT SUSPENSION
78	REAR SUSPENSION
79	SIDE STAND

page

80	CLEANING
83	STORAGE GUIDE
83	STORAGE
85	REMOVAL FROM STORAGE
86	TAKING CARE OF THE UNEXPECTED
87	SPECIFICATIONS

MOTORCYCLE SAFETY

IMPORTANT MESSAGE TO PARENTS

Your child's safety is very important to Honda. That's why we urge you to read this message before you let any young person ride this motorcycle. Off-road riding can be fun. But as with riding a bicycle, bad judgements can result in injuries, and we don't want that to happen! As a parent, you can help prevent accidents by making good decisions about if, when, and how your youngster rides this motorcycle.

Riding Readiness

The first decision you'll need to make is whether your youngster is ready to ride. Riding readiness varies widely from one person to another, and age and size are not the only factors.

PHYSICAL ABILITY is an important consideration. For example, riders must be big enough to hold the motorcycle up, get on, and comfortably sit on the seat with both feet touching the ground. They should also be able to easily reach and work the brakes, the throttle and all other controls.

ATHLETIC ABILITY is necessary for riding a motorcycle. Generally speaking, your youngster should be good at riding a bicycle before getting on a motorcycle. Can your youngster judge speeds and distances on a bicycle and react with proper hand and foot actions? Anyone who does not have good coordination, balance, and agility is not ready to ride this motorcycle.

MENTAL AND EMOTIONAL MATURITY are requirements for safe riding. Does your youngster think through problems and come to logical solutions? On a bicycle, does your youngster obey safe riding rules? Be honest! Young people who take unnecessary risks, make bad judgements and don't obey rules are not ready to ride this motorcycle.

Instruction and Supervision

If you decide that your youngster is ready to safely operate this motorcycle, make sure both of you carefully read and understand the Owner's Manual before riding. Also be sure that your youngster has a helmet and other appropriate riding equipment and always wears it when operating the vehicle or sitting on it.

GOOD INSTRUCTION is an important part of hands-on training. The teacher can either be you or another responsible adult who has experience with off-road motorcycle riding. (For help in finding a qualified instructor, talk with your Honda dealer.) Even if you're not the main teacher, it's up to you to ensure your youngster's safety. Remember, learning to ride a motorcycle is a gradual step-by-step process. It takes time, patience and practice — many hours over a period of weeks or months.

SUPERVISION is another important obligation of parents. Even after youngsters have become skilled off-road riders, they should always ride with adult supervision. It helps to regularly remind young riders of basic safety rules and cautions. And remember, it's your responsibility to see that the vehicle is properly maintained and kept in safe operating condition.

SAFE AND RESPONSIBLE RIDING must be an ongoing commitment—by you and your youngster. When you both put safety first, you can enjoy more peace of mind, and your youngster can enjoy more hours of safe off-road riding.

For your convenience, this CRF80F comes with an ignition switch and key. Remove the key when the motorcycle is parked to help prevent unauthorized use.

IMPORTANT SAFETY INFORMATION

Your motorcycle can provide many years of service and pleasure—if you take responsibility for your own safety and understand the challenges you can meet while riding.

This motorcycle has been designed for younger riders, as well as for smaller adults. However, not all youngsters are physically or emotionally ready to ride. Therefore, before parents allow any youngster to ride this motorcycle, we urge them to carefully read the Important Message to Parents on page 1 .

There is much that you can do to protect yourself when you ride. You'll find many helpful recommendations throughout this manual. Following are a few that we consider to be most important.

Always Wear a Helmet

It's a proven fact: helmets significantly reduce the number and severity of head injuries. So always wear an approved motorcycle helmet. We also recommend that you wear eye protection, sturdy boots, gloves and other protective gear (page 5).

Never Carry a Passenger

Your motorcycle is designed for one person only. There are no handholds, footrests, or seat for a second person—so never carry a passenger. A passenger could interfere with your ability to move around to maintain your balance and control of the motorcycle.

Ride Off-Road Only

Your motorcycle is designed and manufactured for off-road use only. The tyres are not made for pavement, and the motorcycle does not have turn signals and other features required for use on public roads. If you need to cross a paved or public road, get off and walk your motorcycle across.

Take Time to Learn and Practice

Developing off-road riding skills is a gradual, step-by-step process. Start by practicing at low speeds in a safe area and slowly build your skills. Personal instruction from an experienced rider can also be valuable.

If you need assistance, ask your dealer about riding groups in your area.

Be Alert for Off-Road Hazards

The terrain can present a variety of challenges when you ride off-road. Continually “read” the terrain for unexpected turns, drop-offs, rocks, ruts, and other hazards. Always keep your speed low enough to allow time to see and react to hazards.

Ride Within Your Limits

Pushing the limits is another major cause of motorcycle accidents. Never ride beyond your personal abilities or faster than conditions warrant. Remember that alcohol, drugs, fatigue and inattention can significantly reduce your ability to make good judgements and ride safely.

Don't Drink and Ride

Alcohol and riding don't mix. Even one drink can reduce your ability to respond to changing conditions, and your reaction time gets worse with every additional drink. So don't drink and ride, and don't let your friends drink and ride either.

Keep Your Bike in Safe Condition

For safe riding, it's important to inspect your motorcycle before every ride and perform all recommended maintenance. Never exceed load limits, and only use accessories that have been approved by Honda for this motorcycle. See page 7 for more details.

Others

- This motorcycle is not equipped with lights. Don't ride at night.

PROTECTIVE APPAREL

For your safety, we strongly recommend that you always wear an approved motorcycle helmet, eye protection, boots, gloves, long pants, and a long-sleeved jersey, shirt or jacket whenever you ride. Although complete protection is not possible, wearing proper gear can reduce the chance of injury when you ride.

Following are suggestions to help you choose proper gear.

⚠ WARNING

Not wearing a helmet increases the chance of serious injury or death in a crash.

Be sure you always wear a helmet, eye protection and other protective apparel when you ride.

Helmets and Eye Protection

Your helmet is your most important piece of riding gear because it offers the best protection against head injuries. A helmet should fit your head comfortably and have a chin strap that can be tightened securely.

An open-face helmet offers some protection, but a full-face helmet offers more. Always wear a face shield or goggles to protect your eyes and help your vision.

Additional Riding Gear

In addition to a helmet and eye protection, we also recommend:

- Sturdy off-road motorcycle boots to help protect your feet, ankles, and lower legs.
- Off-road motorcycle gloves to help protect your hands.
- Riding pants with knee and hip pads, a riding jersey with padded elbows, and a chest/shoulder protector.

LOAD LIMITS AND GUIDELINES

Your Honda was designed as a rider-only motorcycle. It was not designed to carry a passenger or cargo. A passenger or cargo could interfere with your ability to move around to maintain your balance and control of the motorcycle.

In addition, exceeding the weight limits or carrying an unbalanced load can seriously affect your motorcycle's handling, braking, and stability. Adding accessories or making modifications that change this motorcycle's design and performance can also make it unsafe. Also, the weight of any accessories will reduce the maximum load the motorcycle can carry.

The following pages give more specific information on loading, accessories and modifications.

Loading

How much weight you put on your motorcycle, and how you load it, are important to your safety. If you decide to carry cargo, you should be aware of the following information.

⚠ WARNING

Overloading or carrying a passenger can cause a crash and you can be seriously hurt or killed.

Follow all load limits and other loading guidelines in this manual.

Load Limits

Following are the load limits for your motorcycle:

Maximum weight capacity:

100 kg (220 lbs)

Includes the weight of the rider and any accessories

Loading Guidelines

As discussed on page 7 , we recommend that you do not carry any cargo on this motorcycle. However, if you decide to carry cargo, ride at reduced speeds and follow these common-sense guidelines:

- Keep cargo small and light. Make sure it cannot easily be caught on brush or other objects, and that it does not interfere with your ability to shift position to maintain balance and stability.

- Place weight as close to the center of the motorcycle as possible.
- Do not attach large or heavy items (such as a sleeping bag or tent) to the handlebar, fork, or front fender.
- Make sure that all cargo is tied down securely.
- Never exceed the maximum weight limit.
- Check that both tyres are properly inflated (page 27).

Accessories and Modifications

Modifying your motorcycle or using non-Honda accessories can make your motorcycle unsafe. Before you consider making any modifications or adding an accessory, be sure to read the following information.

⚠ WARNING

Improper accessories or modifications can cause a crash in which you can be seriously hurt or killed.

Follow all instructions in this owner's manual regarding accessories and modifications.

Accessories

We strongly recommend that you use only Honda Genuine Accessories that have been specifically designed and tested for your motorcycle. Because Honda cannot test all other accessories, you must be personally responsible for proper selection, installation and use of non-Honda accessories. Check with your dealer for assistance and always follow these guidelines:

- Make sure the accessory does not reduce ground clearance and lean angle, limit suspension travel or steering travel, alter your riding position or interfere with operating any controls.

Modifications

We strongly advise you not to remove any original equipment or modify your motorcycle in any way that would change its design or operation. Such changes could seriously impair your motorcycle's handling, stability and braking, making it unsafe to ride.

Removing or modifying your exhaust system (such as the spark arresters or mufflers) or other equipment can also make your motorcycle illegal.

PARTS LOCATION

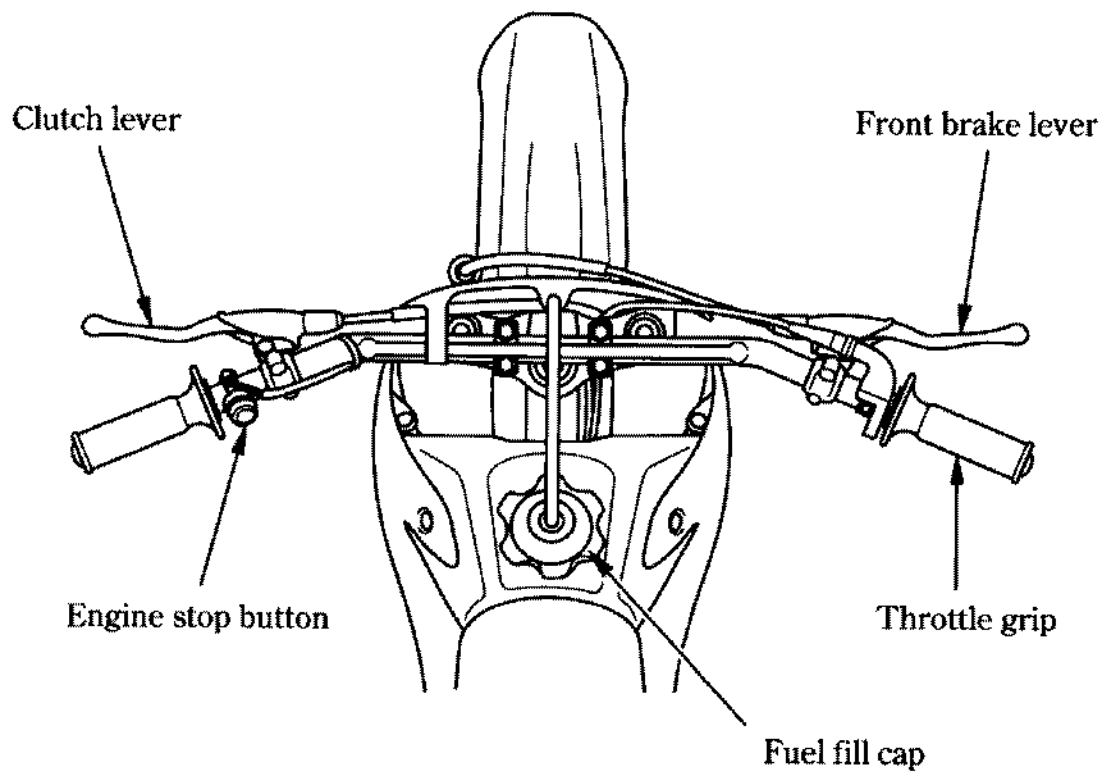

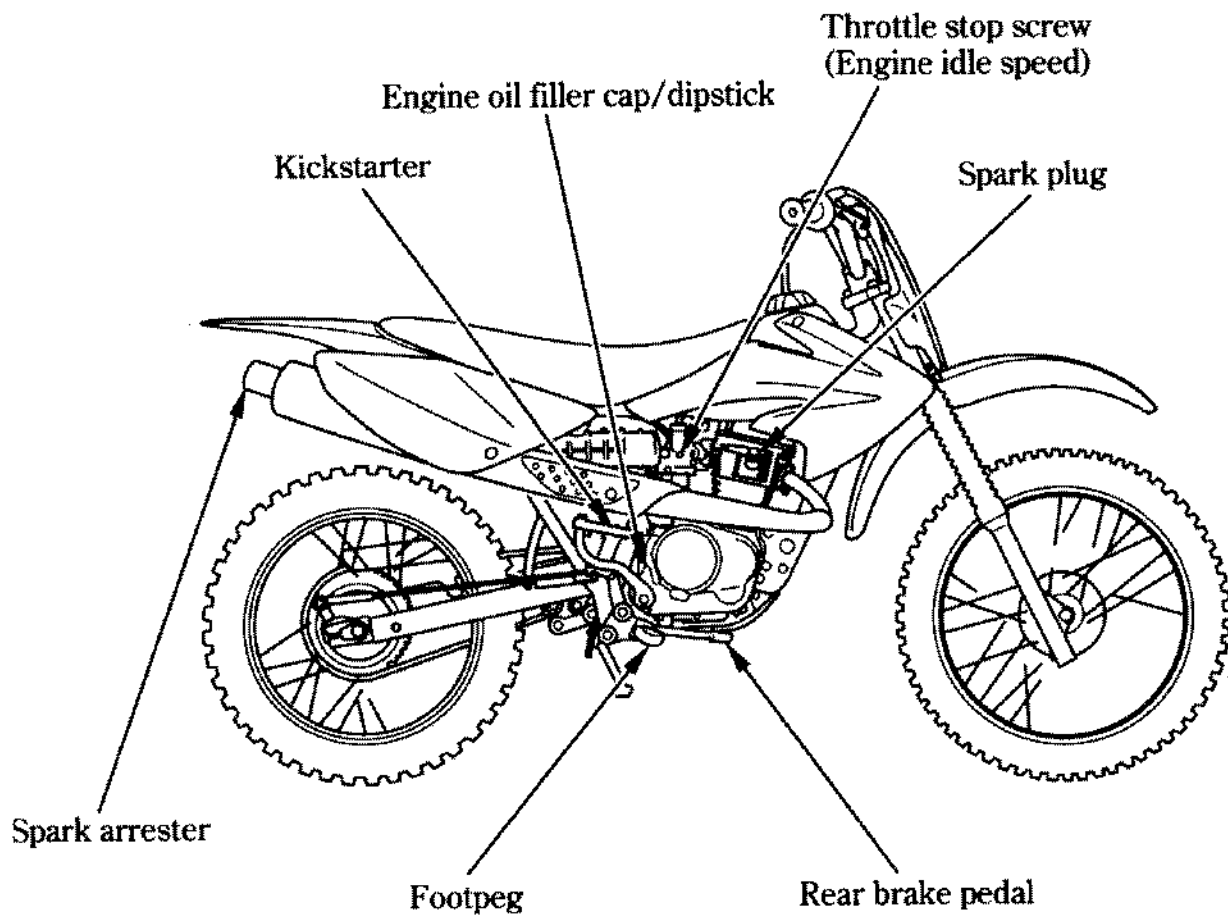

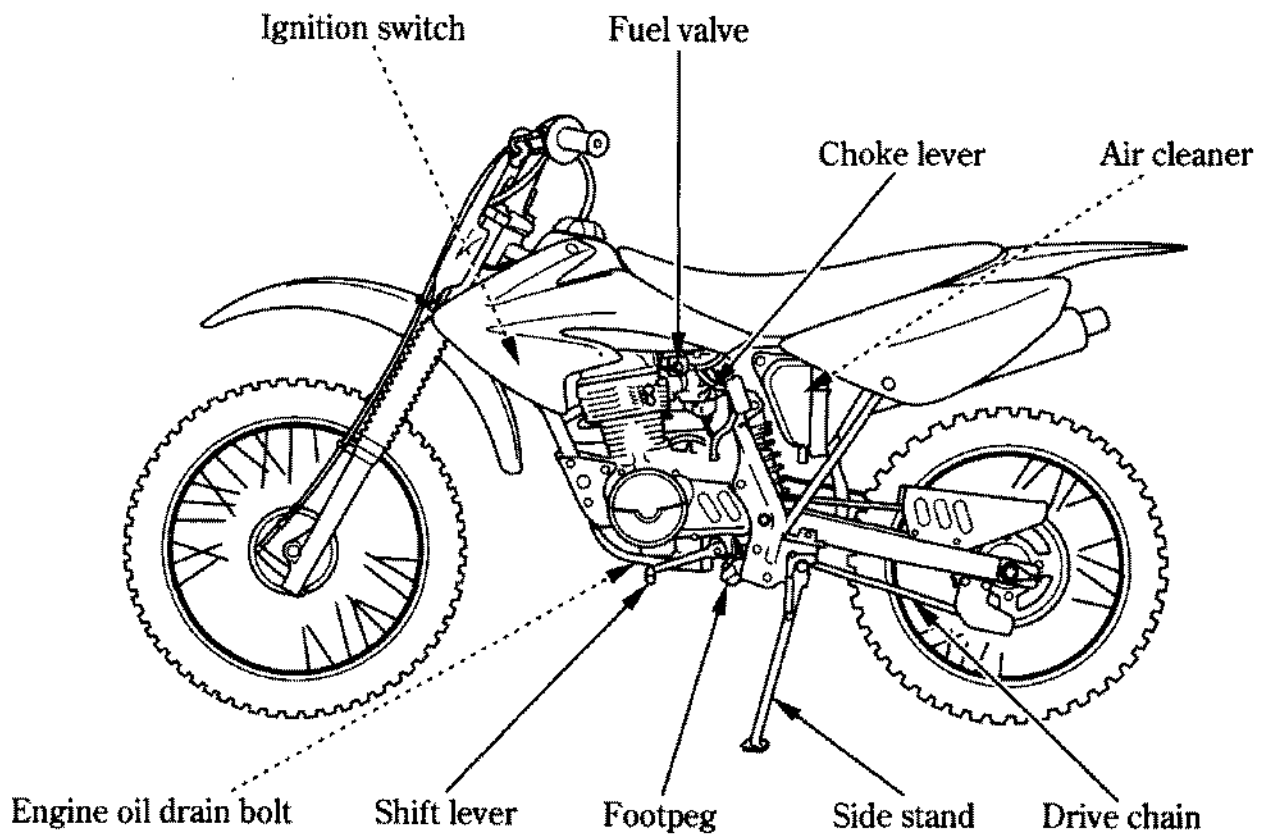

MAJOR COMPONENTS

(Information you need to operate this motorcycle)

BRAKES

Front Brake

Brakes are items of personal safety and should always be maintained in proper adjustment.

The distance the front brake lever or rear brake pedal moves before the brake starts to engage is called freeplay.

Measured at the tip of the front brake lever (1), freeplay should be maintained at:

20–30 mm (0.8–1.2 in)

Adjust the freeplay of the brake lever with the front wheel pointed straight ahead.

Adjustment:

1. Pull back the rubber dust cover (2). Loosen the lock nut (3) and turn the cable adjuster (4). Tighten the lock nut and check the adjustment.

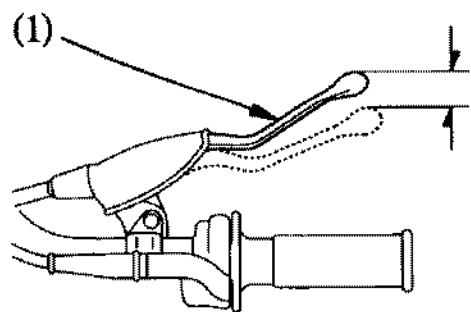

(1) Front brake lever

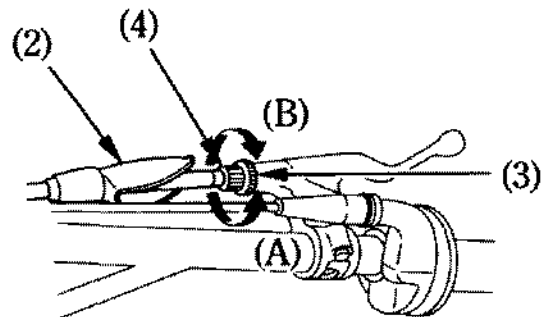

(2) Rubber dust cover (A) Decrease freeplay
(3) Lock nut (B) Increase freeplay
(4) Cable adjuster

2. If the adjuster is threaded out near its limit or the correct freeplay cannot be obtained using the cable adjuster, loosen the lock nut and turn in the cable adjuster completely. Tighten the lock nut and install the rubber dust cover.
3. Loosen the front brake cable guide bolt (5).

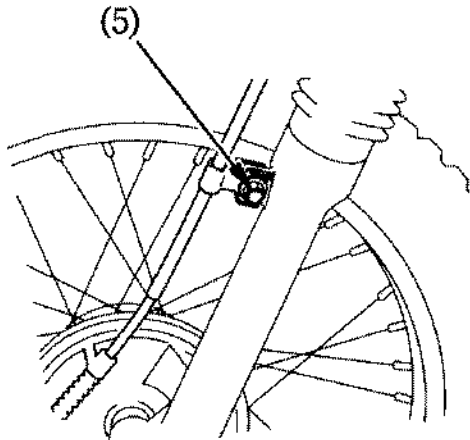

(5) Cable guide bolt

4. Loosen the lock nut (6) at the lower end of the cable. Turn the adjusting nut (7) to obtain the specified freeplay. Tighten the lock nut and check the adjustment.

If proper adjustment cannot be obtained by this method, see your Honda dealer.

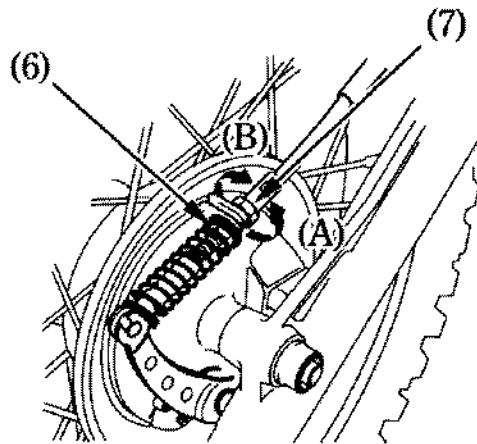

- (6) Lock nut
- (7) Adjusting nut

- (A) Decrease freeplay
- (B) Increase freeplay

5. Apply the brake several times and check for free wheel rotation after the brake lever is released.
Tighten the front brake cable guide bolt.

After adjustment, push the brake arm (8) to confirm that there is proper freeplay.

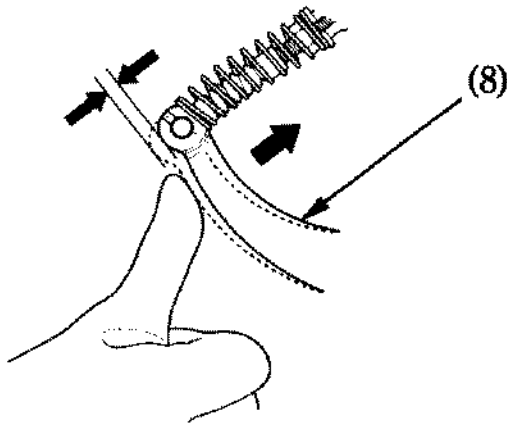

(8) Brake arm

After adjustment, confirm the freeplay of the brake lever.

Other Checks:

Check the brake cable for kinks or signs of wear that could cause sticking or failure. Lubricate the brake cable with a commercially available cable lubricant to prevent premature wear and corrosion. Make sure the brake arm, spring and fasteners are in good condition.

Rear Brake

Pedal Height Adjustment:

1. Place the motorcycle on its side stand.
2. The stopper bolt (1) is provided to allow adjustment of the pedal height.
To adjust the pedal height, loosen the lock nut (2) and turn the stopper bolt. Tighten the lock nut.

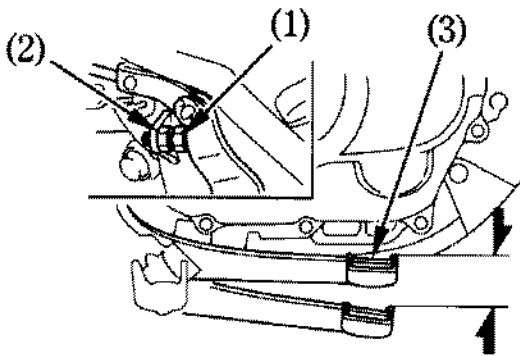

- (1) Stopper bolt (3) Rear brake pedal
(2) Lock nut

Brake Adjustment:

1. Place the motorcycle on its side stand.
2. Measure the distance the rear brake pedal (3) moves before the brake starts to take hold.
Freeplay should be:
20–30 mm (0.8–1.2 in)
3. If adjustment is necessary, turn the rear brake adjusting nut (4).

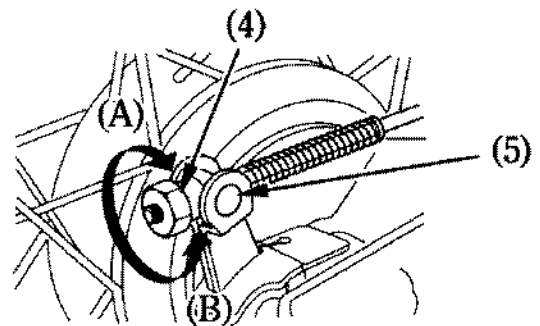

- (4) Rear brake adjusting nut (A) Decrease freeplay
(5) Brake arm pin (B) Increase freeplay

Adjust by turning the rear brake adjusting nut (4) a half-turn at a time. Make sure the cut-out on the adjusting nut is seated on the brake arm pin (5) after making final freeplay adjustment.

4. Apply the brake several times and check for free wheel rotation after the brake pedal is released.

If proper adjustment cannot be obtained by this method, see your Honda dealer.

After adjustment, push the brake arm (6) to confirm that there is a gap between the rear brake adjusting nut and the brake arm pin.

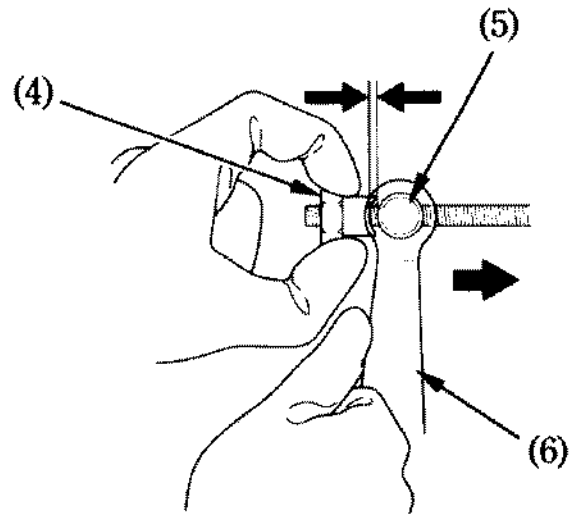

(4) Rear brake adjusting nut

(5) Brake arm pin
(6) Brake arm

After adjustment, confirm the freeplay of the brake pedal.

Other Checks:

Make sure the brake rod, brake arm, spring and fasteners are in good condition.

CLUTCH

Clutch adjustment may be required if the motorcycle stalls when shifting into gear or tends to creep; or if the clutch slips, causing acceleration to lag behind engine speed. Minor adjustments can be made with the clutch cable adjuster (4) at the clutch lever (1).

Normal clutch lever freeplay is:
10–20 mm (0.4–0.8 in)

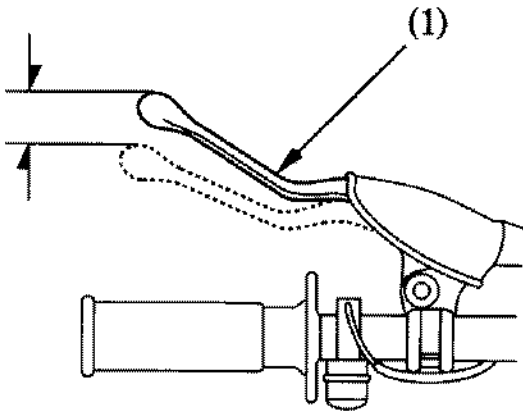

(1) Clutch lever

1. Pull back the rubber dust cover (2).
2. Loosen the lock nut (3) and turn the clutch cable adjuster (4). Tighten the lock nut and check the adjustment.
3. If the adjuster is threaded out near its limit or if the correct freeplay cannot be obtained, loosen the lock nut and turn in the clutch cable adjuster completely. Tighten the lock nut and install the rubber dust cover.

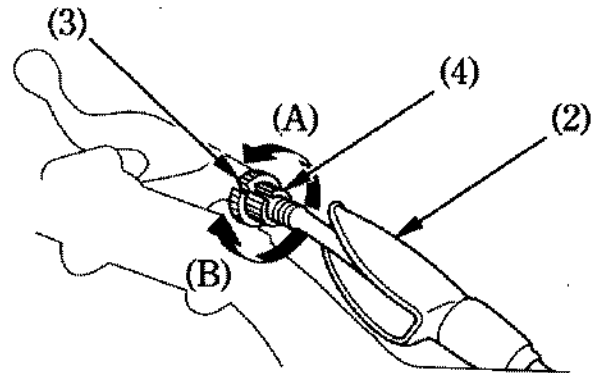

- | | |
|---------------------------|-----------------------|
| (2) Rubber dust cover | (A) Decrease freeplay |
| (3) Lock nut | (B) Increase freeplay |
| (4) Clutch cable adjuster | |

4. Loosen the lock nut (5) at the lower end of the cable. Turn the adjusting nut (6) to obtain the specified freeplay. Tighten the lock nut and check the adjustment.

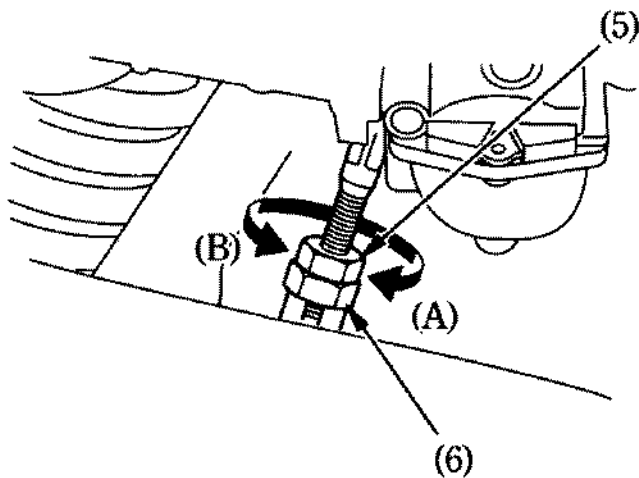

- | | |
|-------------------|-----------------------|
| (5) Lock nut | (A) Decrease freeplay |
| (6) Adjusting nut | (B) Increase freeplay |

5. Clutch adjustment is made at the clutch housing according to the maintenance schedule (page 49) or when normal cable adjustment cannot obtain specified freeplay. Before adjusting the clutch, turn the cable adjuster all the way in to provide maximum freeplay. Then loosen the lock nut (7) and turn the clutch adjuster (8) counterclockwise until a slight resistance is felt. Turn the adjuster back clockwise 1/8 to 1/4 turn and tighten the lock nut, then readjust the lower cable adjuster for proper freeplay.

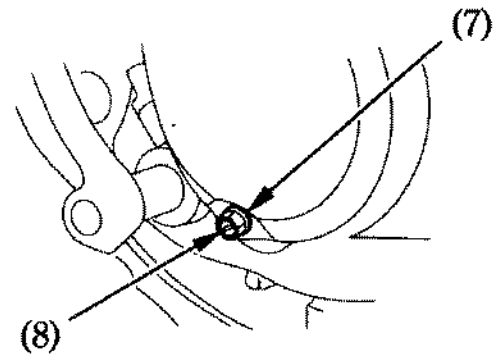

- | | |
|--------------|---------------------|
| (7) Lock nut | (8) Clutch adjuster |
|--------------|---------------------|

6. Start the engine, pull in the clutch lever and shift into gear. Make sure the engine does not stall and the motorcycle does not creep. Gradually release the clutch lever and open the throttle. The motorcycle should begin to move smoothly and accelerate gradually.

If proper adjustment cannot be obtained or the clutch does not work correctly, see your Honda dealer.

Other Checks:

Check the clutch cable for kinks or signs of wear that could cause sticking or failure. Lubricate the clutch cable with a commercially available cable lubricant to prevent premature wear and corrosion.

FUEL

Fuel Valve

The three way fuel valve (1) is on the left side near the carburetor.

OFF

With the fuel valve in the OFF position, fuel cannot flow from the tank to the carburetor. Turn the valve OFF whenever the motorcycle is not in use.

ON

With the fuel valve in the ON position, fuel will flow from the main fuel supply to the carburetor.

RES

With the fuel valve in the RES position, fuel will flow from the reserve fuel supply to the carburetor. Use the reserve fuel only when the main supply is gone. Refill the tank as soon as possible after switching to RES.

The reserve fuel supply is:

0.7 l (0.18 US gal , 0.15 Imp gal)

Remember to check that the fuel valve is in the ON position each time you refuel. If the valve is left in the RES position, you may run out of fuel with no reserve.

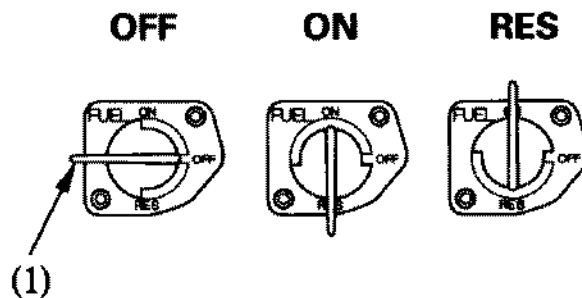

(1) Fuel valve

Fuel Tank

The fuel tank capacity including the reserve supply is:

5.0 ℓ (1.32 US gal , 1.10 Imp gal)

To open the fuel fill cap (1), pull the breather tube (2) from the front number plate (3). Turn the fuel fill cap counterclockwise.

Do not overfill the tank. There should be no fuel in the filler neck (4).

After refueling, be sure to tighten the fuel fill cap firmly by turning it clockwise. Insert the breather tube into the front number plate.

⚠ WARNING

Petrol is highly flammable and explosive. You can be burned or seriously injured when handling fuel.

- Stop the engine and keep heat, sparks, and flame away.
- Refuel only outdoors.
- Wipe up spills immediately.

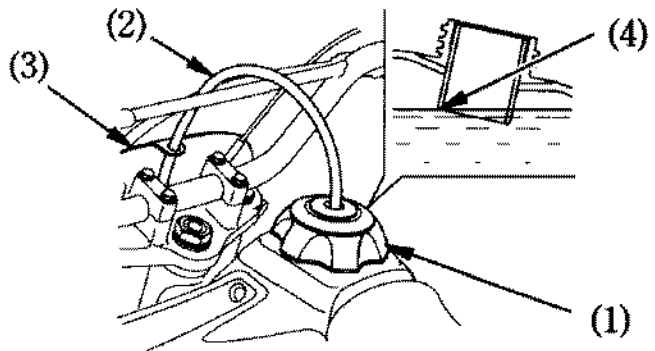

(1) Fuel fill cap
(2) Breather tube

(3) Front number plate
(4) Filler neck

For U:

Use unleaded or low-lead petrol with a research octane number of 91 or higher. We recommend that you use unleaded petrol because it produces fewer engine and spark plug deposits and extends the life of exhaust system components.

For Mexico:

Use unleaded or low-lead petrol with a research octane number of 88 or higher. Recommended – Extra petrol.

NOTICE

If “spark knock” or “pinking” occurs at a steady engine speed under normal load, change brands of petrol. If spark knock or pinking persists, consult your Honda dealer. Failure to do so is considered misuse, and damage caused by misuse is not covered by Honda’s Limited Warranty.

Occasionally you may experience light spark knock while operating under heavy loads. This is no cause for concern, it simply means your engine is operating efficiently.

Petrol Containing Alcohol

If you decide to use a petrol containing alcohol (gasohol), be sure it's octane rating is at least as high as that recommended by Honda. There are two types of "gasohol": one containing ethanol, and the other containing methanol. Do not use petrol that contains more than 10 % ethanol. Do not use petrol containing methanol (methyl or wood alcohol) that does not also contain cosolvents and corrosion inhibitors for methanol. Never use petrol containing more than 5 % methanol, even if it has cosolvents and corrosion inhibitors.

Fuel system damage or engine performance problems resulting from the use of fuels that contain alcohol is not covered under the warranty. Honda cannot endorse the use of fuels containing methanol since evidence of their suitability is as yet incomplete.

Before buying fuel from an unfamiliar station, try to find out if the fuel contains alcohol. If it does, confirm the type and percentage of alcohol used. If you notice any undesirable operating symptoms while using a petrol that contains alcohol, or one that you think contains alcohol, switch to a petrol that you know does not contain alcohol.

ENGINE OIL

Engine Oil Level Check

Check the engine oil level each day before operating the motorcycle.

The oil filler cap/dipstick (1) is at the rear of the right crankcase cover and contains a dipstick for measuring the oil level. Oil level must be maintained between the upper (2) and lower (3) level marks on the oil filler cap/dipstick.

1. Hold the motorcycle upright on firm level ground.
2. Start the engine and let it idle for 3–5 minutes.
3. Stop the engine. After 2–3 minutes, remove the oil filler cap/dipstick, wipe it clean, and reinsert the oil filler cap/dipstick without screwing it in. Remove the oil filler cap/dipstick. The oil level should be between the upper and lower level marks on the oil filler cap/dipstick.

4. If required, add the specified oil (page 56) up to the upper level mark. Do not overfill.
5. Reinstall the oil filler cap/dipstick. Check for oil leaks.

NOTICE

Running the engine with insufficient oil can cause serious engine damage.

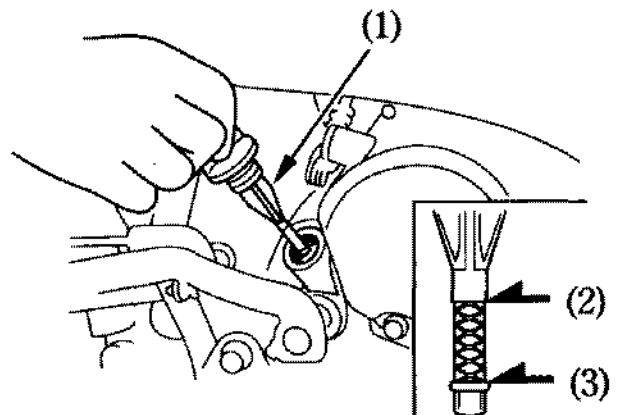

- (1) Oil filler cap/dipstick
- (2) Upper level mark
- (3) Lower level mark

TYRES

To safely operate your motorcycle, the tyres must be the proper type (off-road) and size, in good condition with adequate tread, and correctly inflated.

⚠ WARNING

Using tyres that are excessively worn or improperly inflated can cause a crash in which you can be seriously hurt or killed.

Follow all instructions in this owner's manual regarding tyre inflation and maintenance.

Air Pressure

Properly inflated tyres provide the best combination of handling, tread life, and riding comfort. Generally, underinflated tyres wear unevenly, adversely affect handling, and are more likely to fail from being overheated. Underinflated tyres can also cause wheel damage in rocky terrain. Overinflated tyres make your motorcycle ride harshly, are more prone to damage from surface hazards, and wear unevenly.

Make sure the valve stem caps are secure. If necessary, install new caps.

Always check air pressure when your tyres are “cold.” If you check air pressure when your tyres are “warm”—even if your motorcycle has only been ridden for a few miles—the readings will be higher. If you let air out of warm tyres to match the recommended cold pressures, the tyres will be underinflated.

The recommended “cold” tyre pressures are:

Front	100 kPa (1.0 kgf/cm ² , 15 psi)
Rear	100 kPa (1.0 kgf/cm ² , 15 psi)

Inspection

Whenever you check the tyre pressures, you should also examine the tyre treads and sidewalls for wear, damage, and foreign objects:

Look for:

- Bumps or bulges in the side of the tyre or the tread. Replace the tyre if you find any bumps or bulges.
- Cuts, splits or cracks in the tyre. Replace the tyre if you can see fabric or cord.
- Excessive tread wear.

Also, if you hit a pothole or hard object, pull to the side of the road as soon as you can safely and carefully inspect the tyres for damage.

Tread Wear

Replace tyres before tread depth (1) at the center of the tyre reaches the following limit:

Minimum tread depth	
Front:	3.0 mm (0.12 in)
Rear:	3.0 mm (0.12 in)

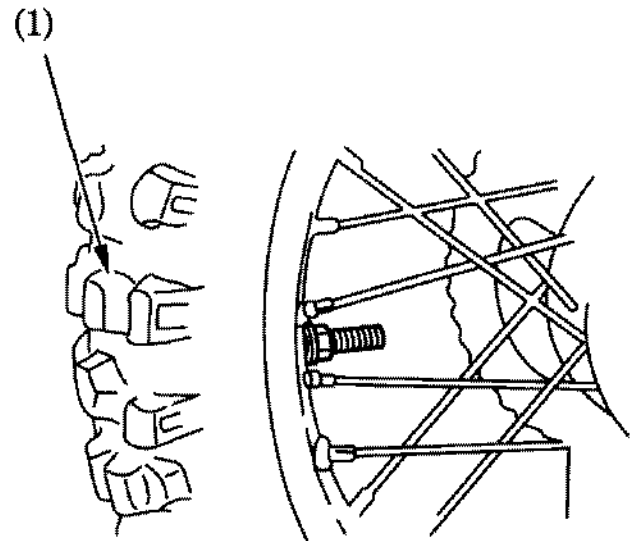

(1) Tread depth

Tube Repair and Replacement

If a tube is punctured or damaged, you should replace it as soon as possible. A tube that is repaired may not have the same reliability as a new one, and it may fail while you are riding.

If you need to make a temporary repair by patching a tube or using an aerosol sealant, ride cautiously at reduced speed and have the tube replaced before you ride again. Any time a tube is replaced, the tyre should be carefully inspected as described on page 28 .

Tyre Replacement

The tyres that came on your motorcycle were designed to match the performance capabilities of your motorcycle and provide the best combination of handling, braking, durability and comfort.

⚠ WARNING

Installing improper tyres on your motorcycle can affect handling and stability. This can cause a crash in which you can be seriously hurt or killed.

Always use the size and type of tyres recommended in this owner's manual.

The recommended tyres for your motorcycle are:

Front: 2.50 – 16 4PR

Rear: 3.60 – 14 4PR

Type: bias-ply, tube

Whenever you replace a tyre, use one that is equivalent to the original and be sure the wheel is balanced after the new tyre is installed.

Also remember to replace the inner tube whenever you replace a tyre. The old tube will probably be stretched, and if installed in a new tyre, it could fail.

ESSENTIAL INDIVIDUAL COMPONENTS

IGNITION SWITCH

The ignition switch (1) is located below the fuel tank.

The ignition switch is used to prevent unauthorized use of the motorcycle. Before riding, insert the key and turn it to the ON position.

After parking the motorcycle, remove the key.

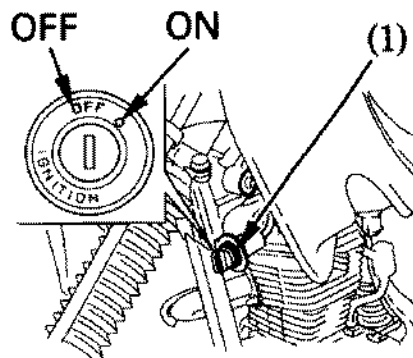

(1) Ignition switch

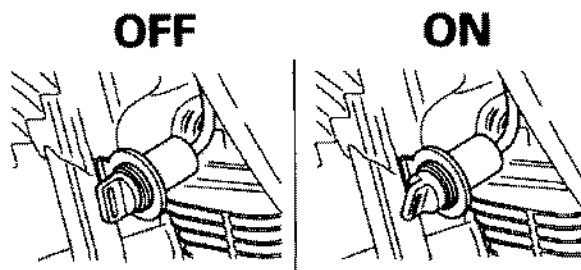

Key Position	Function	Key Removal
OFF	The engine cannot be operated.	Key can be removed
○ (ON)	With the transmission in neutral, the engine can be started.	Key cannot be removed



ENGINE STOP BUTTON

The engine stop button (1) is next to the left handlebar grip.

Push the button in and hold it in until the engine stops completely.

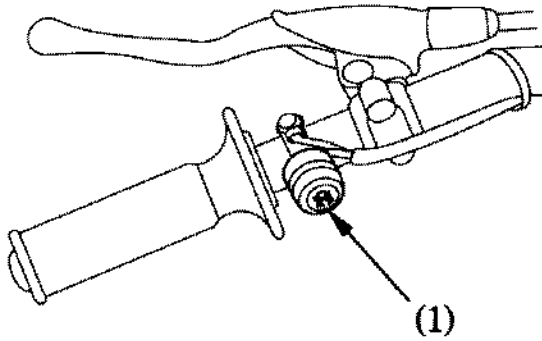

(1)

(1) Engine stop button

FEATURES

(Not required for operation)

SIDE COVER

Removal:

1. Remove the bolt (1) securing the side cover.
2. Pull both side cover prongs (2) out of the rubber grommets (3).

Installation:

1. Slide the top of the side cover under the bottom edge of the seat.
2. Align the side cover prongs with the rubber grommets. Press the side cover into position.
3. Install the securing bolt and tighten it.

Use the same procedure to remove and install the left side cover.

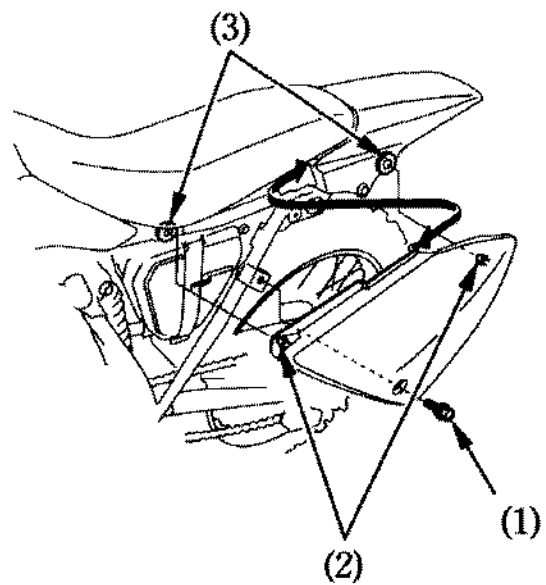

- (1) Bolt
- (2) Prongs
- (3) Grommets

OPERATION

PRE-RIDE INSPECTION

For your safety, it is very important to take a few moments before each ride to walk around your motorcycle and check its condition. If you detect any problem, be sure you take care of it, or have it corrected by your Honda dealer.

⚠ WARNING

Improperly maintaining this motorcycle or failing to correct a problem before riding can cause a crash in which you can be seriously hurt or killed.

Always perform a pre-ride inspection before every ride and correct any problems.

1. Engine oil level—add engine oil if required (page 26). Check for leaks.
2. Fuel level—fill fuel tank when necessary (page 23). Check for leaks.
3. Front and rear brakes—check operation and if necessary, adjust freeplay (pages 14 – 18).
4. Tyres—check condition and pressure (pages 27 – 31).
5. Spokes and rim locks—check and tighten if necessary (page 72).
6. Drive chain—check condition and slack (page 67). Adjust and lubricate if necessary.
7. Chain slider—check slider wear (page 68).
8. Throttle—check for smooth opening and full closing in all steering positions. Adjust freeplay if necessary (pages 64 – 65).

9. Clutch—check operation, and adjust if necessary (pages 19 – 21).
10. Spark plug and high tension terminal – check for looseness.
11. Engine stop button—check for proper function (page 33).
12. Nuts, bolts, fasteners – check the front and rear wheels to see that the axle nuts are tightened securely. Check security of all other nuts, bolts, and fasteners.

STARTING THE ENGINE

Always follow the proper starting procedure described below.

This motorcycle can be kickstarted with the transmission in gear by disengaging the clutch before operating the kickstarter.

Your motorcycle's exhaust contains poisonous carbon monoxide gas. High levels of carbon monoxide can collect rapidly in enclosed areas such as a garage. Do not run the engine with the garage door closed. Even with the door open, run the engine only long enough to move your motorcycle out of the garage.

Preparation

Before starting, insert the key and turn the ignition switch ON.

Make sure that the transmission is in neutral. Turn the fuel valve ON.

Starting Procedure

To restart a warm engine, follow the procedure for "High Air Temperature."

Normal Air Temperature

10° – 35° C (50° – 95° F)

1. Pull the choke lever (1) up all the way to Fully ON (A).

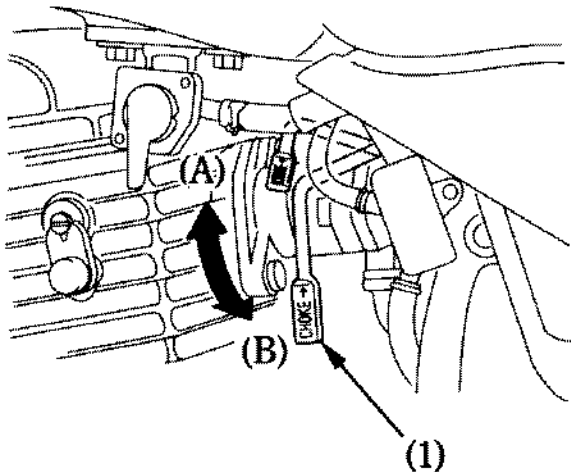

(1) Choke lever

(A) Fully ON

(B) Fully OFF

2. With the throttle slightly open, operate the kickstarter. Kick from the top of the stroke through to the bottom with a rapid, continuous motion.

NOTICE

Allowing the kickstarter to snap back freely against the pedal stop can damage the engine case.

3. Warm up the engine by opening and closing the throttle slightly.
4. About a quarter minute after the engine starts, push the choke lever down all the way to Fully OFF (B).
5. If idling is unstable, open the throttle slightly.

High Air Temperature

35°C (95°F) or above

1. Do not use the choke.
2. Start the engine following step 2 under “Normal Air Temperature.”

Low Air Temperature

10°C (50°F) or below

1. Follow steps 1–2 under “Normal Air Temperature”.
2. Warm up the engine by opening and closing the throttle slightly.
3. Continue warming up the engine until it runs smoothly and responds to the throttle, when the choke lever is at Fully OFF (B).

NOTICE

Extended use of the choke may impair piston and cylinder wall lubrication and damage the engine.

Flooded Engine

If the engine fails to start after repeated attempts, it may be flooded with excess fuel. To clear a flooded engine, push the choke lever down to Fully OFF (B). Open the throttle fully and crank the engine several times with the kickstarter while pushing the engine stop button. Release the engine stop button and follow the "High Air Temperature" Starting Procedure (page 39).

RUNNING-IN

Help assure your motorcycle's future reliability and performance by paying extra attention to how you ride during the first operating day or 25 km (15 miles). During this period, avoid full-throttle starts and rapid acceleration.

RIDING

Review Motorcycle Safety (pages 1 – 10) before you ride.

Make sure the side stand is fully retracted before riding the motorcycle. If the stand is extended, it may interfere with control during a left turn.

Make sure you understand the function of the side stand mechanism. (See MAINTENANCE SCHEDULE on page 51 and explanation for SIDE STAND on page 79).

1. After the engine has been warmed up, the motorcycle is ready for riding.
2. While the engine is idling, pull in the clutch lever and depress the shift lever to shift into 1st (low) gear.

3. Slowly release the clutch lever and at the same time gradually increase engine speed by opening the throttle. Coordination of the throttle and clutch lever will assure a smooth positive start.

4. When the motorcycle attains a moderate speed, close the throttle, pull in the clutch lever and shift to 2nd gear by raising the shift lever.

This sequence is repeated to progressively shift to 3rd, 4th and 5th (top) gears.

5. Raise the shift lever to shift to a higher gear and depress the shift lever to shift to a lower gear. Each stroke of the shift lever engages the next gear in sequence. The shift lever automatically returns to the horizontal position when released.

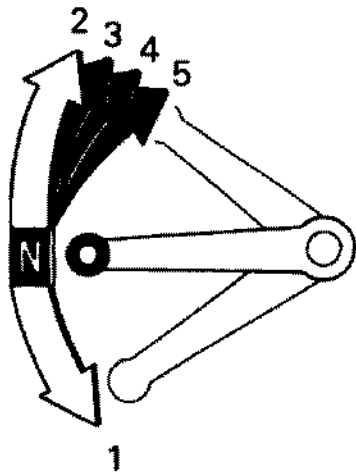

- Do not downshift when traveling at a speed that would force the engine to overrev in the next lower gear; the rear wheel may lose traction, resulting in a possible loss of vehicle control.
- Do not shift gears without disengaging the clutch and closing the throttle. The engine and drive train could be damaged by overspeed and shock.
- Do not tow the motorcycle or coast for long distances while the engine is off. The transmission will not be properly lubricated and damage may result.
- Do not run the engine at high rpm with the transmission in neutral or the clutch lever pulled in. Serious engine damage may result.

HIGH ALTITUDE RIDING (Except Mexico)

When operating this motorcycle at high altitude the air-fuel mixture becomes overly rich. Driveability and performance may be reduced and fuel consumption increased. The carburetor can be modified to compensate for this high altitude richness, however it must be returned to standard specifications before extended operation at low altitudes (below 1,200 m, 4,000 feet). See your Honda dealer for this high altitude modification.

NOTICE

Sustained operation at lower altitudes with high altitude carburetor modifications may cause engine overheating and damage.

LOW ALTITUDE RIDING (Mexico only)

When operating this motorcycle at low altitude, the air-fuel mixture becomes overly lean. Below 1,000 m (3,300 feet), driveability and performance may be reduced. The carburetor can be modified to compensate for this low altitude leanness. However, the carburetor must be returned to standard factory specifications when higher altitude riding is desired. See your Honda dealer for low altitude adjustments.

NOTICE

Sustained operation at altitudes above 1,500 m (5,000 feet) with low altitude carburetor modifications may cause flooded engine.

BRAKING

For normal braking, gradually apply both the front and rear brakes while downshifting to suit your road speed.

For maximum deceleration, close the throttle and apply the front and rear brakes firmly. Pull in the clutch lever before coming to a complete stop to prevent stalling the engine.

Important Safety Reminders:

- Independent operation of only the brake lever or brake pedal reduces stopping performance.
- Extreme application of the brake controls may cause wheel lock, reducing control of the motorcycle.
- When possible, reduce speed or brake before entering a turn; closing the throttle or braking in mid-turn may cause wheel slip. Wheel slip will reduce control of the motorcycle.
- When riding in wet or rainy conditions, or on loose surfaces, the ability to maneuver and stop will be reduced. All of your actions should be smooth under these conditions. Rapid acceleration, braking or turning may cause loss of control. For your safety, exercise extreme caution when braking, accelerating or turning.
- When descending a long, steep grade, use engine compression braking by downshifting, with intermittent use of both brakes.
Continuous brake application can overheat the brakes and reduce their effectiveness.

PARKING

1. After stopping the motorcycle, shift the transmission into neutral and turn the fuel valve OFF. Push the engine stop button in and hold it in until the engine stops completely.
2. Use the side stand to support the motorcycle while parked.

Park the motorcycle on firm, level ground to prevent it from falling over.

If you must park on a slight incline, aim the front of the motorcycle uphill to reduce the possibility of rolling off the side stand or overturning.

3. Turn the ignition switch OFF and remove the key.

ANTI-THEFT TIPS

1. Be sure the registration information for your motorcycle is accurate and current.
2. Park your motorcycle in a locked garage whenever possible.
3. Use an additional anti-theft device of good quality.
4. Put your name, address and phone number in this Owner's Manual and keep it on your motorcycle at all times. Many times stolen motorcycles are identified by information in the Owner's Manuals which are still with them.

NAME: _____

ADDRESS: _____

PHONE NO: _____

MAINTENANCE

THE IMPORTANCE OF MAINTENANCE

A well-maintained motorcycle is essential for safe, economical, and trouble-free riding. It will also help reduce air pollution. Careful pre-ride inspections and good maintenance are especially important because your motorcycle is designed to be ridden over rough off-road terrain.

To help you properly care for your motorcycle, this section of the manual provides a Maintenance Schedule.

The service intervals in this schedule are based on average riding conditions.

More frequent service is needed if you subject your motorcycle to severe use (such as competition) or ride in unusually wet or dusty areas.

Frequent servicing of the air cleaner is especially important to help you avoid a possible costly engine repair.

If your motorcycle overturns or becomes involved in a crash, be sure your Honda dealer inspects all major parts, even if you are able to make some repairs.

▲ WARNING

Improperly maintaining this motorcycle or failing to correct a problem before you ride can cause a crash in which you can be seriously hurt or killed.

Always follow the inspection and maintenance recommendations and schedules in this owner's manual.

MAINTENANCE SAFETY

This section includes instructions on some important maintenance tasks. You can perform some of these tasks with the tools provided — if you have basic mechanical skills.

Other tasks that are more difficult and require special tools are best performed by professionals. Wheel removal should normally be handled only by a Honda technician or other qualified mechanic; instructions are included in this manual only to assist in emergency service.

Some of the most important safety precautions follow. However, we cannot warn you of every conceivable hazard that can arise in performing maintenance. Only you can decide whether or not you should perform a given task.

⚠ WARNING

Failure to properly follow maintenance instructions and precautions can cause you to be seriously hurt or killed.

Always follow the procedures and precautions in this owner's manual.

SAFETY PRECAUTIONS

- **Make sure the engine is off before you begin any maintenance or repairs.** This will help eliminate several potential hazards:
 - **Carbon monoxide poisoning from engine exhaust.**
Be sure there is adequate ventilation whenever you operate the engine.
 - **Burns from hot parts.**
Let the engine and exhaust system cool before touching.
 - **Injury from moving parts.**
Do not run the engine unless instructed to do so.
- **Read the instructions before you begin, and make sure you have the tools and skills required.**
- **To help prevent the motorcycle from falling over, park it on a firm, level surface, using the side stand or a maintenance stand to provide support.**

- **To reduce the possibility of a fire or explosion, be careful when working around petrol. Use only nonflammable solvent, not petrol, to clean parts. Keep cigarettes, sparks and flames away from all fuel-related parts.**

Remember that your Honda dealer knows your motorcycle best and is fully equipped to maintain and repair it.

To ensure the best quality and reliability, use only new Honda Genuine Parts or their equivalents for repair and replacement.

MAINTENANCE SCHEDULE

Perform the Pre-ride Inspection (page 35) at each scheduled maintenance period.

I: INSPECT AND CLEAN, ADJUST, LUBRICATE OR REPLACE IF NECESSARY

C: CLEAN R: REPLACE A: ADJUST L: LUBRICATE

The following Maintenance Schedule specifies all maintenance required to keep your motorcycle in peak operating condition. Maintenance work should be performed in accordance with standards and specifications of Honda by properly trained and equipped technicians. Your Honda dealer meets all of these requirements.

- * Should be serviced by your Honda dealer, unless the owner has proper tools and service data and is mechanically qualified. Refer to the Official Honda Shop Manual.
- ** In the interest of safety, we recommend these items be serviced only by your Honda dealer.

Honda recommends that your Honda dealer should road test your motorcycle after each periodic maintenance is carried out.

NOTE: (1) Service more frequently when ridden in wet or dusty conditions.

ITEMS	FREQUENCY	WHICHEVER → COMES FIRST ↓ NOTE	MONTH	INITIAL MAINT.	REGULAR MAINT. INTERVAL					REFER TO PAGE
				150	1,000	2,000	3,000	4,000		
				100	600	1,200	1,800	2,400		
* FUEL LINE						I		I	—	
** FUEL STRAINER SCREEN						C		C	—	
* THROTTLE OPERATION						I		I	64	
AIR CLEANER		NOTE (1)			C	C	C	C	55	
SPARK PLUG					I	I	I	I	61	
* VALVE CLEARANCE				I	I	I	I	I	—	
ENGINE OIL				R	R	R	R	R	56	
** ENGINE OIL STRAINER SCREEN						C		C	—	
* CAM CHAIN TENSION				A	A	A	A	A	—	
** ENGINE IDLE SPEED				I	I	I	I	I	63	

ITEMS	FREQUENCY	WHICHEVER → COMES FIRST ↓ NOTE	MONTH	INITIAL MAINT.	REGULER MAINT. INTERVAL				REFER TO PAGE
				150	1,000	2,000	3,000	4,000	
				100	600	1,200	1,800	2,400	
DRIVE CHAIN		NOTE (1)		I,L	Every 500 km (300 mi) or every 3 months: I,L				67
DRIVE CHAIN SLIDER					I	I	I	I	68
BRAKE SHOE WEAR					I	I	I	I	76
BRAKE SYSTEM				I	I	I	I	I	14,17,76
CLUTCH SYSTEM				I	I	I	I	I	19
SIDE STAND						I		I	79
* SUSPENSION						I		I	77,78
* SPARK ARRESTER					Every 1,600 km (1,000 mi) or every 100 operating hours: C				66
* NUTS, BOLTS, FASTENERS				I		I		I	—
** WHEELS/TYRES				I	I	I	I	I	27,72
** STEERING HEAD BEARINGS				I		I		I	—

TOOL KIT

The spark plug wrench (1) and its handle (2) are stored in the tool bag (3).

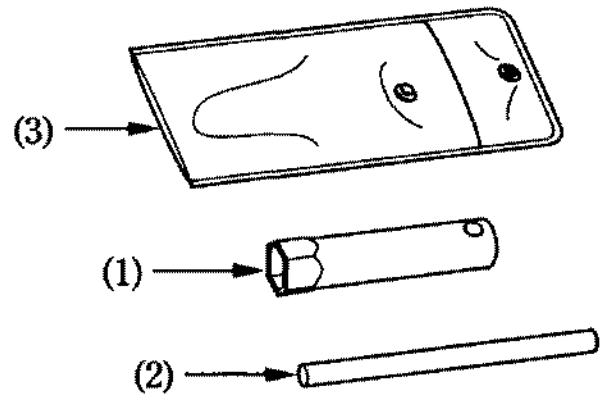

- (1) Spark plug wrench
- (2) Handle
- (3) Tool bag

SERIAL NUMBERS

The frame and engine serial numbers are required when registering your motorcycle. They may also be required by your dealer when ordering replacement parts. Record the numbers here for your reference.

FRAME NO. _____

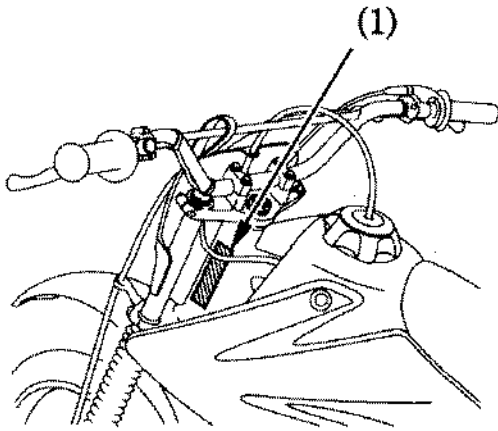

(1) Frame number

The frame number (1) is stamped on the left side of the steering head.

The engine number (2) is stamped on the left side of the engine.

ENGINE NO. _____

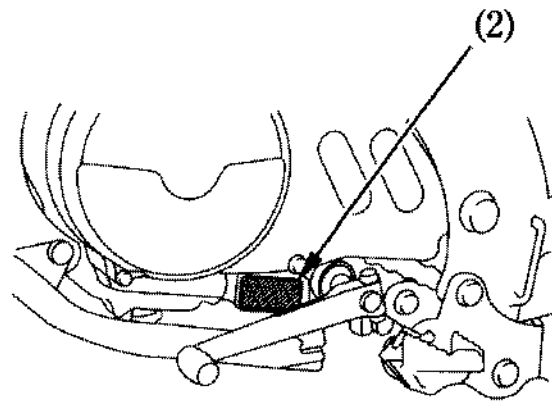

(2) Engine number

COLOUR LABEL

The colour label (1) is attached to the frame behind the left side cover (page 34). It is helpful when ordering replacement parts. Record the colour and code here for your reference.

COLOUR _____

CODE _____

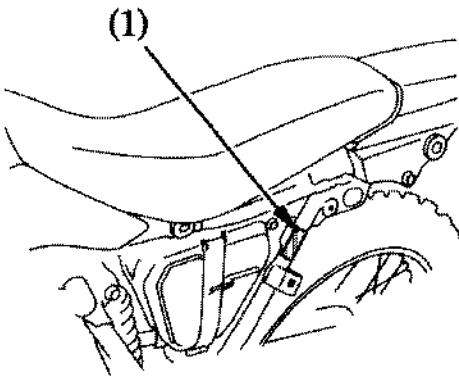

(1) Colour label

54

AIR CLEANER

Refer to the Safety Precautions on page 48 .

The air cleaner should be serviced at regular intervals (page 50). Service more frequently when riding in unusually wet or dusty areas.

1. Remove the left side cover (page 34).
2. Remove the rubber band (1) from the hook (2) and remove the air cleaner housing cover (3). Unhook the retainer (4) and remove the air cleaner (5).

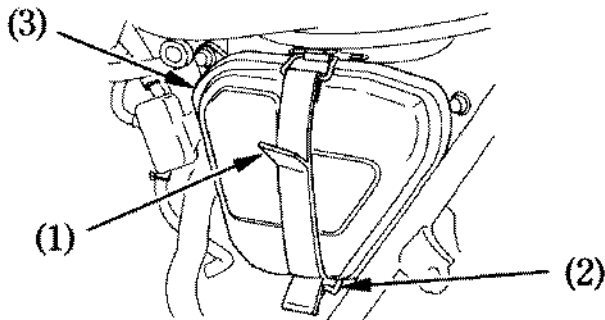

- (1) Rubber band
(2) Hook

- (3) Air cleaner
housing cover

3. Wash the air cleaner in clean, nonflammable or high flash point solvent and let it dry thoroughly.

Never use petrol or low flash point solvents for cleaning the air cleaner. A fire or explosion could result.

4. Soak the air cleaner in gear oil (SAE 80—90) until saturated, then squeeze out the excess oil.
5. Reinstall the air cleaner.
6. Reinstall the left side cover.

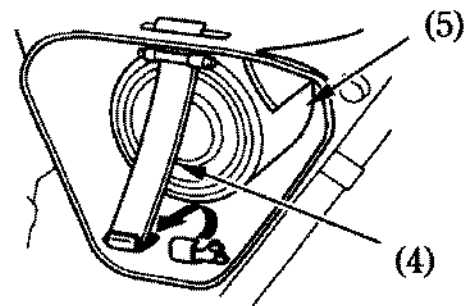

- (4) Retainer

- (5) Air cleaner

ENGINE OIL

Refer to the Safety Precautions on page 48 .

Oil Recommendation

API classification	SG or higher except oils labeled as energy conserving on the circular API service label
Viscosity	SAE 10W-30
JASO T 903 standard	MA

Suggested Oil
Honda "4-STROKE MOTORCYCLE OIL" or equivalent.

Your motorcycle does not need oil additives. Use the recommended oil.

Do not use oils with graphite or molybdenum additives. They may adversely affect clutch operation.

Do not use API SH or higher oils displaying a circular API "energy conserving" service label on the container. They may affect lubrication and clutch performance.

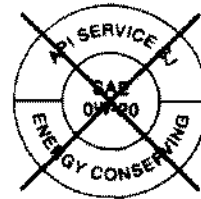

NOT RECOMMENDED



OK

Do not use non-detergent, vegetable, or castor based racing oils.

Viscosity:

Viscosity grade of engine oil should be based on average atmospheric temperature in your riding area. The following provides a guide to the selection of the proper grade or viscosity of oil to be used at various atmospheric temperatures.

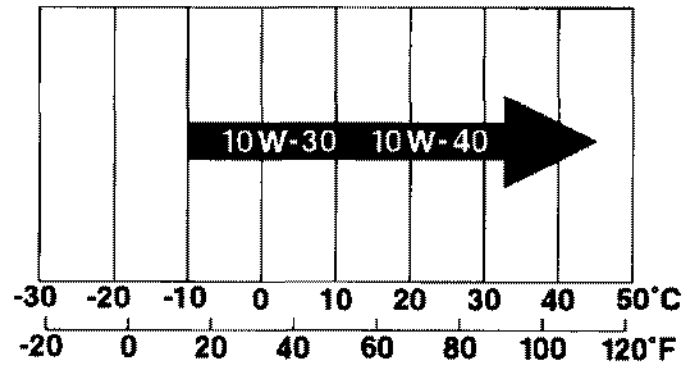

JASO T 903 standard

The JASO T 903 standard is an index for engine oils for 4-stroke motorcycle engines.

There are two classes: MA and MB.

Oil conforming to the standard is labeled on the oil container. For example, the following label shows the MA classification.

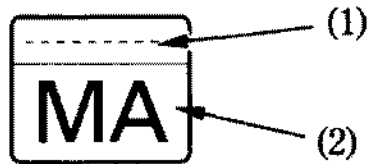

PRODUCT MEETING JASO T 903
COMPANY GUARANTEEING THIS MA PERFORMANCE:

- (1) Code number of the sales company of the oil
- (2) Oil classification

Engine Oil

Engine oil quality is the chief factor affecting engine service life. Change the engine oil as specified in the maintenance schedule (page 50).

When running in very dusty conditions, oil changes should be performed more frequently than specified in the maintenance schedule.

Please dispose of used engine oil in a manner that is compatible with the environment. We suggest you take it in a sealed container to your local recycling center or service station for reclamation. Do not throw it in the trash or pour it on the ground or down a drain.

Used engine oil may cause skin cancer if repeatedly left in contact with the skin for prolonged periods. Although this is unlikely unless you handle used oil on a daily basis, it is still advisable to thoroughly wash your hands with soap and water as soon as possible after handling used oil.

Changing the oil requires a torque wrench. If you do not have it and the necessary skill, we recommend that you have your Honda dealer perform this service.

If a torque wrench is not used for this installation, see your Honda dealer as soon as possible to verify proper assembly.

Change the engine oil with the engine at normal operating temperature and the motorcycle on its side stand to assure complete and rapid draining.

1. Remove the oil filler cap/dipstick from the right crankcase cover.
2. Place a drain pan under the crankcase and remove the oil drain bolt (1).
3. Operate the kickstarter several times while pressing the engine stop button to drain any oil which may be left in the engine.
4. Check that the sealing washer (2) on the drain bolt is in good condition and install the bolt. Replace the sealing washer every other time the oil is changed, or each time if necessary.

Oil drain bolt torque:

24 N·m (2.5 kgf·m , 18 lbf·ft)

5. Fill the crankcase with the recommended grade oil; approximately:

0.9 ℓ (1.0 US qt , 0.8 Imp qt)

6. Reinstall the oil filler cap/dipstick.
7. Start the engine and let it idle for 2–3 minutes.
8. Stop the engine and check that the oil level is at the upper level mark on the oil filler cap/dipstick with the motorcycle upright on firm, level ground. Make sure there are no oil leaks.

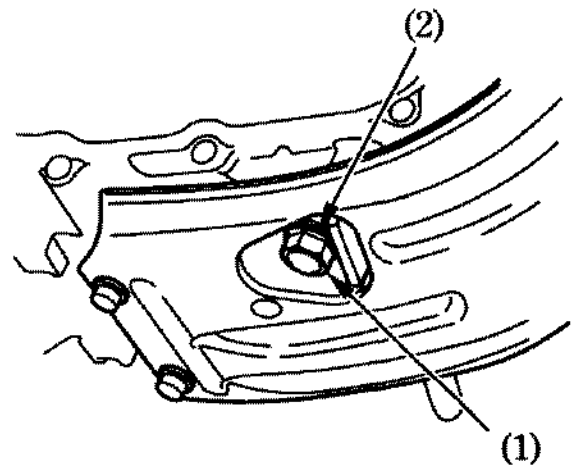

(1) Oil drain bolt

(2) Sealing washer

SPARK PLUG

Refer to the Safety Precautions on page 48 .

Recommended plugs:

Standard:

CR7HSA (NGK) or
U22FSR-U (DENSO)

For cold climate: (Below 5°C, 41°F)

CR6HSA (NGK) or
U20FSR-U (DENSO)

For extended high speed riding:

CR8HSA (NGK) or
U24FSR-U (DENSO)

For most riding conditions this spark plug heat range number is satisfactory. However, if the motorcycle is going to be operated for extended periods at high speeds or near maximum power in hot climates, the spark plug should be changed to a colder heat range (a higher number).

NOTICE

Never use a spark plug with an improper heat range. Severe engine damage could result.

1. Disconnect the spark plug cap.
2. Clean any dirt from around the spark plug base.
3. Remove the spark plug.
4. Visually inspect the spark plug electrodes for wear. The center electrode (1) should have square edges and the side electrode (2) should not be eroded.
5. Discard the spark plug if there is apparent wear or if the insulator is cracked or chipped.

6. Check the spark plug gap (3) using a wire-type feeler gauge. If adjustment is necessary, bend the side electrode (2) carefully.

The gap should be:

0.6–0.7 mm (0.02–0.03 in)

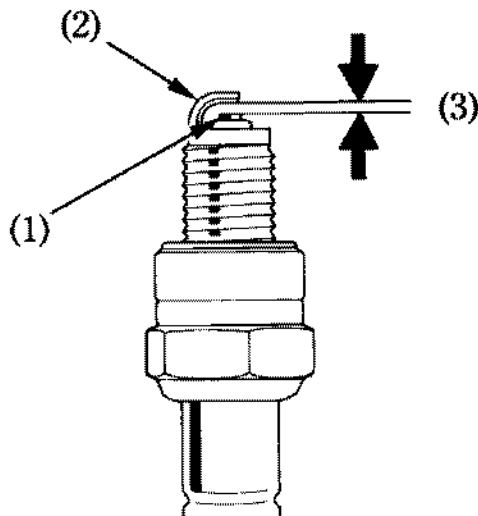

(1) Center electrode

(2) Side electrode

(3) Spark plug gap

7. Make sure the plug washer is in good condition.

8. With the plug washer attached, thread the spark plug in by hand to prevent cross-threading.

9. Tighten the spark plug:

- If the old plug is good:

- 1/8 turn after it seats.

- If installing a new plug, tighten it twice to prevent loosening:

- a) First, tighten the plug:

- NGK: 1 turn after it seats.

- DENSO: 3/4 turn after it seats.

- b) Then loosen the plug.

- c) Next, tighten the plug again:

- 1/8 turn after it seats.

NOTICE

An improperly tightened spark plug can damage the engine. If a plug is too loose, a piston may be damaged. If a plug is too tight, the threads may be damaged.

10. Reinstall the spark plug cap. Take care to avoid pinching any cables or wires.

IDLE SPEED

Refer to the Safety Precautions on page 48 .

Idle Speed:

The engine must be at normal operating temperature for accurate idle speed adjustment. 10 minutes of stop-and-go riding is sufficient.

Do not attempt to compensate for faults in other systems by adjusting idle speed. See your Honda dealer for regularly scheduled carburetor adjustments.

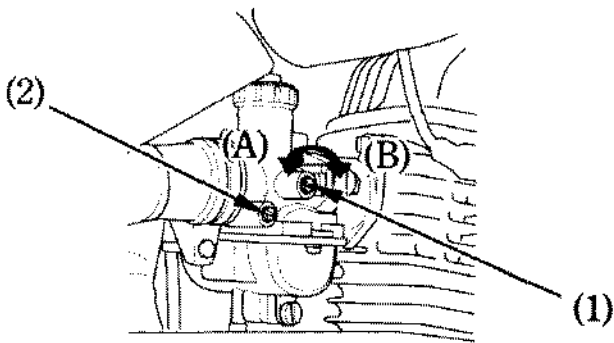

(1) Throttle stop screw

(2) Air screw

(A) Decrease

(B) Increase

1. Warm up the engine and hold the motorcycle upright.
2. Connect a tachometer to the engine.
3. Adjust idle speed with the throttle stop screw (1).

Idle speed (In neutral):

$1,500 \pm 100 \text{ min}^{-1} (\text{rpm})$

Idle Mixture:

1. Adjust the fuel mixture by turning the air screw (2) clockwise until you hear the engine miss or decrease in speed, then counterclockwise until the engine again misses or decreases in speed. Set the air screw exactly between these two extreme positions.

From a fully closed position, the correct setting (between extremes of rich and lean) will be approximately: $2\text{-}1/8$

2. If the idle speed changes after adjusting fuel mixture, readjust the idle speed by turning the throttle stop screw.

THROTTLE OPERATION

Refer to the Safety Precautions on page 48 .

Cable Inspection:

1. Check for smooth rotation of the throttle grip from the fully open to the fully closed position at both full steering positions.
2. Inspect the condition of the throttle cable (1) from the throttle grip down to the carburetor. If the cable is kinked, chafed or improperly routed, it should be replaced and/or rerouted.
3. Lubricate the cable with a commercially available cable lubricant to prevent premature wear and corrosion.

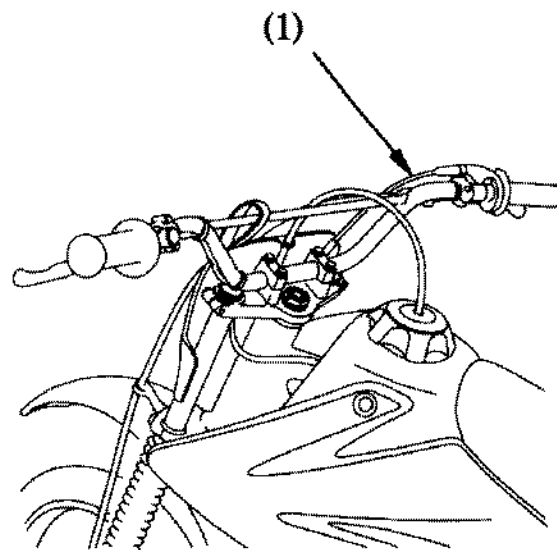

(1) Throttle cable

Freeplay Adjustment:

1. Adjust freeplay with the throttle cable adjuster (2). Measured in grip rotation, the standard throttle grip freeplay is:
2–6 mm (0.1–0.2 in)
2. To adjust the freeplay, loosen the lock nut (3) and turn the adjuster.
3. After adjustment, check again for smooth rotation of the throttle grip from the fully closed to the fully open position with the steering to the full right and left as well as straight ahead.

If proper throttle freeplay cannot be achieved, contact your Honda dealer.

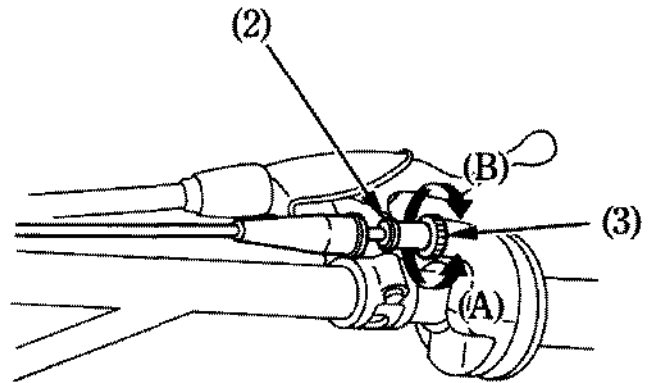

(2) Throttle cable adjuster

(3) Lock nut

(A) Decrease freeplay

(B) Increase freeplay

SPARK ARRESTER

Refer to the Safety Precautions on page 48 .

The exhaust system spark arrester must be purged of accumulated carbon periodically (see Maintenance Schedule for servicing period, page 51).

The exhaust system becomes very hot during operation and remains hot for a period of time after stopping the engine. Allow the exhaust system to cool before performing this operation.

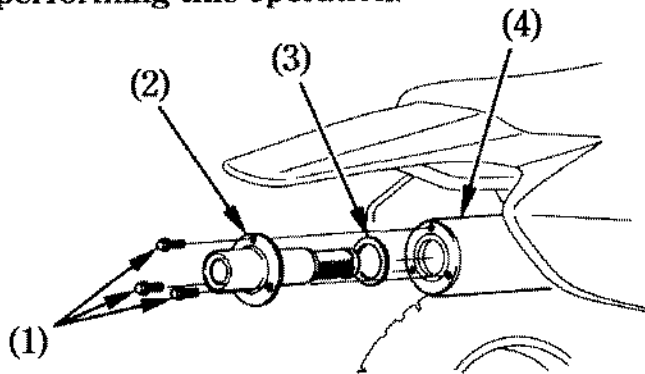

(1) Bolts
(2) Spark arrester

(3) Gasket
(4) Muffler

1. Remove the bolts (1), the spark arrester (2), and the gasket (3) from the muffler (4).
2. Use a brush to remove carbon deposits from the spark arrester screen (5). Be careful to avoid damaging the spark arrester screen. The spark arrester must be free of breaks and holes. Replace, if necessary. Check the gasket. Replace, if necessary.
3. Install the spark arrester and the gasket in the muffler and tighten the bolts securely.

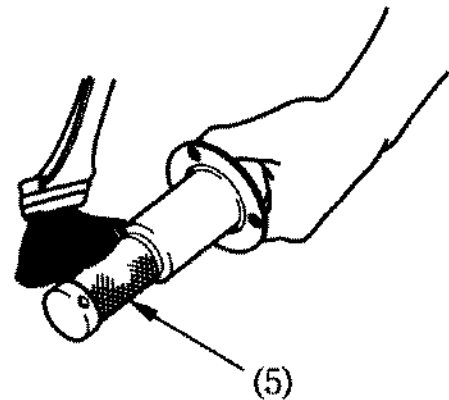

(5) Spark arrester screen

DRIVE CHAIN

Refer to the Safety Precautions on page 48 .

The service life of the drive chain is dependent upon proper lubrication and adjustment. Poor maintenance can cause premature wear or damage to the drive chain and sprockets.

The drive chain should be checked and lubricated as part of the Pre-ride Inspection (page 35). Under severe usage, or when the motorcycle is ridden in unusually dusty or muddy areas, more frequent maintenance will be necessary.

Inspection:

1. Turn the engine off, place the motorcycle on its side stand and shift the transmission into neutral.

2. Check slack in the lower drive chain run midway between the sprockets.

Drive chain slack should be adjusted to allow the following vertical movement by hand:

25 – 35 mm (1.0 – 1.4 in)

3. Roll the motorcycle forward. Stop. Check the drive chain slack. Repeat this procedure several times. Drive chain slack should remain constant. If the chain is slack only in certain sections, some links are kinked and binding. Binding and kinking can frequently be eliminated by lubrication.

NOTICE

Excessive chain slack may allow the drive chain to damage the engine cases.

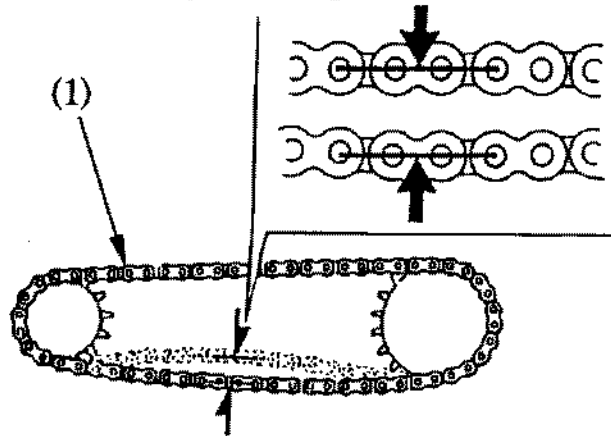

(1) Drive chain

4. Check the chain slider (2) for wear. If the depth of groove exceeds the limit, the chain slider must be replaced. See your Honda dealer.
Chain slider depth limit:
6 mm (0.2 in)

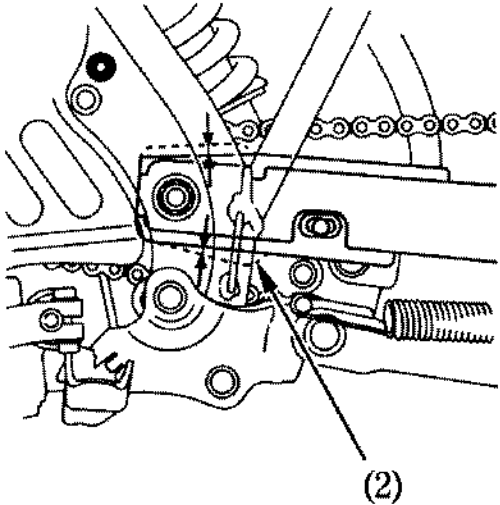

(2) Chain slider

5. Measure a section of the drive chain to determine whether the chain is worn beyond its service limit. Remove the drive chain and measure the distance between a span of pins from pin center to pin center. If the distance exceeds the service limit, the chain is worn out and should be replaced.

New Chain:
1,384 mm (54.5 in)

Service Limit:
1,412 mm (55.6 in)

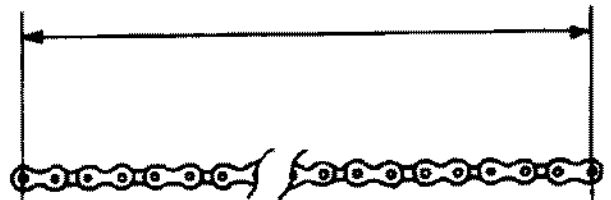

Measure a span of : 109 pins.

6. Inspect the sprocket teeth for possible wear or damage.

Damaged sprocket
Teeth

Worn sprocket
Teeth

Replace

Replace

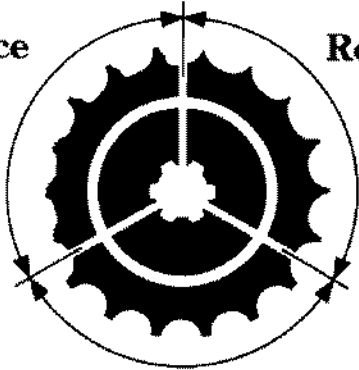

Normal sprocket Teeth

GOOD

If the drive chain or sprockets are excessively worn or damaged, they should be replaced. Never use a new chain with worn sprockets; rapid chain wear will result.

Adjustment:

If the drive chain requires adjustment, the procedure is as follows:

1. Place a support block under the engine to raise the rear wheel off the ground.
2. Loosen the rear axle nut (1).

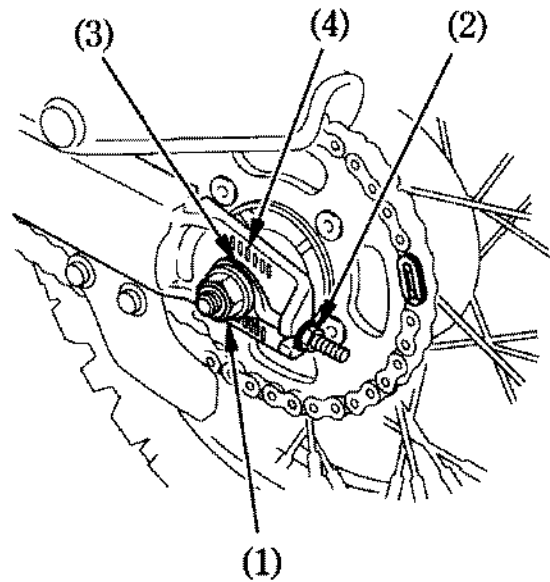

- (1) Rear axle nut
- (2) Adjusting nut

- (3) Adjuster index mark
- (4) Graduated scale

3. Turn the adjusting nut (2) on both the right and left chain adjusters an equal number of turns to increase or decrease chain slack.
Align the chain adjuster index marks (3) with the corresponding scale graduations (4) on both sides of the swingarm.

If the drive chain slack is excessive when the rear axle is moved to the furthest limit of adjustment, the drive chain is worn and must be replaced.

4. Tighten the rear axle nut to:
62 N·m (6.3 kgf·m , 46 lbf·ft)
5. Tighten the adjusting nuts.
6. Recheck drive chain slack.
7. Rear brake pedal freeplay is affected when repositioning the rear wheel to adjust drive chain slack. Check rear brake pedal freeplay and adjust as necessary (page 17).

If a torque wrench is not used for this installation, see your Honda dealer as soon as possible to verify proper assembly.

Lubrication:

Use SAE 80 or 90 gear oil or a commercially prepared drive chain lubricants in preference to motor oil or other lubricants. Saturate each chain link joint so that the lubricant penetrates between the link plates, pins, bushings, and rollers.

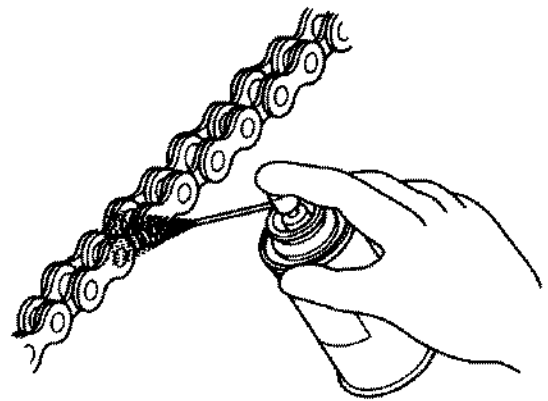

Removal and Cleaning:

When the drive chain becomes dirty, it should be removed and cleaned prior to lubrication.

1. With the engine off, carefully remove the master link retaining clip (1) with a pair of pliers. Do not bend or twist the clip. Remove the master link. Remove the drive chain from the motorcycle.
2. Clean the drive chain in high flash-point solvent and allow it to dry. Inspect the drive chain for possible wear or damage. Replace any chain that has damaged rollers, loose fitting links, or otherwise appears unserviceable.

Never use petrol or low flash point solvents for cleaning the drive chain. A fire or explosion could result.

3. Inspect the sprocket teeth for possible wear or damage.
4. Lubricate the drive chain (page 70).

5. Pass the chain over the sprockets and join the ends of the chain with the master link. For ease of assembly, hold the chain ends against adjacent rear sprocket teeth while inserting the master link.

The master link is the most critical part affecting the security of the drive chain. Master links are reusable, if they remain in excellent condition, but it is recommended that a new master link retaining clip be installed whenever the drive chain is reassembled.

Install the master link retaining clip so that the closed end of the clip will face the direction of forward wheel rotation.

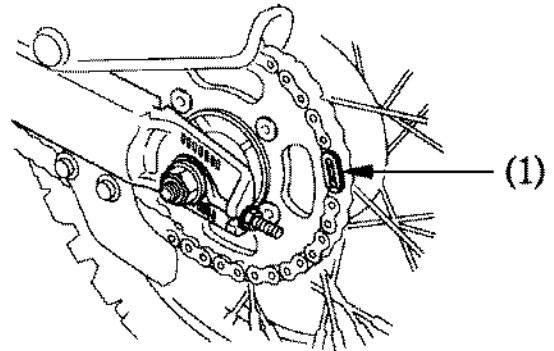

(1) Retaining clip

WHEEL RIMS AND SPOKES

Refer to the Safety Precautions on page 48 .

1. Inspect the wheel rims (1) and spokes (2) for damage.
2. Tighten any loose spokes and rim locks (3).
3. Check wheel rim runout. If runout is noticeable, see your Honda dealer for inspection.

Maintenance of spoke tension and wheel trueness are critical to safe motorcycle operation. During the first 150 km (100 miles), spokes will loosen more rapidly due to initial seating of parts. Excessively loose spokes may result in high speed instability and possible loss of control.

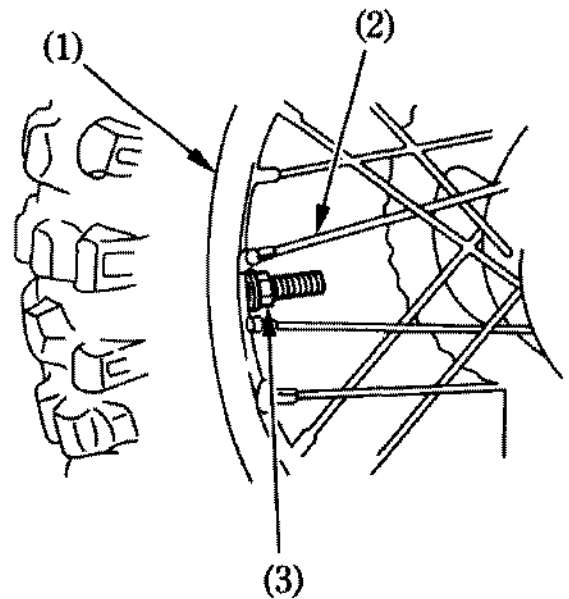

(1) Wheel rim
(2) Spoke

(3) Rim lock

WHEEL REMOVAL

Refer to the Safety Precautions on page 48 .

Front Wheel Removal

1. Raise the front wheel off the ground by placing a support block under the engine.
2. Loosen the cable guide bolt (1).
3. Disconnect the front brake cable (2) from the brake arm (3).
4. Remove the front axle nut (4) and front axle. The front wheel can now be removed.

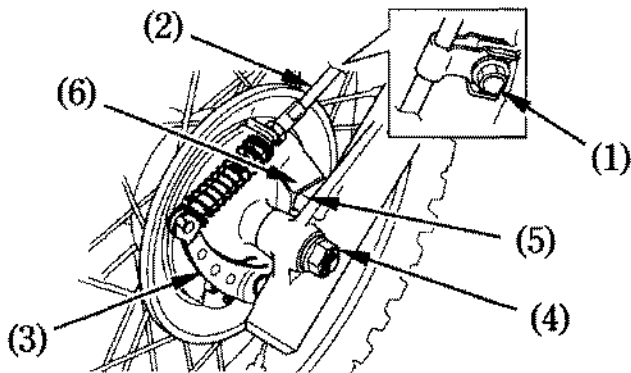

- | | |
|-----------------------|--------------------|
| (1) Cable guide bolt | (4) Front axle nut |
| (2) Front brake cable | (5) Lug |
| (3) Brake arm | (6) Slot |

Installation:

1. Reverse the removal procedure. Make sure that the lug (5) on the fork leg is located in the slot (6) in the brake panel. Be sure to tighten the front axle nut to:
62 N·m (6.3 kgf·m , 46 lbf·ft)
2. Check front brake adjustment.
3. After installing the wheel, apply the brake several times and then check if the wheel rotates freely. Recheck the wheel if the brake drags or if the wheel does not rotate freely.

If a torque wrench was not used for installation, see your Honda dealer as soon as possible to verify proper assembly. Improper assembly may lead to loss of braking capacity.

Rear Wheel Removal

1. Raise the rear wheel off the ground by placing a support block under the engine.
2. Remove the rear brake adjuster (1).
3. Press and release the rear brake pedal and disconnect the brake rod (2) from the brake arm (3).
4. Loosen the adjusting nut (4) on the chain adjuster on both sides.

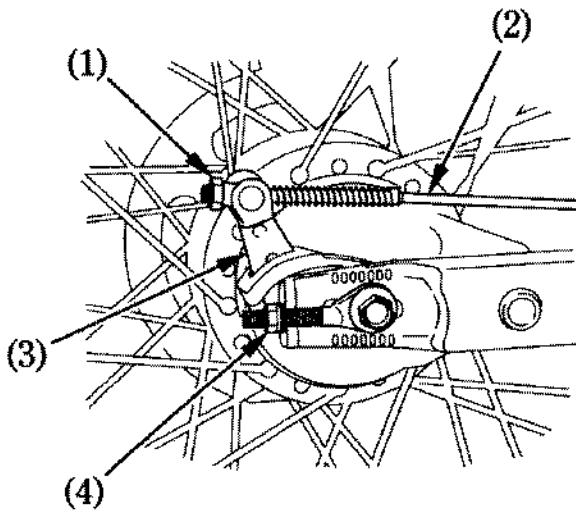

(1) Brake adjuster
(2) Brake rod

(3) Brake arm
(4) Adjusting nut

74

5. Unscrew the rear axle nut (5) and pull out the axle. Push the wheel forward and derail the drive chain from the rear sprocket. Tilt the motorcycle to one side so that the wheel can be removed.

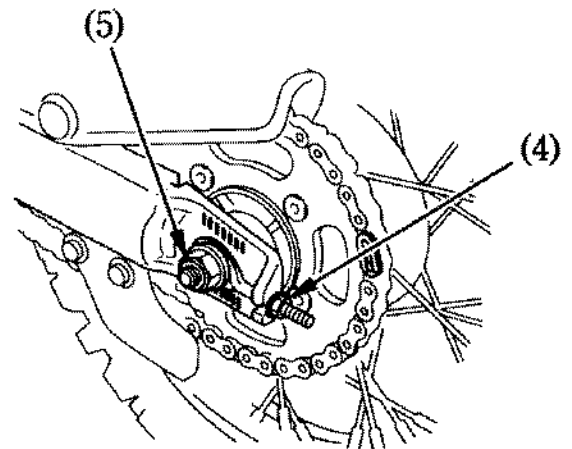

(5) Rear axle nut

Installation:

1. Reverse the removal procedure. Make sure that the lug (6) on the swingarm is located in the slot (7) in the brake panel. Be sure to tighten the rear axle nut to:
62 N·m (6.3 kgf·m , 46 lbf·ft)
2. Adjust the drive chain (pages 69 – 70).
3. Adjust the brake (page 17).
4. Apply the brake several times and check for free wheel rotation after the brake pedal is released.

If a torque wrench was not used for installation, see your Honda dealer as soon as possible to verify proper assembly. Improper assembly may lead to loss of braking capacity.

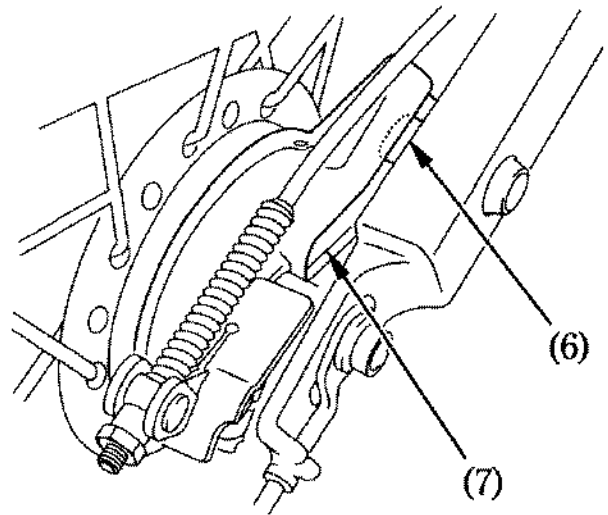

(6) Lug

(7) Slot

BRAKE SHOE WEAR

Refer to the Safety Precautions on page 48 .

The front and rear brakes are equipped with brake wear indicators.

When the brake is applied, an arrow (1) attached to the brake arm (2) moves toward a reference mark (3) on the brake panel (4). If the arrow aligns with the reference mark on full application of the brake, the brake shoes must be replaced. See your Honda dealer for this service.

When the brake service is necessary, see your Honda dealer. Use only Honda Genuine Parts or its equivalent.

< FRONT BRAKE >

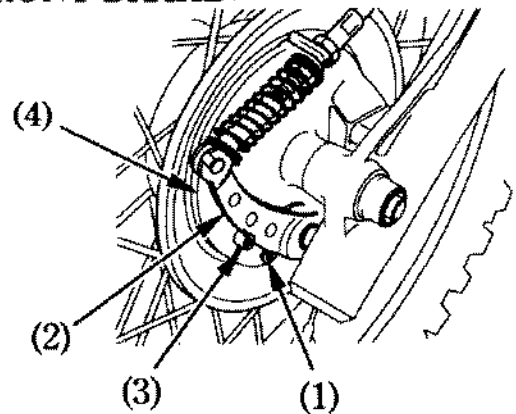

< REAR BRAKE >

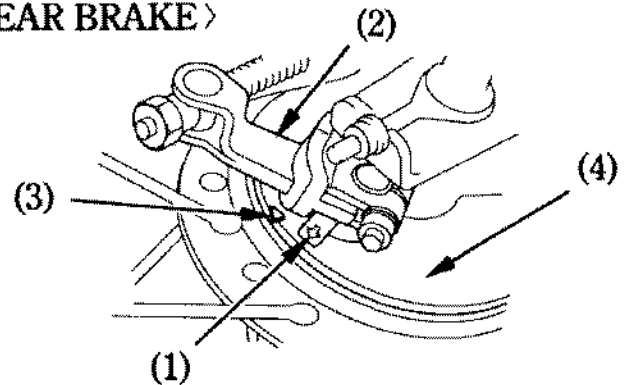

- | | |
|---------------|--------------------|
| (1) Arrow | (3) Reference mark |
| (2) Brake arm | (4) Brake panel |

FRONT SUSPENSION

Refer to the Safety Precautions on page 48 .

Check the fork operation by locking the front brake and pumping the forks up and down several times. The suspension should function smoothly, with no oil leakage from the fork legs. Damaged, binding, or leaking fork should be repaired before the motorcycle is operated. Check security of all fork and handlebar mounting bolts (1).

Operating the motorcycle with loose, worn, or damaged steering or front suspension components may adversely affect vehicle handling and stability.

If any suspension components appear worn or damaged, consult your Honda dealer for further inspection. The suspension components are directly related to safety and your Honda dealer is qualified to determine whether or not replacement parts or repairs are needed.

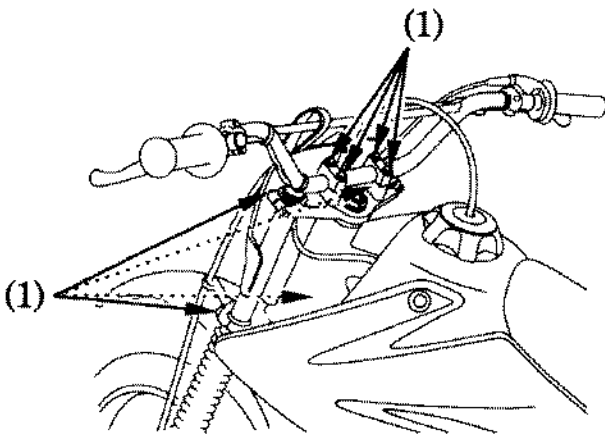

(1) Mounting bolts

REAR SUSPENSION

Refer to the Safety Precautions on page 48.

Check the rear suspension periodically by careful visual examination. Note the following items:

1. Swingarm bushings (1) should be checked by pushing hard against the side of the rear wheel while the motorcycle is on a support block and feeling for looseness of the bushings.
2. Check all suspension component attachment points (2) for security of their fasteners.
3. Check for oil leaks in the shock absorber units.

If any suspension components appear worn or damaged, consult your Honda dealer for further inspection. The suspension components are directly related to safety and your Honda dealer is qualified to determine whether or not replacement parts or repairs are needed.

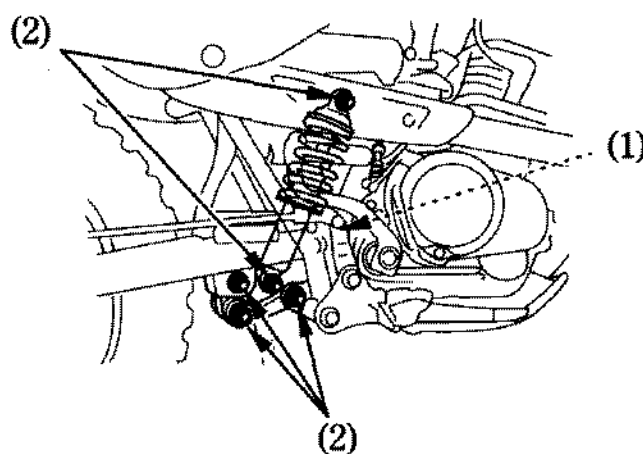
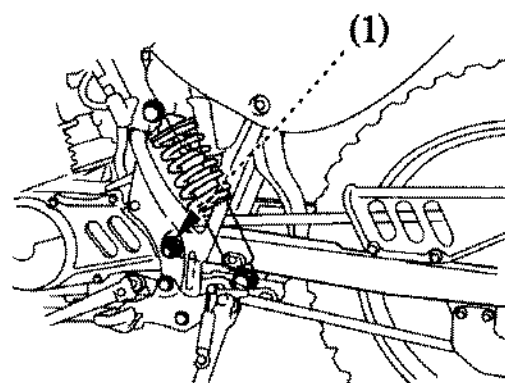

- (1) Swingarm bushings
(2) Attachment points

SIDE STAND

Refer to the Safety Precautions on page 48 .

Check the side stand spring (1) for damage and loss of tension, and the side stand assembly for freedom of movement.

If the side stand is squeaky or stiff, clean the pivot area and lubricate the pivot bolt with clean engine oil.

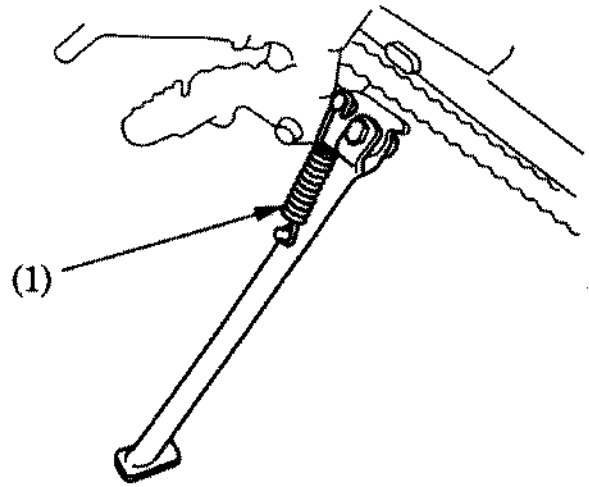

(1) Side stand spring

CLEANING

Clean your motorcycle regularly to protect the surface finishes and inspect for damage, wear and oil leakage.

Avoid cleaning products that are not specifically designed for motorcycle or automobile surfaces.

They may contain harsh detergents or chemical solvents that could damage the metal, paint, and plastic on your motorcycle.

If your motorcycle is still warm from recent operation, give the engine and exhaust system time to cool off.

We recommend avoiding the use of high pressure water spray (typical in coin-operated car washes).

NOTICE

High pressure water (or air) can damage certain parts of the motorcycle.

High pressure washer spray can damage certain parts of your motorcycle. If you use a high pressure washer, avoid spraying the following areas:

- Wheel Hubs
- Muffler Outlet
- Under Seat
- Engine Stop Button
- Under Fuel Tank
- Drive Chain
- Carburetor
- Ignition Switch

Washing the Motorcycle

1. Rinse the motorcycle thoroughly with cool water to remove loose dirt.
2. Clean the motorcycle with a sponge or soft cloth using cool water.
Avoid directing water to muffler outlets and electrical parts.
3. Clean the plastic parts using a cloth or sponge dampened with a solution of mild detergent and water. Rub the soiled area gently rinsing it frequently with fresh water.
Take care to keep brake fluid or chemical solvents off the motorcycle.
They will damage the plastic and painted surfaces.
4. After cleaning, rinse the motorcycle thoroughly with plenty of clean water. Strong detergent residue can corrode alloy parts.
5. Dry the motorcycle, start the engine, and let it run for several minutes.

6. Test the brakes before riding the motorcycle. Several applications may be necessary to restore normal braking performance.
7. Lubricate the drive chain immediately after washing and drying the motorcycle.

Braking efficiency may be temporarily impaired immediately after washing the motorcycle.

Anticipate longer stopping distance to avoid a possible accident.

Finishing Touches

After washing your motorcycle, consider using a commercially-available spray cleaner/polish or quality liquid or paste wax to finish the job. Use only a non-abrasive polish or wax made specifically for motorcycles or automobiles. Apply the polish or wax according to the instructions on the container.

STORAGE GUIDE

Extended storage, such as for winter, requires that you take certain steps to reduce the effects of deterioration from non-use of the motorcycle. In addition, necessary repairs should be made **BEFORE** storing the motorcycle; otherwise, these repairs may be forgotten by the time the motorcycle is removed from storage.

STORAGE

1. Change the engine oil and clean the filter screen.
2. Drain the fuel tank and carburetor into an approved petrol container.
Reinstall the fuel fill cap on the tank.

To assure proper performance after storage lasting more than one month, it is important to drain the carburetor.

WARNING

Petrol is highly flammable and explosive. You can be burned or seriously injured when handling fuel.

- Stop the engine and keep heat, sparks, and flame away.
- Refuel only outdoors.
- Wipe up spills immediately.

3. To prevent rusting in the cylinder, perform the following:
 - Remove the spark plug cap from the spark plug. Using tape or string, secure the cap to any convenient plastic body part so that it is positioned away from the spark plug.
 - Remove the spark plug from the engine and store it in a safe place. Do not connect the spark plug to the spark plug cap.
 - Pour a tablespoon (15–20 cm³) of clean engine oil into the cylinder and cover the spark plug hole with a piece of cloth.
 - Crank the engine several times to distribute the oil.
 - Reinstall the spark plug and spark plug cap.
4. Wash and dry the motorcycle. Wax all painted surfaces. Coat chrome with rustinhibiting oil.
5. Lubricate the drive chain (page 70).
6. Inflate the tyres to their recommended pressures. Place the motorcycle on blocks to raise both tyres off the ground.
7. Cover the motorcycle (don't use plastic or other coated materials) and store in an unheated area, free of dampness with a minimum of daily temperature variation. Do not store the motorcycle in direct sunlight.

REMOVAL FROM STORAGE

1. Uncover and clean the motorcycle.
Change the engine oil if more than 4 months have passed since the start of storage.
2. Perform all Pre-ride Inspection checks (page 35).
3. Test ride the motorcycle at low speeds in a safe riding area away from traffic.

TAKING CARE OF THE UNEXPECTED

IF YOU CRASH

Personal safety is your first priority after a crash. If you or anyone else has been injured, take time to assess the severity of the injuries and whether it is safe to continue riding. If you cannot ride safely, send someone for help. Do not ride if you will risk further injury.

If you decide that you are capable of riding safely, first evaluate the condition of your motorcycle. If the engine is still running, turn it off and look it over carefully; inspect it for fluid leaks, check the tightness of critical nuts and bolts, and secure such parts as the handlebar, control levers, brakes, and wheels.

If there is minor damage, or you are unsure about possible damage, ride slowly and cautiously. Sometimes, crash damage is hidden or not immediately apparent, so you should have your motorcycle thoroughly checked at a qualified service facility as soon as possible. Also, be sure to have your Honda dealer check the frame and suspension after any serious crash.

SPECIFICATIONS

DIMENSIONS

Overall length	1,749 mm (68.9 in)
Overall width	727 mm (28.6 in)
Overall height	995 mm (39.2 in)
Wheelbase	1,209 mm (47.6 in)

CAPACITIES

Engine oil	After draining	0.9 ℓ (1.0 US qt , 0.8 Imp qt)
	After disassembly	1.1 ℓ (1.2 US qt , 1.0 Imp qt)
Fuel tank		5.0 ℓ (1.32 US gal , 1.10 Imp gal)
Fuel reserve		0.7 ℓ (0.18 US gal , 0.15 Imp gal)
Passenger capacity		Operator only; no passenger
Maximum weight capacity		100 kg (220 lbs)

ENGINE

Bore and stroke	47.5 × 45 mm (1.87 × 1.77 in)
Compression ratio	9.7:1
Displacement	79.7 cm ³ (4.86 cu-in)
Spark plug	
Standard	CR7HSA (NGK) or U22FSR-U (DENSO)
For cold climate (Below 5°C, 41°F)	CR6HSA (NGK) or U20FSR-U (DENSO)
For extended high speed riding	CR8HSA (NGK) or U24FSR-U (DENSO)
Spark plug gap	0.6–0.7 mm (0.02–0.03 in)
Valve clearance (Cold)	Intake 0.05 mm (0.002 in) Exhaust 0.05 mm (0.002 in)
Idle speed	1,500 ± 100 min ⁻¹ (rpm)

CHASSIS AND SUSPENSION

Caster	28°02'
Trail	74 mm (2.9 in)
Tyre size, front	2.50—16 4PR
Tyre size, rear	3.60—14 4PR
Tyre type	bias-ply, tube

POWER TRANSMISSION

Primary reduction	4.437
Gear ratio, 1st	2.692
2nd	1.823
3rd	1.400
4th	1.130
5th	0.960
Final reduction	3.285

