

OWNER'S MANUAL 2014

FC 250 EU

Art. no. 3402002en



THE PIONEERS OF MOTOCROSS

Husqvarna[®]
MOTORCYCLES

DEAR HUSQVARNA CUSTOMER

Congratulations on your decision to purchase a Husqvarna motorcycle. You are now the owner of a state-of-the-art sports motorcycle that will give you enormous pleasure if you service and maintain it accordingly.

We wish you a lot of enjoyment in riding this vehicle.

Enter the serial numbers of your vehicle below.

Chassis number (☛ p. 10)	Dealer's stamp
Engine number (☛ p. 10)	

The Owner's Manual contained the latest information for this model series at the time of going to print. Slight deviations resulting from continuing development and design can, however, not be completely excluded.

All specifications are non-binding. Husqvarna Motorcycles GmbH specifically reserves the right to modify or delete technical specifications, prices, colors, forms, materials, services, designs, equipment, etc., without prior notice and without specifying reasons, to adapt these to local conditions, as well as to stop production of a particular model without prior notice. Husqvarna accepts no liability for delivery options, deviations from illustrations and descriptions, as well as misprints and other errors. The models portrayed partly contain special equipment that does not belong to the regular scope of supply.

© 2013 Husqvarna Motorcycles GmbH, Mattighofen Austria

All rights reserved

Reproduction, even in part, as well as copying of all kinds, is permitted only with the express written permission of the copyright owner.















REG.NO. 12 100 6061





























ISO 9001(12 100 6061)

Husqvarna applies quality assurance processes that lead to the highest possible product quality as defined in the ISO 9001 international quality management standard.

Issued by: TÜV Management Service





Husqvarna Motorcycles GmbH
5230 Mattighofen, Austria

1	MEANS OF REPRESENTATION	4	8	RIDING INSTRUCTIONS.....	20
	1.1 Symbols used	4	8.1	Checks and maintenance before putting into operation	20
	1.2 Formats used.....	4	8.2	Starting.....	20
2	SAFETY ADVICE	5	8.3	Starting off	21
	2.1 Use definition - intended use.....	5	8.4	Shifting, riding	21
	2.2 Safety advice	5	8.5	Applying the brakes	21
	2.3 Degrees of risk and symbols	5	8.6	Stopping, parking.....	21
	2.4 Tampering warning	5	8.7	Transport	22
	2.5 Safe operation.....	5	8.8	Refueling.....	22
	2.6 Protective clothing	6	9	SERVICE SCHEDULE.....	24
	2.7 Work rules.....	6	9.1	Service schedule.....	24
	2.8 Environment.....	6	9.2	Service work (as additional order).....	25
	2.9 Owner's Manual.....	6	10	TUNING THE CHASSIS	26
3	IMPORTANT INFORMATION	7	10.1	Checking the basic chassis setting with the rider's weight	26
	3.1 Manufacturer and implied warranty	7	10.2	Compression damping of the shock absorber.....	26
	3.2 Operating and auxiliary substances	7	10.3	Adjusting the low-speed compression damping of the shock absorber	26
	3.3 Spare parts, accessories.....	7	10.4	Adjusting the high-speed compression damping of the shock absorber	27
	3.4 Service.....	7	10.5	Adjusting the rebound damping of the shock absorber	27
	3.5 Figures.....	7	10.6	Measuring rear wheel sag unloaded.....	28
	3.6 Customer service	7	10.7	Checking the static sag of the shock absorber.....	28
4	VIEW OF VEHICLE	8	10.8	Checking the riding sag of the shock absorber.....	28
	4.1 View of vehicle, front left side (example).....	8	10.9	Adjusting the spring preload of the shock absorber 	29
	4.2 View of vehicle, rear right side (example)	9	10.10	Adjusting the riding sag 	29
5	SERIAL NUMBERS.....	10	10.11	Checking the basic setting of the fork	30
	5.1 Chassis number	10	10.12	Adjusting the compression damping of the fork....	30
	5.2 Type label	10	10.13	Adjusting the rebound damping of the fork.....	30
	5.3 Engine number.....	10	10.14	Handlebar position	31
	5.4 Fork part number	10	10.15	Adjusting the handlebar position 	31
	5.5 Shock absorber part number	10	11	SERVICE WORK ON THE CHASSIS.....	32
6	CONTROLS.....	11	11.1	Raising the motorcycle with the lift stand.....	32
	6.1 Clutch lever.....	11	11.2	Removing the motorcycle from the lift stand.....	32
	6.2 Hand brake lever.....	11	11.3	Bleeding the fork legs.....	32
	6.3 Throttle grip	11	11.4	Cleaning the dust boots of the fork legs	33
	6.4 Kill switch.....	11	11.5	Loosening the fork protection.....	33
	6.5 Electric starter button.....	11	11.6	Positioning the fork protection.....	33
	6.6 Map-Select switch for the basic setting.....	12	11.7	Removing the fork legs 	33
	6.7 Map-Select switch for vehicle operation	12	11.8	Installing the fork legs 	34
	6.8 Overview of indicator lamps	12	11.9	Removing the fork protector 	35
	6.9 Opening the filler cap	12	11.10	Installing the fork protector 	35
	6.10 Closing the filler cap.....	13	11.11	Removing the lower triple clamp 	35
	6.11 Cold start button.....	13	11.12	Installing the lower triple clamp 	36
	6.12 Idle speed adjusting screw.....	14	11.13	Checking the steering head bearing play.....	37
	6.13 Shift lever	14	11.14	Adjusting the play of the steering head bearing 	38
	6.14 Foot brake lever	14	11.15	Greasing the steering head bearing 	38
	6.15 Plug-in stand.....	15	11.16	Removing the start number plate	38
7	PREPARING FOR USE.....	16	11.17	Installing the start number plate.....	39
	7.1 Advice on first use.....	16	11.18	Removing the front fender.....	39
	7.2 Running in the engine.....	17	11.19	Installing the front fender	39
	7.3 Preparing the vehicle for difficult operating conditions	17	11.20	Removing the shock absorber 	40
	7.4 Preparing for rides on dry sand	17	11.21	Installing the shock absorber 	41
	7.5 Preparing for rides on wet sand	18	11.22	Removing the seat	42
	7.6 Preparing for rides on wet and muddy surfaces ...	18	11.23	Mounting the seat	42
	7.7 Preparing for rides at high temperatures and low speeds.....	19	11.24	Removing the air filter box lid	42
	7.8 Preparing for rides at low temperatures or in snow.....	19			

11.25	Installing the air filter box lid.....	42	15.2	Checking the antifreeze and coolant level.....	71
11.26	Removing the air filter 	43	15.3	Checking the coolant level	72
11.27	Installing the air filter 	43	15.4	Draining the coolant 	72
11.28	Cleaning the air filter and air filter box 	43	15.5	Refilling coolant 	73
11.29	Sealing the air filter box 	44	16	TUNING THE ENGINE	74
11.30	Removing the main silencer	44	16.1	Checking the play in the throttle cable.....	74
11.31	Installing the main silencer.....	44	16.2	Adjusting the play in the throttle cable 	74
11.32	Changing the glass fiber yarn filling of the main silencer 	45	16.3	Adjusting the idle speed 	75
11.33	Removing the right side cover	45	16.4	Checking the basic position of the shift lever	75
11.34	Installing the right side cover	46	16.5	Adjusting the basic position of the shift lever  ...	75
11.35	Removing the fuel tank 	46	17	SERVICE WORK ON THE ENGINE.....	76
11.36	Installing the fuel tank 	47	17.1	Changing the fuel screen 	76
11.37	Checking for chain dirt accumulation.....	48	17.2	Checking the engine oil level	76
11.38	Cleaning the chain	48	17.3	Changing the engine oil and oil filter, cleaning the oil screen 	77
11.39	Checking the chain tension	49	17.4	Adding engine oil	79
11.40	Adjusting the chain tension	49	18	CLEANING, CARE.....	80
11.41	Checking the chain, rear sprocket, engine sprocket and chain guide.....	50	18.1	Cleaning the motorcycle.....	80
11.42	Checking the frame 	51	19	STORAGE	81
11.43	Checking the swingarm 	52	19.1	Storage.....	81
11.44	Checking the throttle cable routing.....	52	19.2	Putting into operation after storage	81
11.45	Checking the rubber grip.....	52	20	TROUBLESHOOTING	82
11.46	Additionally securing the rubber grip	53	21	BLINK CODE.....	84
11.47	Adjusting the basic position of the clutch lever	53	22	TECHNICAL DATA	85
11.48	Checking/rectifying the fluid level of the hydraulic clutch.....	53	22.1	Engine.....	85
11.49	Changing the hydraulic clutch fluid 	53	22.2	Engine tightening torques.....	85
12	BRAKE SYSTEM	55	22.3	Capacities.....	87
12.1	Checking the free travel of the hand brake lever.....	55	22.3.1	Engine oil.....	87
12.2	Adjusting the basic position of the hand brake lever	55	22.3.2	Coolant	87
12.3	Checking the brake discs.....	55	22.3.3	Fuel	87
12.4	Checking the front brake fluid level.....	56	22.4	Chassis.....	87
12.5	Adding front brake fluid 	56	22.5	Electrical system	88
12.6	Checking the front brake linings	57	22.6	Tires.....	88
12.7	Changing the front brake linings 	57	22.7	Fork	88
12.8	Checking the free travel of foot brake lever.....	59	22.8	Shock absorber	88
12.9	Adjusting the basic position of the foot brake lever 	59	22.9	Chassis tightening torques	89
12.10	Checking the rear brake fluid level.....	60	23	SUBSTANCES	91
12.11	Adding rear brake fluid 	60	24	AUXILIARY SUBSTANCES	93
12.12	Checking the rear brake linings	61	25	STANDARDS.....	94
12.13	Changing the rear brake linings 	62	INDEX.....		95
13	WHEELS, TIRES.....	64			
13.1	Removing the front wheel 	64			
13.2	Installing the front wheel 	64			
13.3	Removing the rear wheel 	65			
13.4	Installing the rear wheel 	65			
13.5	Checking the tire condition.....	66			
13.6	Checking the tire air pressure.....	67			
13.7	Checking the spoke tension	67			
14	ELECTRICAL SYSTEM.....	68			
14.1	Removing the battery 	68			
14.2	Installing the battery 	68			
14.3	Recharging the battery 	69			
14.4	Changing the main fuse	70			
15	COOLING SYSTEM.....	71			
15.1	Cooling system	71			

1.1 Symbols used

The symbols used are explained in the following.

-
- | | |
|--|--|
|  | Identifies an expected reaction (e.g. to a work step or a function). |
|  | Identifies an unexpected reaction (e.g. to a work step or a function). |
|  | All work marked with this symbol requires specialist knowledge and technical understanding. In the interest of your own safety, have these jobs performed by an authorized Husqvarna workshop. There, your motorcycle will be optimally cared for by specially trained experts using the special tools required. |
|  | Identifies a page reference (more information is provided on the specified page). |
-

1.2 Formats used

The following typographical formats are used.

-
- | | |
|--------------------------|--|
| Specific name | Identifies a proprietary name. |
| Name[®] | Identifies a protected name. |
| Brand[™] | Identifies a brand available on the open market. |
-

2.1 Use definition - intended use

Husqvarna sport motorcycles are designed and built to withstand the normal stresses and strains of competitive use. The motorcycles comply with currently valid regulations and categories of the top international motorsport organizations.



Info

The motorcycle may only be used in closed off areas remote from public road traffic.

2.2 Safety advice

A number of safety instructions need to be followed to operate the vehicle safely. Therefore, read this manual carefully. The safety instructions are highlighted in the text and are referred to at the relevant passages.



Info

The vehicle has various information and warning labels at prominent locations. Do not remove information/warning labels. If they are missing, you or others may not recognize dangers and may therefore be injured.

2.3 Degrees of risk and symbols



Danger

Identifies a danger that will immediately and invariably lead to fatal or serious permanent injury if the appropriate measures are not taken.



Warning

Identifies a danger that is likely to lead to fatal or serious injury if the appropriate measures are not taken.



Caution

Identifies a danger that may lead to minor injuries if the appropriate measures are not taken.

Note

Identifies a danger that will lead to considerable machine and material damage if the appropriate measures are not taken.



Warning

Identifies a danger that will lead to environmental damage if the appropriate measures are not taken.

2.4 Tampering warning

Tampering with the noise control system is prohibited. Federal law prohibits the following acts or the causing thereof:

- 1 The removal or rendering inoperative by any person other than for purposes of maintenance, repair, or replacement, of any device or element of design incorporated into any new vehicle for the purpose of noise control prior to its sale or delivery to the ultimate purchaser or while it is in use, or
- 2 the use of the vehicle after such device or element of design has been removed or rendered inoperative by any person.

Among those acts presumed to constitute tampering are the acts listed below:

- 1 Removal or puncturing of the main silencer, baffles, header pipes or any other components which conduct exhaust gases.
- 2 Removal or puncturing of parts of the intake system.
- 3 Lack of proper maintenance.
- 4 Replacing moving part of the vehicle, or parts of the exhaust or intake system, with parts other than those specified by the manufacturer.

2.5 Safe operation



Danger

Danger of accidents Danger arising from the rider's judgement being impaired.

- Do not operate the vehicle while under the influence of alcohol, drugs and certain medications or physically or mentally impaired.



Danger

Danger of poisoning Exhaust gases are toxic and inhaling them may result in unconsciousness and/or death.

- When running the engine, always make sure there is sufficient ventilation, and do not start or run the engine in an enclosed space without an effective exhaust extraction system.



Warning

Danger of burns Some vehicle components become very hot when the vehicle is operated.

- Do not touch hot components such as exhaust system, radiator, engine, shock absorber, and the brake system. Allow these components to cool down before starting work on them.

Only operate the vehicle when it is in perfect technical condition, in accordance with its intended use, and in a safe and environmentally compatible manner.

The vehicle should only be used by trained persons.

Have malfunctions that impair safety promptly eliminated by an authorized Husqvarna workshop.

Adhere to the information and warning labels on the vehicle.

2.6 Protective clothing



Warning

Risk of injury Missing or poor protective clothing presents an increased safety risk.

- Wear protective clothing (helmet, boots, gloves, pants and jacket with protectors) every time you ride the vehicle. Always wear protective clothing that is in good condition and meets the legal requirements.

In the interest of your own safety, Husqvarna recommends that you only operate the vehicle while wearing protective clothing.

2.7 Work rules

Special tools are necessary for certain tasks. The tools are not contained in the vehicle but can be ordered under the number in parentheses. E.g.: bearing puller (15112017000)

During assembly, non-reusable parts (e.g. self-locking screws and nuts, seals and seal rings, O-rings, pins, lock washers) must be replaced by new parts.

In some instances, a thread locker (e.g. **Loctite**[®]) is required. The manufacturer instructions for use must be followed.

After disassembly, clean the parts that are to be reused and check them for damage and wear. Change damaged or worn parts.

After you complete the repair or service work, check the operating safety of the vehicle.

2.8 Environment

If you use your motorcycle responsibly, you can ensure that problems and conflicts do not occur. To protect the future of the motorcycle sport, make sure that you use your motorcycle legally, display environmental consciousness, and respect the rights of others.

When disposing of used oil, other operating and auxiliary fluids, and used components, comply with the laws and regulations of the respective country.

Because motorcycles are not subject to the EU regulations governing the disposal of used vehicles, there are no legal regulations that pertain to the disposal of an end-of-life motorcycle. Your authorized Husqvarna dealer will be glad to advise you.

2.9 Owner's Manual

It is important that you read this Owner's Manual carefully and completely before making your first trip. The Owner's Manual contains useful information and many tips on how to operate, handle, and maintain your motorcycle. Only then will you find out how to customize the vehicle ideally for your own use and how you can protect yourself from injury.

Keep the Owner's Manual in an accessible place to enable you to refer to it as needed.

If you would like to know more about the vehicle or have questions on the material you read, please contact an authorized Husqvarna dealer.

The Owner's Manual is an important component of the vehicle and should be handed over to the new owner if the vehicle is sold.

3.1 Manufacturer and implied warranty

The work prescribed in the service schedule must be carried out by an authorized Husqvarna workshop only and confirmed in the customer's service & warranty booklet and in the **Husqvarna dealer.net**; otherwise, all warranty claims will be void. No warranty claims can be considered for damage resulting from manipulations and/or alterations to the vehicle.

Additional information on the manufacturer or implied warranty and the procedures involved can be found in the service & warranty booklet.

3.2 Operating and auxiliary substances



Warning

Environmental hazard Improper handling of fuel is a danger to the environment.

- Do not allow fuel to get into the ground water, the ground, or the sewage system.

Use operating and auxiliary substances (such as fuel and lubricants) as specified in the Owner's Manual.

3.3 Spare parts, accessories

For your own safety, only use spare parts and accessory products that are approved and/or recommended by Husqvarna and have them installed by an authorized Husqvarna workshop. Husqvarna accepts no liability for other products and any resulting damage or loss.

Certain spare parts and accessory products are specified in parentheses in the descriptions. Your authorized Husqvarna dealer will be glad to advise you.

The current **Husky Power** parts for your vehicle can be found on the Husqvarna website.

International Husqvarna website: www.husqvarna-motorcycles.com

3.4 Service

A prerequisite for perfect operation and prevention of premature wear is that the service, care, and tuning work on the engine and chassis is properly carried out as described in the Owner's Manual. Incorrect adjustment and tuning of the engine and chassis can lead to damage and breakage of components.

Use of the vehicle under difficult conditions, such as on sand or on wet and muddy surfaces, can lead to considerably more rapid wear of components such as the drive train, brake system, or suspension components. For this reason, it may be necessary to inspect or replace parts before the next scheduled service.

It is imperative that you adhere to the stipulated run-in times and service intervals. If you observe these exactly, you will ensure a much longer service life for your motorcycle.

3.5 Figures

The figures contained in the manual may depict special equipment.

In the interest of clarity, some components may be shown disassembled or may not be shown at all. It is not always necessary to disassemble the component to perform the activity in question. Please follow the instructions in the text.

3.6 Customer service

Your authorized Husqvarna dealer will be happy to answer any questions you may have on your vehicle and Husqvarna.

A list of authorized Husqvarna dealers can be found on the Husqvarna website.

International Husqvarna website: www.husqvarna-motorcycles.com

4.1 View of vehicle, front left side (example)



B01821-10

- | | |
|---|-----------------------------|
| 1 | Hand brake lever (☛ p. 11) |
| 2 | Clutch lever (☛ p. 11) |
| 3 | Filler cap |
| 4 | Fork rebound setting |
| 5 | Cold start button (☛ p. 13) |
| 6 | Shift lever (☛ p. 14) |
| 7 | Air filter box lid |
| 8 | Plug-in stand (☛ p. 15) |

4.2 View of vehicle, rear right side (example)



B01822-10

1	Kill switch (☛ p. 11)
2	Electric starter button (☛ p. 11)
3	Throttle grip (☛ p. 11)
4	Fork compression adjustment
5	Shock absorber rebound adjustment
6	Level viewer for brake fluid, rear
7	Shock absorber compression adjustment
8	Level viewer, engine oil
9	Foot brake lever (☛ p. 14)

5.1 Chassis number

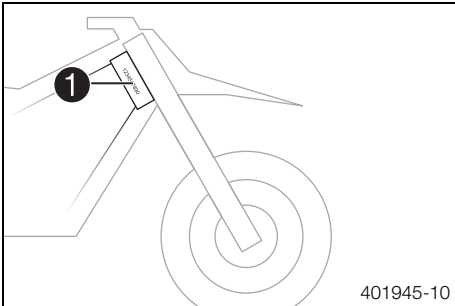

The chassis number ❶ is stamped on the right side of the steering head.

5.2 Type label

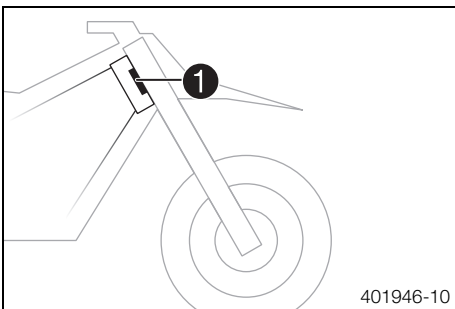

The type label ❶ is fixed to the front of the steering head.

5.3 Engine number

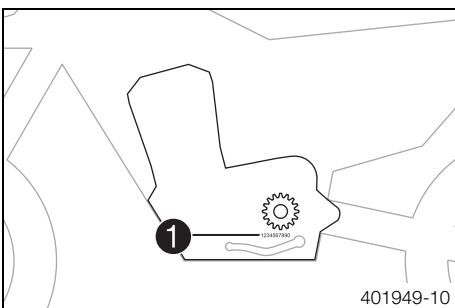

The engine number ❶ is stamped on the left side of the engine under the engine sprocket.

5.4 Fork part number

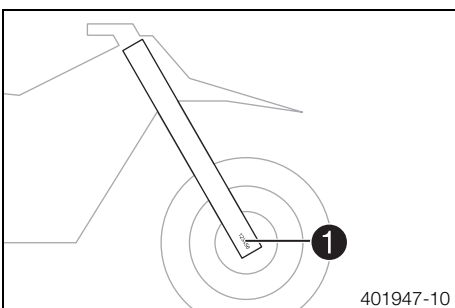

The fork part number ❶ is stamped on the inner side of the axle clamp.

5.5 Shock absorber part number

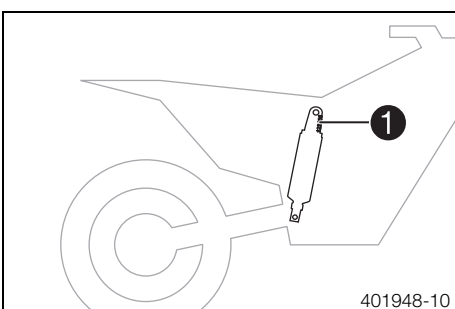

The shock absorber part number ❶ is stamped on the top of the shock absorber above the adjusting ring on the engine side.

6.1 Clutch lever

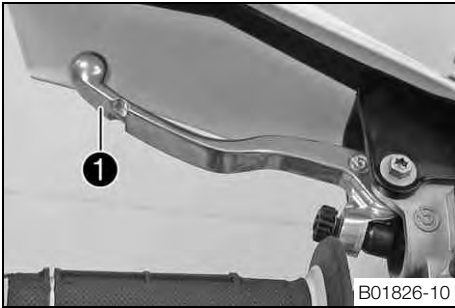

The clutch lever ❶ is fitted on the left side of the handlebar. The clutch is hydraulically operated and self-adjusting.

6.2 Hand brake lever

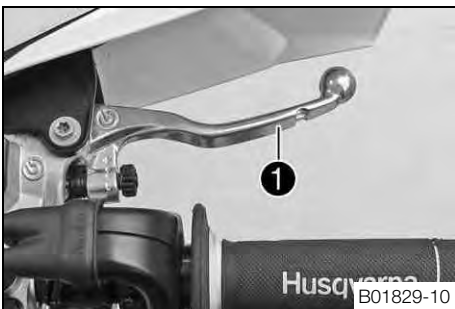

Hand brake lever ❶ is located on the right side of the handlebar. The hand brake lever is used to activate the front brake.

6.3 Throttle grip



The throttle grip ❶ is fitted on the right side of the handlebar.

6.4 Kill switch



Kill switch ❶ is fitted on the left side of the handlebar.

Possible states

- Kill switch ☒ in the basic position – In this position, the ignition circuit is closed and the engine can be started.
- Kill switch ☒ pressed – In this position, the ignition circuit is interrupted, a running engine stops, and a non-running engine will not start.

6.5 Electric starter button



The electric starter button ❶ is fitted on the right side of the handlebar.

Possible states

- Electric starter button ③ in basic position
- Electric starter button ③ pressed – In this position, the electric starter is actuated.

6.6 Map-Select switch for the basic setting

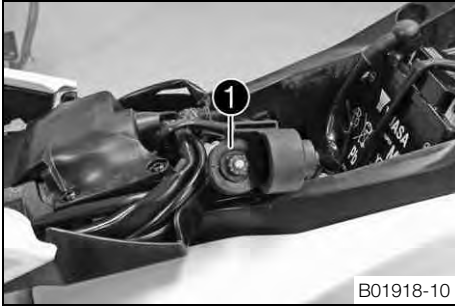

B01918-10

The **Map-Select** switch for the basic setting ❶ is fitted under the seat.

Possible states

1	Soft – The mapping with reduced peak performance for better rideability is activated.
2	ADVANCED – The mapping for performance with a very direct response is activated.
3 - 9, 0	Standard – The mapping for performance with a balanced response is activated.

The **Map-Select** switch for the basic setting is used to preselect the engine characteristic.

6.7 Map-Select switch for vehicle operation

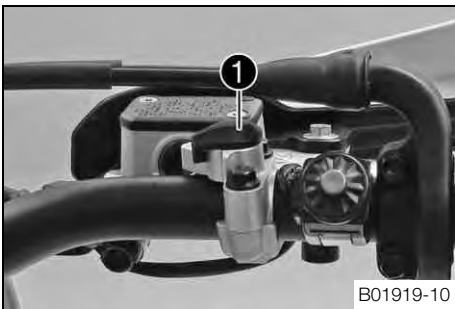

B01919-10

The **Map-Select** switch for vehicle operation ❶ is fitted on the right side of the handlebar.

Possible states

I	Standard – In this position, STANDARD Mapping is always activated.
II	SOFT or ADVANCED – In this position, the mapping that is set on the Map-Select switch for the basic setting is activated.

The engine characteristic can be changed on the handlebar using the **Map-Select** switch for vehicle operation. This change is activated while the engine is idling or on restarting.

6.8 Overview of indicator lamps



B01831-10

Possible states

	FI warning lamp (MIL) lights up/flashes orange – The OBD (onboard diagnosis) has identified an emissions- or safety-critical fault.
--	---

6.9 Opening the filler cap



Danger

Fire hazard Fuel is highly flammable.

- Never refuel the vehicle near open flames or burning cigarettes, and always switch off the engine first. Be careful that no fuel is spilt, especially on hot vehicle components. Clean up spilt fuel immediately.
- The fuel in the fuel tank expands when warm and may emerge if overfilled. Follow the instructions on refueling.



Warning

Danger of poisoning Fuel is poisonous and a health hazard.

- Fuel must not come into contact with the skin, eyes, or clothing. Do not breathe in the fuel vapors. If contact occurs with the eyes, rinse with water immediately and contact a physician. Immediately clean contaminated areas on the skin with soap and water. If fuel is swallowed, contact a physician immediately. Change clothing that is contaminated with fuel. Store fuel properly in a suitable canister and keep away from children.



Warning

Environmental hazard Improper handling of fuel is a danger to the environment.

- Do not allow fuel to get into the ground water, the ground, or the sewage system.

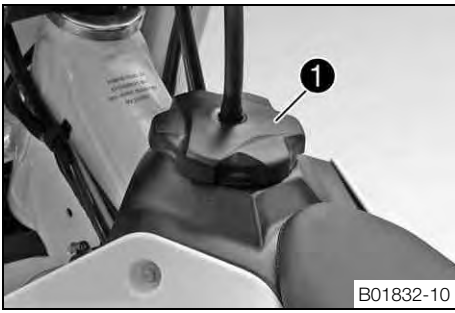

- Turn filler cap ① counterclockwise and lift it off.

6.10 Closing the filler cap

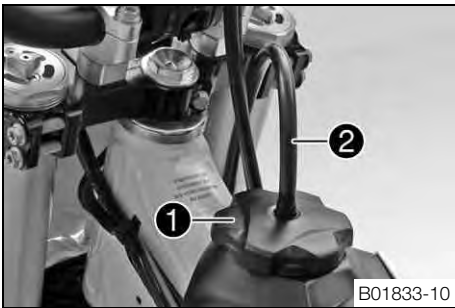

- Mount filler cap ① and turn it clockwise until the fuel tank is tightly closed.

i Info

Run the fuel tank breather hose ② without kinks.

6.11 Cold start button



The cold start button ① is fitted on the left on the throttle valve body. The injection system extends the injection time if the engine is cold and the outside temperature is low. To help the engine burn the increased amount of fuel, it must be supplied with additional oxygen by pulling the cold start button.

Possible states

- The cold start button is activated – The cold start button is pulled out all the way.
- The cold start button is deactivated – The cold start button is pushed in all the way.

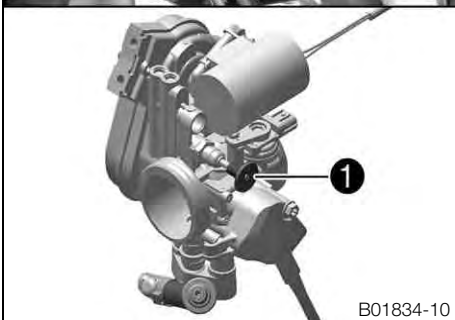

6.12 Idle speed adjusting screw



The idle setting of the throttle valve body has a big influence on the vehicle's starting behavior, on stable idling, and on vehicle response when the throttle is opened. This means that an engine with a correctly set idle speed is easier to start than if the idle is set wrongly.

The idle speed is adjusted with the idle speed adjusting screw **1**.
 Increase the idle speed by turning the idle speed adjusting screw clockwise.
 Decrease the idle speed by turning the idle speed adjusting screw counterclockwise.

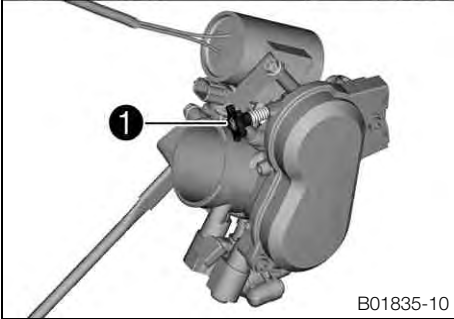

6.13 Shift lever

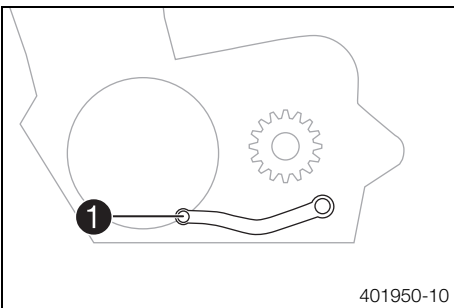

Shift lever **1** is mounted on the left side of the engine.

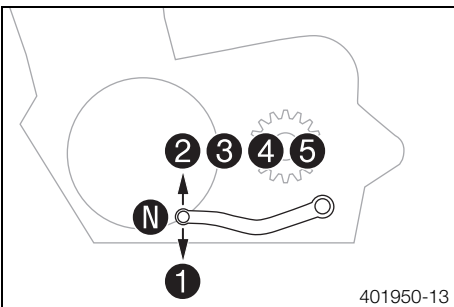

The gear positions can be seen in the photograph.
 The neutral or idle position is between the first and second gears.

6.14 Foot brake lever

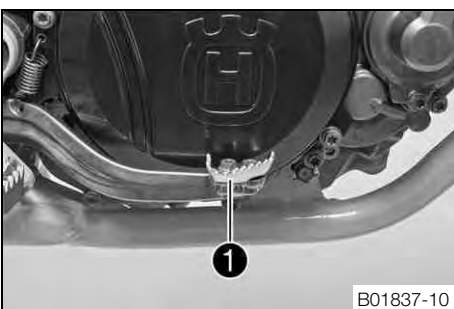

Foot brake lever **1** is located in front of the right footrest.
 The foot brake lever is used to activate the rear brake.

6.15 Plug-in stand

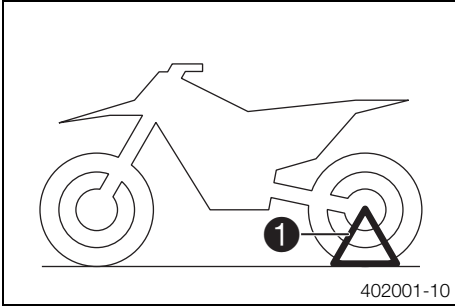

The holder for the plug-in stand ❶ is the left side of the wheel spindle.
The plug-in stand is used to park the motorcycle.



Info

Remove the plug-in stand before starting on a trip.

7.1 Advice on first use



Danger

Danger of accidents Danger arising from the rider's judgement being impaired.

- Do not operate the vehicle while under the influence of alcohol, drugs and certain medications or physically or mentally impaired.



Warning

Risk of injury Missing or poor protective clothing presents an increased safety risk.

- Wear protective clothing (helmet, boots, gloves, pants and jacket with protectors) every time you ride the vehicle. Always wear protective clothing that is in good condition and meets the legal requirements.



Warning

Danger of crashing Poor vehicle handling due to different tire tread patterns on front and rear wheels.

- The front and rear wheels must be fitted with tires with similar tread patterns to prevent loss of control over the vehicle.



Warning

Danger of accidents Critical riding behavior due to inappropriate riding.

- Adapt your riding speed to the road conditions and your riding ability.



Warning

Danger of accidents Accident risk caused by presence of a passenger.

- Your vehicle is not designed to carry passengers. Do not ride with a passenger.



Warning

Danger of accidents Failure of brake system.

- If the foot brake lever is not released, the brake linings drag continuously. The rear brake may fail due to overheating. Take your foot off the foot brake lever when you are not braking.



Warning

Danger of accidents Unstable riding behavior.

- Do not exceed the maximum permissible weight and axle loads.



Warning

Risk of misappropriation Usage by unauthorized persons.

- Never leave the vehicle while the engine is running. Secure the vehicle against use by unauthorized persons.



Info

When using your motorcycle, remember that others may feel disturbed by excessive noise.

- Make sure that the pre-delivery inspection work has been carried out by an authorized Husqvarna workshop.
 - ✓ You receive a delivery certificate and the service record at vehicle handover.
- Before your first trip, read the entire operating instructions carefully.
- Familiarize yourself with the controls.
- Adjust the basic position of the clutch lever. (☞ p. 53)
- Adjust the basic position of the hand brake lever. (☞ p. 55)
- Adjust the basic position of the foot brake lever. (☞ p. 59)
- Adjust the basic position of the shift lever. (☞ p. 75)
- Get used to handling the motorcycle on a suitable piece of land before making a longer trip.



Info

Your motorcycle is not authorized for riding on public roads.

Offroad, you should be accompanied by another person on another machine so that you can help each other.

- Try also to ride as slowly as possible and in a standing position to get a better feeling for the vehicle.
- Do not make any offroad trips that over-stress your ability and experience.
- Hold the handlebar firmly with both hands and keep your feet on the footrests when riding.
- Do not take luggage along.

- Do not exceed the overall maximum permitted weight and the axle loads.

Guideline

Maximum permissible overall weight	335 kg (739 lb.)
Maximum permissible front axle load	145 kg (320 lb.)
Maximum permissible rear axle load	190 kg (419 lb.)

- Run in the engine. (☛ p. 17)

7.2 Running in the engine

- During the running-in phase, do not exceed the specified engine speed and engine performance.

Guideline

Maximum engine speed	
During the first operating hour	7,000 rpm
Maximum engine performance	
During the first 3 operating hours	≤ 75 %

- Avoid fully opening the throttle!

7.3 Preparing the vehicle for difficult operating conditions

i Info

Use of the vehicle under difficult conditions, such as on sand or on wet and muddy surfaces, can lead to considerably more rapid wear of components such as the drive train, brake system, or suspension components. For this reason, it may be necessary to inspect or replace parts before the next scheduled service.

- Husqvarna recommends using the specified engine oil when operating the vehicle under harsh conditions and to increase motorcycle performance.

Engine oil (SAE 10W/60) (☛ p. 91)

- Seal the air filter box. ☛ (☛ p. 44)
- Clean the air filter and air filter box. ☛ (☛ p. 43)

i Info

Check the air filter approx. every 30 minutes.

- Additionally secure the rubber grip. (☛ p. 53)
- Check the electrical connector for humidity and corrosion and to ensure it is firmly seated.
 - » If humidity, corrosion or damage is found:
 - Clean and dry the connector, or change it if necessary.

Difficult operating conditions are:

- Rides on dry sand. (☛ p. 17)
- Rides on wet sand. (☛ p. 18)
- Rides on wet and muddy surfaces. (☛ p. 18)
- Rides at high temperatures and low speeds. (☛ p. 19)
- Rides at low temperatures or in snow. (☛ p. 19)

7.4 Preparing for rides on dry sand



- Fit a dust protection device on the air filter.

Dust protection device for air filter (77206920100)

i Info

Observe the **Husky Power** fitting instructions.



- Fit a sand protection device on the air filter.

Sand protection device for air filter (59006922000)



Info

Observe the **Husky Power** fitting instructions.



- Clean the chain.
- Fit the steel sprocket.



Tip

Do not grease the chain.

- Clean the radiator fins.
- Straighten bent radiator fins carefully.
- If used in sand regularly, replace the piston every 20 operating hours.

7.5 Preparing for rides on wet sand



- Fit a waterproofing device on the air filter.

Waterproofing device for air filter (77206921100)



Info

Observe the **Husky Power** fitting instructions.



- Clean the chain.
- Fit the steel sprocket.



Tip

Do not grease the chain.

- Clean the radiator fins.
- Straighten bent radiator fins carefully.
- If used in sand regularly, replace the piston every 20 operating hours.

7.6 Preparing for rides on wet and muddy surfaces



- Fit a waterproofing device on the air filter.

Waterproofing device for air filter (77206921100)



Info

Observe the **Husky Power** fitting instructions.



- Fit the steel sprocket.
- Clean the motorcycle. (🔧 p. 80)
- Straighten bent radiator fins carefully.

7.7 Preparing for rides at high temperatures and low speeds



- Adjust the secondary drive to the road conditions.

i **Info**

The engine oil quickly gets hot if the clutch has to be operated very often due to an excessively high secondary drive.

- Clean the chain.
- Clean the radiator fins.
- Straighten bent radiator fins carefully.
- Check the coolant level. (🔧 p. 72)

7.8 Preparing for rides at low temperatures or in snow



- Fit a waterproofing device on the air filter.

Waterproofing device for air filter (77206921100)

i **Info**

Observe the **Husky Power** fitting instructions.

8.1 Checks and maintenance before putting into operation



Info

Before every trip, check the condition of the vehicle and ensure that it is safe to operate. The vehicle must be in perfect technical condition when used.

- Check the engine oil level. (☛ p. 76)
- Check the front brake fluid level. (☛ p. 56)
- Check the rear brake fluid level. (☛ p. 60)
- Check the front brake linings. (☛ p. 57)
- Check the rear brake linings. (☛ p. 61)
- Check that the brake system is functioning properly.
- Check the coolant level. (☛ p. 72)
- Check for chain dirt accumulation. (☛ p. 48)
- Check the chain, rear sprocket, engine sprocket and chain guide. (☛ p. 50)
- Check the chain tension. (☛ p. 49)
- Check the tire condition. (☛ p. 66)
- Check the tire air pressure. (☛ p. 67)
- Check the spoke tension. (☛ p. 67)
- Clean the dust boots of the fork legs. (☛ p. 33)
- Bleed the fork legs. (☛ p. 32)
- Check the air filter.
- Check the settings of all controls and ensure that they can be operated smoothly.
- Check all screws, nuts and hose clamps regularly for tightness.
- Check the fuel reserves.

8.2 Starting



Danger

Danger of poisoning Exhaust gases are toxic and inhaling them may result in unconsciousness and/or death.

- When running the engine, always make sure there is sufficient ventilation, and do not start or run the engine in an enclosed space without an effective exhaust extraction system.

Note

Engine failure High engine speeds in cold engines have a negative effect on the service life of the engine.

- Always warm up the engine at low engine speeds.

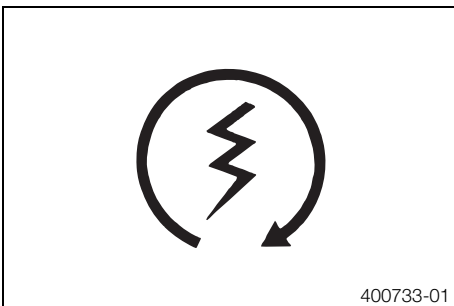

- Remove the plug-in stand.
- Shift gear to neutral.

Condition

Ambient temperature: < 20 °C (< 68 °F)

- Pull the cold start button out all the way.
- Press the electric starter button.



Info

Press the electric starter button for at most 5 seconds. Wait for a least 5 seconds before trying again.

FI warning lamp lights up briefly as a functional control when starting.

8.3 Starting off

- Pull the clutch lever, engage 1st gear, release the clutch lever slowly and simultaneously open the throttle carefully.

8.4 Shifting, riding

Warning

Danger of accidents If you change down at high engine speed, the rear wheel can lock up.

- Do not change into a low gear at high engine speed. The engine races and the rear wheel can lock up.

Info

If you hear unusual noises while riding, stop immediately, switch off the engine and contact an authorized Husqvarna workshop. First gear is used for starting off or for steep inclines.

- When conditions allow (incline, road situation, etc.), you can shift into a higher gear. To do so, release the throttle while simultaneously pulling the clutch lever, shift into the next gear, release the clutch lever and open the throttle.
- If the cold start button was pulled out during starting, push the cold start button all the way in after the engine warms up.
- After reaching maximum speed by fully opening the throttle grip, turn the throttle back so it is $\frac{3}{4}$ open. This will barely reduce the speed but fuel consumption will be considerably lower.
- Always open the throttle only as much as the engine can handle – opening the throttle abruptly increases fuel consumption.
- To shift down, brake and close the throttle at the same time.
- Pull the clutch lever and shift into a lower gear, release the clutch lever slowly and open the throttle or shift again.
- Switch off the engine if you expect to be standing for a long time.

Guideline

≥ 1 min

- Avoid frequent and longer slipping of the clutch. This heats the engine oil, the engine and the cooling system.
- Ride with a lower engine speed instead of with a high engine speed and a slipping clutch.

8.5 Applying the brakes

Warning

Danger of accidents If you brake too hard, the wheels can lock.

- Adapt your braking to the traffic situation and the road conditions.

Warning

Danger of accidents Reduced braking efficiency caused by spongy pressure point of front or rear brake.

- Check the brake system and do not continue riding. (Your authorized Husqvarna workshop will be glad to help.)

Warning

Danger of accidents Reduced braking efficiency due to a wet or dirty brake system.

- Clean or dry a dirty or wet brake system by riding and braking gently.

- On sandy, wet or slippery surfaces, use the rear brake.
- Braking should always be completed before you go into a bend. Change down to a lower gear appropriate to your road speed.
- On long downhill stretches, use the braking effect of the engine. Change down one or two gears, but do not overstress the engine. In this way, you have to apply the brakes far less frequently and the brake system does not overheat.

8.6 Stopping, parking

Warning

Risk of misappropriation Usage by unauthorized persons.

- Never leave the vehicle while the engine is running. Secure the vehicle against use by unauthorized persons.

Warning

Danger of burns Some vehicle components become very hot when the vehicle is operated.

- Do not touch hot components such as exhaust system, radiator, engine, shock absorber, and the brake system. Allow these components to cool down before starting work on them.

Note

Danger of damage The parked vehicle may roll away or fall over.

- Always place the vehicle on a firm and even surface.

Note

Fire hazard Some vehicle components become very hot when the vehicle is operated.

- Do not park the vehicle near flammable or explosive substances. Do not place objects on the vehicle while it is still warm from being run. Always let the vehicle cool first.

-
- Brake the motorcycle.
 - Shift gear to neutral.
 - Press and hold the kill switch  while the engine is idling until the engine stops.
 - Park the motorcycle on firm ground.

8.7 Transport

Note

Danger of damage The parked vehicle may roll away or fall over.

- Always place the vehicle on a firm and even surface.

Note

Fire hazard Some vehicle components become very hot when the vehicle is operated.

- Do not park the vehicle near flammable or explosive substances. Do not place objects on the vehicle while it is still warm from being run. Always let the vehicle cool first.

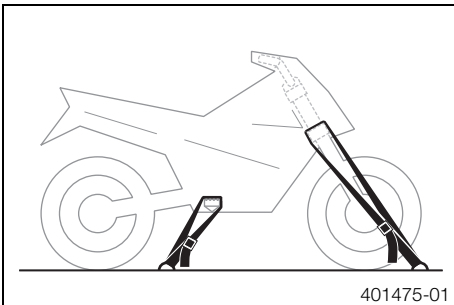

- Switch off the engine.
- Use tension belts or other suitable devices to secure the motorcycle against accidents or falling over.

8.8 Refueling



Danger

Fire hazard Fuel is highly flammable.

- Never refuel the vehicle near open flames or burning cigarettes, and always switch off the engine first. Be careful that no fuel is spilt, especially on hot vehicle components. Clean up spilt fuel immediately.
- The fuel in the fuel tank expands when warm and may emerge if overfilled. Follow the instructions on refueling.



Warning

Danger of poisoning Fuel is poisonous and a health hazard.

- Fuel must not come into contact with the skin, eyes, or clothing. Do not breathe in the fuel vapors. If contact occurs with the eyes, rinse with water immediately and contact a physician. Immediately clean contaminated areas on the skin with soap and water. If fuel is swallowed, contact a physician immediately. Change clothing that is contaminated with fuel.

Note

Material damage Premature clogging of the fuel filter.

- In some countries and regions, the available fuel quality and cleanliness may not be sufficient. This will result in problems with the fuel system. (Your authorized Husqvarna workshop will be glad to help.)
- Only refuel with clean fuel that meets the specified standards.



Warning

Environmental hazard Improper handling of fuel is a danger to the environment.

- Do not allow fuel to get into the ground water, the ground, or the sewage system.

- Switch off the engine.
- Open the filler cap. (☛ p. 12)
- Fill the fuel tank with fuel up to measurement **A**.

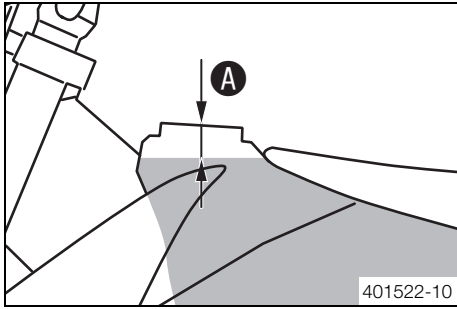

Guideline

Measurement of A	35 mm (1.38 in)	
Total fuel tank capacity, approx.	7.5 l (1.98 US gal)	Super unleaded (ROZ 95/RON 95/PON 91) (☛ p. 92)

- Close the filler cap. (☛ p. 13)

9.1 Service schedule

	Every 40 operating hours - corresponds to about 280 liters of fuel (74 US gal)	Every 30 operating hours - corresponds to about 210 liters of fuel (55.5 US gal)	Once after 20 operating hours / Every 20 operating hours - corresponds to about 140 liters of fuel (37 US gal)	Every 10 operating hours - corresponds to about 70 liters of fuel (18.5 US gal) / after every race	Once after 1 operating hour - corresponds to about 7 liters of fuel (1.8 US gal)
Read out the fault memory using the Husqvarna diagnostics tool.	○	●	●	●	●
Check and charge the battery.		●	●	●	●
Check the front brake linings. (🔧 p. 57)		●	●	●	●
Check the rear brake linings. (🔧 p. 61)		●	●	●	●
Check the brake discs. (🔧 p. 55)		●	●	●	●
Check the brake lines for damage and leakage.		●	●	●	●
Check the rear brake fluid level. (🔧 p. 60)		●	●	●	●
Check the free travel of the foot brake lever. (🔧 p. 59)		●	●	●	●
Check the frame and swingarm.		●	●	●	●
Check the swingarm bearing.			●		●
Check the shock absorber linkage.		●	●	●	●
Conduct a minor fork service.		●	●	●	●
Conduct a major fork service.				●	
Service the shock absorber.			○		●
Check the tire condition. (🔧 p. 66)	○	●	●	●	●
Check the tire air pressure. (🔧 p. 67)	○	●	●	●	●
Check the wheel bearing for play.		●	●	●	●
Check the wheel hubs.		●	●	●	●
Check the rim run-out.	○	●	●	●	●
Check the spoke tension. (🔧 p. 67)	○	●	●	●	●
Check the chain, rear sprocket, engine sprocket and chain guide. (🔧 p. 50)		●	●	●	●
Check the chain tension. (🔧 p. 49)	○	●	●	●	●
Grease all moving parts (e.g., hand lever, chain, ...) and check for smooth operation.		●	●	●	●
Check/rectify the fluid level of the hydraulic clutch. (🔧 p. 53)		●	●	●	●
Check the front brake fluid level. (🔧 p. 56)		●	●	●	●
Check the free travel of the hand brake lever. (🔧 p. 55)		●	●	●	●
Check the steering head bearing play. (🔧 p. 37)	○	●	●	●	●
Check the valve clearance.	○			●	
Check the clutch.			●		●
Change the shaft seal rings of the water pump.				●	
Change the engine oil and oil filter, clean the oil screen. (🔧 p. 77)	○	●	●	●	●
Check all hoses (e. g. fuel, cooling, bleeding, drainage) and sleeves for tearing, leaks and incorrect routing.	○	●	●	●	●
Check the antifreeze and coolant level. (🔧 p. 71)	○	●	●	●	●
Check the cables for damage and routing without sharp bends.		●	●	●	●
Check that the throttle cables are undamaged, routed without sharp bends and set correctly.	○	●	●	●	●
Clean the air filter and air filter box. (🔧 p. 43)		●	●	●	●
Change the glass fiber yarn filling of the main silencer. (🔧 p. 45)			●		●
Check the screws and nuts for tightness.	○	●	●	●	●
Change the fuel screen. (🔧 p. 76)	○	●	●	●	●
Check the fuel pressure.		●	●	●	●
Check the idle.	○	●	●	●	●
Final check: Check the vehicle for roadworthiness and take a test ride.	○	●	●	●	●
Read out the fault memory using after the test ride the Husqvarna diagnostics tool.	○	●	●	●	●
Make the service entry in Husqvarna Dealer.net and in the service booklet.	○	●	●	●	●

- One-time interval
- Periodic interval

9.2 Service work (as additional order)

	Annually	
Every 100 operating hours - corresponds to about 700 liters of fuel (185 US gal)		
Every 50 operating hours - corresponds to about 350 liters of fuel (92.5 US gal)		
Change the front brake fluid. 🛠️		●
Change the rear brake fluid. 🛠️		●
Change the hydraulic clutch fluid. 🛠️ (🔧 p. 53)		●
Grease the steering head bearing. 🛠️ (🔧 p. 38)		●
Change the spark plug and spark plug connector. 🛠️		●
Change the piston. 🛠️	●	●
Check/measure the cylinder. 🛠️	●	●
Check the cylinder head. 🛠️	●	●
Change the valves, valve springs and valve spring seats. 🛠️		●
Check the camshaft and cam lever. 🛠️	●	●
Change the connecting rod, conrod bearing, and crank pin. 🛠️		●
Check the transmission and shift mechanism. 🛠️		●
Check the oil pressure regulator valve. 🛠️	●	●
Change the suction pump. 🛠️		●
Check the force pump and lubrication system. 🛠️		●
Change the timing chain. 🛠️		●
Check the timing assembly. 🛠️	●	●
Change all engine bearings. 🛠️		●

- Periodic interval

10.1 Checking the basic chassis setting with the rider's weight

i Info

When adjusting the basic chassis setting, first adjust the shock absorber and then the fork.

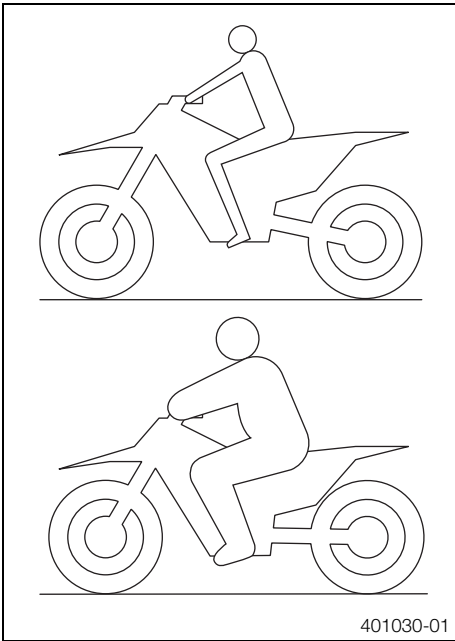

401030-01

- For optimal motorcycle riding characteristics and to avoid damage to forks, shock absorbers, swingarm and frame, the basic settings of the suspension components must match the rider's weight.
- As delivered, Husqvarna motorcycles are adjusted for an average rider's weight (with full protective clothing).

Guideline

Standard rider weight	75... 85 kg (165... 187 lb.)
-----------------------	------------------------------

- If the rider's weight is above or below this range, the basic setting of the suspension components must be adjusted accordingly.
- Small weight differences can be compensated by adjusting the spring preload, but in the case of large weight differences, the springs must be replaced.

10.2 Compression damping of the shock absorber

The compression damping of the shock absorber is divided into two ranges: high-speed and low-speed.

High-speed and low-speed refer to the compression speed of the rear wheel suspension and not to the vehicle speed.

The high-speed setting, for example, has an effect on the landing after a jump: the rear wheel suspension compresses more quickly.

The low-speed setting, for example, has an effect when riding over long ground swells: the rear wheel suspension compresses more slowly.

These two ranges can be adjusted separately, although the transition between high-speed and low-speed is gradual. Thus, changes in the high-speed range affect the compression damping in the low-speed range and vice versa.

10.3 Adjusting the low-speed compression damping of the shock absorber

⚠ Caution

Danger of accidents Disassembly of pressurized parts can lead to injury.

- The shock absorber is filled with high density nitrogen. Adhere to the description provided. (Your authorized Husqvarna workshop will be glad to help.)

i Info

The low-speed setting can be seen during the slow to normal compression of the shock absorber.

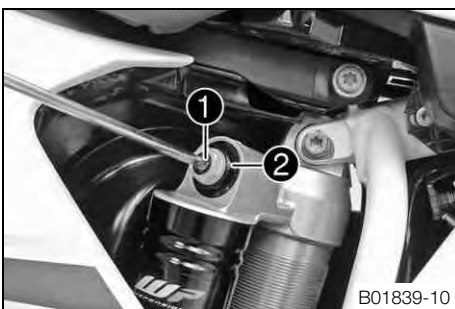

B01839-10

- Turn adjusting screw **1** clockwise with a screwdriver up to the last perceptible click.

i Info

Do not loosen fitting **2**.

- Turn counterclockwise by the number of clicks corresponding to the shock absorber type.

Guideline

Compression damping, low-speed	
Comfort	17 clicks
Standard	15 clicks
Sport	13 clicks

i Info
Turn clockwise to increase damping; turn counterclockwise to reduce damping.

10.4 Adjusting the high-speed compression damping of the shock absorber

! Caution
Danger of accidents Disassembly of pressurized parts can lead to injury.

- The shock absorber is filled with high density nitrogen. Adhere to the description provided. (Your authorized Husqvarna workshop will be glad to help.)

i Info
The high-speed setting can be seen during the fast compression of the shock absorber.

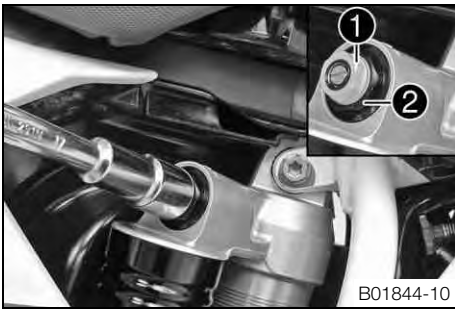

- Turn adjusting screw **1** all the way clockwise with a socket wrench.

i Info
Do not loosen fitting **2**.

- Turn counterclockwise by the number of turns corresponding to the shock absorber type.

Guideline

Compression damping, high-speed	
Comfort	2.5 turns
Standard	2 turns
Sport	1.5 turns

i Info
Turn clockwise to increase damping; turn counterclockwise to reduce damping.

10.5 Adjusting the rebound damping of the shock absorber

! Caution
Danger of accidents Disassembly of pressurized parts can lead to injury.

- The shock absorber is filled with high density nitrogen. Adhere to the description provided. (Your authorized Husqvarna workshop will be glad to help.)

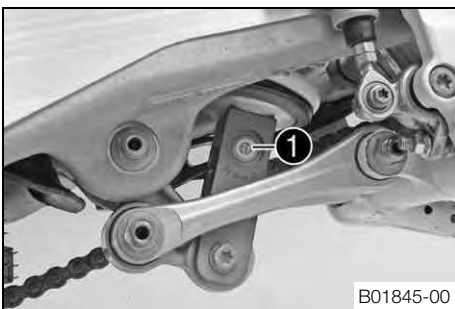

- Turn adjusting screw **1** clockwise up to the last perceptible click.
- Turn counterclockwise by the number of clicks corresponding to the shock absorber type.

Guideline

Rebound damping	
Comfort	17 clicks
Standard	15 clicks
Sport	13 clicks

i Info
Turn clockwise to increase damping; turn counterclockwise to reduce damping.

10.6 Measuring rear wheel sag unloaded

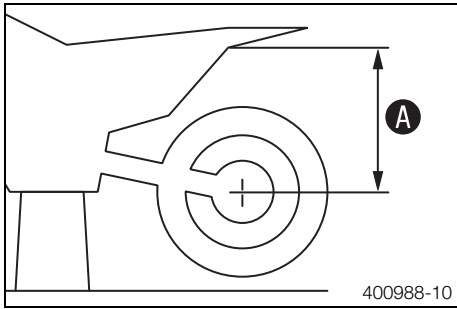

Preparatory work

- Raise the motorcycle with the lift stand. (🔧 p. 32)

Main work

- Measure the distance – as vertical as possible – between the rear axle and a fixed point, for example, a mark on the side cover.
- Note down the value as dimension **A**.

Finishing work

- Remove the motorcycle from the lift stand. (🔧 p. 32)

10.7 Checking the static sag of the shock absorber

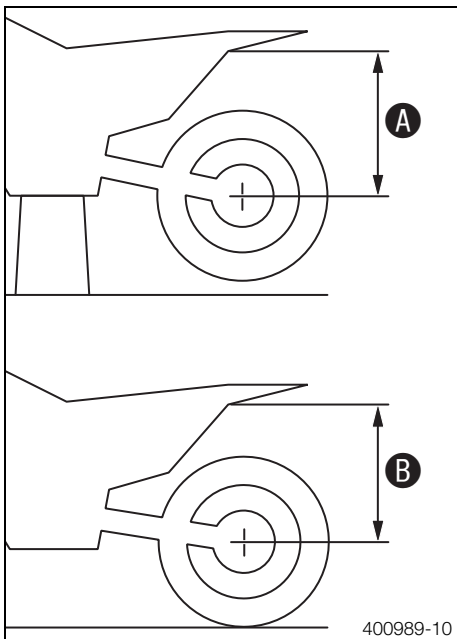

- Measure distance **A** of rear wheel unloaded. (🔧 p. 28)
- Hold the motorcycle upright with the aid of an assistant.
- Measure the distance between the rear axle and the fixed point again.
- Note down the value as dimension **B**.

i Info

The static sag is the difference between measurements **A** and **B**.

- Check the static sag.

Static sag	30 mm (1.18 in)
------------	-----------------

- » If the static sag is less or more than the specified value:
 - Adjust the spring preload of the shock absorber. 🛠️ (🔧 p. 29)

10.8 Checking the riding sag of the shock absorber

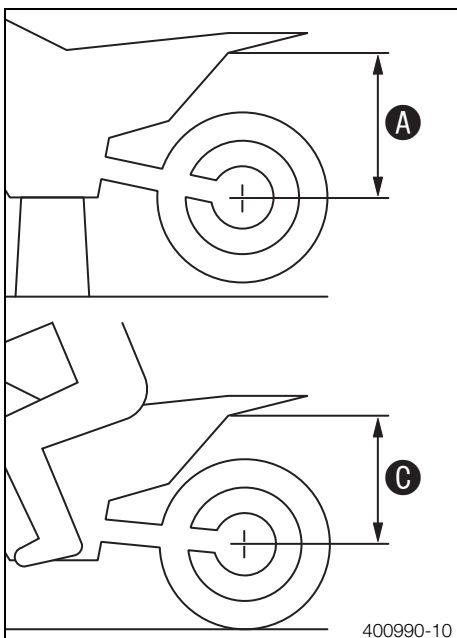

- Measure distance **A** of rear wheel unloaded. (🔧 p. 28)
- With another person holding the motorcycle, the rider, wearing full protective clothing, sits on the seat in a normal sitting position (feet on footrests) and bounces up and down a few times.
 - ✓ The rear wheel suspension levels out.
- Another person now measures the distance between the rear axle and the fixed point.
- Note down the value as dimension **C**.

i Info

The riding sag is the difference between measurements **A** and **C**.

- Check the riding sag.

Riding sag	100 mm (3.94 in)
------------	------------------

- » If the riding sag differs from the specified measurement:
 - Adjust the riding sag. 🛠️ (🔧 p. 29)

10.9 Adjusting the spring preload of the shock absorber

Caution
Danger of accidents Disassembly of pressurized parts can lead to injury.

- The shock absorber is filled with high density nitrogen. Adhere to the description provided. (Your authorized Husqvarna workshop will be glad to help.)

Info
 Before changing the spring preload, make a note of the present setting, e.g., by measuring the length of the spring.

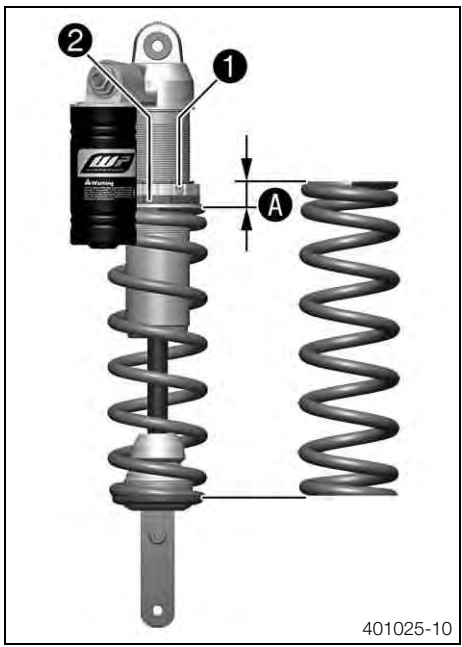

401025-10

Preparatory work

- Raise the motorcycle with the lift stand. (p. 32)
- Remove the shock absorber. (p. 40)
- After removing the shock absorber, clean it thoroughly.

Main work

- Loosen screw 1.
- Turn adjusting ring 2 until the spring is no longer under tension.

Hook wrench (T106S)

- Measure the overall spring length while the spring is not under tension.
- Tighten the spring by turning adjusting ring 2 to measurement A.

Guideline

Spring preload	12 mm (0.47 in)
----------------	-----------------

Info
 Depending on the static sag and/or the riding sag, it may be necessary to increase or decrease the spring preload.

- Tighten screw 1.

Guideline

Screw, shock absorber adjusting ring	M5	5 Nm (3.7 lbf ft)
--------------------------------------	----	-------------------

Finishing work

- Install the shock absorber. (p. 41)
- Remove the motorcycle from the lift stand. (p. 32)

10.10 Adjusting the riding sag

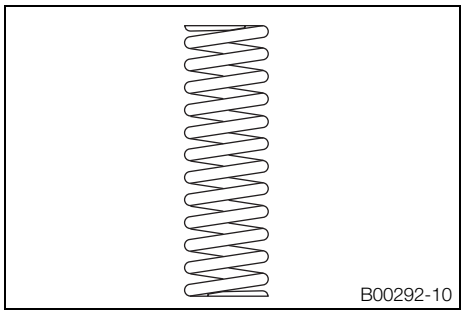

B00292-10

Preparatory work

- Raise the motorcycle with the lift stand. (p. 32)
- Remove the shock absorber. (p. 40)
- After removing the shock absorber, clean it thoroughly.

Main work

- Choose and mount a suitable spring.

Guideline

Spring rate	
Weight of rider: 65... 75 kg (143... 165 lb.)	51 N/mm (291 lb/in)
Weight of rider: 75... 85 kg (165... 187 lb.)	54 N/mm (308 lb/in)
Weight of rider: 85... 95 kg (187... 209 lb.)	57 N/mm (325 lb/in)

Info
 The spring rate is shown on the outside of the spring.

Finishing work

- Install the shock absorber. (p. 41)

- Check the static sag of the shock absorber. (☛ p. 28)
- Check the riding sag of the shock absorber. (☛ p. 28)
- Adjust the rebound damping of the shock absorber. (☛ p. 27)
- Remove the motorcycle from the lift stand. (☛ p. 32)

10.11 Checking the basic setting of the fork

i **Info**

For various reasons, no exact riding sag can be determined for the forks.

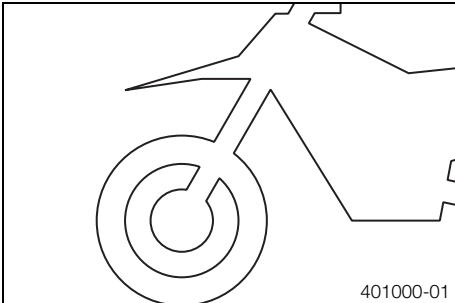

- As with the shock absorber, smaller differences in the rider's weight can be compensated by the spring preload.
- However, if the fork is often overloaded (hard end stop on compression), harder springs must be fit to avoid damage to the fork and frame.

10.12 Adjusting the compression damping of the fork

i **Info**

The hydraulic compression damping determines the fork suspension behavior.



- Turn adjusting screws **1** clockwise all the way.

i **Info**

Adjusting screws **1** are located at the top end of the fork legs. Make the same adjustment on both fork legs.

- Turn counterclockwise by the number of clicks corresponding to the fork type.

Guideline

Compression damping	
Comfort	14 clicks
Standard	12 clicks
Sport	10 clicks

i **Info**

Turn clockwise to increase damping; turn counterclockwise to reduce damping.

10.13 Adjusting the rebound damping of the fork

i **Info**

The hydraulic rebound damping determines the fork suspension behavior.

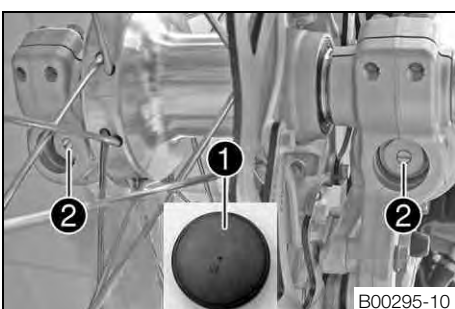

- Remove protection caps **1**.
- Turn adjusting screws **2** clockwise all the way.

i **Info**

Adjusting screws **2** are located at the bottom end of the fork legs. Make the same adjustment on both fork legs.

- Turn counterclockwise by the number of clicks corresponding to the fork type.

Guideline

Rebound damping	
Comfort	14 clicks
Standard	12 clicks
Sport	10 clicks

i Info Turn clockwise to increase damping; turn counterclockwise to reduce damping.

- Mount protection caps **1**.

10.14 Handlebar position

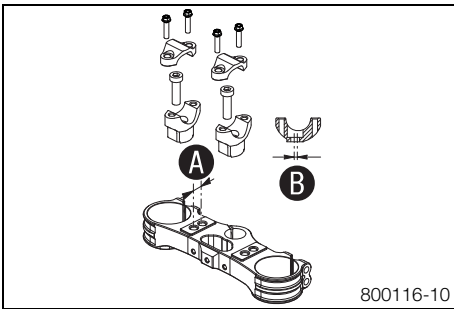

On the upper triple clamp, there are two holes at a distance of **A** to each other.

Hole distance A	15 mm (0.59 in)
-----------------	-----------------

The holes on the handlebar support are placed at a distance of **B** from the center.

Hole distance B	3.5 mm (0.138 in)
-----------------	-------------------

The handlebar can be mounted in four different positions. In this way, the handlebar can be mounted in the position that is most comfortable for the rider.

10.15 Adjusting the handlebar position

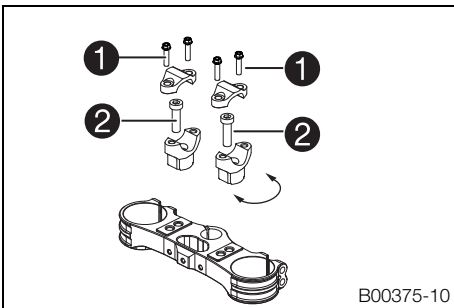

- Remove screws **1**. Take off the handlebar clamps. Take off the handlebar and lay it to one side.

i Info Protect the components against damage by covering them. Do not bend the cables and lines.

- Remove screws **2**. Remove the handlebar support.
- Place the handlebar support in the required position. Mount and tighten screws **2**.

Guideline

Screw, handlebar support	M10	40 Nm (29.5 lbf ft)	Loctite® 243™
--------------------------	-----	------------------------	----------------------

i Info Position the left and right handlebar supports evenly.

- Position the handlebar.

i Info Make sure the cables and wiring are positioned correctly.

- Position the handlebar clamps. Mount and tighten screws **1** evenly.

Guideline

Screw, handlebar clamp	M8	20 Nm (14.8 lbf ft)
------------------------	----	---------------------

11.1 Raising the motorcycle with the lift stand

Note

Danger of damage The parked vehicle may roll away or fall over.

- Always place the vehicle on a firm and even surface.

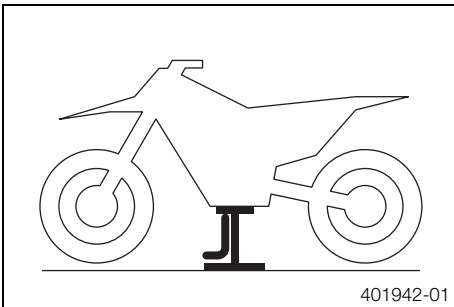

- Raise the motorcycle at the frame underneath the engine.
 - ✓ The wheels must no longer touch the ground.
- Secure the motorcycle against falling over.

Lift stand (81329955000)

11.2 Removing the motorcycle from the lift stand

Note

Danger of damage The parked vehicle may roll away or fall over.

- Always place the vehicle on a firm and even surface.

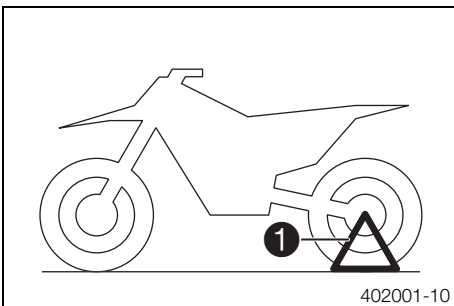

- Remove the motorcycle from the lift stand.
- Remove the lift stand.
- To park the motorcycle, insert plug-in stand ① into the left side of the wheel spindle.

Info

Remove the plug-in stand before starting on a trip.

11.3 Bleeding the fork legs



Preparatory work

- Raise the motorcycle with the lift stand. (☛ p. 32)

Main work

- Release bleeder screws ①.
 - ✓ Any excess pressure escapes from the interior of the fork.
- Mount and tighten bleeder screws.

Finishing work

- Remove the motorcycle from the lift stand. (☛ p. 32)

11.4 Cleaning the dust boots of the fork legs

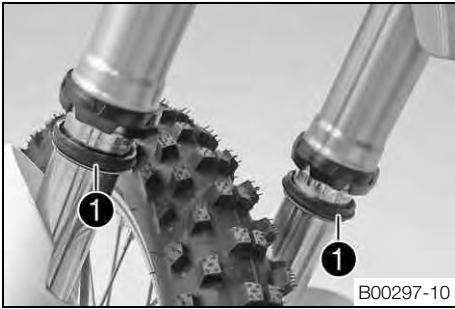

B00297-10

Preparatory work

- Raise the motorcycle with the lift stand. (☞ p. 32)
- Loosen the fork protection. (☞ p. 33)

Main work

- Push dust boots ① of both fork legs downwards.



Info

The dust boots remove dust and coarse dirt particles from the inside fork tubes. Over time, dirt can penetrate behind the dust boots. If this dirt is not removed, the oil seals behind can start to leak.



Warning

Danger of accidents Reduced braking efficiency due to oil or grease on the brake discs.

- Always keep the brake discs free of oil and grease, and clean them with brake cleaner when necessary.

- Clean and oil the dust boots and inner fork tube of both fork legs.
- Press the dust boots back into their normal position.
- Remove excess oil.

Finishing work

- Position the fork protection. (☞ p. 33)
- Remove the motorcycle from the lift stand. (☞ p. 32)

11.5 Loosening the fork protection

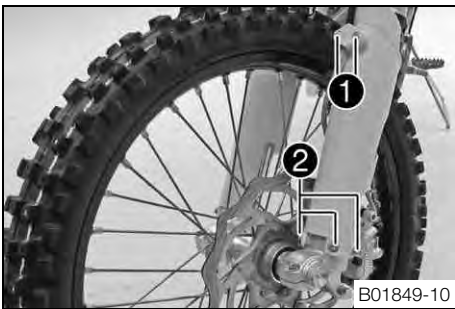

B01849-10

- Remove screws ① and take off the clamp.
- Remove screws ② on the left fork leg. Push the fork protection downwards.
- Remove the screws on the right fork leg. Push the fork protection downwards.

11.6 Positioning the fork protection

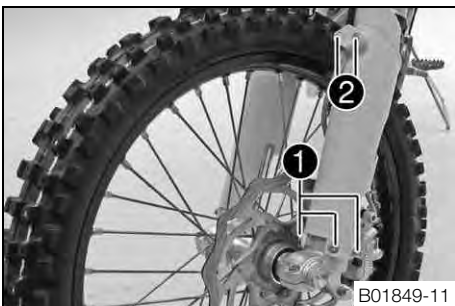

B01849-11

- Position the fork protection on the left fork leg. Mount and tighten screws ①.

Guideline

Remaining screws, chassis	M6	10 Nm (7.4 lbf ft)
---------------------------	----	--------------------

- Position the brake line and clamp. Mount and tighten screws ②.
- Position the fork protection on the right fork leg. Mount and tighten the screws.

Guideline

Remaining screws, chassis	M6	10 Nm (7.4 lbf ft)
---------------------------	----	--------------------

11.7 Removing the fork legs

Preparatory work

- Raise the motorcycle with the lift stand. (☞ p. 32)
- Remove the front wheel. (☞ p. 64)

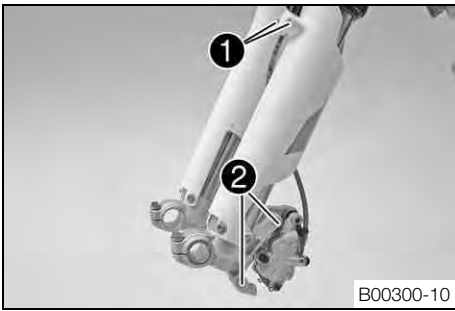

Main work

- Remove screws ① and take off the clamp.
- Remove screws ② and take off the brake caliper.
- Allow the brake caliper and brake line to hang tension-free to the side.



Info

Do not pull the hand brake lever when the front wheel is removed.

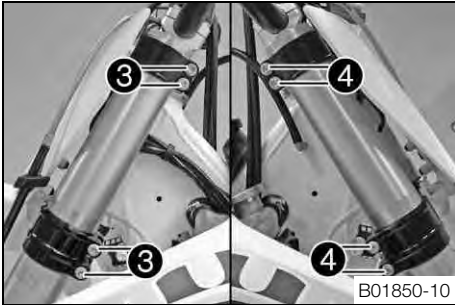

- Loosen screws ③. Take out the left fork leg.
- Unscrew screws ④. Take out the right fork leg.

11.8 Installing the fork legs



Main work

- Position the fork legs.
- ✓ Bleeder screws ① face forward.



Info

Grooves are milled into the side of the upper end of the fork legs. The second milled groove (from the top) must be flush with the top edge of the upper triple clamp.

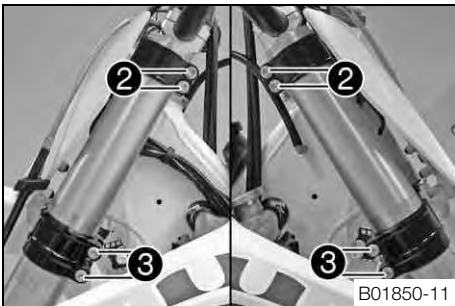

- Tighten screws ②.

Guideline

Screw, top triple clamp	M8	17 Nm (12.5 lbf ft)
-------------------------	----	---------------------

- Tighten screws ③.

Guideline

Screw, bottom triple clamp	M8	12 Nm (8.9 lbf ft)
----------------------------	----	--------------------

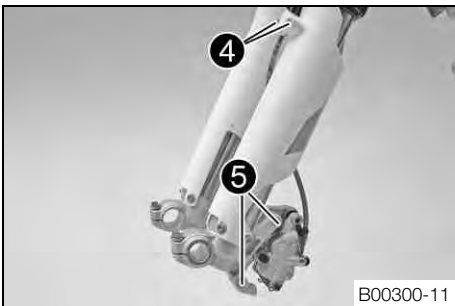

- Position the brake caliper. Mount and tighten screws ⑤.

Guideline

Screw, front brake caliper	M8	25 Nm (18.4 lbf ft)	Loctite® 243™
----------------------------	----	---------------------	----------------------

- Position the brake line and clamp. Mount and tighten screws ④.

Finishing work

- Install the front wheel. 🛠️ (📄 p. 64)

11.9 Removing the fork protector

Preparatory work

- Raise the motorcycle with the lift stand. (p. 32)
- Remove the front wheel. (p. 64)
- Remove the fork legs. (p. 33)

Main work

- Remove screws ① on the left fork leg. Remove the fork protector from above.
- Remove the screws on the right fork leg. Remove the fork protector from above.

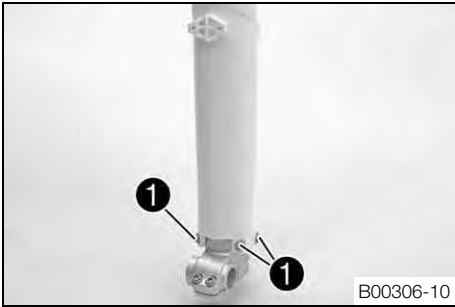

11.10 Installing the fork protector

Main work

- Position the fork protection on the left fork leg. Mount and tighten screws ①.

Guideline

Remaining screws, chassis	M6	10 Nm (7.4 lbf ft)
---------------------------	----	--------------------

- Position the fork protection on the right fork leg. Mount and tighten the screws.

Guideline

Remaining screws, chassis	M6	10 Nm (7.4 lbf ft)
---------------------------	----	--------------------

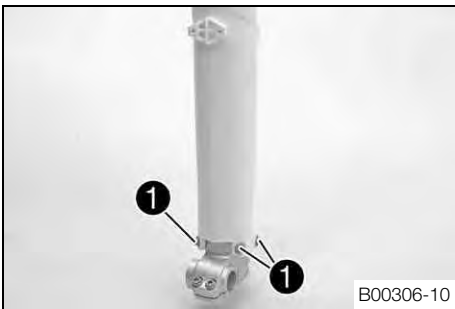

Finishing work

- Install the fork legs. (p. 34)
- Install the front wheel. (p. 64)

11.11 Removing the lower triple clamp

Preparatory work

- Raise the motorcycle with the lift stand. (p. 32)
- Remove the front wheel. (p. 64)
- Remove the fork legs. (p. 33)
- Remove the start number plate. (p. 38)
- Remove the front fender. (p. 39)

Main work

- Take off cable holder ① in front of the left radiator.
- Remove screw ②.
- Remove screw ③.
- Take off the top triple clamp with the handlebar and set it aside.

Info

Protect the components against damage by covering them.
Do not bend the cables and lines.

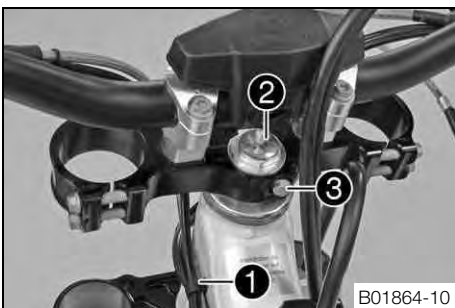

- Remove O-ring ④. Remove protective ring ⑤.
- Take out the lower triple clamp with the steering stem.
- Take out the upper steering head bearing.

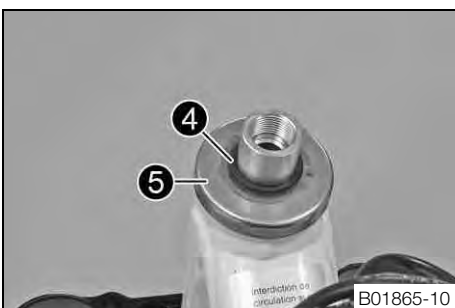

11.12 Installing the lower triple clamp

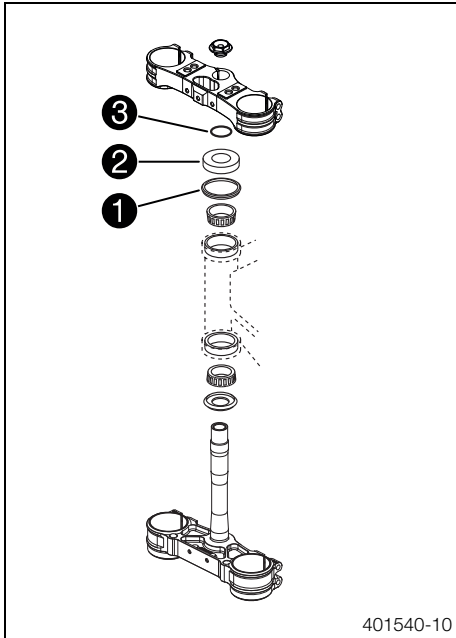

401540-10

Main work

- Clean the bearing and sealing elements, check for damage, and grease.

High viscosity grease (☛ p. 93)

- Insert the lower triple clamp with the steering stem. Mount the upper steering head bearing.
- Check whether the upper steering head seal ① is correctly positioned.
- Slide on protective ring ② and O-ring ③.



B01867-10

- Position the upper triple clamp with the steering.
- Mount screw ④ but do not tighten yet.

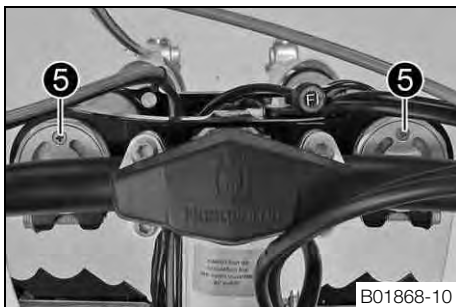

B01868-10

- Position the fork legs.
- ✓ Bleeder screws ⑤ face forward.

Info

Grooves are milled into the side of the upper end of the fork legs. The second milled groove (from the top) must be flush with the top edge of the upper triple clamp.

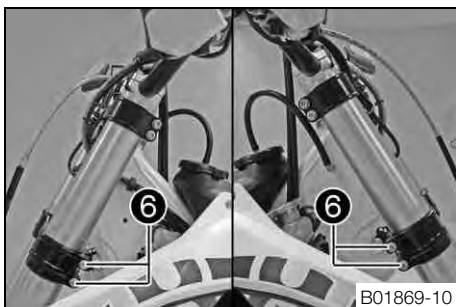

B01869-10

- Fully tighten screws ⑥.

Guideline

Screw, bottom triple clamp	M8	12 Nm (8.9 lbf ft)
----------------------------	----	--------------------



B01870-10

- Tighten screw ④.

Guideline

Screw, top steering head	M20x1.5	12 Nm (8.9 lbf ft)
--------------------------	---------	--------------------



- Mount and tighten screw 7.

Guideline

Screw, top steering stem	M8	17 Nm (12.5 lbf ft)	Loctite® 243™
--------------------------	----	------------------------	---------------

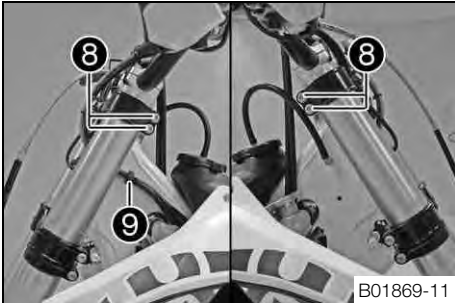

- Using a plastic hammer, tap lightly on the upper triple clamp to avoid strains.
- Tighten screws 8.

Guideline

Screw, top triple clamp	M8	17 Nm (12.5 lbf ft)	
-------------------------	----	---------------------	--

- Secure the wiring harness with cable holder 9.

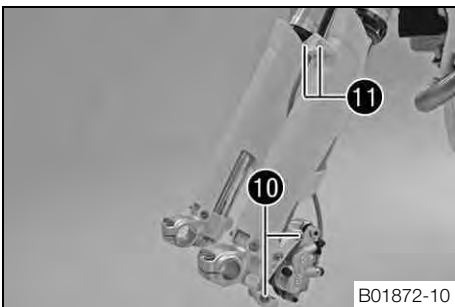

- Position the brake caliper. Mount and tighten screws 10.

Guideline

Screw, front brake caliper	M8	25 Nm (18.4 lbf ft)	Loctite® 243™
----------------------------	----	------------------------	---------------

- Position the brake line and clamp. Mount and tighten screws 11.

Finishing work

- Install the front fender. (☞ p. 39)
- Install the start number plate. (☞ p. 39)
- Install the front wheel. ☞ (☞ p. 64)
- Check that the wiring harness, cables, and brake and clutch lines can move freely and are routed correctly.
- Check the steering head bearing play. (☞ p. 37)
- Remove the motorcycle from the lift stand. (☞ p. 32)

11.13 Checking the steering head bearing play



Warning

Danger of accidents Unstable vehicle handling from incorrect steering head bearing play.

- Adjust the steering head bearing play without delay. (Your authorized Husqvarna workshop will be glad to help.)



Info

If the bike is ridden with play in the steering head bearing, the bearing and the bearing seats in the frame can become damaged over time.

Preparatory work

- Raise the motorcycle with the lift stand. (☞ p. 32)

Main work

- Move the handlebar to the straight-ahead position. Move the fork legs to and fro in the direction of travel.

No play should be noticeable in the steering head bearing.
--

- » If there is noticeable play present:
 - Adjust the play of the steering head bearing. ☞ (☞ p. 38)

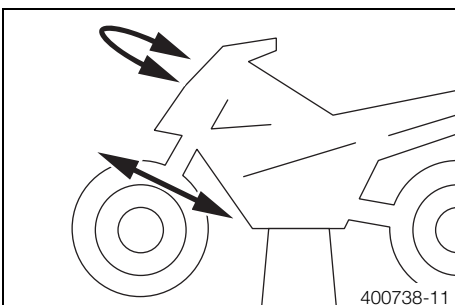

- Move the handlebar to and fro over the entire steering range.

The handlebar must be able to move easily over the entire steering range. No resting locations should be noticeable.

- » If click positions are noticeable:
 - Adjust the play of the steering head bearing. (🔧 p. 38)
 - Check the steering head bearing and change if necessary.

Finishing work

- Remove the motorcycle from the lift stand. (🔧 p. 32)

11.14 Adjusting the play of the steering head bearing 🛠️

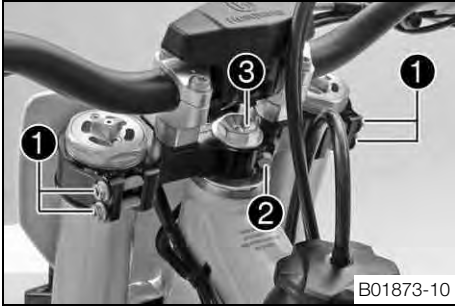

B01873-10

Preparatory work

- Raise the motorcycle with the lift stand. (🔧 p. 32)

Main work

- Loosen screws ❶. Remove screw ❷.
- Loosen and retighten screw ❸.

Guideline

Screw, top steering head	M20x1.5	12 Nm (8.9 lbf ft)
--------------------------	---------	--------------------

- Using a plastic hammer, tap lightly on the upper triple clamp to avoid strains.
- Fully tighten screws ❶.

Guideline

Screw, top triple clamp	M8	17 Nm (12.5 lbf ft)
-------------------------	----	---------------------

- Mount and tighten screw ❷.

Guideline

Screw, top steering stem	M8	17 Nm (12.5 lbf ft)	Loctite® 243™
--------------------------	----	---------------------	----------------------

Finishing work

- Check the steering head bearing play. (🔧 p. 37)
- Remove the motorcycle from the lift stand. (🔧 p. 32)

11.15 Greasing the steering head bearing 🛠️

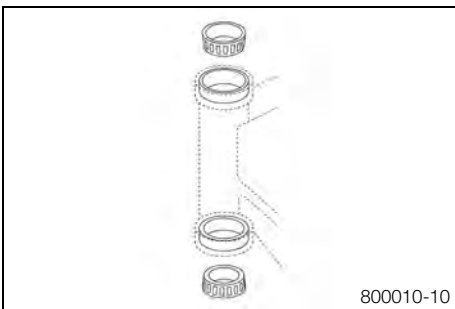

800010-10

- Remove the lower triple clamp. (🔧 p. 35)
- Install the lower triple clamp. (🔧 p. 36)

11.16 Removing the start number plate

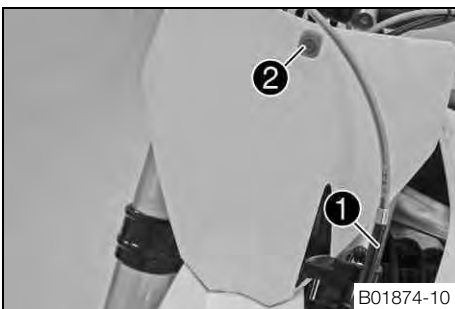

B01874-10

- Take brake line ❶ out of the brake line guide.
- Remove screw ❷. Take off the start number plate.

11.17 Installing the start number plate

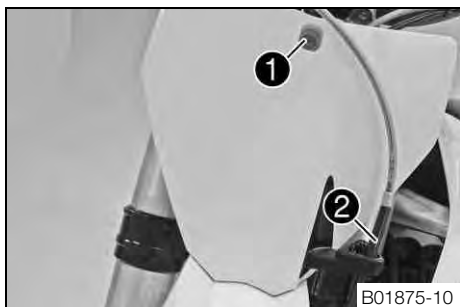

- Position the start number plate. Mount and tighten screw ❶.

Guideline

Remaining screws, chassis	M6	10 Nm (7.4 lbf ft)
---------------------------	----	--------------------

- ✓ The holding lugs engage.
- Position brake line ❷ in the brake line guide.

11.18 Removing the front fender

Preparatory work

- Remove the start number plate. (☛ p. 38)

Main work

- Remove screws ❶ and ❷. Remove the front fender.

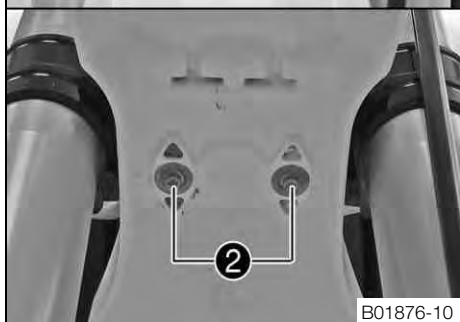
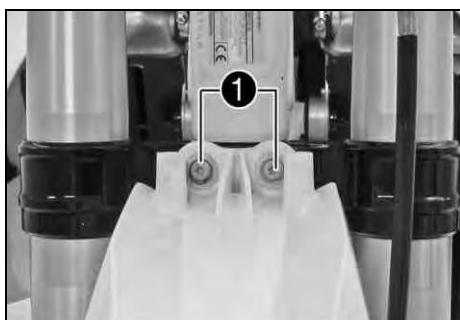

11.19 Installing the front fender

Main work

- Position the front fender. Mount and tighten screws ❶ and ❷.

Guideline

Remaining screws, chassis	M6	10 Nm (7.4 lbf ft)
---------------------------	----	--------------------

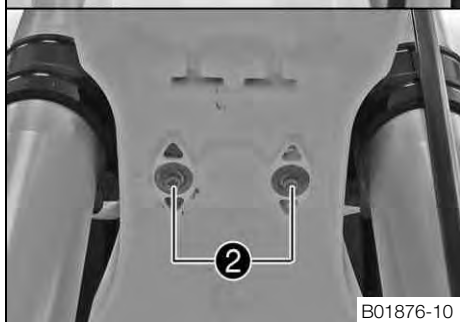
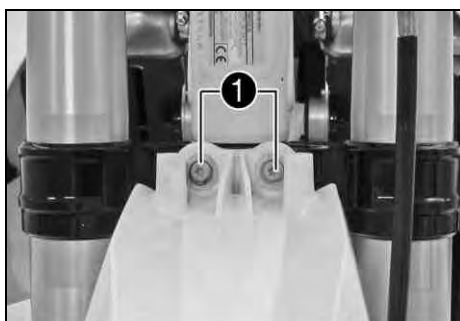

Finishing work

- Install the start number plate. (☛ p. 39)

11.20 Removing the shock absorber

Preparatory work

- Raise the motorcycle with the lift stand. (p. 32)

Main work

- Remove screw ①.
- Remove screw cap ②.

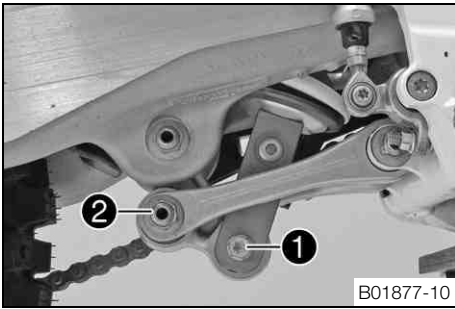

- Press angle lever ③ toward the rear.
- Press linkage lever ④ downward.

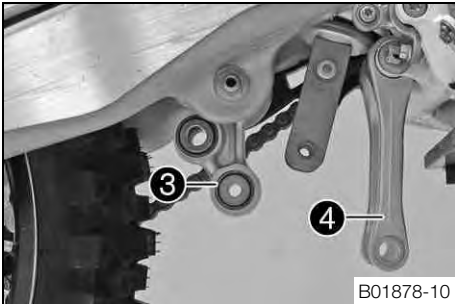

- Detach springs ⑤.

Spring hooks (50305017000)

- Remove screw ⑥ and take off the manifold.

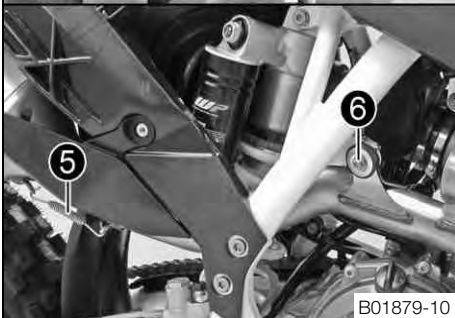
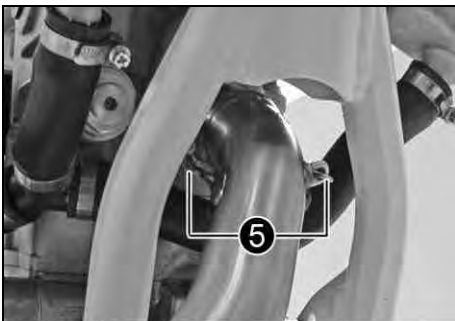

- Raise the swingarm.



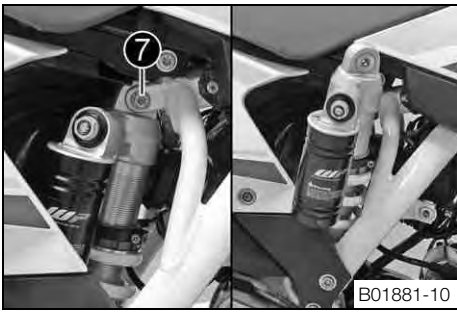

- Remove screw ⑦.
- Remove the shock absorber from the top.

11.21 Installing the shock absorber

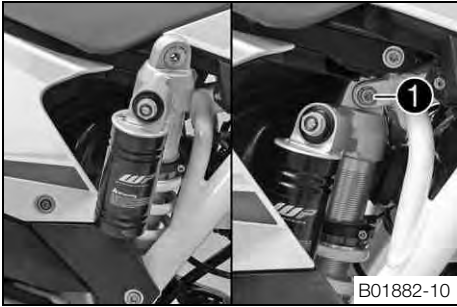

Main work

- Insert the shock absorber from above.
- Position the shock absorber.
- Mount and tighten screw ①.

Guideline

Screw, top shock absorber	M10	60 Nm (44.3 lbf ft)	Loctite® 2701™
---------------------------	-----	------------------------	-----------------------



- Lower the swingarm.

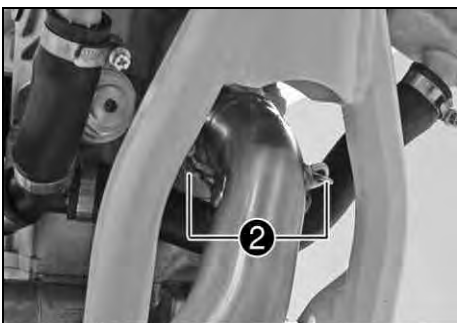

- Position the manifold.
- Attach springs ②.

Spring hooks (50305017000)

- Mount and tighten screw ③.

Guideline

Remaining screws, chassis	M8	25 Nm (18.4 lbf ft)
---------------------------	----	---------------------

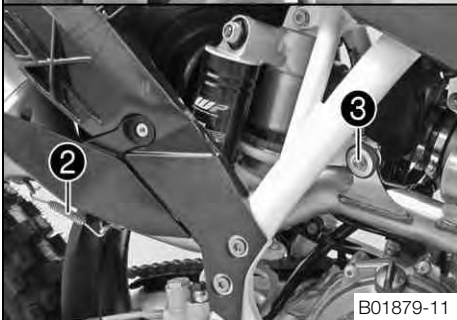

- Position the angle lever and linkage lever.
- Mount and tighten fitting ④.

Guideline

Nut, linkage lever to angle lever	M14x1.5	80 Nm (59 lbf ft)
-----------------------------------	---------	-------------------

- Mount and tighten screw ⑤.

Guideline

Screw, bottom shock absorber	M10	60 Nm (44.3 lbf ft)	Loctite® 2701™
------------------------------	-----	------------------------	-----------------------

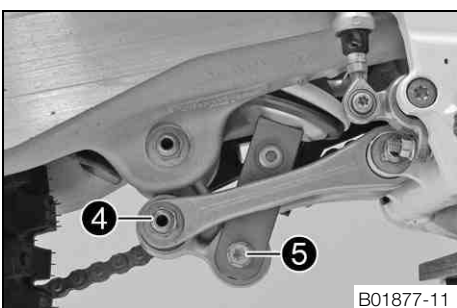

Finishing work

- Remove the motorcycle from the lift stand. (☛ p. 32)

11.22 Removing the seat

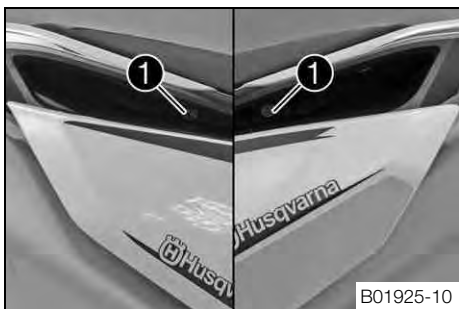

B01925-10

- Remove screws **1** in the recessed grips on the left and right.
- Lift up the seat at the rear, pull it back and then remove it from above.

11.23 Mounting the seat



B01884-01

- Hook in the front of the seat at the collar bushing of the fuel tank, lower it at the rear and simultaneously push it forward.
- Make sure that the seat is correctly locked in.
- Mount and tighten the screws for securing the seat.

Guideline

Remaining screws, chassis	M6	10 Nm (7.4 lbf ft)
---------------------------	----	--------------------

11.24 Removing the air filter box lid

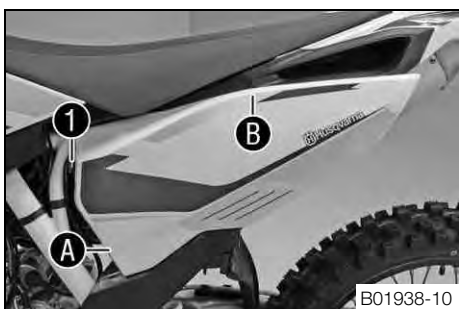

B01938-10

- Release catch **1**, pull off the air filter box lid sideways in areas **A** and **B** and remove toward the rear.

11.25 Installing the air filter box lid

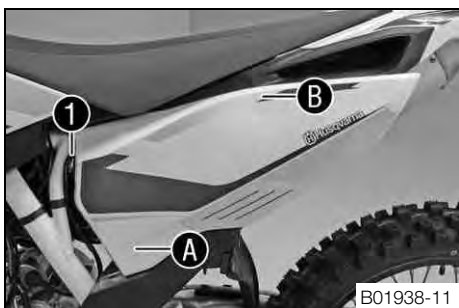

B01938-11

- Position the air filter box lid and tab **1**. Engage the air filter box lid in areas **A** and **B**.
- Engage tab **1**.

11.26 Removing the air filter 🛠️

Note

Engine failure Unfiltered intake air has a negative effect on the service life of the engine.

- Never ride the vehicle without an air filter since dust and dirt can get into the engine and result in increased wear.

Warning

Environmental hazard Hazardous substances cause environmental damage.

- Oil, grease, filters, fuel, cleaners, brake fluid, etc., should be disposed of as stipulated in applicable regulations.

Preparatory work

- Remove the air filter box lid. (🛠️ p. 42)

Main work

- Push air filter holder ① toward the air filter at position A and detach it at end B. Swing the air filter holder to one side and remove the air filter with the air filter support.
- Remove the air filter from the air filter support.

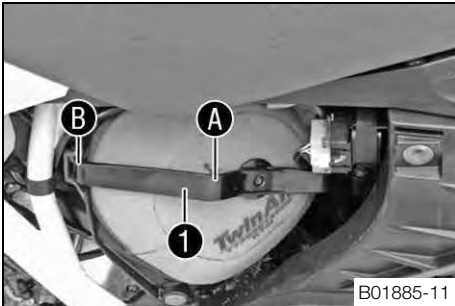

B01885-11

11.27 Installing the air filter 🛠️

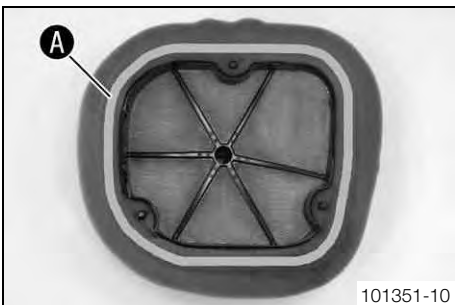

101351-10

Main work

- Mount the clean air filter on the air filter support.
- Grease the air filter in area A.

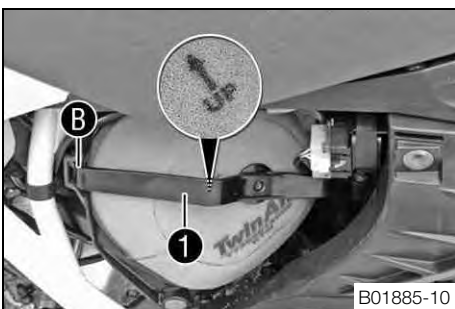

B01885-10

- Insert both parts together, position them, and fasten them using air filter holder ① in area B.

✓ The arrow of marking **UP** faces up.

Info

If the air filter is not correctly mounted, dust and dirt can enter the engine and cause damage.

Finishing work

- Install the air filter box lid. (🛠️ p. 42)

11.28 Cleaning the air filter and air filter box 🛠️

Warning

Environmental hazard Hazardous substances cause environmental damage.

- Oil, grease, filters, fuel, cleaners, brake fluid, etc., should be disposed of as stipulated in applicable regulations.

Info

Do not clean the air filter with fuel or petroleum since these substances attack the foam.

Preparatory work

- Remove the air filter box lid. (🛠️ p. 42)
- Remove the air filter. 🛠️ (🛠️ p. 43)



L00189-10

Main work

- Wash the air filter thoroughly in special cleaning liquid and allow it to dry properly.

Info

Only press the air filter to dry it, never wring it out.

- Oil the dry air filter with a high quality filter oil.
- Clean the air filter box.
- Check the intake flange for damage and looseness.

Finishing work

- Install the air filter. (☞ p. 43)
- Install the air filter box lid. (☞ p. 42)

11.29 Sealing the air filter box ☞

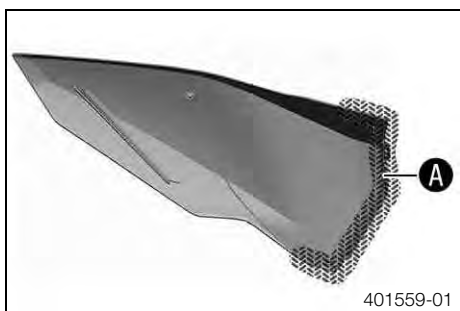

401559-01

- Seal the air filter box in the marked area **A**.

11.30 Removing the main silencer

Warning

Danger of burns The exhaust system gets very hot when the vehicle is driven.

- Allow the exhaust system to cool down. Do not touch hot components.

Preparatory work

- Remove the right side cover. (☞ p. 45)

Main work

- Disconnect spring **1**.
- Remove screws **2** and take off the main silencer.

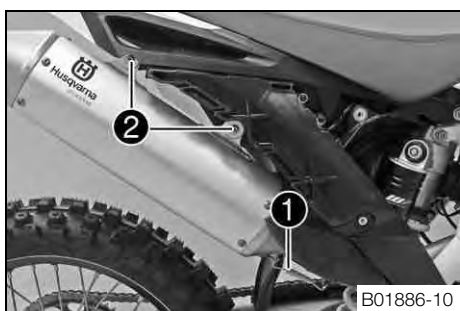

B01886-10

11.31 Installing the main silencer

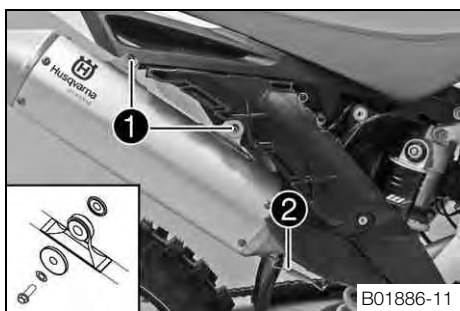

B01886-11

Main work

- Mount the main silencer. Mount screws **1** but do not tighten yet.
- Reconnect spring **2**.
- Tighten screws **1**.

Guideline

Remaining screws, chassis	M6	10 Nm (7.4 lbf ft)
---------------------------	----	--------------------

Finishing work

- Install the right side cover. (☞ p. 46)

11.32 Changing the glass fiber yarn filling of the main silencer

- Warning**
Danger of burns The exhaust system gets very hot when the vehicle is driven.
- Allow the exhaust system to cool down. Do not touch hot components.

- Info**
 Over time, the fibers of the glass fiber yarn escape and the damper "burns" out. Not only is the noise level higher, the performance characteristic changes.

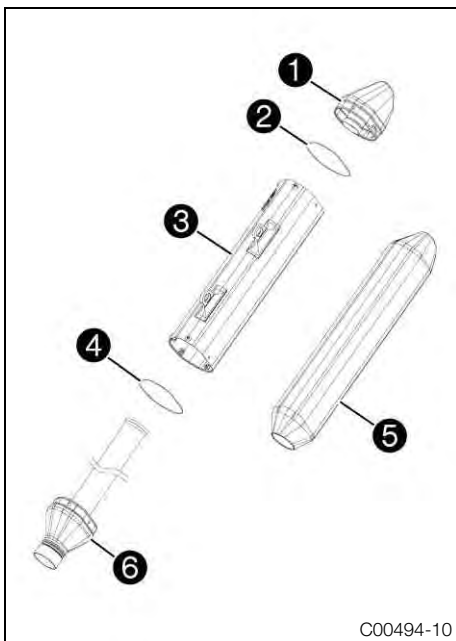

Preparatory work

- Remove the right side cover. (☛ p. 45)
- Remove the main silencer. (☛ p. 44)

Main work

- Remove all screws from the main silencer.
- Take off silencer cap 1 and O-ring 2.
- Take off outer tube 3 and O-ring 4.
- Pull the glass fiber yarn filling 5 from inner tube 6.
- Clean the parts that are to be reinstalled.
- Mount the new glass fiber yarn filling 5 on the inner tube.
- Slide O-ring 4 and outer tube 3 over the glass fiber yarn filling.
- Insert O-ring 2 and silencer cap 1 into the outer tube.
- Mount and tighten all screws.

Finishing work

- Install the main silencer. (☛ p. 44)
- Install the right side cover. (☛ p. 46)

11.33 Removing the right side cover



- Remove screw 1.
- Pull off the side cover in area A sideways and remove it toward the rear.

11.34 Installing the right side cover

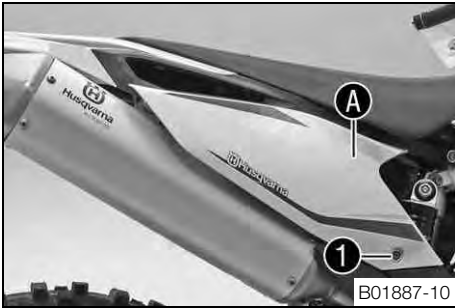

- Position the side cover and engage in area **A**.
- Mount and tighten screw **1**.

Guideline

Remaining screws, chassis	M6	10 Nm (7.4 lbf ft)
---------------------------	----	--------------------

11.35 Removing the fuel tank



Danger

Fire hazard Fuel is highly flammable.

- Never refuel the vehicle near open flames or burning cigarettes, and always switch off the engine first. Be careful that no fuel is spilt, especially on hot vehicle components. Clean up spilt fuel immediately.
- The fuel in the fuel tank expands when warm and may emerge if overfilled. Follow the instructions on refueling.



Warning

Danger of poisoning Fuel is poisonous and a health hazard.

- Fuel must not come into contact with the skin, eyes, or clothing. Do not breathe in the fuel vapors. If contact occurs with the eyes, rinse with water immediately and contact a physician. Immediately clean contaminated areas on the skin with soap and water. If fuel is swallowed, contact a physician immediately. Change clothing that is contaminated with fuel. Store fuel properly in a suitable canister and keep away from children.

Preparatory work

- Remove the seat. (☞ p. 42)

Main work

- Disconnect electric plug-in connection **1** of the fuel pump.
- Thoroughly clean plug-in connection **2** of the fuel line using compressed air.



Info

Under no circumstances should dirt enter into the fuel line. Dirt clogs the injection valve.

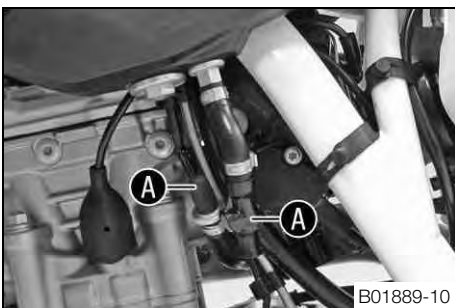
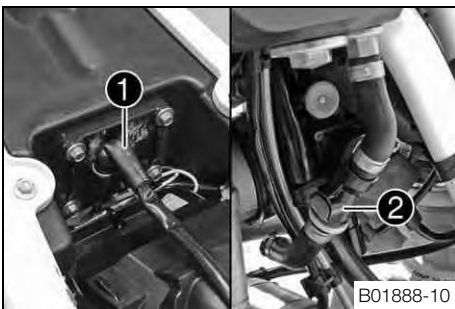

- Disconnect the plug-in connection of the fuel line.
- Mount wash cap set **A**.

Wash cap set (81212016100)

- Remove the tube from the fuel tank breather.

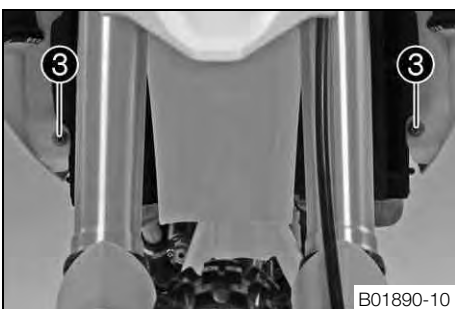

- Remove screws **3** with the collar bushing.

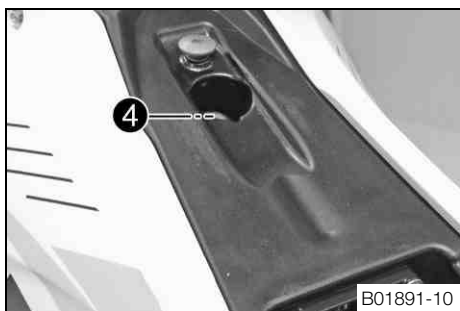

- Remove screw 4 with the rubber bushing.

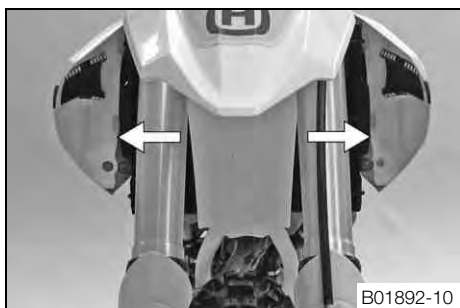

- Pull both spoilers off of the sides of the radiator bracket and lift off the fuel tank.

11.36 Installing the fuel tank



Danger

Fire hazard Fuel is highly flammable.

- Never refuel the vehicle near open flames or burning cigarettes, and always switch off the engine first. Be careful that no fuel is spilt, especially on hot vehicle components. Clean up spilt fuel immediately.
- The fuel in the fuel tank expands when warm and may emerge if overfilled. Follow the instructions on refueling.



Warning

Danger of poisoning Fuel is poisonous and a health hazard.

- Fuel must not come into contact with the skin, eyes, or clothing. Do not breathe in the fuel vapors. If contact occurs with the eyes, rinse with water immediately and contact a physician. Immediately clean contaminated areas on the skin with soap and water. If fuel is swallowed, contact a physician immediately. Change clothing that is contaminated with fuel.

Main work

- Check the throttle cable routing. (☛ p. 52)
- Position the fuel tank and fit the two spoilers to the sides of the radiator bracket.
- Make sure that no cables are trapped or damaged.
- Mount the fuel tank breather.
- Mount and tighten screw 1 with the rubber bushing.

Guideline

Remaining screws, chassis	M6	10 Nm (7.4 lbf ft)
---------------------------	----	--------------------

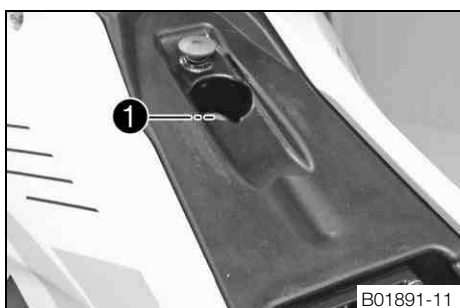

- Mount and tighten screws 2 with the collar bushing.

Guideline

Remaining screws, chassis	M6	10 Nm (7.4 lbf ft)
---------------------------	----	--------------------

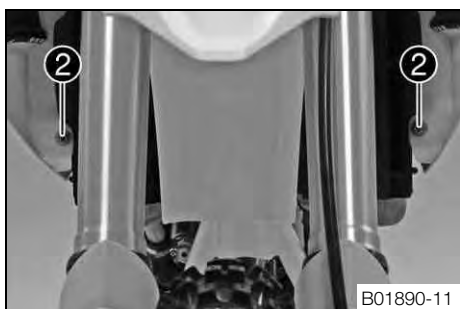

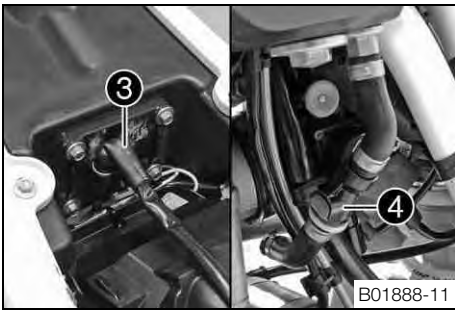

- Connect the electrical plug-in connection **3**.
- Remove the wash cap set and clean the plug-in connection of the fuel line thoroughly with compressed air.

i Info

Under no circumstances should dirt enter into the fuel line. Dirt in the fuel line clogs the injection valve.

- Lubricate the O-ring and connect plug-in connection **4** of the fuel line.

i Info

Route the cable and fuel line at a safe distance from the exhaust system.

Finishing work

- Mount the seat. (☛ p. 42)

11.37 Checking for chain dirt accumulation

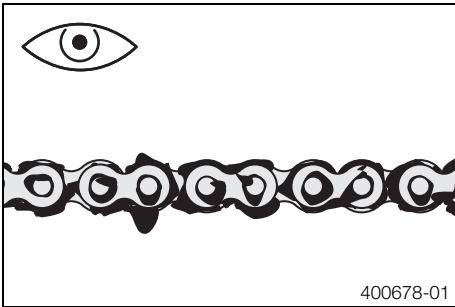

- Check the chain for coarse dirt accumulation.
 - » If the chain is very dirty:
 - Clean the chain. (☛ p. 48)

11.38 Cleaning the chain

⚠ Warning

Danger of accidents Oil or grease on the tires reduces their grip.

- Remove oil and grease with a suitable cleaning material.

⚠ Warning

Danger of accidents Reduced braking efficiency due to oil or grease on the brake discs.

- Always keep the brake discs free of oil and grease, and clean them with brake cleaner when necessary.

☀ Warning

Environmental hazard Hazardous substances cause environmental damage.

- Oil, grease, filters, fuel, cleaners, brake fluid, etc., should be disposed of as stipulated in applicable regulations.

i Info

The service life of the chain depends largely on its maintenance.

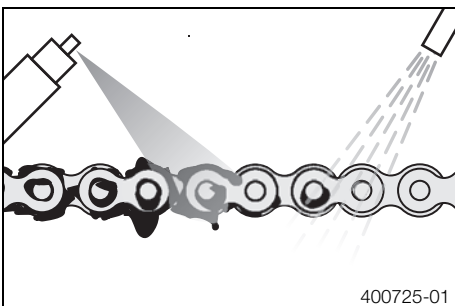

- Clean the chain regularly and then treat with chain spray.

11.39 Checking the chain tension

Warning
Danger of accidents Danger caused by incorrect chain tension.

- If the chain is too taut, the components of the secondary power transmission (chain, engine sprocket, rear sprocket, bearings in the transmission and in the rear wheel) will be under additional load. In addition to premature wear, this can cause the chain or the countershaft of the transmission to break in extreme cases. If the chain is too loose, however, it may fall off the engine sprocket or rear sprocket and block the rear wheel or damage the engine. Ensure that the chain tension is correct and adjust it if necessary.

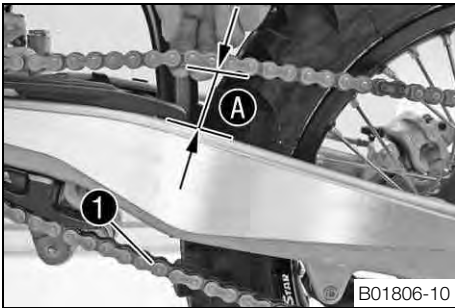

Preparatory work

- Raise the motorcycle with the lift stand. (☛ p. 32)

Main work

- Push the chain at the end of the chain sliding component upwards to measure the chain tension **A**.

Info

The lower chain section **1** must be taut.
 Chain wear is not always even, so you should repeat this measurement at different chain positions.

Chain tension	55... 58 mm (2.17... 2.28 in)
---------------	-------------------------------

- » If the chain tension does not meet specifications:
 - Adjust the chain tension. (☛ p. 49)

Finishing work

- Remove the motorcycle from the lift stand. (☛ p. 32)

11.40 Adjusting the chain tension

Warning
Danger of accidents Danger caused by incorrect chain tension.

- If the chain is too taut, the components of the secondary power transmission (chain, engine sprocket, rear sprocket, bearings in the transmission and in the rear wheel) will be under additional load. In addition to premature wear, this can cause the chain or the countershaft of the transmission to break in extreme cases. If the chain is too loose, however, it may fall off the engine sprocket or rear sprocket and block the rear wheel or damage the engine. Ensure that the chain tension is correct and adjust it if necessary.

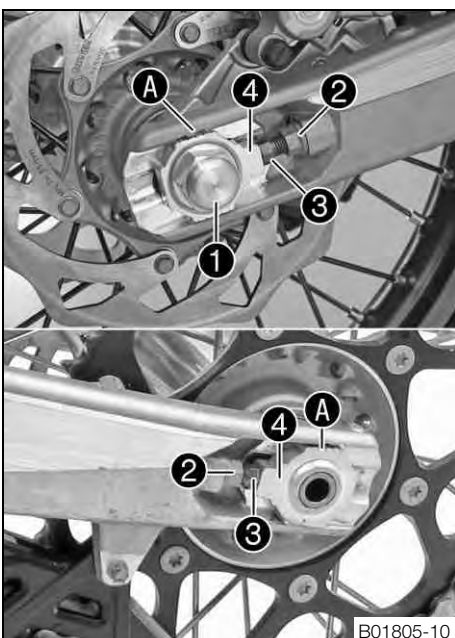

Preparatory work

- Raise the motorcycle with the lift stand. (☛ p. 32)
- Check the chain tension. (☛ p. 49)

Main work

- Loosen nut **1**.
- Loosen nuts **2**.
- Adjust the chain tension by turning the adjusting screws **3** left and right.

Guideline

Chain tension	55... 58 mm (2.17... 2.28 in)
Turn adjusting screws 3 on the left and right so that the markings on the left and right chain adjusters are in the same position relative to the reference marks A . The rear wheel is then correctly aligned.	

- Tighten nuts **2**.
- Make sure that chain adjusters **4** are fitted correctly on adjusting screws **3**.
- Tighten nut **1**.

Guideline

Nut, rear wheel spindle	M20x1.5	80 Nm (59 lbf ft)
-------------------------	---------	-------------------

i Info
 The wide adjustment range of the chain adjusters (32 mm (1.18 in)) enables different secondary ratios with the same chain length.
 Chain adjusters ④ can be turned by 180°.

Finishing work

- Remove the motorcycle from the lift stand. (☛ p. 32)

11.41 Checking the chain, rear sprocket, engine sprocket and chain guide

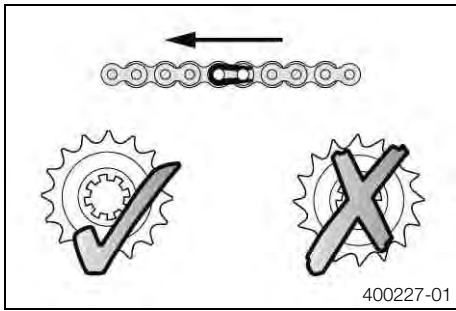

Preparatory work

- Raise the motorcycle with the lift stand. (☛ p. 32)

Main work

- Shift gear to neutral.
- Check the rear sprocket and engine sprocket for wear.
 - » If the rear sprocket and engine sprocket are worn:
 - Change the power set. ☛

i Info
 The engine sprocket, rear sprocket and chain should always be replaced together.

- Pull on the upper part of the chain with the specified weight **A**.

Guideline

Weight, chain wear measurement	10... 15 kg (22... 33 lb.)
--------------------------------	----------------------------

- Measure the distance **B** of 18 chain rollers in the lower chain section.

i Info
 Chain wear is not always even, so you should repeat this measurement at different chain positions.

Maximum distance B at the longest chain section	272 mm (10.71 in)
--	-------------------

- » If the distance **B** is greater than the specified measurement:
 - Change the power set. ☛

i Info
 When the chain is replaced, the rear sprocket and engine sprocket should also be changed.
 New chains wear out faster on old, worn sprockets.

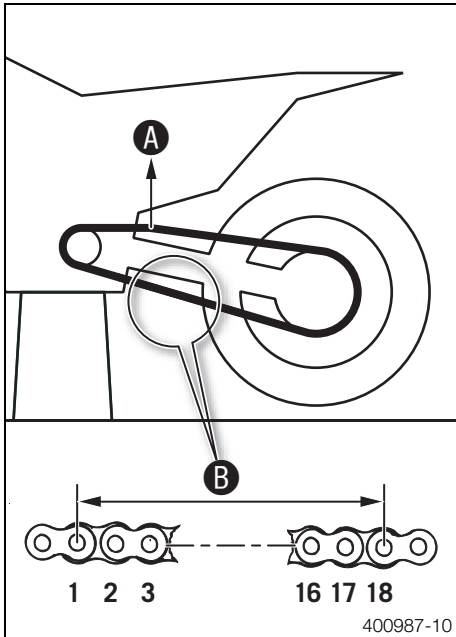

- Check the chain sliding guard for wear.
 - » If the bottom edge of the chain pin is in line with or below the chain sliding guard:
 - Change the chain sliding guard. ☛
- Check that the chain sliding guard is firmly seated.
 - » If the chain sliding guard is loose:
 - Tighten the chain sliding guard.

Guideline

Screw, chain sliding guard	M6	6 Nm (4.4 lbf ft)	Loctite® 243™
----------------------------	----	-------------------	----------------------

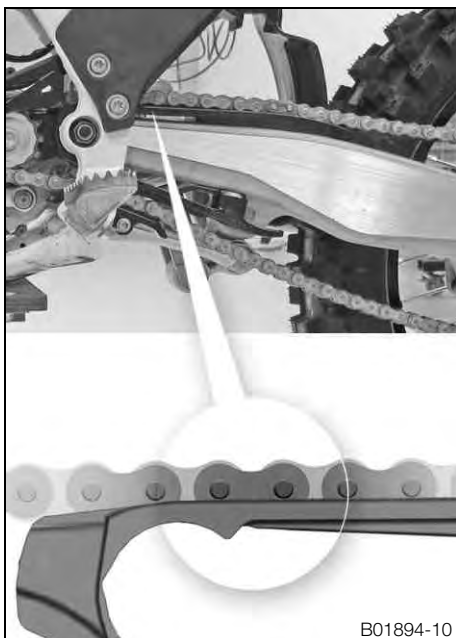



- Check the chain sliding piece for wear.
 - » If the bottom edge of the chain pin is in line with or below the chain sliding piece:
 - Change the chain sliding piece. 🛠️
- Check that the chain sliding piece is firmly seated.
 - » If the chain sliding piece is loose:
 - Tighten the chain sliding piece.

Guideline

Screw, chain sliding piece	M8	15 Nm (11.1 lbf ft)
----------------------------	----	------------------------

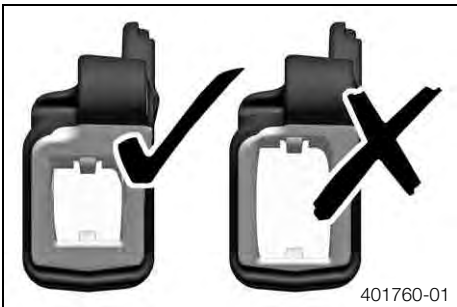

- Check the chain guide for wear.

i Info

Wear can be seen on the front of the chain guide.

- » If the light part of the chain guide is worn:
 - Change the chain sliding piece. 🛠️

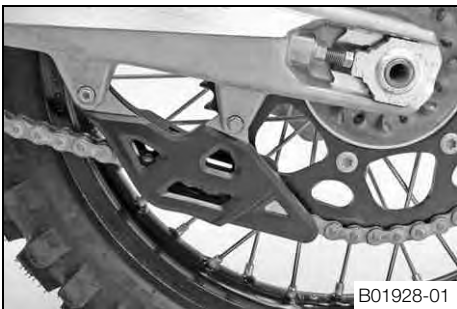

- Check that the chain guide is firmly seated.
 - » If the chain guide is loose:
 - Tighten the chain guide.

Guideline

Remaining screws, chassis	M6	10 Nm (7.4 lbf ft)
---------------------------	----	--------------------

Finishing work

- Remove the motorcycle from the lift stand. (🔧 p. 32)

11.42 Checking the frame 🛠️



- Check the frame for cracking and deformation.
 - » If the frame exhibits cracking or deformation due to a mechanical impact:
 - Change the frame. 🛠️

i Info

A frame that has been damaged due to a mechanical impact must always be changed. Repair of the frame is not authorized by Husqvarna.

11.43 Checking the swingarm



- Check the swingarm for damage, cracking, and deformation.
 - » If the swingarm shows signs of damage, cracking, or deformation:
 - Change the swingarm. 





Info

A damaged swingarm must always be changed. Repair of the swingarm is not authorized by Husqvarna.

11.44 Checking the throttle cable routing

Preparatory work

- Remove the seat. ( p. 42)
- Remove the fuel tank.  ( p. 46)

Main work



- Check the throttle cable routing.

Both throttle cables must be routed to the throttle valve body side by side behind the handlebars and above the fuel tank bearing.

- » If the throttle cable is not routed as specified:
 - Correct the throttle cable routing.



Finishing work

- Install the fuel tank.  ( p. 47)
- Mount the seat. ( p. 42)

11.45 Checking the rubber grip

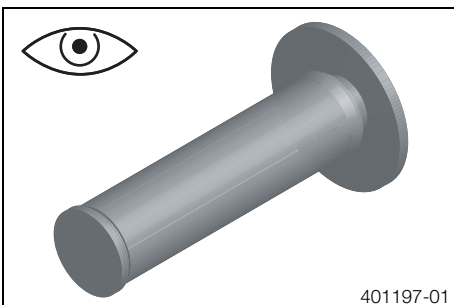

- Check the rubber grips on the handlebar for damage and wear and to ensure they are firmly seated.
 - » If a rubber grip is damaged, worn or loose:
 - Change and secure the rubber grip.

Rubber grip adhesive (00062030051) ( p. 93)

11.46 Additionally securing the rubber grip

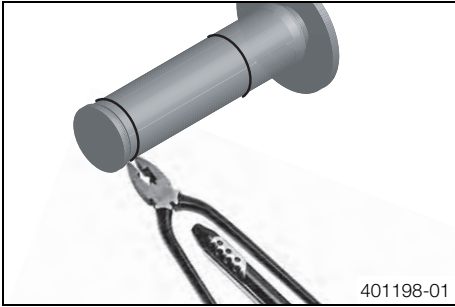

Preparatory work

- Check the rubber grip. (☛ p. 52)

Main work

- Secure the rubber grip at two points using the securing wire.

Securing wire (54812016000)

Wire twister forceps (U6907854)

- ✓ The twisted wire ends face away from the hands and are bent toward the rubber grip.

11.47 Adjusting the basic position of the clutch lever



- Adjust the basic setting of the clutch lever to your hand size by turning adjusting screw ①.

i Info

Turn the adjusting screw counterclockwise to decrease the distance between the clutch lever and the handlebar.

Turn the adjusting screw clockwise to increase the distance between the clutch lever and the handlebar.

The range of adjustment is limited.

Turn the adjusting screw by hand only, and do not apply any force.

Do not make any adjustments while riding!

11.48 Checking/rectifying the fluid level of the hydraulic clutch

i Info

The fluid level rises with increased wear of the clutch lining discs.

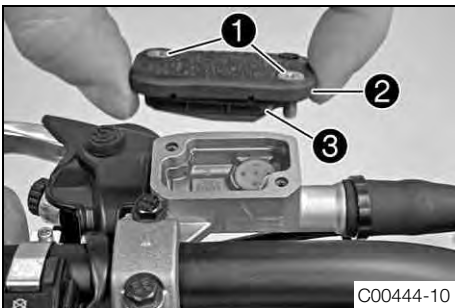

- Move the clutch fluid reservoir mounted on the handlebar to a horizontal position.
- Remove screws ①.
- Remove cover ② with membrane ③.
- Check the fluid level.

Fluid level below container rim	4 mm (0.16 in)
---------------------------------	----------------

» If the fluid level does not meet specifications:

- Correct the fluid level of the hydraulic clutch.

Brake fluid DOT 4 / DOT 5.1 (☛ p. 91)

- Position the cover with the membrane. Mount and tighten the screws.

i Info

Clean up overflowed or spilt brake fluid immediately with water.

11.49 Changing the hydraulic clutch fluid ☞

Warning

Environmental hazard Hazardous substances cause environmental damage.

- Oil, grease, filters, fuel, cleaners, brake fluid, etc., should be disposed of as stipulated in applicable regulations.

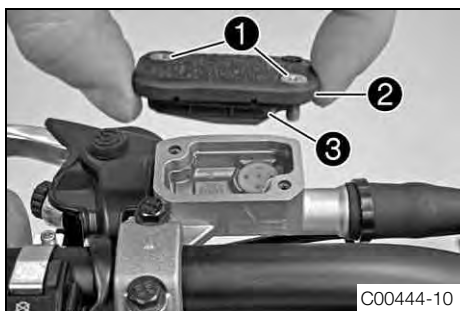

- Move the clutch fluid reservoir mounted on the handlebar to a horizontal position.
- Remove screws ①.
- Remove cover ② with membrane ③.

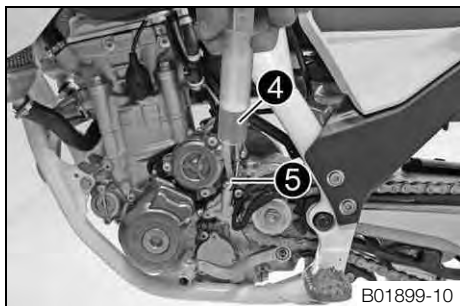

- Fill bleeding syringe ④ with the appropriate hydraulic fluid.

Bleed syringe (50329050000)
Brake fluid DOT 4 / DOT 5.1 (☞ p. 91)

- Mount bleeding syringe ④ on bleeder screw ⑤ with a suitable hose piece.
- On the clutch slave cylinder, only release bleeder screw ⑤ to the point where filling is possible.

i Info

Wash off overflowing or spilled brake fluid immediately with water. Avoid contact between brake fluid and painted parts. Brake fluid attacks paint. Use only clean brake fluid from a sealed container.

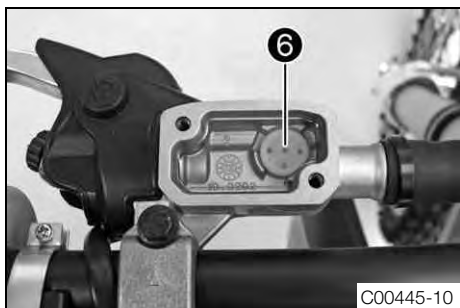

- Inject the liquid into the system until it escapes from openings ⑥ of the master cylinder without bubbles.
- To prevent overflow, drain fluid occasionally from the master cylinder reservoir.
- Tighten the bleeder screw and remove the bleeding syringe with the hose.
- Correct the fluid level of the hydraulic clutch.

Guideline

Fluid level below container rim	4 mm (0.16 in)
---------------------------------	----------------

- Position the cover with the membrane. Mount and tighten the screws.

12.1 Checking the free travel of the hand brake lever

Warning
Danger of accidents Brake system failure.

- If there is no free travel on the hand brake lever, pressure builds up on the front brake circuit. The front brake can fail due to overheating. Adjust the free travel on hand brake lever according to specifications.



- Push the hand brake lever forward and check free travel **A**.

Free travel of hand brake lever	$\geq 3 \text{ mm } (\geq 0.12 \text{ in})$
---------------------------------	---

- » If the free travel does not meet specifications:
 - Adjust the basic position of the hand brake lever. (☛ p. 55)

12.2 Adjusting the basic position of the hand brake lever

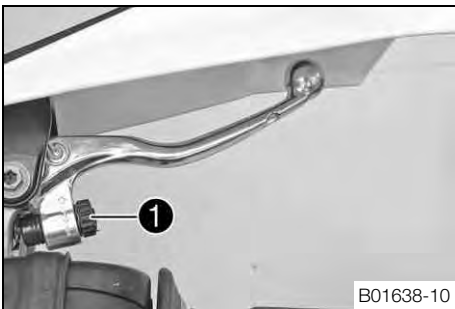

- Check the free travel of the hand brake lever. (☛ p. 55)
- Adjust the basic setting of the hand brake lever to your hand size by turning adjusting screw **1**.

i Info
 Turn the adjusting screw clockwise to increase the distance between the hand brake lever and the handlebar.
 Turn the adjusting screw counterclockwise to decrease the distance between the hand brake lever and the handlebar.
 The range of adjustment is limited.
 Turn the adjusting screw by hand only, and do not apply any force.
 Do not make any adjustments while riding!

12.3 Checking the brake discs

Warning
Danger of accidents Reduced braking efficiency due to worn brake disc(s).

- Change the worn brake disc(s) without delay. (Your authorized Husqvarna workshop will be glad to help.)

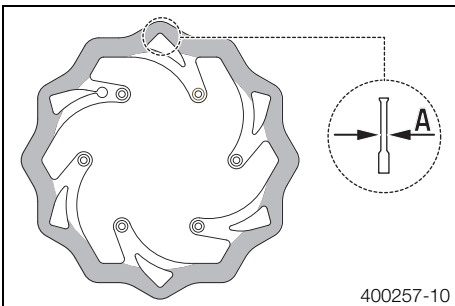

- Check the thickness of the front and rear brake discs at several places on the disk to see if it conforms to measurement **A**.

i Info
 Wear reduces the thickness of the brake disc around the area used by the brake linings.

Brake discs - wear limit	
Front	2.5 mm (0.098 in)
Rear	3.5 mm (0.138 in)

- » If the brake disc thickness is less than the specified value:
 - Change the brake disc.
- Check the front and rear brake discs for damage, cracking and deformation.
 - » If the brake disc shows signs of damage, cracking or deformation:
 - Change the brake disc.

12.4 Checking the front brake fluid level

- Warning**
Danger of accidents Brake system failure.
- If the brake fluid level drops below the specified marking or the specified value, this is an indication that the brake system is leaking or that the brake linings are completely worn down. Check the brake system and do not continue riding. (Your authorized Husqvarna workshop will be glad to help.)

- Warning**
Danger of accidents Reduced braking efficiency due to old brake fluid.
- Change the brake fluid of the front and rear brake according to the service schedule. (Your authorized Husqvarna workshop will be glad to help.)

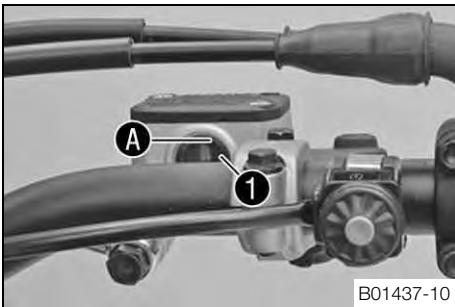

Preparatory work

- Check the front brake linings. (☞ p. 57)

Main work

- Move the brake fluid reservoir mounted on the handlebar to a horizontal position.
- Check the brake fluid level in level viewer ①.
 - » If the brake fluid has dropped below marking A:
 - Add front brake fluid. ☞ (☞ p. 56)

12.5 Adding front brake fluid ☞

- Warning**
Danger of accidents Brake system failure.
- If the brake fluid level drops below the specified marking or the specified value, this is an indication that the brake system is leaking or that the brake linings are completely worn down. Check the brake system and do not continue riding. (Your authorized Husqvarna workshop will be glad to help.)

- Warning**
Skin irritation Brake fluid can cause skin irritation on contact.
- Avoid contact with skin and eyes, and keep out of the reach of children.
 - Wear suitable protective clothing and goggles.
 - If brake fluid comes into contact with the eyes, flush the eyes thoroughly with water and consult a physician immediately.

- Warning**
Danger of accidents Reduced braking efficiency due to old brake fluid.
- Change the brake fluid of the front and rear brake according to the service schedule. (Your authorized Husqvarna workshop will be glad to help.)

- Warning**
Environmental hazard Hazardous substances cause environmental damage.
- Oil, grease, filters, fuel, cleaners, brake fluid, etc., should be disposed of as stipulated in applicable regulations.

- i Info**
- Never use DOT 5 brake fluid! It is silicone-based and purple in color. Oil seals and brake lines are not designed for DOT 5 brake fluid.
- Avoid contact between brake fluid and painted parts. Brake fluid attacks paint.
- Use only clean brake fluid from a sealed container.

Preparatory work

- Check the front brake linings. (☞ p. 57)

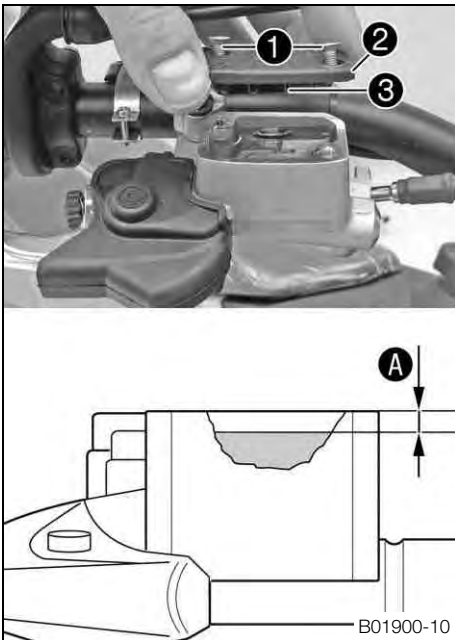

Main work

- Move the brake fluid reservoir mounted on the handlebar to a horizontal position.
- Remove screws ①.
- Remove cover ② with membrane ③.
- Add brake fluid to level A.

Guideline

Dimension A (brake fluid level below top edge of container)	5 mm (0.2 in)
---	---------------

Brake fluid DOT 4 / DOT 5.1 (☞ p. 91)

- Position the cover with the membrane. Mount and tighten the screws.

Info

Clean up overflowed or spilt brake fluid immediately with water.

12.6 Checking the front brake linings

Warning

Danger of accidents Reduced braking efficiency caused by worn brake linings.

- Change worn brake linings immediately. (Your authorized Husqvarna workshop will be glad to help.)

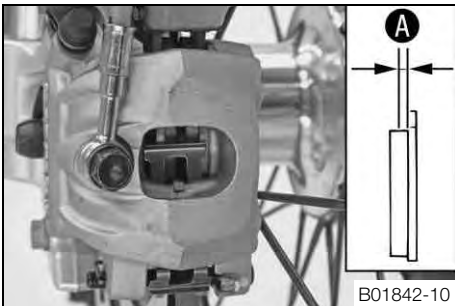

- Check the brake linings for minimum thickness A.

Minimum thickness A	$\geq 1 \text{ mm } (\geq 0.04 \text{ in})$
---------------------	---

- » If the minimum thickness is less than specified:
 - Change the front brake linings. ☞ (☞ p. 57)
- Check the brake linings for damage and cracking.
 - » If damage or cracking is visible:
 - Change the front brake linings. ☞ (☞ p. 57)

12.7 Changing the front brake linings ☞

Warning

Danger of accident Brake system failure.

- Maintenance work and repairs must be carried out professionally. (Your authorized Husqvarna workshop will be glad to help.)

Warning

Skin irritation Brake fluid can cause skin irritation on contact.

- Avoid contact with skin and eyes, and keep out of the reach of children.
- Wear suitable protective clothing and goggles.
- If brake fluid comes into contact with the eyes, flush the eyes thoroughly with water and consult a physician immediately.

Warning

Danger of accidents Reduced braking efficiency due to old brake fluid.

- Change the brake fluid of the front and rear brake according to the service schedule. (Your authorized Husqvarna workshop will be glad to help.)

Warning

Environmental hazard Hazardous substances cause environmental damage.

- Oil, grease, filters, fuel, cleaners, brake fluid, etc., should be disposed of as stipulated in applicable regulations.

i Info

Never use DOT 5 brake fluid! It is silicone-based and purple in color. Oil seals and brake lines are not designed for DOT 5 brake fluid.

Avoid contact between brake fluid and painted parts. Brake fluid attacks paint!

Use only clean brake fluid from a sealed container.

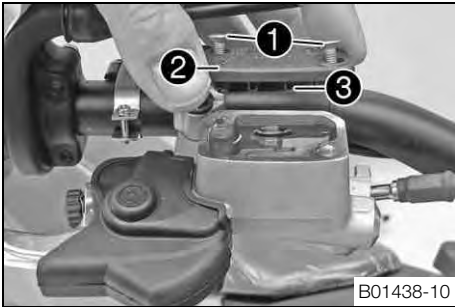

- Move the brake fluid reservoir mounted on the handlebar to a horizontal position.
- Remove screws **1**.
- Remove cover **2** with membrane **3**.

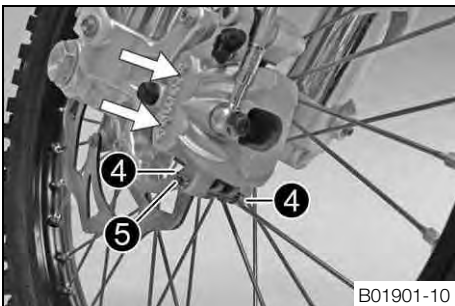

- Manually press the brake caliper to the brake disc to push back the brake pistons. Ensure that brake fluid does not flow out of the brake fluid reservoir, extracting it by suction if it does.

i Info

Make sure when pushing back the brake pistons that you do not press the brake caliper against the spokes.

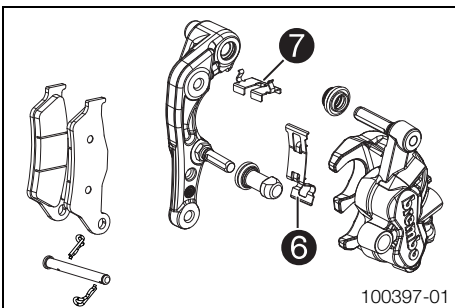

- Remove cotter pin **4**, pull out pin **5**, and remove the brake linings.
- Clean the brake caliper and brake caliper support.
- Check that leaf spring **6** in the brake caliper and sliding plate **7** in the brake caliper support are seated correctly.

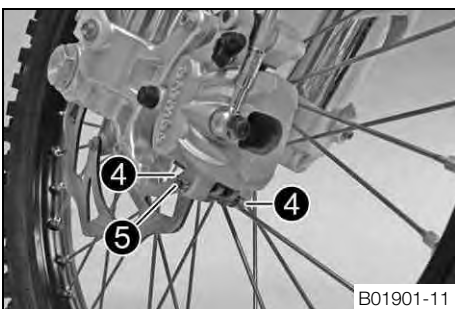

- Insert the new brake linings, insert pin **5**, and mount cotter pins **4**.

i Info

Always change the brake linings in pairs.

- Operate the hand brake lever repeatedly until the brake linings are in contact with the brake disc and there is a pressure point.

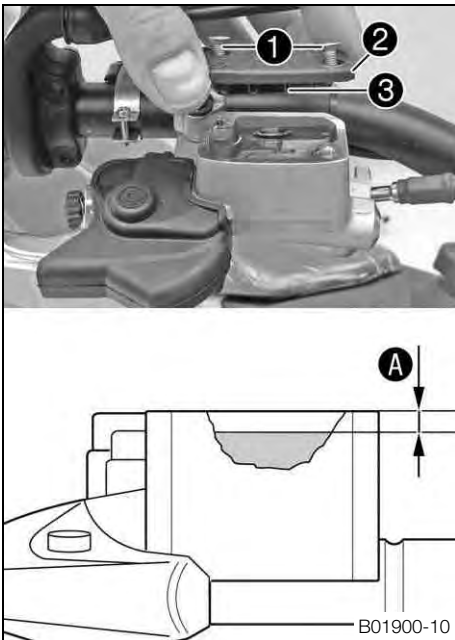

- Add brake fluid to level **A**.

Guideline

Dimension A (brake fluid level below top edge of container)	5 mm (0.2 in)
--	---------------

Brake fluid DOT 4 / DOT 5.1 (☞ p. 91)

- Position cover **2** with membrane **3**.
- Mount and tighten screws **1**.

i Info
Clean up overflowed or spilt brake fluid immediately with water.

12.8 Checking the free travel of foot brake lever

Warning
Danger of accidents Brake system failure.

- If there is no free travel on the foot brake lever, pressure builds up on the rear brake circuit. The rear brake can fail due to overheating. Adjust the free travel on foot brake lever according to specifications.

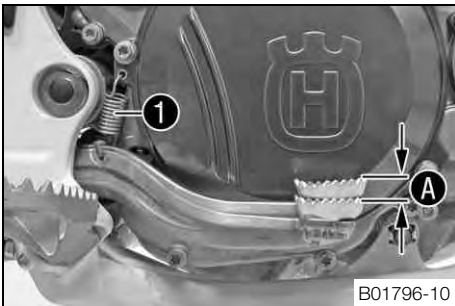

- Disconnect spring **1**.
- Move the foot brake lever back and forth between the end stop and the contact to the foot brake cylinder piston and check free travel **A**.

Guideline

Free travel at foot brake lever	3... 5 mm (0.12... 0.2 in)
---------------------------------	----------------------------

- » If the free travel does not meet specifications:
 - Adjust the basic position of the foot brake lever. ☞ (☞ p. 59)
- Reconnect spring **1**.

12.9 Adjusting the basic position of the foot brake lever ☞

Warning
Danger of accidents Brake system failure.

- If there is no free travel on the foot brake lever, pressure builds up on the rear brake circuit. The rear brake can fail due to overheating. Adjust the free travel on foot brake lever according to specifications.

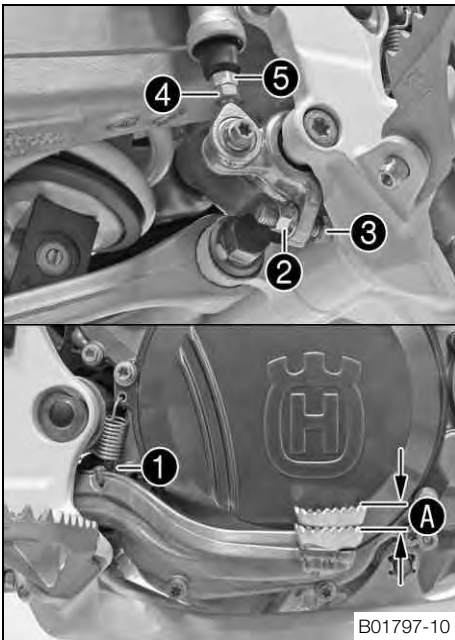

- Disconnect spring ①.
- Loosen nut ④ and, with push rod ⑤, turn it back until you have maximum free travel.
- To adjust the basic position of the foot brake lever individually, loosen nut ② and turn screw ③ accordingly.



Info

The range of adjustment is limited.

- Turn push rod ⑤ accordingly until you have free travel A. If necessary, adjust the basic position of the foot brake lever.

Guideline

Free travel at foot brake lever	3... 5 mm (0.12... 0.2 in)
---------------------------------	----------------------------

- Hold push rod ⑤ and tighten nut ④.

Guideline

Remaining nuts, chassis	M6	10 Nm (7.4 lbf ft)
-------------------------	----	--------------------

- Hold screw ③ and tighten nut ②.

Guideline

Nut, foot brake lever stop	M8	20 Nm (14.8 lbf ft)
----------------------------	----	---------------------

- Reconnect spring ①.

12.10 Checking the rear brake fluid level



Warning

Danger of accidents Brake system failure.

- If the brake fluid level drops below the specified marking or the specified value, this is an indication that the brake system is leaking or that the brake linings are completely worn down. Check the brake system and do not continue riding. (Your authorized Husqvarna workshop will be glad to help.)



Warning

Danger of accidents Reduced braking efficiency due to old brake fluid.

- Change the brake fluid of the front and rear brake according to the service schedule. (Your authorized Husqvarna workshop will be glad to help.)

Preparatory work

- Check the rear brake linings. (☞ p. 61)

Main work

- Stand the vehicle upright.
- Check the brake fluid level in level viewer ①.
 - » If the brake fluid has dropped below marking A:
 - Add rear brake fluid. ☞ (☞ p. 60)

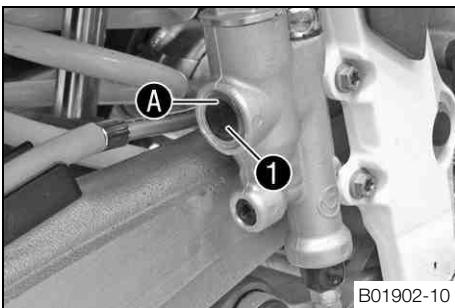

12.11 Adding rear brake fluid ☞



Warning

Danger of accidents Brake system failure.

- If the brake fluid level drops below the specified marking or the specified value, this is an indication that the brake system is leaking or that the brake linings are completely worn down. Check the brake system and do not continue riding. (Your authorized Husqvarna workshop will be glad to help.)

- Warning**
Skin irritation Brake fluid can cause skin irritation on contact.
- Avoid contact with skin and eyes, and keep out of the reach of children.
 - Wear suitable protective clothing and goggles.
 - If brake fluid comes into contact with the eyes, flush the eyes thoroughly with water and consult a physician immediately.

- Warning**
Danger of accidents Reduced braking efficiency due to old brake fluid.
- Change the brake fluid of the front and rear brake according to the service schedule. (Your authorized Husqvarna workshop will be glad to help.)

- Warning**
Environmental hazard Hazardous substances cause environmental damage.
- Oil, grease, filters, fuel, cleaners, brake fluid, etc., should be disposed of as stipulated in applicable regulations.

- Info**
 Never use DOT 5 brake fluid! It is silicone-based and purple in color. Oil seals and brake lines are not designed for DOT 5 brake fluid.
 Avoid contact between brake fluid and painted parts. Brake fluid attacks paint!
 Use only clean brake fluid from a sealed container.

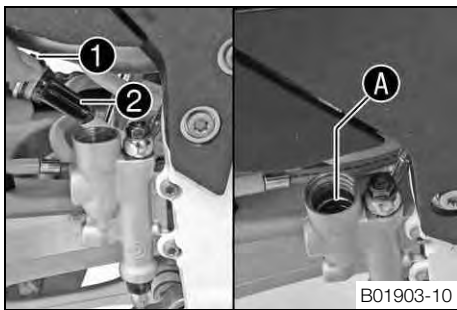

Preparatory work

- Check the rear brake linings. (☛ p. 61)

Main work

- Stand the vehicle upright.
- Remove screw cap 1 with membrane 2 and the O-ring.
- Add brake fluid to level A.

Brake fluid DOT 4 / DOT 5.1 (☛ p. 91)

- Mount and tighten the screw cap with the membrane and O-ring.

- Info**
 Clean up overflowed or spilt brake fluid immediately with water.

12.12 Checking the rear brake linings

- Warning**
Danger of accidents Reduced braking efficiency caused by worn brake linings.
- Change worn brake linings immediately. (Your authorized Husqvarna workshop will be glad to help.)

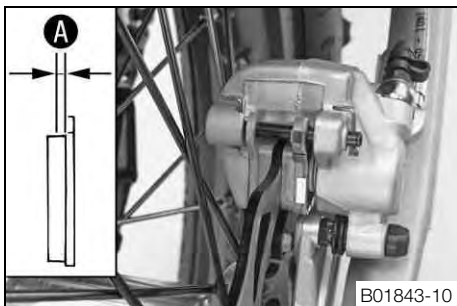

- Check the brake linings for minimum thickness A.

Minimum thickness A $\geq 1 \text{ mm } (\geq 0.04 \text{ in})$

- » If the minimum thickness is less than specified:
 - Change the rear brake linings. ☛ (☛ p. 62)
- Check the brake linings for damage and cracking.
 - » If damage or cracking is visible:
 - Change the rear brake linings. ☛ (☛ p. 62)

12.13 Changing the rear brake linings

Warning
Danger of accident Brake system failure.

- Maintenance work and repairs must be carried out professionally. (Your authorized Husqvarna workshop will be glad to help.)

Warning
Skin irritation Brake fluid can cause skin irritation on contact.

- Avoid contact with skin and eyes, and keep out of the reach of children.
- Wear suitable protective clothing and goggles.
- If brake fluid comes into contact with the eyes, flush the eyes thoroughly with water and consult a physician immediately.

Warning
Danger of accidents Reduced braking efficiency due to old brake fluid.

- Change the brake fluid of the front and rear brake according to the service schedule. (Your authorized Husqvarna workshop will be glad to help.)

 **Warning**
Environmental hazard Hazardous substances cause environmental damage.

- Oil, grease, filters, fuel, cleaners, brake fluid, etc., should be disposed of as stipulated in applicable regulations.

i Info
 Never use DOT 5 brake fluid. It is silicone-based and purple in color. Oil seals and brake lines are not designed for DOT 5 brake fluid.
 Avoid contact between brake fluid and painted parts. Brake fluid attacks paint!
 Use only clean brake fluid from a sealed container.

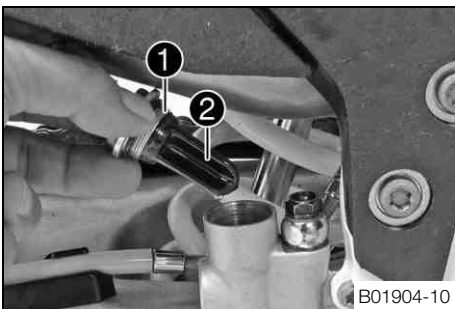

- Stand the vehicle upright.
- Remove screw cap **1** with membrane **2** and the O-ring.

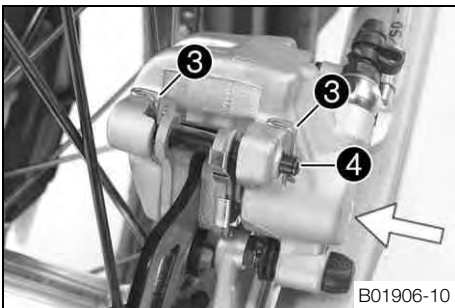

- Press the brake caliper onto the brake disc by hand in order to push back the brake piston and ensure that brake fluid does not flow out of the brake fluid reservoir, extracting it by suction if it does.

i Info
 Ensure that the brake caliper is not pressed against the spokes when pushing back the brake piston.

- Remove cotter pins **3**, pull out pin **4**, and remove the brake linings.
- Clean the brake caliper and brake caliper support.

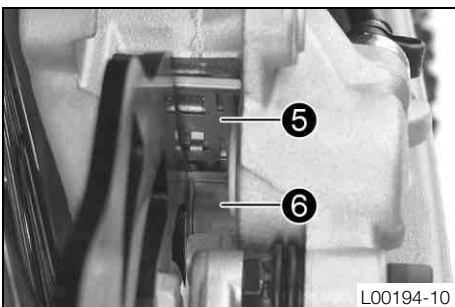

- Check that leaf spring **5** in the brake caliper and sliding plate **6** in the brake caliper support are seated properly.

i Info
 The arrow on the leaf spring points in the rotation direction of the brake disc.

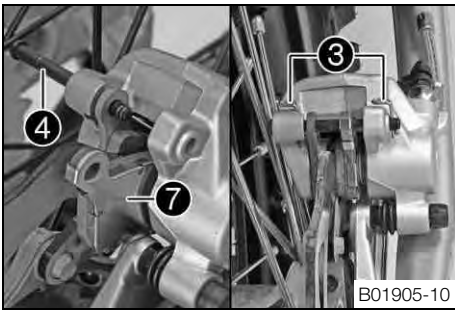

- Insert the new brake linings, insert pin 4, and mount cotter pins 3.



Info

Always change the brake linings in pairs.



Info

Make sure that decoupling plate 7 is mounted on the piston side of the brake lining.

- Operate the foot brake lever repeatedly until the brake linings are in contact with the brake disc and there is a pressure point.

- Add brake fluid to level A.

Brake fluid DOT 4 / DOT 5.1 (☛ p. 91)

- Mount and tighten screw cap 1 with membrane 2 and the O-ring.



Info

Clean up overflowed or spilt brake fluid immediately with water.

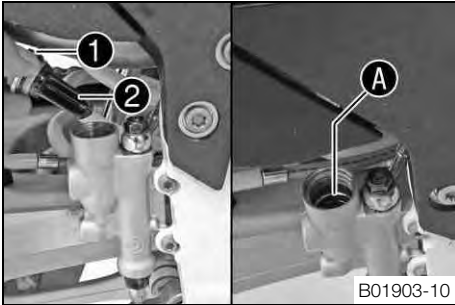

13.1 Removing the front wheel

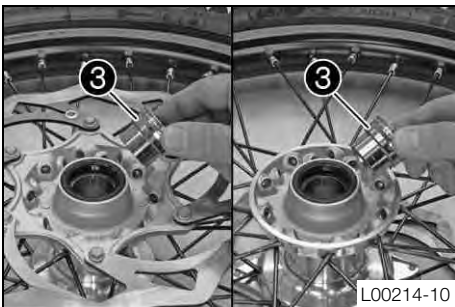
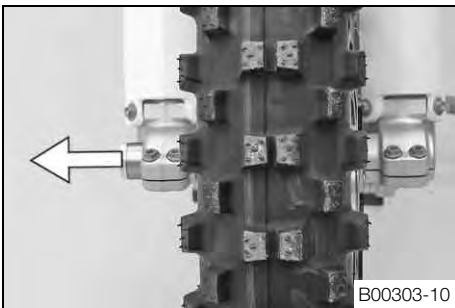
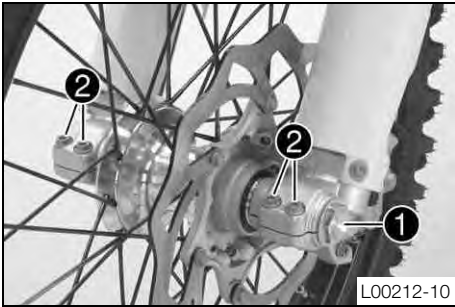

Preparatory work

- Raise the motorcycle with the lift stand. (p. 32)

Main work

- Press the brake caliper onto the brake disc by hand in order to push back the brake pistons.

i Info

Make sure when pushing back the brake pistons that you do not press the brake caliper against the spokes.

- Loosen screw **1** by several turns.
- Loosen screws **2**.
- Press on screw **1** to push the wheel spindle out of the axle clamp.
- Remove screw **1**.

- Holding the front wheel, withdraw the wheel spindle. Take the front wheel out of the fork.

i Info

Do not pull the hand brake lever when the front wheel is removed. Always lay the wheel down in such a way that the brake disc is not damaged.

- Remove spacers **3**.

13.2 Installing the front wheel



Warning

Danger of accidents Reduced braking efficiency due to oil or grease on the brake discs.

- Always keep the brake discs free of oil and grease, and clean them with brake cleaner when necessary.

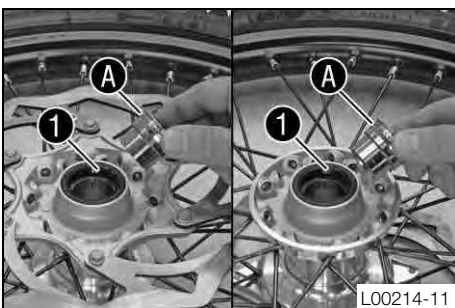

- Check the wheel bearing for damage and wear.
 - » If the wheel bearing is damaged or worn:
 - Change the wheel bearing.
- Clean and grease the shaft seal rings **1** and contact surface **A** of the spacers.
- Insert the spacers.
- Position the front wheel and insert the wheel spindle.
 - ✓ The brake linings are correctly positioned.

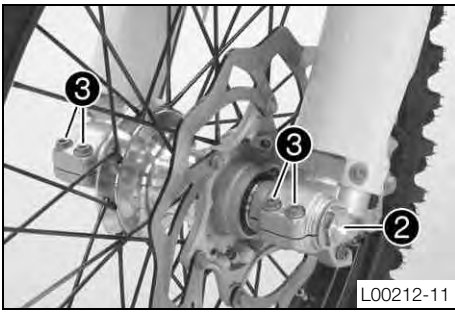

- Mount and tighten screw ②.

Guideline

Screw, front wheel spindle	M24x1.5	45 Nm (33.2 lbf ft)
----------------------------	---------	---------------------

- Activate the hand brake lever multiple times until the brake linings are in contact with the brake disc.
- Remove the motorcycle from the lift stand. (☛ p. 32)
- Pull the front brake and compress the fork powerfully a few times.
 - ✓ The fork legs straighten.
- Tighten screws ③.

Guideline

Screw, fork stub	M8	15 Nm (11.1 lbf ft)
------------------	----	---------------------

13.3 Removing the rear wheel ☞

Preparatory work

- Raise the motorcycle with the lift stand. (☛ p. 32)

Main work

- Press the brake caliper onto the brake disc by hand in order to push back the brake piston.

i Info

Make sure when pushing back the brake piston that you do not press the brake caliper against the spokes.

- Remove nut ①.
- Remove chain adjuster ②. Withdraw wheel spindle ③ only enough to allow the rear wheel to be pushed forward.
- Push the rear wheel forward as far as possible. Remove the chain from the rear sprocket.

i Info

Protect the components against damage by covering them.

- Holding the rear wheel, withdraw the wheel spindle. Take the rear wheel out of the swing arm.

i Info

Do not operate the foot brake when the rear wheel is removed. Always lay the wheel down in such a way that the brake disc is not damaged.

- Remove spacers ④.

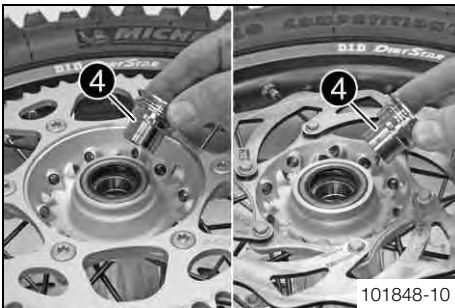
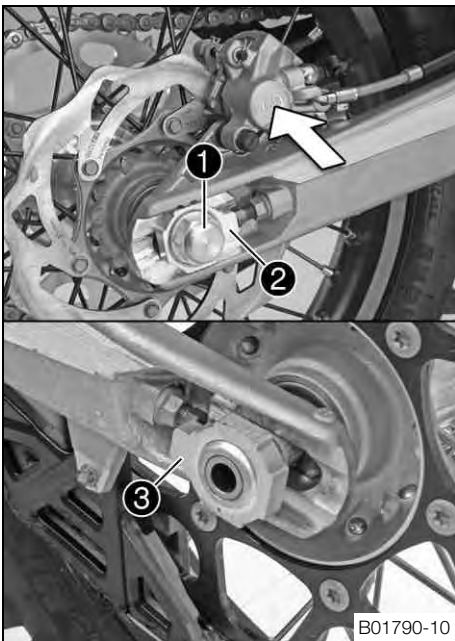

13.4 Installing the rear wheel ☞

! Warning

Danger of accidents Reduced braking efficiency due to oil or grease on the brake discs.

- Always keep the brake discs free of oil and grease, and clean them with brake cleaner when necessary.

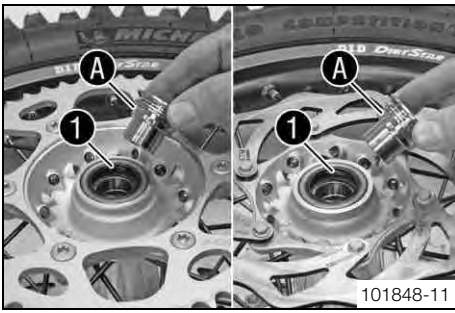

Main work

- Check the wheel bearing for damage and wear.
 - » If the wheel bearing is damaged or worn:
 - Change the wheel bearing. 🛠️
- Clean and grease the shaft seal rings **1** and contact surface **A** of the spacers.
- Insert the spacers.

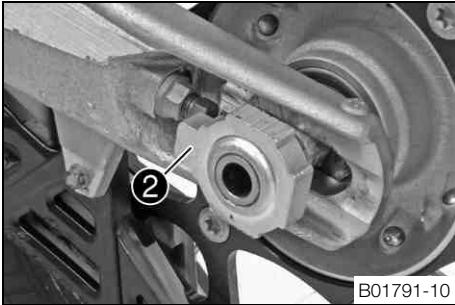

- Position the rear wheel and insert wheel spindle **2**.
 - ✓ The brake linings are correctly positioned.
- Put the chain on.

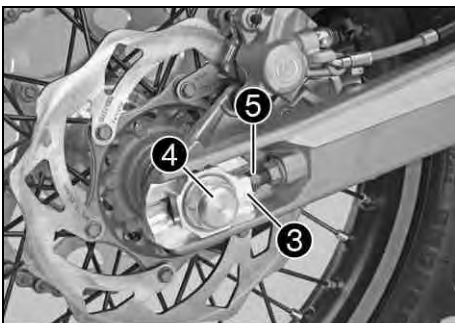

- Position chain adjuster **3**. Mount nut **4**, but do not tighten it yet.
- Make sure that chain adjusters **3** are fitted correctly on adjusting screws **5**.
- Check the chain tension. (🔧 p. 49)
- Tighten nut **4**.

Guideline

Nut, rear wheel spindle	M20x1.5	80 Nm (59 lbf ft)
-------------------------	---------	-------------------

i Info

The wide adjustment range of the chain adjusters (32 mm (1.18 in)) enables different secondary ratios with the same chain length. Chain adjusters **3** can be turned by 180°.

- Operate the foot brake lever repeatedly until the brake linings are in contact with the brake disc and there is a pressure point.

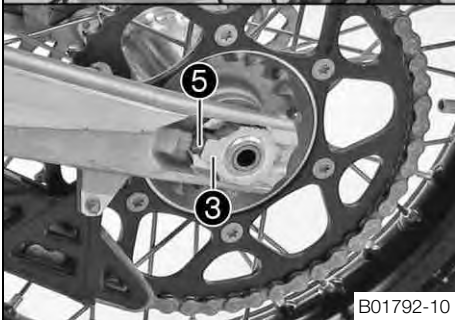

Finishing work

- Remove the motorcycle from the lift stand. (🔧 p. 32)

13.5 Checking the tire condition

i Info

Only mount tires approved and/or recommended by Husqvarna. Other tires could have a negative effect on riding behavior. The type, condition and air pressure of the tires all have an important impact on the riding behavior of the motorcycle. The tires mounted on the front and rear wheels must have a similar profile. Worn tires have a negative effect on riding behavior, especially on wet surfaces.

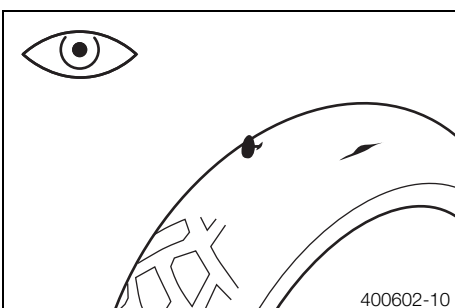

- Examine the front and rear tires for cuts, foreign bodies and other damage.
 - » If you find cuts, foreign bodies or other damage on a tire:
 - Change the tire.
- Check the depth of the tread.

i Info

Note local national regulations concerning the minimum tread depth.

Minimum tread depth	≥ 2 mm (≥ 0.08 in)
---------------------	--------------------

- » If the tread depth is less than the minimum allowable depth:
 - Change the tire.
- Check the tire age.



Info

The tire manufacture date is usually included in the tire identification number and comprises the last four digits of the **DOT** code. The first two digits indicate the week of manufacture and the last two digits the year of manufacture. Husqvarna recommends that the tires be changed after 5 years at the latest, regardless of the actual state of wear.

- » If the tire is older than five years:
 - Change the tire.

13.6 Checking the tire air pressure



Info

Low tire air pressure leads to abnormal wear and overheating of the tire. Correct tire air pressure ensures optimal riding comfort and maximum tire service life.

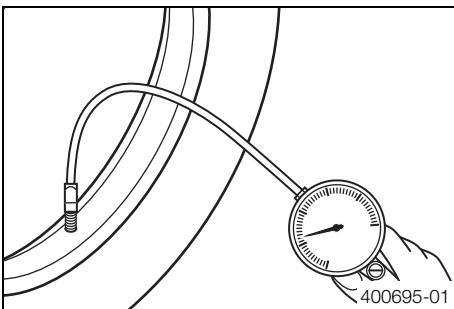

- Remove the protection cap.
- Check the tire air pressure when the tires are cold.

Tire air pressure, offroad	
Front	1.0 bar (15 psi)
Rear	1.0 bar (15 psi)

- » If the tire pressure does not meet specifications:
 - Correct the tire pressure.
- Mount the protection cap.

13.7 Checking the spoke tension



Warning

Danger of accidents Instable handling due to incorrect spoke tension.

- Ensure that the spoke tension is correct. (Your authorized Husqvarna workshop will be glad to help.)



Info

A loose spoke causes wheel imbalance and rapidly leads to more loose spokes. If the spokes are too tight, they can break due to local overload. Check the spoke tension regularly, especially on a new motorcycle.

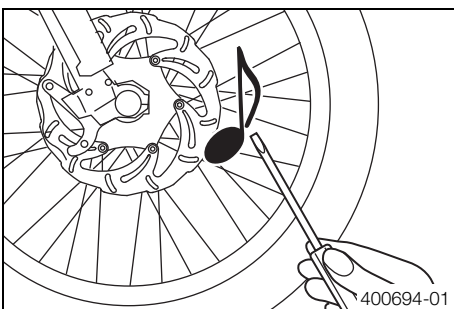

- Briefly strike each spoke with the tip of a screwdriver.



Info

The tone frequency depends on the length of the spoke and the spoke diameter. If you hear different tone frequencies from different spokes of equal length and diameter, this is an indication of different spoke tensions.

You should hear a high note.

- » If the spoke tension varies:
 - Correct the spoke tension. 🛠️
- Check the spoke torque.

Guideline

Spoke nipple, front wheel	M4.5	5... 6 Nm (3.7... 4.4 lbf ft)
Spoke nipple, rear wheel	M4.5	5... 6 Nm (3.7... 4.4 lbf ft)

Torque wrench with various accessories in set (58429094000)

14.1 Removing the battery

Warning

Risk of injury Battery acid and battery gases cause serious chemical burns.

- Keep batteries out of the reach of children.
- Wear suitable protective clothing and goggles.
- Avoid contact with battery acid and battery gases.
- Keep sparks and open flames away from the battery. Only charge in well-ventilated rooms.
- In the event of skin contact, rinse with large amounts of water. If battery acid gets in the eyes, rinse with water for at least 15 minutes and contact a physician.

Preparatory work

- Switch off all power consumers and switch off the engine.
- Remove the seat. (☛ p. 42)

Main work

- Pull back the negative terminal cover **1** and disconnect the negative cable from the battery.
- Pull back the positive terminal cover **2** and disconnect the positive cable from the battery.
- Detach rubber band **3** from the bottom.
- Lift the battery out.

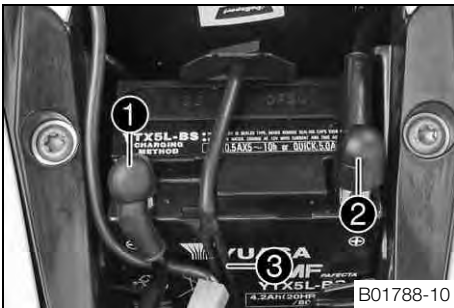

14.2 Installing the battery

Main work

- Insert the battery into the battery compartment with the terminals facing to the front.
- Battery (YTX5L-BS) (☛ p. 88)
- Reconnect rubber band **1**.

Info

Contact disk **A** must be mounted between screw **4** and cable socket **5** with the claws facing down.

- Position the positive cable and mount and tighten the screw.

Guideline

Screw, battery terminal	M5	2.5 Nm (1.84 lbf ft)
-------------------------	----	----------------------

- Slide positive terminal cover **2** over the positive terminal.
- Position the negative cable and mount and tighten the screw.

Guideline

Screw, battery terminal	M5	2.5 Nm (1.84 lbf ft)
-------------------------	----	----------------------

- Slide negative terminal cover **3** over the negative terminal.

Finishing work

- Mount the seat. (☛ p. 42)

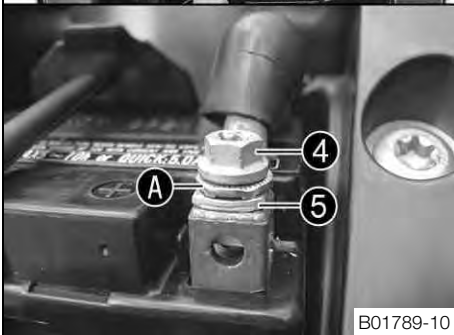
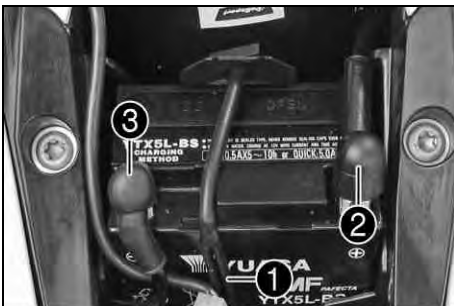

14.3 Recharging the battery ↱

- Warning**
Risk of injury Battery acid and battery gases cause serious chemical burns.
- Keep batteries out of the reach of children.
 - Wear suitable protective clothing and goggles.
 - Avoid contact with battery acid and battery gases.
 - Keep sparks and open flames away from the battery. Only charge in well-ventilated rooms.
 - In the event of skin contact, rinse with large amounts of water. If battery acid gets in the eyes, rinse with water for at least 15 minutes and contact a physician.

- Warning**
Environmental hazard Battery components and acid are harmful to the environment.
- Do not dispose of batteries with the household waste. Dispose of a defective battery in an environmentally friendly manner. Give it to your Husqvarna dealer or to a disposal center for used batteries.

- Warning**
Environmental hazard Hazardous substances cause environmental damage.
- Oil, grease, filters, fuel, cleaners, brake fluid, etc., should be disposed of as stipulated in applicable regulations.

i Info
 Even when there is no load on the battery, it still loses power steadily. The charge state and the type of charge are very important for the service life of the battery. Rapid recharging with a high charging current shortens the battery's service life. If the charging current, charging voltage and charging time are exceeded, electrolyte escapes through the safety valves. This reduces the battery capacity. If the battery is depleted from starting the vehicle repeatedly, the battery must be charged immediately. If the battery is left in a discharged state for an extended period, it will become over-discharged and sulfate, destroying the battery. The battery is maintenance-free, i.e., the acid level does not have to be checked.

- Preparatory work**
- Switch off all power consumers and switch off the engine.
 - Remove the seat. (↱ p. 42)
 - Disconnect the negative (minus) cable of the battery to avoid damage to the motorcycle's electronics.



- Main work**
- Connect the battery charger to the battery. Switch on the battery charger.

Battery charger (81229074000)

You can also use the battery charger to test rest potential and start potential of the battery, and to test the alternator. With this device, you cannot overcharge the battery.

- i Info**
 Never remove cover ①.
 Charge the battery with a maximum of 10% of the capacity specified on the battery housing ②.

- Switch off the charger after charging. Disconnect the battery.

Guideline

The charge current, charge voltage and charge time must not be exceeded.

Charge the battery regularly when the motorcycle is not in use	3 months
--	----------

- Finishing work**
- Mount the seat. (↱ p. 42)

14.4 Changing the main fuse

Warning

Fire hazard The electrical system can be overloaded if the wrong fuses are used.

- Use only fuses with the prescribed amperage. Never by-pass or repair fuses.

Info

The main fuse protects all power consumers of the vehicle. It is located in the starter relay housing under the air filter box lid.

Preparatory work

- Switch off all power consumers and switch off the engine.
- Remove the air filter box lid. (☞ p. 42)

Main work

- Take off protection caps **1**.
- Remove the faulty main fuse **2**.

Info

A defective fuse is indicated by a burned-out fuse wire **A**.
A spare fuse **3** is located in the starter relay.

- Install a new main fuse.

Fuse (58011109110) (☞ p. 88)

- Check that the electrical equipment is functioning.

Tip

Insert the spare fuse so that it is available if needed.

- Mount the protection caps.
- Mount the starter relay onto the holder and lay the cable.

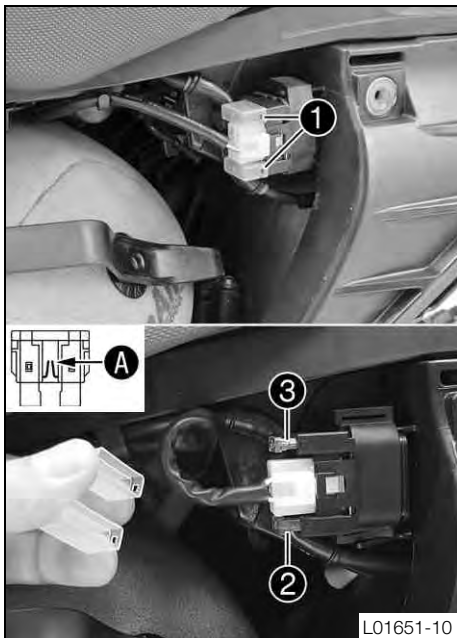

Finishing work

- Install the air filter box lid. (☞ p. 42)

15.1 Cooling system

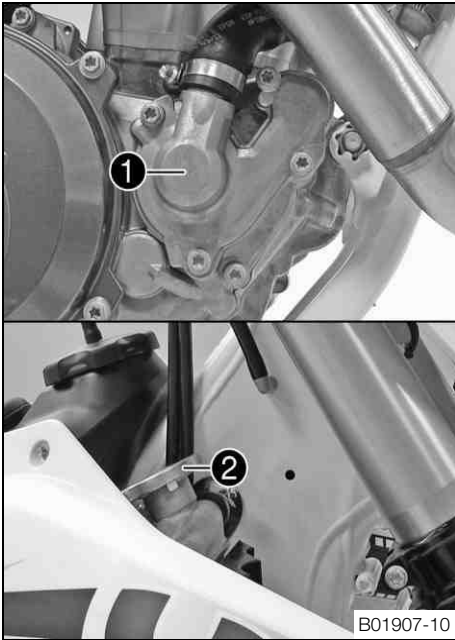

Water pump **1** in the engine circulates the coolant.

The pressure resulting from the warming of the cooling system is regulated by a valve in radiator cap **2**. This ensures that operating the vehicle at the specified coolant temperature will not result in a risk of malfunctions.

120 °C (248 °F)

Cooling is effected by the air stream.

The lower the speed, the less the cooling effect. Dirty cooling fins also reduce the cooling effect.

15.2 Checking the antifreeze and coolant level

Warning
Danger of scalding During motorcycle operation, the coolant gets very hot and is under pressure.

- Do not remove the radiator cap, radiator hoses or other cooling system components when the engine is hot. Allow the engine and cooling system to cool down. In case of scalding, rinse immediately with lukewarm water.

Warning
Danger of poisoning Coolant is poisonous and a health hazard.

- Coolant must not come into contact with the skin, eyes, or clothing. If contact occurs with the eyes, rinse with water immediately and contact a physician. Immediately clean contaminated areas on the skin with soap and water. If coolant is swallowed, contact a physician immediately. Change clothing that is contaminated with coolant. Keep coolant out of reach of children.

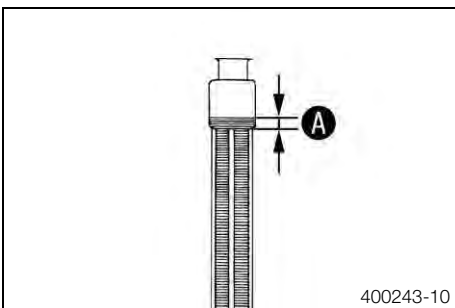

Condition

The engine is cold.

- Stand the motorcycle upright on a horizontal surface.
- Remove the radiator cap.
- Check the antifreeze of the coolant.

-25... -45 °C (-13... -49 °F)

» If the antifreeze of the coolant does not meet specifications:

- Correct the antifreeze of the coolant.

- Check the coolant level in the radiator.

Coolant level A above radiator fins.	10 mm (0.39 in)
---	-----------------

» If the coolant level does not meet specifications:

- Correct the coolant level.

Alternative 1

Coolant (☛ p. 91)

Alternative 2

Coolant (mixed ready to use) (☛ p. 91)
--

- Mount the radiator cap.

15.3 Checking the coolant level

Warning

Danger of scalding During motorcycle operation, the coolant gets very hot and is under pressure.

- Do not remove the radiator cap, radiator hoses or other cooling system components when the engine is hot. Allow the engine and cooling system to cool down. In case of scalding, rinse immediately with lukewarm water.

Warning

Danger of poisoning Coolant is poisonous and a health hazard.

- Coolant must not come into contact with the skin, eyes, or clothing. If contact occurs with the eyes, rinse with water immediately and contact a physician. Immediately clean contaminated areas on the skin with soap and water. If coolant is swallowed, contact a physician immediately. Change clothing that is contaminated with coolant. Keep coolant out of reach of children.

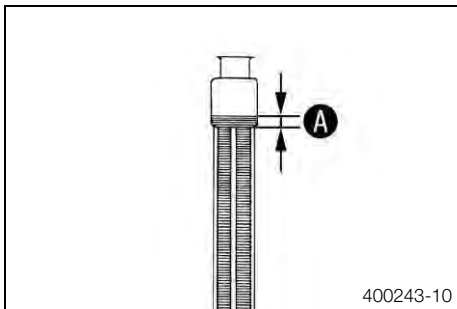

Condition

The engine is cold.

- Stand the motorcycle upright on a horizontal surface.
- Remove the radiator cap.
- Check the coolant level in the radiator.

Coolant level A above radiator fins.	10 mm (0.39 in)
---	-----------------

- » If the coolant level does not meet specifications:
 - Correct the coolant level.

Alternative 1

Coolant (☛ p. 91)

Alternative 2

Coolant (mixed ready to use) (☛ p. 91)
--

- Mount the radiator cap.

15.4 Draining the coolant ☞

Warning

Danger of scalding During motorcycle operation, the coolant gets very hot and is under pressure.

- Do not remove the radiator cap, radiator hoses or other cooling system components when the engine is hot. Allow the engine and cooling system to cool down. In case of scalding, rinse immediately with lukewarm water.

Warning

Danger of poisoning Coolant is poisonous and a health hazard.

- Coolant must not come into contact with the skin, eyes, or clothing. If contact occurs with the eyes, rinse with water immediately and contact a physician. Immediately clean contaminated areas on the skin with soap and water. If coolant is swallowed, contact a physician immediately. Change clothing that is contaminated with coolant. Keep coolant out of reach of children.

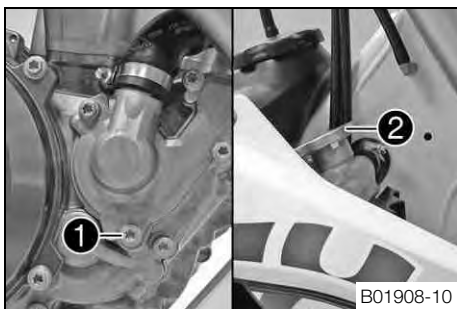

Condition

The engine is cold.

- Position the motorcycle upright.
- Place a suitable container under the water pump cover.
- Remove screw **1**. Take off radiator cap **2**.
- Completely drain the coolant.
- Mount and tighten screw **1** with a new seal ring.

Guideline

Screw, water pump cover	M6	10 Nm (7.4 lbf ft)
-------------------------	----	--------------------

15.5 Refilling coolant

Warning

Danger of poisoning Coolant is poisonous and a health hazard.

- Coolant must not come into contact with the skin, eyes, or clothing. If contact occurs with the eyes, rinse with water immediately and contact a physician. Immediately clean contaminated areas on the skin with soap and water. If coolant is swallowed, contact a physician immediately. Change clothing that is contaminated with coolant. Keep coolant out of reach of children.

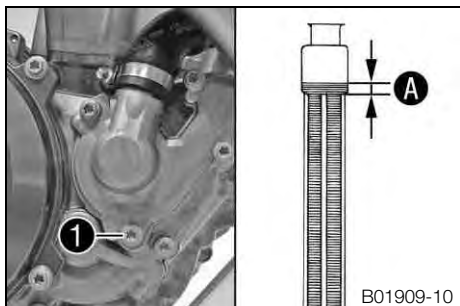

- Make sure that screw 1 is tightened.
- Position the motorcycle upright.
- Pour coolant in up to measurement A above the radiator fins.

Guideline

Dimension A over the radiator fins	10 mm (0.39 in)	
Coolant	0.95 l (1 qt.)	Coolant (☛ p. 91)
		Coolant (mixed ready to use) (☛ p. 91)

- Mount the radiator cap.
- Take a short test ride.
- Check the coolant level. (☛ p. 72)

16.1 Checking the play in the throttle cable

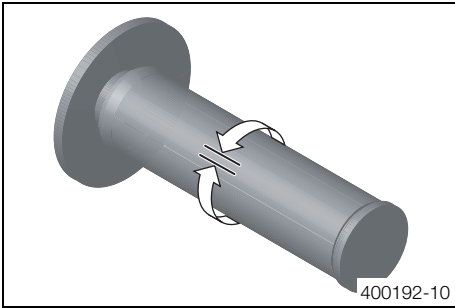

- Check the throttle grip for smooth operation.
- Move the handlebar to the straight-ahead position. Move the throttle grip backwards and forwards to ascertain the play in the throttle cable.

Throttle cable play	3... 5 mm (0.12... 0.2 in)
---------------------	----------------------------

- » If the throttle cable play does not meet specifications:
 - Adjust the play in the throttle cable. 🛠️ (☞ p. 74)



Danger

Danger of poisoning Exhaust gases are toxic and inhaling them may result in unconsciousness and/or death.

- When running the engine, always make sure there is sufficient ventilation, and do not start or run the engine in an enclosed space without an effective exhaust extraction system.

- Start the engine and let it run idle. Move the handlebar to and fro over the entire steering range.

The idle speed must not change.

- » If the idle speed changes:
 - Adjust the play in the throttle cable. 🛠️ (☞ p. 74)

16.2 Adjusting the play in the throttle cable 🛠️

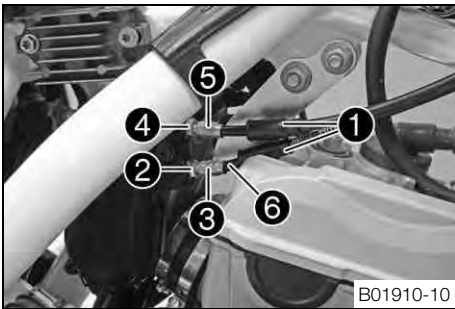

Preparatory work

- Remove the seat. (☞ p. 42)
- Remove the fuel tank. 🛠️ (☞ p. 46)
- Check the throttle cable routing. (☞ p. 52)

Main work

- Move the handlebar to the straight-ahead position.
- Push back sleeves ①.
- Loosen nut ②. Turn adjusting screw ③ in as far as possible.
- Loosen nut ④. Turn adjusting screw ⑤ so that there is play in the throttle cable at the throttle grip.

Guideline

Throttle cable play	3... 5 mm (0.12... 0.2 in)
---------------------	----------------------------

- Tighten nut ④.
- Press and hold the throttle grip in the closed setting. Turn adjusting screw ③ out until there is no play in the throttle cable ⑥.
- Tighten nut ②.
- Push sleeves ① on. Check the throttle grip for smooth operation.

Finishing work

- Install the fuel tank. 🛠️ (☞ p. 47)
- Mount the seat. (☞ p. 42)
- Check the play in the throttle cable. (☞ p. 74)

16.3 Adjusting the idle speed 🛠️

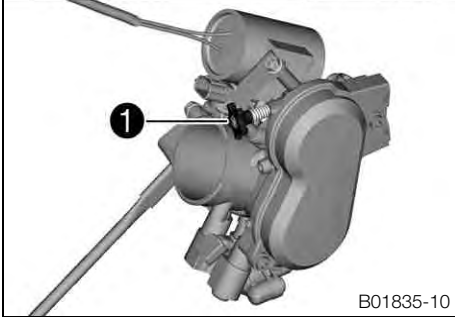

- Run the engine until warm.
- Set the desired idle speed by turning the idle speed adjusting screw ①.

Guideline

Idle speed	2,250... 2,350 rpm
------------	--------------------

i Info

Turn counterclockwise to decrease the idle speed.
Turn clockwise to increase the idle speed.

16.4 Checking the basic position of the shift lever

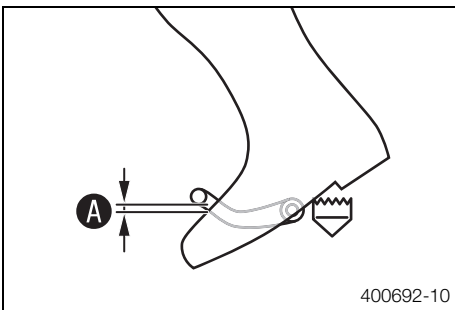

- Sit on the vehicle in the riding position and determine the distance A between the upper edge of your boot and the shift lever.

Distance between shift lever and upper edge of boot	10... 20 mm (0.39... 0.79 in)
---	-------------------------------

- » If the distance does not meet specifications:
 - Adjust the basic position of the shift lever. 🛠️ (p. 75)

16.5 Adjusting the basic position of the shift lever 🛠️

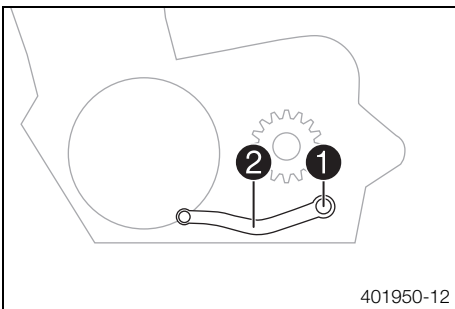

- Remove screw ① and take off shift lever ②.

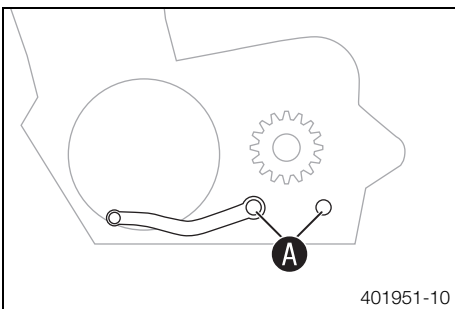

- Clean gear teeth A of the shift lever and shift shaft.
- Mount the shift lever on the shift shaft in the required position and engage the gearing.

i Info

The range of adjustment is limited.
The shift lever must not come into contact with any other vehicle components during the shift procedure.

- Mount and tighten the screw.

Guideline

Screw, shift lever	M6	14 Nm (10.3 lbf ft)	Loctite® 243™
--------------------	----	------------------------	----------------------

17.1 Changing the fuel screen



Danger

Fire hazard Fuel is highly flammable.

- Never refuel the vehicle near open flames or burning cigarettes, and always switch off the engine first. Be careful that no fuel is spilt, especially on hot vehicle components. Clean up spilt fuel immediately.
- The fuel in the fuel tank expands when warm and may emerge if overfilled. Follow the instructions on refueling.



Warning

Danger of poisoning Fuel is poisonous and a health hazard.

- Fuel must not come into contact with the skin, eyes, or clothing. Do not breathe in the fuel vapors. If contact occurs with the eyes, rinse with water immediately and contact a physician. Immediately clean contaminated areas on the skin with soap and water. If fuel is swallowed, contact a physician immediately. Change clothing that is contaminated with fuel.



Warning

Environmental hazard Improper handling of fuel is a danger to the environment.

- Do not allow fuel to get into the ground water, the ground, or the sewage system.



- Clean the plug-in connection **1** of the fuel line thoroughly with compressed air.



Info

Under no circumstances should dirt enter into the fuel line. Dirt clogs the injection valve.

- Disconnect the plug-in connection of the fuel line.
- Pull fuel screen **2** out of the connecting piece.
- Insert the new fuel screen all the way into the connecting piece.
- Lubricate the O-ring and connect the plug-in connection of the fuel line.



Danger

Danger of poisoning Exhaust gases are toxic and inhaling them may result in unconsciousness and/or death.

- When running the engine, always make sure there is sufficient ventilation, and do not start or run the engine in an enclosed space without an effective exhaust extraction system.
- Start the engine and check the response.

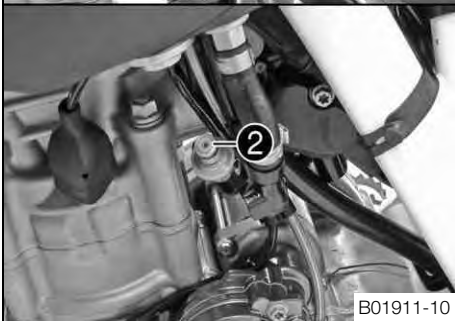

B01911-10

17.2 Checking the engine oil level



Info

The engine oil level can be checked when the engine is cold or warm.

Preparatory work

- Stand the motorcycle upright on a horizontal surface.

Condition

The engine is cold.

- Check the engine oil level.

The engine oil level is up to the middle **A** of the level viewer.

» If the engine oil is not up to the middle of the level viewer:

- Add engine oil. ( p. 79)

Condition

The engine is at operating temperature.

- Check the engine oil level.

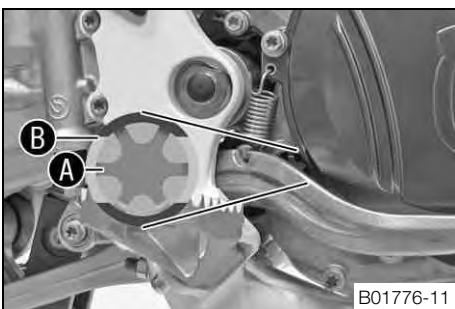

B01776-11



Info

After switching off the engine, wait one minute before checking the level.

The engine oil is at a level between the middle **A** and upper edge **B** of the level viewer.

- » If the engine oil is not up to the middle **A** of the level viewer:
 - Add engine oil. (☛ p. 79)

17.3 Changing the engine oil and oil filter, cleaning the oil screen ☛

Warning

Danger of scalding Engine oil and gear oil get very hot when the motorcycle is ridden.

- Wear appropriate protective clothing and safety gloves. In case of burns, rinse immediately with lukewarm water.

Warning

Environmental hazard Hazardous substances cause environmental damage.

- Oil, grease, filters, fuel, cleaners, brake fluid, etc., should be disposed of as stipulated in applicable regulations.

Info

Drain the engine oil only when the engine is warm.

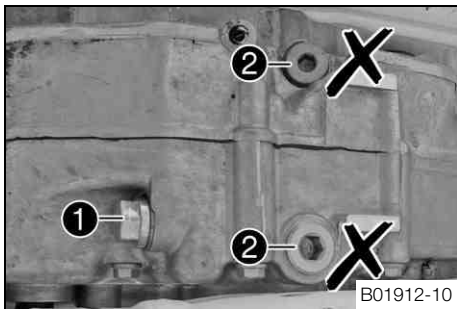

B01912-10

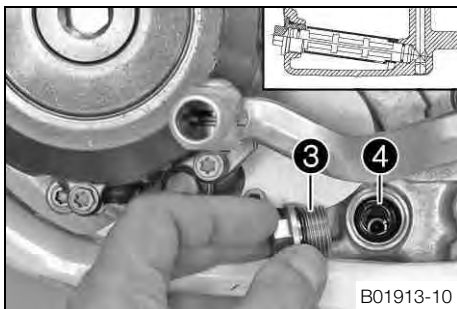

B01913-10

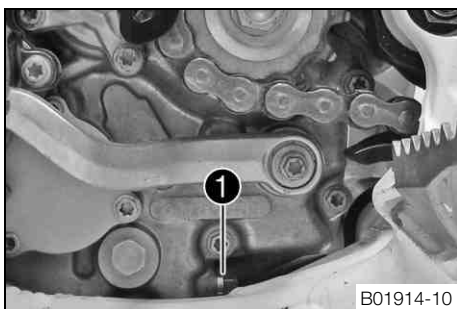

B01914-10

Preparatory work

- Park the motorcycle on a level surface.

Main work

- Place a suitable container under the engine.
- Remove oil drain plug **1** with the magnet and seal ring.

Info

Do not remove screws **2** on both sides.

- Remove screw plug **3** with oil screen **4**.
- Completely drain the engine oil.
- Thoroughly clean the parts and sealing surfaces.
- Push the oil screen with O-rings onto a pin wrench.
- Insert the pin wrench through the drill hole of the screw plug and into the engine case on the opposite side.
- Mount and tighten screw plug **3** with the O-ring.

Guideline

Screw plug, oil screen	M20x1.5	15 Nm (11.1 lbf ft)
------------------------	---------	---------------------

- Mount and tighten the oil drain plug **1** with the magnet and a new seal ring.

Guideline

Oil drain plug with magnet	M12x1.5	20 Nm (14.8 lbf ft)
----------------------------	---------	---------------------

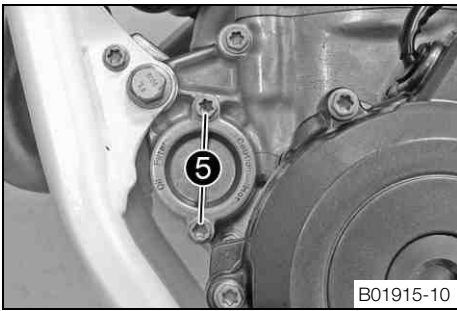

- Remove screws **5**. Remove the oil filter cover with the O-ring.

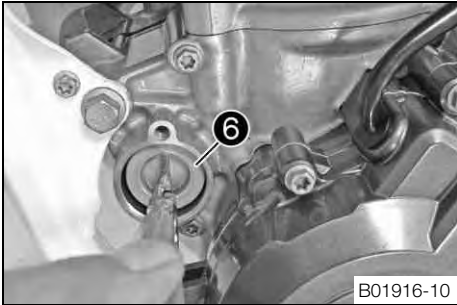

- Pull oil filter **6** out of the oil filter housing.

Circlip pliers reverse (51012011000)

- Completely drain the engine oil.
- Thoroughly clean the parts and sealing surfaces.

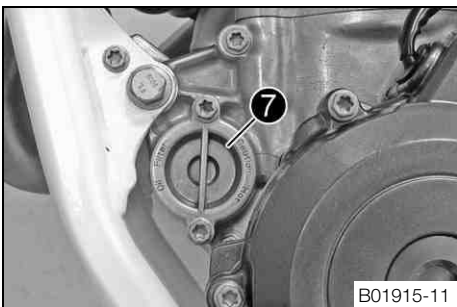

- Lay the motorcycle on its side and fill the oil filter housing to about 1/3 full with engine oil.
- Fill the oil filter with engine oil and place it in the oil filter housing.
- Oil the O-ring of the oil filter cover and mount it with the oil filter cover **7**.
- Mount and tighten the screws.

Guideline

Screw, oil filter cover	M6	10 Nm (7.4 lbf ft)
-------------------------	----	--------------------

- Stand the motorcycle upright.

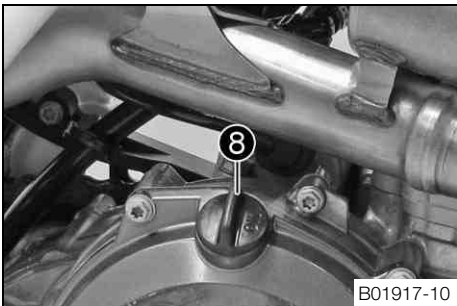

- Remove the oil filler plug **8** with the O-ring from the clutch cover and fill up with engine oil.

Engine oil	1.10 l (1.16 qt.)	Engine oil (SAE 10W/50) (☛ p. 91)	
		Alternative engine oil for harsh operating conditions and increased performance	Engine oil (SAE 10W/60) (☛ p. 91)



Info

Too little engine oil or poor-quality engine oil results in premature wear to the engine.

- Install and tighten the oil filler plug with O-ring.



Danger

Danger of poisoning Exhaust gases are toxic and inhaling them may result in unconsciousness and/or death.

- When running the engine, always make sure there is sufficient ventilation, and do not start or run the engine in an enclosed space without an effective exhaust extraction system.

- Start the engine and check that it is oil-tight.

Finishing work

- Check the engine oil level. (☛ p. 76)

17.4 Adding engine oil



Info

Too little engine oil or poor-quality engine oil results in premature wear to the engine.

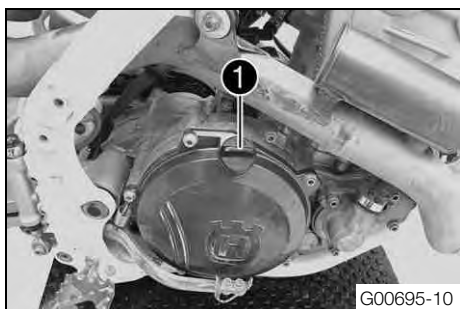

- Remove the oil filler plug ❶ with the O-ring from the clutch cover.
- Add the same engine oil that was used when the motor was changed.

Engine oil (SAE 10W/50) (☞ p. 91)

Alternative 1

Engine oil (SAE 10W/60) (☞ p. 91)



Info

For optimal performance of the engine oil, do not mix different types of engine oil.

If appropriate, change the engine oil.

- Install and tighten the oil filler plug with O-ring.



Danger

Danger of poisoning Exhaust gases are toxic and inhaling them may result in unconsciousness and/or death.

- When running the engine, always make sure there is sufficient ventilation, and do not start or run the engine in an enclosed space without an effective exhaust extraction system.

- Start the engine and check that it is oil-tight.

18.1 Cleaning the motorcycle

Note

Material damage Damage and destruction of components by high-pressure cleaning equipment.

- When cleaning the vehicle with a pressure cleaner, do not point the water jet directly onto electrical components, connectors, cables, bearings, etc. Maintain a minimum distance of 60 cm between the nozzle of the pressure cleaner and the component. Excessive pressure can cause malfunctions or destroy these parts.

Warning

Environmental hazard Hazardous substances cause environmental damage.

- Oil, grease, filters, fuel, cleaners, brake fluid, etc., should be disposed of as stipulated in applicable regulations.

Info

If you clean the motorcycle regularly, its value and appearance will be maintained over a long period. Avoid direct sunshine on the motorcycle during cleaning.

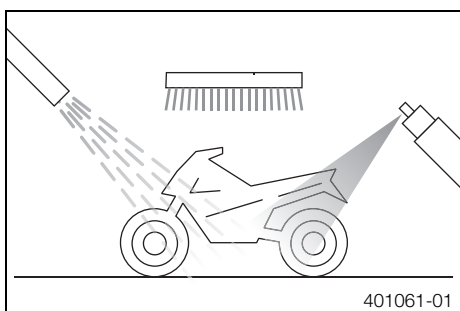

- Close off the exhaust system to keep water from entering.
- First remove coarse dirt particles with a gentle spray of water.
- Spray very dirty areas with a normal motorcycle cleaner and then clean with a paint-brush.

Info

Use warm water containing normal motorcycle cleaner and a soft sponge. Never apply motorcycle cleaner to a dry vehicle; always rinse the vehicle with water first.

- After rinsing the motorcycle with a gentle spray of water, allow it to dry thoroughly.
- Remove the closure of the exhaust system.



Warning

Danger of accidents Reduced braking efficiency due to a wet or dirty brake system.

- Clean or dry a dirty or wet brake system by riding and braking gently.

- After cleaning, ride a short distance until the engine reaches operating temperature.

Info

The heat produced causes water at inaccessible locations in the engine and on the brake system to evaporate.

- Push back the protection caps of the handlebar controls to allow any water that has penetrated to evaporate.
- After the motorcycle has cooled off, lubricate all moving parts and bearings.
- Clean the chain. (☛ p. 48)
- Treat bare metal parts (except for brake discs and the exhaust system) with a corrosion inhibitor.
- Treat all plastic parts and powder-coated parts with a mild cleaning and care agent.

19.1 Storage

Warning
Danger of poisoning Fuel is poisonous and a health hazard.

- Fuel must not come into contact with the skin, eyes, or clothing. Do not breathe in the fuel vapors. If contact occurs with the eyes, rinse with water immediately and contact a physician. Immediately clean contaminated areas on the skin with soap and water. If fuel is swallowed, contact a physician immediately. Change clothing that is contaminated with fuel. Store fuel properly in a suitable canister and keep away from children.

Info
 If you want to garage the motorcycle for a longer period, take the following steps. Before storing the motorcycle, check all parts for function and wear. If service, repairs, or replacements are necessary, you should do this during the storage period (less workshop overload). In this way, you can avoid long workshop waiting times at the start of the new season.

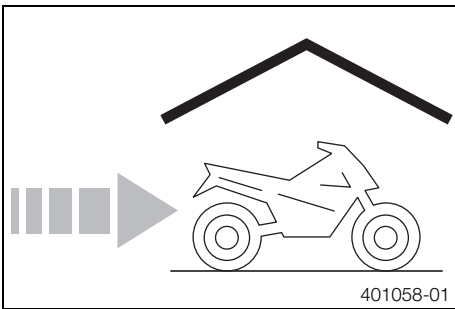

- When refueling for the last time before taking the motorcycle out of service, add fuel additive.
- Refuel. (☛ p. 22)
- Clean the motorcycle. (☛ p. 80)
- Change the engine oil and oil filter, clean the oil screen. 🛠️ (☛ p. 77)
- Check the antifreeze and coolant level. (☛ p. 71)
- Drain the fuel from the fuel tanks into a suitable container.
- Check the tire air pressure. (☛ p. 67)
- Remove the battery. 🛠️ (☛ p. 68)
- Recharge the battery. 🛠️ (☛ p. 69)

Guideline

Storage temperature of battery without direct sunlight	0... 35 °C (32... 95 °F)
--	--------------------------

- Store the vehicle in a dry location that is not subject to large fluctuations in temperature.

Info
 Husqvarna recommends raising the motorcycle.

- Raise the motorcycle with the lift stand. (☛ p. 32)
- Cover the vehicle with a tarp or a cover that is permeable to air.

Info
 Do not use non-porous materials since they prevent humidity from escaping, thus causing corrosion.
 Avoid running the engine for a short time only. Since the engine cannot warm up properly, the water vapor produced during combustion condenses and causes valves and exhaust system to rust.



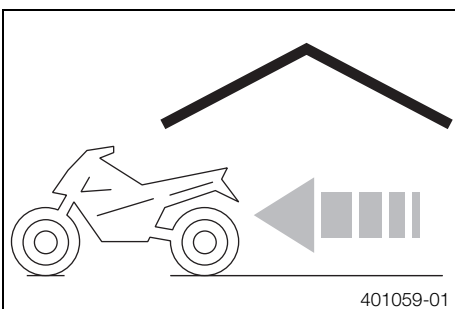





19.2 Putting into operation after storage



- Remove the motorcycle from the lift stand. (☛ p. 32)
- Install the battery. 🛠️ (☛ p. 68)
- Perform checks and maintenance steps before putting into operation. (☛ p. 20)
- Take a test ride.

Faults	Possible cause	Action
The engine cannot be cranked (electric starter)	Operating error	– Carry out the start procedure. (☞ p. 20)
	Battery discharged	– Recharge the battery. 🛠️ (☞ p. 69) – Check the charging voltage. 🛠️ – Check the open-circuit current. 🛠️ – Check the stator winding of the alternator. 🛠️
	Main fuse burned out	– Change the main fuse. (☞ p. 70)
	Faulty starter relay	– Check the starter relay. 🛠️
	Faulty starter motor	– Check the starter motor. 🛠️
Engine turns but does not start	Coupling of fuel hose connection not joined together	– Join the fuel hose connection.
	Fuel screen in the fuel hose connection is clogged	– Change the fuel screen. 🛠️ (☞ p. 76)
	Idle speed is not set correctly	– Adjust the idle speed. 🛠️ (☞ p. 75)
	Spark plug oily or wet	– Clean and dry the spark plug, or change it if necessary.
	Electrode distance (plug gap) of spark plug too wide	– Adjust the plug gap. Guideline Spark plug electrode gap 0.8 mm (0.031 in)
	Short circuit cable in wiring harness frayed, kill switch defective	– Check the wiring harness. (visual check) – Check the electrical system.
	Defect in fuel injection system	– Read out the fault memory using the Husqvarna diagnostics tool. 🛠️
Engine does not speed up	Defect in fuel injection system – Read out the fault memory using the Husqvarna diagnostics tool. 🛠️	
Engine has too little power	Air filter is very dirty	– Clean the air filter and air filter box. 🛠️ (☞ p. 43)
	Fuel filter is very dirty	– Change the fuel filter. 🛠️
	Defect in fuel injection system	– Read out the fault memory using the Husqvarna diagnostics tool. 🛠️
	Exhaust system leaky, deformed or too little glass fiber yarn filling in main silencer	– Check exhaust system for damage. – Change the glass fiber yarn filling of the main silencer. 🛠️ (☞ p. 45)
	Valve clearance too little	– Adjust the valve clearance. 🛠️
Engine dies during the trip	Lack of fuel – Refuel. (☞ p. 22)	
Engine overheats	Too little coolant in cooling system	– Check the cooling system for leakage. – Check the coolant level. (☞ p. 72)
	Too little air stream	– Switch off the engine when standing.
	Radiator fins very dirty	– Clean the radiator fins.
	Foam formation in cooling system	– Drain the coolant. 🛠️ (☞ p. 72) – Refill the coolant. 🛠️ (☞ p. 73)
	Bent radiator hose	– Change the radiator hose. 🛠️
FI warning lamp (MIL) lights up/flashes	Defect in fuel injection system – Stop the motorcycle and identify the faulty part using the blink code. – Check the cabling for damage and the electrical plug-in connections for corrosion and damage. – Read out the fault memory using the Husqvarna diagnostics tool. 🛠️	
High oil consumption	Engine vent hose bent	– Route the vent hose without bends or change it if necessary.
	Engine oil level too high	– Check the engine oil level. (☞ p. 76)
	Engine oil too thin (low viscosity)	– Change the engine oil and oil filter, clean the oil screen. 🛠️ (☞ p. 77)
	Piston and cylinder worn	– Piston/cylinder - determine the mounting clearance.

Faults	Possible cause	Action
Battery discharged	Battery is not charging	– Check the charging voltage. 🔧 – Check the stator winding of the alternator. 🔧
	Unwanted power consumer	– Check the open-circuit current. 🔧

Blink code FI warning lamp (MIL)	 02 FI warning lamp (MIL) flashes 2x short
Error level condition	Crankshaft position sensor - circuit fault
Blink code FI warning lamp (MIL)	 06 FI warning lamp (MIL) flashes 6x short
Error level condition	Throttle position sensor circuit A - input signal too low Throttle position sensor circuit A - input signal too high
Blink code FI warning lamp (MIL)	 09 FI warning lamp (MIL) flashes 9x short
Error level condition	Manifold absolute pressure sensor cylinder 1 - input signal too low Manifold absolute pressure sensor cylinder 1 - input signal too high
Blink code FI warning lamp (MIL)	 12 FI warning lamp (MIL) flashes 1x long, 2x short
Error level condition	Engine coolant temperature sensor - input signal too low Engine coolant temperature sensor - input signal too high
Blink code FI warning lamp (MIL)	 13 FI warning lamp (MIL) flashes 1x long, 3x short
Error level condition	Intake air temperature sensor - input signal too low Intake air temperature sensor - input signal too high
Blink code FI warning lamp (MIL)	 15 FI warning lamp (MIL) flashes 1x long, 5x short
Error level condition	Rollover sensor (A/D type) - input signal too low Rollover sensor (A/D type) - input signal too high
Blink code FI warning lamp (MIL)	 33 FI warning lamp (MIL) flashes 3x long, 3x short
Error level condition	Injector cylinder 1 - circuit fault
Blink code FI warning lamp (MIL)	 37 FI warning lamp (MIL) flashes 3x long, 7x short
Error level condition	Ignition coil 1, cylinder 1 - circuit fault
Blink code FI warning lamp (MIL)	 41 FI warning lamp (MIL) flashes 4x long, 1x short
Error level condition	Fuel pump control - short circuit to ground or open circuit Fuel pump control - input signal too low

22.1 Engine

Design	1-cylinder 4-stroke engine, water-cooled
Displacement	249.91 cm ³ (15.2505 cu in)
Stroke	52.3 mm (2.059 in)
Bore	78 mm (3.07 in)
Compression ratio	13.9:1
Idle speed	2,250... 2,350 rpm
Control	DOHC, four valves controlled via cam lever, drive via timing chain
Valve diameter, intake	32.5 mm (1.28 in)
Valve diameter, exhaust	26.5 mm (1.043 in)
Valve clearance	
Intake at: 20 °C (68 °F)	0.10... 0.15 mm (0.0039... 0.0059 in)
Exhaust at: 20 °C (68 °F)	0.13... 0.18 mm (0.0051... 0.0071 in)
Crankshaft bearing	2 cylinder bearings
Conrod bearing	Slide bearing
Piston pin bearing	Bearing bush
Pistons	Forged light alloy
Piston rings	1 compression ring, 1 oil scraper ring
Engine lubrication	Pressure circulation lubrication with two Eaton pumps
Primary transmission	24:73
Clutch	Multidisc clutch in oil bath/hydraulically activated
Gearbox	5-gear, claw shifted
Transmission ratio	
1st gear	13:32
2nd gear	16:32
3rd gear	17:28
4th gear	19:26
5th gear	21:25
Alternator	12 V, 66 W
Ignition	Contactless controlled fully electronic ignition with digital ignition adjustment
Spark plug	NGK LMAR9AI-8
Spark plug electrode gap	0.8 mm (0.031 in)
Cooling	Water cooling, permanent circulation of coolant by water pump
Starting aid	Electric starter

22.2 Engine tightening torques

Nozzle, crank chamber ventilation	M4	2 Nm (1.5 lbf ft)	Loctite® 243™
Oil nozzle for alternator cooling	M4	2 Nm (1.5 lbf ft)	Loctite® 243™
Oil nozzle for balancer shaft lubrication	M4	2 Nm (1.5 lbf ft)	Loctite® 243™
Oil nozzle for conrod bearing lubrication	M4	2 Nm (1.5 lbf ft)	Loctite® 243™
Screw, oil nozzle for piston cooling	M4	2 Nm (1.5 lbf ft)	Loctite® 243™
Screw, stator	M4	4 Nm (3 lbf ft)	Loctite® 648™
Locking screw for bearing	M5	6 Nm (4.4 lbf ft)	Loctite® 243™
Oil nozzle for cam lever lubrication	M5	3 Nm (2.2 lbf ft)	Loctite® 243™
Oil nozzle for clutch lubrication	M5	6 Nm (4.4 lbf ft)	Loctite® 243™
Oil nozzle, piston cooling	M5	2 Nm (1.5 lbf ft)	Loctite® 243™
Screw cap, oil channel in alternator cover	M5	3 Nm (2.2 lbf ft)	Loctite® 243™
Screw, crankshaft position sensor	M5	6 Nm (4.4 lbf ft)	Loctite® 243™
Screw, locking lever	M5	6 Nm (4.4 lbf ft)	Loctite® 243™

Screw, oil pump cover	M5	6 Nm (4.4 lbf ft)	Loctite® 243™
Nut, cylinder head	M6	10 Nm (7.4 lbf ft)	Lubricated with engine oil
Nut, water-pump wheel	M6	6 Nm (4.4 lbf ft)	Loctite® 243™
Screw, alternator cover	M6	10 Nm (7.4 lbf ft)	–
Screw, clutch cover	M6	10 Nm (7.4 lbf ft)	–
Screw, clutch slave cylinder	M6	10 Nm (7.4 lbf ft)	–
Screw, clutch spring	M6	10 Nm (7.4 lbf ft)	–
Screw, cover of torque limiter	M6	10 Nm (7.4 lbf ft)	–
Screw, engine case	M6	10 Nm (7.4 lbf ft)	–
Screw, exhaust flange	M6	10 Nm (7.4 lbf ft)	Loctite® 243™
Screw, oil filter cover	M6	10 Nm (7.4 lbf ft)	–
Screw, shift drum locating	M6	10 Nm (7.4 lbf ft)	Loctite® 243™
Screw, shift lever	M6	14 Nm (10.3 lbf ft)	Loctite® 243™
Screw, starter motor	M6	10 Nm (7.4 lbf ft)	–
Screw, timing chain guide rail	M6	10 Nm (7.4 lbf ft)	Loctite® 243™
Screw, timing chain securing guide	M6	10 Nm (7.4 lbf ft)	Loctite® 243™
Screw, valve cover	M6	8 Nm (5.9 lbf ft)	–
Screw, water pump cover	M6	10 Nm (7.4 lbf ft)	–
Stud, cylinder head	M6	10 Nm (7.4 lbf ft)	–
Screw, autodecompression	M7x1	15 Nm (11.1 lbf ft)	Loctite® 243™
Screw, camshaft bearing bridge	M7x1	14 Nm (10.3 lbf ft)	Lubricated with engine oil
Screw plug, crankshaft location	M8	10 Nm (7.4 lbf ft)	–
Screw, timing chain tensioning rail	M8	15 Nm (11.1 lbf ft)	Loctite® 243™
Screw, engine sprocket	M10	60 Nm (44.3 lbf ft)	Loctite® 2701™
Plug, oil channel	M10x1	15 Nm (11.1 lbf ft)	Loctite® 243™
Rotor screw	M10x1	70 Nm (51.6 lbf ft)	Thread, oiled with engine oil/cone degreased
Screw plug, cam lever axis	M10x1	10 Nm (7.4 lbf ft)	–
Screw, unlocking of timing chain tensioner	M10x1	10 Nm (7.4 lbf ft)	–
Spark plug	M10x1	10... 12 Nm (7.4... 8.9 lbf ft)	–
Nut, cylinder head	M10x1.25	Tightening sequence: Tighten diagonally. 1st tightening stage 10 Nm (7.4 lbf ft) 2nd tightening stage 30 Nm (22.1 lbf ft) 3rd tightening stage 50 Nm (36.9 lbf ft)	Thread, oiled with engine oil/cone greased
Stud, cylinder head	M10x1.25	20 Nm (14.8 lbf ft)	Loctite® 243™
Engine coolant temperature sensor	M12x1.5	12 Nm (8.9 lbf ft)	–
Oil drain plug with magnet	M12x1.5	20 Nm (14.8 lbf ft)	–
Plug, oil pressure regulator valve	M12x1.5	20 Nm (14.8 lbf ft)	–
Oil drain plug	M14x1.5	15 Nm (11.1 lbf ft)	–
Nut, inner clutch hub	M18x1.5	100 Nm (73.8 lbf ft)	Loctite® 243™
Nut, primary gear	M18LHx1.5	100 Nm (73.8 lbf ft)	Loctite® 243™
Screw plug, oil screen	M20x1.5	15 Nm (11.1 lbf ft)	–
Plug, timing chain tensioner	M24x1.5	25 Nm (18.4 lbf ft)	–
Screw, alternator cover	M24x1.5	18 Nm (13.3 lbf ft)	–

22.3 Capacities

22.3.1 Engine oil

Engine oil	1.10 l (1.16 qt.)	Engine oil (SAE 10W/50) (☛ p. 91)
		Alternative engine oil for harsh operating conditions and increased performance

Engine oil (SAE 10W/60) (☛ p. 91)

22.3.2 Coolant

Coolant	0.95 l (1 qt.)	Coolant (☛ p. 91)
		Coolant (mixed ready to use) (☛ p. 91)

22.3.3 Fuel

Total fuel tank capacity, approx.	7.5 l (1.98 US gal)	Super unleaded (ROZ 95/RON 95/PON 91) (☛ p. 92)
-----------------------------------	---------------------	---

22.4 Chassis

Frame	Central tube frame made of chrome molybdenum steel tubing	
Fork	WP Suspension Up Side Down 4860 MXMA CC	
Suspension travel		
Front	300 mm (11.81 in)	
Suspension travel		
Rear	317 mm (12.48 in)	
Fork offset	22 mm (0.87 in)	
Shock absorber	WP Suspension 5018 BAVP DCC	
Brake system	Disc brakes, brake calipers on floating bearings	
Brake discs - diameter		
Front	260 mm (10.24 in)	
Rear	220 mm (8.66 in)	
Brake discs - wear limit		
Front	2.5 mm (0.098 in)	
Rear	3.5 mm (0.138 in)	
Tire air pressure, offroad		
Front	1.0 bar (15 psi)	
Rear	1.0 bar (15 psi)	
Secondary ratio	13:50	
Chain	5/8 x 1/4"	
Available rear sprockets	48, 50, 52	
Steering head angle	63.5°	
Wheelbase	1,495±10 mm (58.86±0.39 in)	
Seat height, unloaded	992 mm (39.06 in)	
Ground clearance, unloaded	375 mm (14.76 in)	
Weight without fuel, approx.	104.1 kg (229.5 lb.)	
Maximum permissible front axle load	145 kg (320 lb.)	
Maximum permissible rear axle load	190 kg (419 lb.)	
Maximum permissible overall weight	335 kg (739 lb.)	

22.5 Electrical system

Battery	YTX5L-BS	Battery voltage: 12 V Nominal capacity: 4 Ah Maintenance-free
Fuse	58011109110	10 A

FI warning lamp	LED
-----------------	-----

22.6 Tires

Front tires	Rear tires
80/100 - 21 51M TT Dunlop GEOMAX MX51FA	100/90 - 19 57M TT Dunlop GEOMAX MX51
Additional information is available in the Service section under: www.husqvarna-motorcycles.com	

22.7 Fork

Fork part number	14.18.7N.55	
Fork	WP Suspension Up Side Down 4860 MXMA CC	
Compression damping		
Comfort	14 clicks	
Standard	12 clicks	
Sport	10 clicks	
Rebound damping		
Comfort	14 clicks	
Standard	12 clicks	
Sport	10 clicks	
Spring length with preload spacer(s)	490 mm (19.29 in)	
Spring rate		
Weight of rider: 65... 75 kg (143... 165 lb.)	4.4 N/mm (25.1 lb/in)	
Weight of rider: 75... 85 kg (165... 187 lb.)	4.6 N/mm (26.3 lb/in)	
Weight of rider: 85... 95 kg (187... 209 lb.)	4.8 N/mm (27.4 lb/in)	
Gas pressure	1.2 bar (17 psi)	
Fork length	940 mm (37.01 in)	
Oil capacity per cartridge	195 ml (6.59 fl. oz.)	Fork oil (SAE 4) (48601166S1) (☛ p. 91)
Oil capacity fork leg without cartridge	390 ml (13.19 fl. oz.)	Fork oil (SAE 4) (48601166S1) (☛ p. 91)

22.8 Shock absorber

Shock absorber part number	18.15.7N.55	
Shock absorber	WP Suspension 5018 BAVP DCC	
Compression damping, low-speed		
Comfort	17 clicks	
Standard	15 clicks	
Sport	13 clicks	
Compression damping, high-speed		
Comfort	2.5 turns	
Standard	2 turns	
Sport	1.5 turns	
Rebound damping		
Comfort	17 clicks	
Standard	15 clicks	

Sport	13 clicks
Spring preload	12 mm (0.47 in)
Spring rate	
Weight of rider: 65... 75 kg (143... 165 lb.)	51 N/mm (291 lb/in)
Weight of rider: 75... 85 kg (165... 187 lb.)	54 N/mm (308 lb/in)
Weight of rider: 85... 95 kg (187... 209 lb.)	57 N/mm (325 lb/in)
Spring length	260 mm (10.24 in)
Gas pressure	10 bar (145 psi)
Static sag	30 mm (1.18 in)
Riding sag	100 mm (3.94 in)
Fitted length	486 mm (19.13 in)
Shock absorber oil	Shock absorber oil (SAE 2.5) (50180342S1) (☛ p. 91)

22.9 Chassis tightening torques

Screw, air filter box lid	EJOT PT® K60x20-Z	3 Nm (2.2 lbf ft)	–
Screw, pressure regulator	EJOT PT®	2.3 Nm (1.7 lbf ft)	–
Spoke nipple, front wheel	M4.5	5... 6 Nm (3.7... 4.4 lbf ft)	–
Spoke nipple, rear wheel	M4.5	5... 6 Nm (3.7... 4.4 lbf ft)	–
Screw, battery terminal	M5	2.5 Nm (1.84 lbf ft)	–
Screw, intake air temperature sensor	M5	2 Nm (1.5 lbf ft)	–
Screw, shock absorber adjusting ring	M5	5 Nm (3.7 lbf ft)	–
Remaining nuts, chassis	M6	10 Nm (7.4 lbf ft)	–
Remaining screws, chassis	M6	10 Nm (7.4 lbf ft)	–
Screw, ball joint of push rod on foot brake cylinder	M6	10 Nm (7.4 lbf ft)	Loctite® 243™
Screw, chain sliding guard	M6	6 Nm (4.4 lbf ft)	Loctite® 243™
Screw, electric starter cable connection	M6	4 Nm (3 lbf ft)	–
Screw, front brake disc	M6	14 Nm (10.3 lbf ft)	Loctite® 243™
Screw, rear brake disc	M6	14 Nm (10.3 lbf ft)	Loctite® 243™
Screw, throttle grip	M6	5 Nm (3.7 lbf ft)	–
Fuel connection on fuel tank	M8	10 Nm (7.4 lbf ft)	–
Nut, foot brake lever stop	M8	20 Nm (14.8 lbf ft)	–
Nut, rear sprocket screw	M8	35 Nm (25.8 lbf ft)	Loctite® 2701™
Nut, rim lock	M8	12 Nm (8.9 lbf ft)	–
Remaining nuts, chassis	M8	25 Nm (18.4 lbf ft)	–
Remaining screws, chassis	M8	25 Nm (18.4 lbf ft)	–
Screw, bottom triple clamp	M8	12 Nm (8.9 lbf ft)	–
Screw, chain sliding piece	M8	15 Nm (11.1 lbf ft)	–
Screw, engine brace	M8	33 Nm (24.3 lbf ft)	Loctite® 2701™
Screw, fork stub	M8	15 Nm (11.1 lbf ft)	–
Screw, front brake caliper	M8	25 Nm (18.4 lbf ft)	Loctite® 243™
Screw, handlebar clamp	M8	20 Nm (14.8 lbf ft)	–
Screw, manifold	M8	15 Nm (11.1 lbf ft)	–
Screw, subframe	M8	30 Nm (22.1 lbf ft)	Loctite® 2701™
Screw, top steering stem	M8	17 Nm (12.5 lbf ft)	Loctite® 243™
Screw, top triple clamp	M8	17 Nm (12.5 lbf ft)	–
Engine carrying screw	M10	60 Nm (44.3 lbf ft)	–
Remaining nuts, chassis	M10	45 Nm (33.2 lbf ft)	–
Remaining screws, chassis	M10	45 Nm (33.2 lbf ft)	–
Screw, bottom shock absorber	M10	60 Nm (44.3 lbf ft)	Loctite® 2701™
Screw, handlebar support	M10	40 Nm (29.5 lbf ft)	Loctite® 243™

Screw, top shock absorber	M10	60 Nm (44.3 lbf ft)	Loctite® 2701™
Nut, fuel pump	M12	15 Nm (11.1 lbf ft)	–
Nut, frame to linkage lever	M14x1.5	80 Nm (59 lbf ft)	–
Nut, linkage lever on swingarm	M14x1.5	80 Nm (59 lbf ft)	–
Nut, linkage lever to angle lever	M14x1.5	80 Nm (59 lbf ft)	–
Nut, swingarm pivot	M16x1.5	100 Nm (73.8 lbf ft)	–
Nut, rear wheel spindle	M20x1.5	80 Nm (59 lbf ft)	–
Screw, top steering head	M20x1.5	12 Nm (8.9 lbf ft)	–
Screw-in nozzles, cooling system	M20x1.5	12 Nm (8.9 lbf ft)	Loctite® 243™
Screw, front wheel spindle	M24x1.5	45 Nm (33.2 lbf ft)	–

Brake fluid DOT 4 / DOT 5.1

Standard/classification

- DOT

Guideline

- Use only brake fluid that complies with the specified standard (see specifications on the container) and that possesses the corresponding properties.

Coolant

Guideline

- Use only suitable coolant (even in countries with high temperatures). Using inferior antifreeze can result in corrosion and foaming.
- Use only coolant based on ethylene glycol.

Mixture ratio

Antifreeze protection: -25... -45 °C (-13... -49 °F)	50 % corrosion inhibitor/antifreeze 50 % distilled water
--	---

Coolant (mixed ready to use)

Guideline

- Use only coolant based on ethylene glycol.

Antifreeze protection	-40 °C (-40 °F)
-----------------------	-----------------

Engine oil (SAE 10W/60)

Standard/classification

- JASO T903 MA (☛ p. 94)
- SAE (☛ p. 94) (SAE 10W/60)
- KTM LC4 2007+

Guideline

- Use only engine oils that comply with the specified standards (see specifications on the container) and that possess the corresponding properties.

Synthetic engine oil

Engine oil (SAE 10W/50)

Standard/classification

- JASO T903 MA (☛ p. 94)
- SAE (☛ p. 94) (SAE 10W/50)

Guideline

- Use only engine oils that comply with the specified standards (see specifications on the container) and that possess the corresponding properties.

Synthetic engine oil

Fork oil (SAE 4) (48601166S1)

Standard/classification

- SAE (☛ p. 94) (SAE 4)

Guideline

- Use only oils that comply with the specified standards (see specifications on the container) and that possess the corresponding properties.

Shock absorber oil (SAE 2.5) (50180342S1)

Standard/classification

- SAE (☛ p. 94) (SAE 2.5)

Guideline

- Use only oils that comply with the specified standards (see specifications on the container) and that possess the corresponding properties.

Super unleaded (ROZ 95/RON 95/PON 91)

Standard/classification

- DIN EN 228 (ROZ 95/RON 95/PON 91)

Guideline

- Only use unleaded super fuel that matches or is equivalent to the specified fuel grade.
- Fuel with an ethanol content of up to 10 % (E10 fuel) is safe to use.



Info

Do **not** use fuel containing methanol (e. g. M15, M85, M100) or more than 10 % ethanol (e. g. E15, E25, E85, E100).

High viscosity grease

Recommended supplier

SKF®

- LGHB 2

Rubber grip adhesive (00062030051)

Recommended supplier

KTM-Sportmotorcycle AG

- GRIP GLUE

JASO T903 MA

Different technical development directions required a new specification for 4-stroke motorcycles – the JASO T903 MA Standard. Earlier, engine oils from the automobile industry were used for 4-stroke motorcycles because there was no separate motorcycle specification. Whereas long service intervals are demanded for automobile engines, high performance at high engine speeds are in the foreground for motorcycle engines. In most motorcycles, the gearbox and the clutch are lubricated with the same oil as the engine. The JASO MA Standard meets these special requirements.

SAE

The SAE viscosity classes were defined by the Society of Automotive Engineers and are used for classifying oils according to their viscosity. The viscosity describes only one property of oil and says nothing about quality.

A	
Accessories	7
Air filter	
cleaning	43
installing	43
removing	43
Air filter box	
cleaning	43
sealing	44
Air filter box lid	
installing	42
removing	42
Antifreeze	
checking	71
Auxiliary substances	7
B	
Basic chassis setting	
checking with rider's weight	26
Battery	
installing	68
recharging	69
removing	68
Blink code	84
Brake discs	
checking	55
Brake fluid	
front brake, adding	56
rear brake, adding	60
Brake fluid level	
front brake, checking	56
rear brake, checking	60
Brake linings	
front brake, changing	57
front brake, checking	57
rear brake, changing	62
rear brake, checking	61
C	
Capacity	
coolant	73, 87
engine oil	78, 87
fuel	23, 87
Chain	
checking	50
cleaning	48
Chain guide	
checking	50
Chain tension	
adjusting	49
checking	49
Chassis number	10
Clutch	
fluid level, checking/correcting	53
fluid, changing	53

Clutch lever	11
basic position, adjusting	53
Cold start button	13
Compression damping	
fork, adjusting	30
Compression damping, high-speed	
shock absorber, adjusting	27
Compression damping, low-speed	
shock absorber, adjusting	26
Coolant	
draining	72
refilling	73
Coolant level	
checking	71-72
Cooling system	71
Customer service	7
D	
Difficult operating conditions	17
Difficult riding conditions	
dry sand	17
high temperatures	19
low speeds	19
low temperatures	19
muddy surfaces	18
snow	19
wet sand	18
wet surfaces	18
E	
Electric starter button	11
Engine	
running in	17
Engine number	10
Engine oil	
adding	79
changing	77
Engine oil level	
checking	76
Engine sprocket	
checking	50
Environment	6
F	
Figures	7
Filler cap	
closing	13
opening	12
Foot brake lever	14
basic position, adjusting	59
free travel, checking	59
Fork legs	
basic setting, checking	30
bleeding	32
compression damping, adjusting	30
dust boots, cleaning	33
installing	34

rebound damping, adjusting	30
removing	33
Fork protector	
installing	35
removing	35
Frame	
checking	51
Front fender	
installing	39
removing	39
Front wheel	
installing	64
removing	64
Fuel screen	
changing	76
Fuel tank	
installing	47
removing	46
Fuse	
main fuse, changing	70
H	
Hand brake lever	11
basic position, adjusting	55
free travel, checking	55
Handlebar position	31
adjusting	31
I	
Idle speed	
adjusting	75
Idle speed adjusting screw	14
Implied warranty	7
Intended use	5
K	
Kill switch	11
L	
Lower triple clamp	
installing	36
removing	35
M	
Main fuse	
changing	70
Main silencer	
glass fiber yarn filling, changing	45
installing	44
removing	44
Map-Select switch	
for the basic setting	12
for vehicle operation	12
Motorcycle	
cleaning	80
raising with lift stand	32
removing from lift stand	32

O	
Oil filter	
changing	77
Oil screen	
cleaning	77
Operating substances	7
Overview of indicator lamps	12
Owner's Manual	6
P	
Plug-in stand	15
Protective clothing	6
Putting into operation	
advice on first use	16
after storage	81
checks and maintenance before putting into operation	20
R	
Rear sprocket	
checking	50
Rear wheel	
installing	65
removing	65
Rebound damping	
fork, adjusting	30
shock absorber, adjusting	27
Refueling	
fuel	22
Riding sag	
adjusting	29
Right side cover	
installing	46
removing	45
Rubber grip	
checking	52
securing	53
S	
Safe operation	5
Seat	
mounting	42
removing	42
Service	7
Service schedule	24-25
Shift lever	
basic position, adjusting	75
basic position, checking	75
Shock absorber	
compression damping, general	26
high speed compression damping, setting	27
installing	41
low speed compression damping, setting	26
rebound damping, adjusting	27
removing	40
riding sag, checking	28
spring preload, adjusting	29
static sag, checking	28

Spare parts	7
Spoke tension	
checking	67
Start number plate	
installing	39
removing	38
Starting	20
Steering head bearing	
greasing	38
Steering head bearing play	
adjusting	38
checking	37
Storage	81
Swingarm	
checking	52
T	
Technical data	
capacities	87
chassis	87
chassis tightening torques	89
electrical system	88
engine	85
engine tightening torques	85
fork	88
shock absorber	88
tires	88
Throttle cable play	
adjusting	74
checking	74
Throttle cable routing	
checking	52
Throttle grip	11
Tire air pressure	
checking	67
Tire condition	
checking	66
Transport	22
Troubleshooting	82-83
Type label	10
U	
Use definition	5
V	
View of vehicle	
front left	8
rear right side	9
W	
Warranty	7
Work rules	6

THE PIONEERS OF MOTOCROSS



3402002en

11/2013



Husqvarna Motorcycles GmbH
Stallhofnerstraße 3 | 5230 Mattighofen
Austria



Photo:
Mitterbauer/Husqvarna
Motorcycles GmbH