

Quick Reference Guide

This Quick Reference Guide will assist you in finding the information you're looking for.

SAFETY INFORMATION

GENERAL INFORMATION

HOW TO RIDE THE MOTORCYCLE

MAINTENANCE AND ADJUSTMENT

APPENDIX

MAINTENANCE RECORD

A Table of Contents is included after the Foreword.

Whenever you see the symbols shown below, heed their instructions! Always follow safe operating and maintenance practices.

 **DANGER**

DANGER indicates a hazardous situation which, if not avoided, will result in death or serious injury.

 **WARNING**

WARNING indicates a hazardous situation which, if not avoided, could result in death or serious injury.

NOTICE

NOTICE is used to address practices not related to personal injury.

NOTE

- *NOTE* indicates information that may help or guide you in the operation or service of the vehicle.

NOTICE

**THIS PRODUCT HAS BEEN
MANUFACTURED FOR USE IN A
REASONABLE AND PRUDENT
MANNER BY A QUALIFIED OP-
ERATOR AND AS A VEHICLE
ONLY.**

Foreword

Congratulations on your purchase of a new Kawasaki motorcycle. Your new motorcycle is the product of Kawasaki's advanced engineering, exhaustive testing, and continuous striving for superior reliability, safety and performance.

Please read this Owner's Manual carefully before riding so that you will be thoroughly familiar with the proper operation of your motorcycle's controls, its features, capabilities, and limitations. This manual offers many safe riding tips, but its purpose is not to provide instruction in all the techniques and skills required to ride a motorcycle safely. Kawasaki strongly recommends that all operators of this vehicle enroll in a motorcycle rider training program to attain awareness of the mental and physical requirements necessary for safe motorcycle operation.

To ensure a long, trouble-free life for your motorcycle, give it the proper care and maintenance described in this manual. For those who would like more detailed information on their Kawasaki Motorcycle, a Service Manual is available for purchase from any authorized Kawasaki motorcycle dealer. The Service Manual contains detailed disassembly and maintenance information. Those who plan to do their own work should, of course, be competent mechanics and possess the special tools described in the Service Manual.

Keep this Owner's Manual aboard your motorcycle at all times so that you can refer to it whenever you need information.

This manual should be considered a permanent part of the motorcycle and should remain with the motorcycle when it is sold.

All rights reserved. No part of this publication may be reproduced without our prior written permission.

This publication includes the latest information available at the time of printing. However, there may be minor differences between the actual product and illustrations and text in this manual.

All products are subject to change without prior notice or obligation.

KAWASAKI HEAVY INDUSTRIES, LTD.
Motorcycle & Engine Company

© 2012 Kawasaki Heavy Industries, Ltd.

Dec. 14, 2012. (1)

TABLE OF CONTENTS

SAFETY INFORMATION	8	GENERAL INFORMATION	19
Read Owner's Manual	8	Specifications	19
Training	8	Serial Number Locations	24
Daily Safety Checks and Periodic Maintenance	8	Location of Labels	25
Loading and Accessories Information	9	Location of Parts	33
Passenger	10	Meter Instruments	36
Baggage and Luggage	11	Tachometer	37
Accessories	11	Multifunction Meter	38
Other Load	12	Indicator Lights	44
If You are Involved in a Accident	12	Warning Indicator Light	45
Safe Operation	13	Keys	46
Carbon Monoxide Hazard	13	Ignition Switch/Steering Lock	47
Fueling	14	Right Handlebar Switches	49
Never Ride with Drugs or Alcohol	14	Left Handlebar Switches	50
Protective Gear and Clothing	14	Fuel Tank Cap	51
Safe Riding Techniques	15	Fuel	51
Additional Considerations for High Speed Operation	17	Fuel Requirements	51
		Filling the Tank	54
		Side Stand	56
		Seats	56

Helmet Hooks.....	59	Throttle Control System	97
Tying Hooks	60	Idle Speed.....	99
Tool Kit/Storage Compartment.....	60	Clutch.....	100
Rear View Mirror	61	Drive Chain	102
Event Data Recorder.....	62	Brakes.....	106
HOW TO RIDE THE MOTORCYCLE .	64	Brake Light Switches.....	109
Break-In	64	Suspension System	110
Starting the Engine	65	Rear Shock Absorber	110
Jump Starting.....	67	Setting Table.....	113
Moving Off.....	70	Wheels	114
Shifting Gears	71	Battery.....	118
Braking.....	72	Headlight.....	122
Stopping the Engine.....	73	Fuses	123
Stopping the Motorcycle in an		General Lubrication.....	125
Emergency	73	Cleaning Your Motorcycle	126
Parking.....	74	General Precautions.....	126
MAINTENANCE AND ADJUSTMENT	76	Washing Your Motorcycle	127
Daily Safety Checks.....	78	APPENDIX	132
Periodic Maintenance.....	81	Storage	132
Engine Oil	86	Troubleshooting Guide.....	135
Coolant.....	89	Environmental Protection.....	136
Air Cleaner	93	MAINTENANCE RECORD	137

SAFETY INFORMATION

Read Owner's Manual

Read this Owner's Manual carefully before riding so that you will be thoroughly familiar with the proper operation of your motorcycle's controls, its features, capabilities, and limitations. This manual offers many safe riding tips, but its purpose is not to provide instruction in all of the techniques and skills required to ride a motorcycle safely.

Training

Kawasaki strongly recommends that all operators of this vehicle complete a suitable motorcycle rider training program to learn the proper skills and techniques necessary for safe motorcycle operation.

Daily Safety Checks and Periodic Maintenance

It is important to keep your motorcycle properly maintained and in safe riding condition. Inspect your motorcycle before every ride and carry out all periodic maintenance. See the Daily Safety Checks section and Periodic Maintenance section in the MAINTENANCE AND ADJUSTMENT chapter for more information.

WARNING

Failure to perform these checks or to correct a problem before operation may result in serious damage or an accident. Always perform daily safety checks before operation.

To ensure your motorcycle is serviced using the latest servicing information, it is recommended that an authorized Kawasaki Dealer performs the periodic maintenance as directed in the Owner's Manual.

If you notice any irregular operating condition, have your motorcycle thoroughly checked at an authorized Kawasaki dealer as soon as possible.

Loading and Accessories Information

WARNING

Incorrect loading, improper installation or use of accessories or modification of your motorcycle may result in an unsafe riding condition. Before you ride the motorcycle, make sure it is not overloaded and that you have followed these instructions.

Maximum Load

Weight of rider, passenger, baggage, and accessories must not exceed 180 kg (397 lb).

With the exception of genuine Kawasaki Parts and Accessories, Kawasaki has no control over the design or application of accessories. In some cases, improper installation

10 SAFETY INFORMATION

or use of accessories, or motorcycle modification, will void the motorcycle warranty; can negatively affect performance, stability and safety; and can even be illegal.

In selecting and using accessories, and in loading the motorcycle, you are personally responsible for your own safety and the safety of other persons involved.

NOTE

○ *Kawasaki Parts and Accessories have been specially designed for use on Kawasaki motorcycles. We strongly recommend that all parts and accessories you add to your motorcycle be genuine Kawasaki components.*

Because a motorcycle is sensitive to changes in weight and aerodynamic forces, you must take extreme care in carrying cargo, passengers and/or in

fitting additional accessories. The following general guidelines have been prepared to assist you in making your determinations.

Passenger

1. Never carry more than one passenger.
2. The passenger should only sit on the pillion.
3. Any passenger should be thoroughly familiar with motorcycle operation. The passenger can affect control of the motorcycle by improper positioning during cornering and sudden movements. It is important that the passenger sits still while the motorcycle is in motion and not interfere with the operation of the motorcycle. Do not carry animals on your motorcycle.

4. Do not carry passengers unless passenger footpegs are installed. Instruct any passenger before riding to keep his or her feet on the passenger footpegs and hold on to the operator or seat strap. Do not carry a passenger unless he or she is tall enough to reach the footpegs with their feet.

Baggage and Luggage

1. All baggage should be carried as low as possible to reduce the effect on the motorcycle's center of gravity. Baggage weight should also be distributed equally on both sides of the motorcycle. Avoid carrying baggage that extends beyond the rear of the motorcycle.
2. Baggage should be securely attached. Make sure that the baggage

will not move around while you are riding. Recheck baggage security as often as possible (not while the motorcycle is in motion) and adjust as necessary.

3. Do not carry heavy or bulky items on a luggage rack. It is designed for light items, and overloading can affect handling due to changes in weight distribution and aerodynamic forces.

Accessories

1. Do not install accessories or carry baggage that impairs the performance of the motorcycle. Make sure that you have not adversely affected any lighting components, road clearance, banking capability (i.e., lean angle), control operation, wheel travel, front fork movement,

12 SAFETY INFORMATION

or any other aspects of the motorcycle's operation.

2. Weight attached to the handlebars or front fork will increase the mass of the steering assembly and can result in an unsafe riding condition.
3. Fairings, windshields, backrests, and other large items have the capability of adversely affecting stability and handling of the motorcycle, not only due to their weight, but also due to the aerodynamic force acting on these surfaces while the motorcycle is in operation. Poorly designed or installed items can result in an unsafe riding condition.

Other Load

1. This motorcycle is not intended to be equipped with a sidecar or to be

used to tow any trailers or other vehicles. Kawasaki does not manufacture sidecars or trailers for motorcycles and cannot predict the effects of such accessories on handling or stability, but can only warn that the effects can be adverse and that Kawasaki cannot assume responsibility for the results of such unintended use of the motorcycle.

2. Furthermore, any adverse effects on motorcycle components caused by the use of such accessories will not be remedied under warranty.

If You are Involved in a Accident

Make sure of your own safety first. Determine the severity of any injuries and call for emergency assistance if needed. Always follow applicable laws

and regulations if any other person, vehicle or property is involved.

Do not attempt to continue riding without first evaluating your motorcycle's condition. Inspect for fluid leaks, check critical nuts and bolts, and check the handlebars, control levers, brakes, and wheels for damage and proper function. Ride slowly and cautiously - your motorcycle may have suffered damage that is not immediately apparent. Have your motorcycle thoroughly checked at a Kawasaki dealer as soon as possible.

Safe Operation

The following should be carefully observed for safe and effective vehicle operation.

Carbon Monoxide Hazard

DANGER

Exhaust gas contains carbon monoxide, a colorless, odorless poisonous gas. Inhaling carbon monoxide can cause serious brain injury or death.

Do not run the engine in enclosed areas. Operate only in a well-ventilated area.

Fueling

 **WARNING**

Gasoline is extremely flammable and can be explosive under certain conditions. To prevent fire or explosion, turn the ignition key off. Do not smoke. Make sure the area is well ventilated and free from any source of flame or sparks; this includes any appliance with a pilot light.

Never Ride with Drugs or Alcohol

Alcohol and drugs impair your judgment and reaction time. Never consume alcohol or drugs before or while riding motorcycles.

Protective Gear and Clothing

Helmet

Kawasaki strongly recommends both the operator and passenger wear a helmet even if this is not a legal requirement.

- Make sure that your helmet fits correctly and is properly fastened.
- Choose a motorcycle helmet that meets the safety standards applicable to your country. Ask your motorcycle dealer to advise you if necessary.

Eye Protection

Always use eye protection. If your helmet does not have a visor installed, wear goggles.

Gloves

Wear gloves which have suitable protection for your hands, especially against abrasion.

Clothing

Wear protective clothing.

- Wear bright, highly visible clothing that allows freedom of movement to suit your riding style.
- Always wear a long-sleeved jacket and long trousers which are abrasion resistant and keep you warm.
- Avoid wearing clothes which have loose cuffs or other fastenings which could interfere with the controls of your motorcycle.

Boots

Wear proper protective boots that fit properly and do not interfere with gear shifting or braking.

Safe Riding Techniques

Keep Hands on Handlebars

When riding always keep both hands on the handlebars and both feet on the footpegs. Removing your hands from the handlebars or feet from the footpegs while riding can be hazardous. If you remove even one hand or foot, you reduce your ability to control the motorcycle.

Look Over Your Shoulder

Before changing lanes, look over your shoulder to make sure the way is clear. Do not rely solely on the rear view mirror; you may misjudge a vehicle's distance and speed, or you may not see it at all.

Accelerate and Brake Smoothly

In general your actions should be smooth as sudden acceleration, braking or turning may cause loss of control, especially when riding in wet conditions or on loose road surfaces, when the ability to maneuver will be reduced.

Select Correct Gear Speeds

When going up steep slopes, shift to a lower gear so that there is power to spare rather than overloading the engine.

Use Both Front and Rear Brakes

When applying the brakes, use both the front and rear brakes. Applying only one brake for sudden braking may cause the motorcycle to skid and lose control.

Use Engine Brake

When going down long slopes, help control vehicle speed by closing the

throttle so that the engine can act as an auxiliary brake. Use the front and rear brakes for primary braking.

Riding in Wet Conditions

Rely more on the throttle to control vehicle speed and less on the front and rear brakes. The throttle should also be used judiciously to avoid skidding the rear wheel from too rapid acceleration or deceleration.

Braking performance is also reduced in wet conditions. Carefully ride at a slow speed and apply the brakes several times to help dry and restores them to normal operating performance.

Lubricate the drive chain after wet-weather riding to prevent rust and corrosion.

Ride Prudently

Riding at the proper speed and avoiding unnecessarily fast acceleration are important not only for safety and low

fuel consumption but also for long vehicle life and quieter operation.

Riding on Rough Roads

Exercise caution, slow down, and grip the fuel tank with the knees for better stability.

Acceleration

When quick acceleration is necessary to pass another vehicle, shift to a lower gear to obtain the necessary power.

Downshifting

To avoid engine damage and rear-wheel lock-up do not downshift at high rpm.

Avoid Unnecessary Weaving

Unnecessary weaving jeopardizes the safety of both the rider and other motorists.

Additional Considerations for High Speed Operation

WARNING

Handling characteristics of a motorcycle at high speeds may vary from those you are familiar with at legal highway speeds. Do not attempt high speed operation unless you have received sufficient training and have the required skills. Do not operate at high speeds on public roads.

Brakes

The importance of the brakes, especially during high speed operation, cannot be overemphasized. Check to

18 SAFETY INFORMATION

see that they are correctly adjusted and functioning properly.

Steering

Looseness in the steering can cause loss of control. Check to see that the handlebars turns freely but has no play.

Tires

High speed operation is hard on tires, and good tires are crucial for safe riding. Examine their overall condition, inflate them to the proper pressure, and check the wheel balance.

Fuel

Have sufficient fuel for the high fuel consumption during high speed operation.

Engine Oil

To avoid engine seizure and resulting loss of control, make sure that the oil level is at the upper level line.

Coolant

To avoid overheating, check that the coolant level is at the upper level line.

Electrical Equipment

Make sure that the headlight, tail/brake light, turn signals, horn, etc., all work properly.

Miscellaneous

Make sure that all nuts and bolts are tight and that all safety related parts are in good condition.

GENERAL INFORMATION

Specifications

PERFORMANCE

Maximum Horsepower	(TH)	23.0 kW (31 PS) @11 000 r/min (rpm)
	(ID, MY, PH)	23.5 kW (32 PS) @11 000 r/min (rpm)
Maximum Torque	(TH)	21.0 N·m (2.1 kgf·m, 15 ft·lb) @8 500 r/min (rpm)
	(ID, MY, PH)	21.0 N·m (2.1 kgf·m, 15 ft·lb) @10 000 r/min (rpm)
Minimum Turning Radius		2.4 m (94 in.)

DIMENSIONS

Overall Length	(TH)	2 015 mm (79.33 in.)
	(ID, MY, PH)	2 010 mm (79.13 in.)
Overall Width		750 mm (29.5 in.)
Overall Height		1 025 mm (40.35 in.)
Wheelbase	(TH)	1 410 mm (55.51 in.)
	(ID, MY, PH)	1 400 mm (55.12 in.)

20 GENERAL INFORMATION

Road Clearance	145 mm (5.71 in.)
Curb Mass	168 kg (370 lb)

ENGINE

Type	DOHC, 2-cylinder, 4-stroke, liquid-cooled
Displacement	249 cm ³ (15.2 cu in.)
Bore x Stroke	62.0 x 41.2 mm (2.44 x 1.62 in.)
Compression Ratio	11.3 : 1
Starting System	Electric starter
Cylinder Numbering Method	Left to right, 1-2
Firing Order	1-2
Fuel System	FI (Fuel Injection)
Ignition System	Battery and coil (transistorized ignition)
Ignition Timing (Electronically advanced)	10° BTDC @1 300 r/min (rpm) ~ 39° BTDC @4 000 r/min (rpm)
Spark Plug: Type	NGK CR8E
Gap	0.7 ~ 0.8 mm (0.028 ~ 0.031 in.)
Lubrication System	Forced lubrication (wet sump)

Engine Oil:	Type	API SG, SH, SJ, SL, or SM with JASO MA, MA1 or MA2
	Viscosity	SAE 10W-40
	Capacity	2.4 L (2.5 US qt)
Coolant Capacity		1.5 L (1.6 US qt)

TRANSMISSION

Transmission Type		6-speed, return shift
Clutch Type		Wet, multi disc
Driving System		Chain drive
Primary Reduction Ratio		3.087 (71/23)
Final Reduction Ratio	(TH)	3.143 (44/14)
	(ID, MY, PH)	3.286 (46/14)
Overall Drive Ratio	(TH)	8.662 (Top gear)
	(ID, MY, PH)	9.056 (Top gear)
Gear Ratio:	1st	2.600 (39/15)
	2nd	1.789 (34/19)

22 GENERAL INFORMATION

3rd	1.409 (31/22)
4th	1.160 (29/25)
5th	1.000 (27/27)
6th	0.893 (25/28)

FRAME

Castor	26°
Trail	82 mm (3.2 in.)
Tire Size:	Front 110/70-17M/C 54S
	Rear 140/70-17M/C 66S
Rim Size:	Front J17M/C x MT2.75
	Rear J17M/C x MT4.00
Fuel Tank Capacity	17 L (4.5 US gal)
Brake Fluid:	Front DOT3 or 4
	Rear DOT4

ELECTRICAL EQUIPMENT

Battery	12 V 8 Ah
---------	-----------

Headlight:	High Beam	12 V 55 W + 55 W
	Low Beam	12 V 55 W
Tail/Brake Light		12 V 5/21 W

TH: Thailand model

ID: Indonesia model

MY: Malaysia model

PH: Philippines model

Specifications are subject to change without notice, and may not apply to every country.

Serial Number Locations

The engine and frame serial numbers are used to register the motorcycle. They are the only means of identifying your particular machine from others of the same model type. These serial numbers may be needed by your dealer when ordering parts. In the event of theft, the investigating authorities will require both numbers as well as the model type and any peculiar features of your machine that can help them identify it.

Engine No.

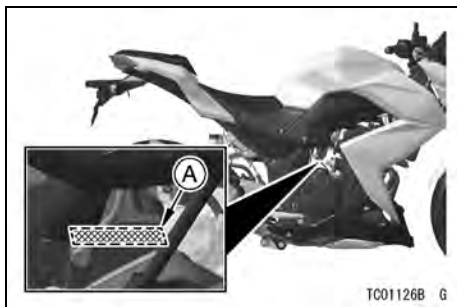

A. Engine Number

Frame No.



A. Frame Number

Location of Labels

All warning labels which are on your vehicle are repeated here. Read labels on your vehicle and understand them thoroughly. They contain information which is important for your safety and the safety of anyone else who may operate your vehicle. Therefore, it is very important that all warning labels be on your vehicle in the locations shown. If any label is missing, damaged, or worn, get a replacement from your Kawasaki dealer and install it in the correct position.

NOTE

- *The sample warning labels in this section have part numbers to help*

you and your dealer obtain the correct replacement.

- *Refer to the actual vehicle label for model specific data grayed out in the illustration.*

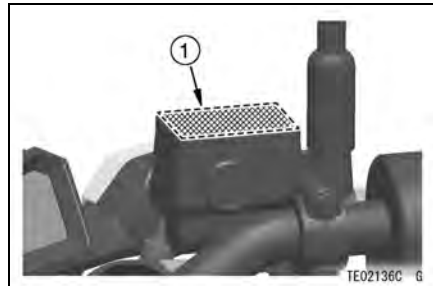

1. Brake Fluid (Front)

26 GENERAL INFORMATION

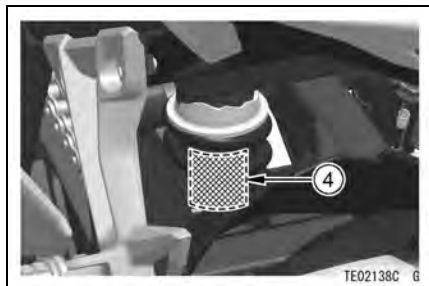
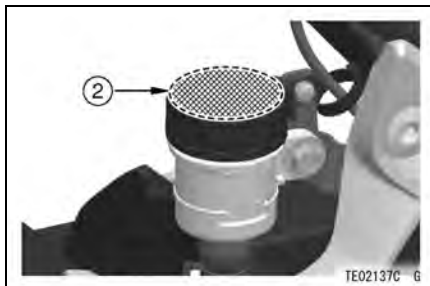

- 2. Brake Fluid (Rear)
- 3. Battery Poison/Danger
- 4. Rear Shock Absorber Warning

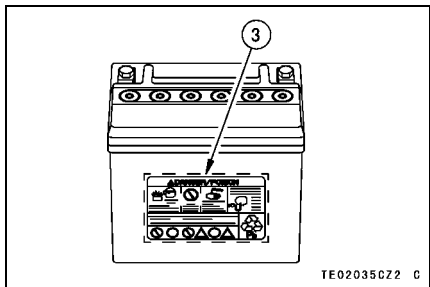

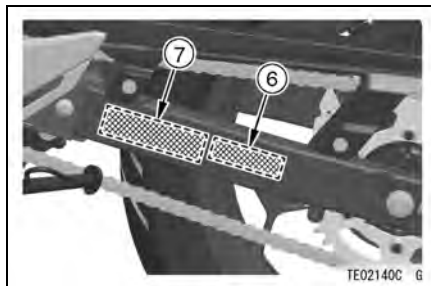
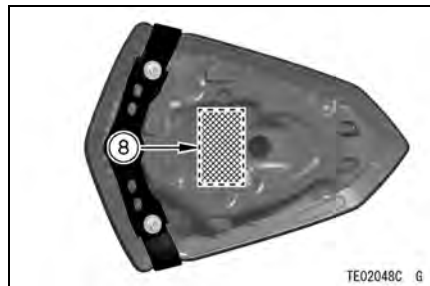
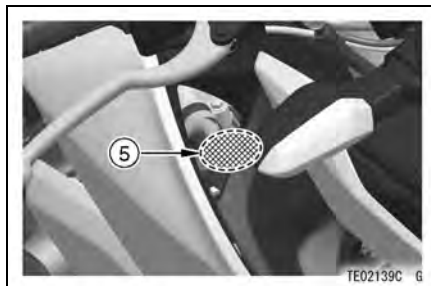

- 5. Radiator Cap Danger
- 6. Important Drive Chain Information
- 7. Tire and Load Data
- 8. Daily Safety Checks

28 GENERAL INFORMATION

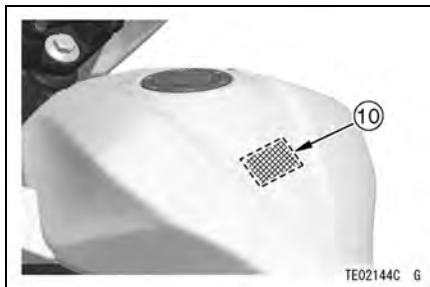
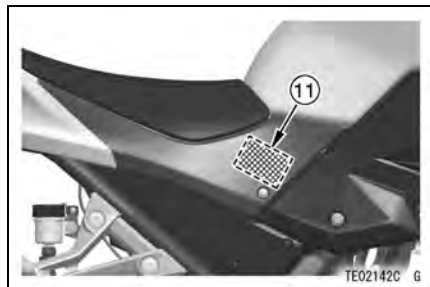
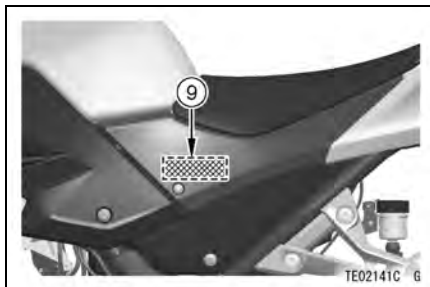

- *9. Vehicle Emission Control Information
- **10. Helmet Wearing
- **11. Vacuum Hose Routing Diagram

*: Only on Philippines model
**: Only on Thailand model

1)

USE ONLY DOT3 OR 4 BRAKE
FLUID FROM A SEALED CONTAINER.
CLEAN FILLER CAP
BEFORE REMOVING.
WARNING
UTILISER DU LIQUIDE
DE FREIN DOT3 OU 4.

TE03816BN9 C

2)



TE03491DN9 C

3)

⚠ DANGER/POISON			
 SHIELD EYES EXPLOSIVE GASES CAN CAUSE BLINDNESS OR INJURY	 NO • SPARKS • FLAMES • SMOKING	 SULFURIC ACID CAN CAUSE BLINDNESS OR SEVERE BURNS	FLUSH EYES IMMEDIATELY WITH WATER GET MEDICAL HELP FAST
KEEP OUT OF THE REACH OF CHILDREN.			
IN U.S.A., DISTR. BY KAWASAKI MOTORS CORP., USA P.O. BOX 25252 SANTA ANA, CA. 92799-5252			LEAD RECYCLE RETURN CSS9

TE03351D S

30 GENERAL INFORMATION

4)

⚠ WARNING
This unit contains high pressure nitrogen gas. Mishandling can cause explosion. ● Do not incinerate, puncture or open.
⚠ AVERTISSEMENT
Cette unité contient de l'azote à haute pression. Une mauvaise manipulation peut entraîner d'explosion. ● Ne pas brûler ni perforer ni ouvrir.
⚠ 警告
高圧窒素ガス入ります。 取り扱いを誤ると爆発する恐れがあります。 ● 火中への投入、穴あけ、分解はしないでください。

TE03352D S

5)

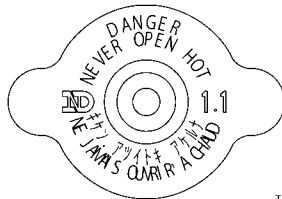

TE03353D S

6)

IMPORTANT DRIVE CHAIN INFORMATION
To prevent an accident and/or damage to the motorcycle, the drive chain must be properly maintained. It should be lubricated every 600km (600L) and adjusted as often as necessary to keep the clearance between the sprockets at 15mm (0.591in) measured midway between sprockets on the lower chain run. Use the motorcycle at the side stand. The standard chain is a 520SAPV with an estimated service life of 18000-20000km (11000-12500mi) depending on the conditions of use and the frequency of lubrication and adjustment. For safety, replace the chain when the standard drive chain has worn to over 20mm (0.787in) regardless of the mileage on the sprockets and with 99410x412510's condition. See the Owner's Manual for chain information.

56033-0786

TE03630D S

7)

TIRE AND LOAD DATA			
The stability and handling characteristics of this motorcycle could become unsafe by the use of improper tire inflation pressures, over worn tires, unsuitable replacement tires, or overloading, when tire tread wears down to the limit, replace the tire with only the standard tire. Maintain the inflation pressure specified.			
	Air Pressure(Cold)	Size & Make Type (Tubless Tire)	Minimum Tread Depth
Front	200 kPa (2.0bar/29.0psi)	110/70-17M/C 54S ROAD WINNER RX-012 TL	1 mm (0.04in)
Up to 180kg Load (397lbs)			
Rear	225 kPa (2.25bar/32.6psi)	140/70-17M/C 66S ROAD WINNER RX-012 2D TL	Up to 130 km/h(80MPH) 2 mm(0.08in) Over 130 km/h(80MPH) 3 mm(0.12in)

56053-0732

TE03627D S

8)

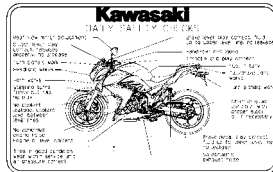

56033-0787

TE03631D S

9) only on Philippines model

VEHICLE EMISSION CONTROL INFORMATION			
ENGINE FAMILY CODE	XXXXXXXXXX	EXHAUST EMISSION CONTROL SYSTEM	XXXXXXXXXX
MODEL YEAR	XXXX	DISP. ADJUST	XXXX CC
EPA EMISSION REGULATIONS			
TYPE	XXXXXXXXXX	SPARK PLUG	XXXXXXXXXX
TYPE A/F RATIO MIXTURE SETTING	NO ADJUSTMENT	SPARK PLUG GAP	XXXXXXXXXX
ST. FLOW 45, 15/16"	NO ADJUSTMENT	ENGINE OIL	SAE 10W 40
IGNITION TIMING	NO ADJUSTMENT	TRANSMISSION OIL	API SE, SI, SL, SJ OR SN 10W 75/90 W
TYPE	XXXXXXXXXX	EXHAUST GAS	NO
EPA EMISSION REGULATIONS TO WHICH THIS MOTORCYCLE COMPLIES: CARBON MONOXIDE (CO), HYDROCARBON (HC), NITROGEN DIOXIDE (NO ₂), NITROGEN MONOXIDE (NO), PARTICULATE MATTER (PM), OXIDES OF NITROGEN (NO _x) REGULATION. KAWASAKI MOTORS (PHILIPPINES) CORPORATION			



TE03555D S

10) only on Thailand model



56071-0023

TE02995B S

32 GENERAL INFORMATION

11) only on Thailand model

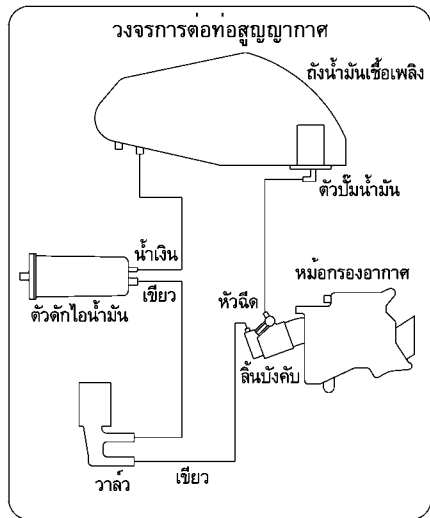

59465-1103

TE03629D S

Location of Parts

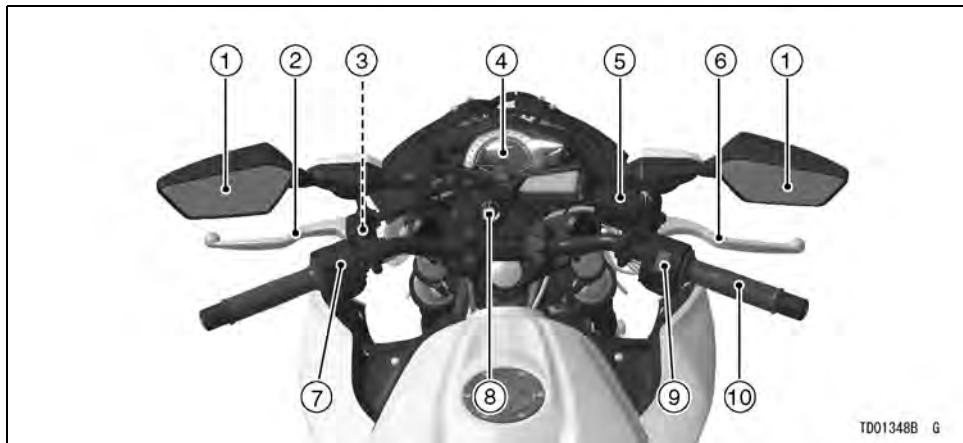

1. Rear View Mirrors
2. Clutch Lever
3. Starter Lockout Switch
4. Meter Instruments
5. Brake Fluid Reservoir (Front)

6. Front Brake Lever
7. Left Handlebar Switches
8. Ignition Switch/Steering Lock
9. Right Handlebar Switches
10. Throttle Grip

34 GENERAL INFORMATION

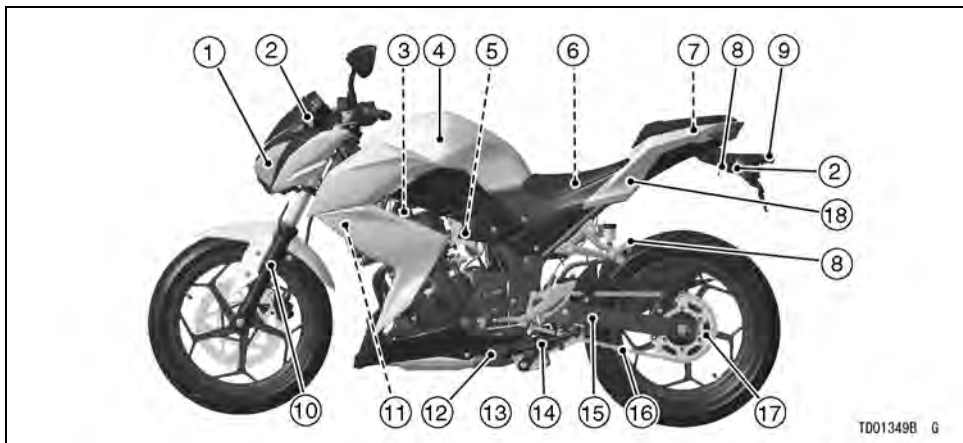

TD01349B G

1. Headlight
2. Turn Signal Lights
3. Spark Plugs
4. Fuel Tank
5. Idle Adjusting Screw
6. Battery and Fuse Box

7. Tool Kit
8. Tying Hooks
9. License Plate Light
10. Front Fork
11. Radiator
12. Side Stand Switch

13. Shift Pedal
14. Side Stand
15. Swingarm
16. Drive Chain
17. Chain Adjuster
18. Seat Lock

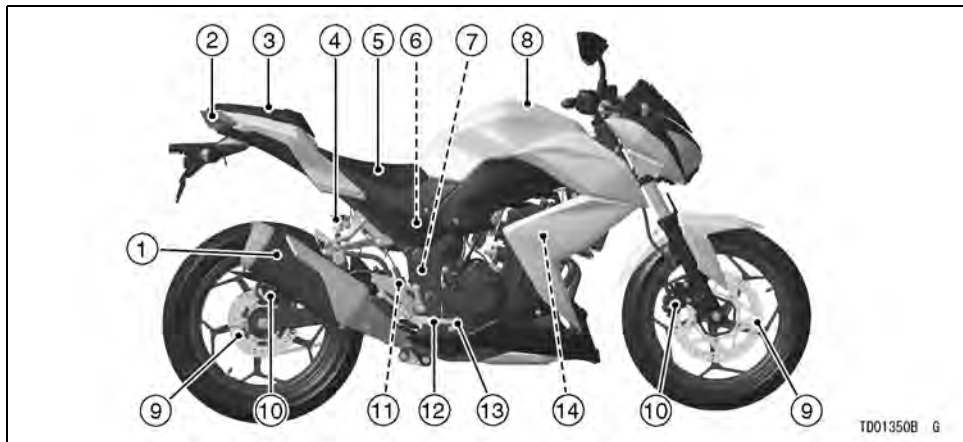

1. Muffler
2. Tail/Brake Light
3. Passenger's Seat
4. Brake Fluid Reservoir (Rear)
5. Rider's Seat
6. Air Cleaner
7. Rear Shock Absorber

8. Fuel Tank Cap
9. Brake Discs
10. Brake Calipers
11. Rear Brake Light Switch
12. Rear Brake Pedal
13. Oil Level Inspection Window
14. Coolant Reserve Tank

Meter Instruments

- A. Green Neutral Indicator Light
- B. Red Battery Voltage Warning Indicator Light
- C. Red Oil Pressure Warning Indicator Light
- D. Red Coolant Temperature Warning Indicator Light
- E. Yellow Engine Warning Indicator Light
- F. Blue High Beam Indicator Light
- G. Green Right Turn Signal Indicator Light
- H. Green Left Turn Signal Indicator Light
- I. Left Button
- J. Right Button
- K. Tachometer
- L. Red Zone
- M. Multifunction Meter

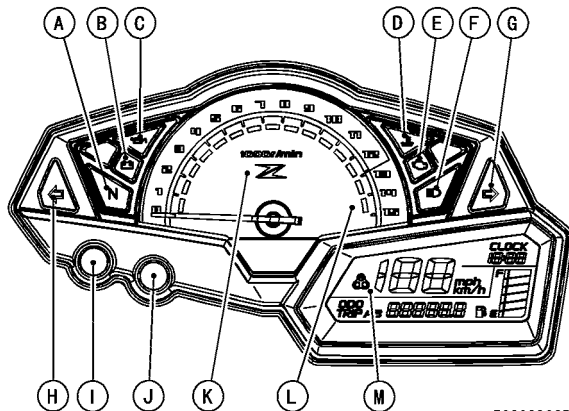

T602096CZ7 G

NOTE

- For safety, do not operate the instrument buttons while riding the motorcycle.

Tachometer

The tachometer shows the engine speed in revolutions per minute (r/min, rpm). On the right side of the tachometer face is a portion called the “red zone.” Engine r/min (rpm) in the red zone is above maximum recommended engine speed and is also above the range for good performance.

NOTICE

Engine r/min (rpm) should not be allowed to enter the red zone; operation in the red zone will overstress the engine and may cause serious engine damage.

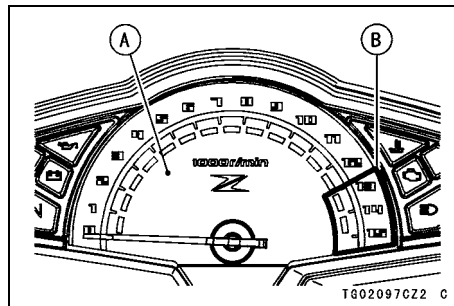

- A. Tachometer**
B. Red Zone

When the ignition switch is turned on, the tachometer needle momentarily goes from the minimum to the maximum, then goes back from the maximum to the minimum reading to check its operation. If the tachometer does not operate correctly, have it checked by an authorized Kawasaki dealer.

Multifunction Meter

- A. Economical Riding Indicator
- B. Speedometer
- C. Clock
- D. Multifunction Display
 - Odometer
 - Trip Meter A
 - Trip Meter B
- E. Fuel Gauge

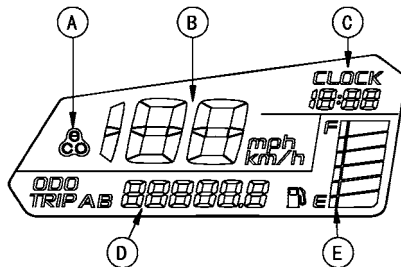

TG02999BZ2 C

When the ignition switch is turned on, all LCD segments are displayed with opening display functions for few seconds, then the multifunction meter turns to operational mode.

Speedometer

The speedometer shows the speed of the vehicle in digital values.

Unit Setting

The unit setting in the meter instrument can be changed according to local regulations. Make sure the unit setting is correctly displayed before riding.

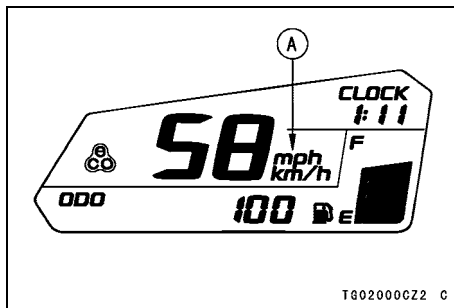

A. mph or km/h Display

NOTE

○ Do not operate the motorcycle with wrong unit (mph or km/h) of the speedometer.

To change the meter display unit in the meter instrument as follows:

- Push the left button to display the odometer.
- Push the right button while pushing the left button to select the display unit.

km/h ← → mph

Multifunction Display

The following display modes can be shifted by pushing the left button.

Odometer → Trip meter A → Trip meter B → Odometer...

NOTE

- For safety, do not operate the instrument buttons while riding the motorcycle.
- The multifunction display is displayed in the unit depending on the unit mode setting, refer to the Unit Setting item in this section.

Odometer

The odometer shows the total distance in kilometers or miles that the vehicle has been ridden. This meter cannot be reset.



A. Odometer

NOTE

- The data is maintained even if the battery is disconnected.
- When the figures come to 999999, they are stopped and locked.

Trip Meter

The trip meters show the distance in kilometers or miles traveled since they were last reset to zero.

TRIP A: 0.0 ~ 9999.9

TRIP B: 0.0 ~ 9999.9



A. Trip Meter A

To reset the trip meter, do the followings while the motorcycle is at the stop.

- Push the left button to display the trip meter A or B.

- Push the right button and hold it in.
- After two seconds, the figure display turns to 0.0, and then starts counting when the vehicle is operated. The meter counts until it is reset.

NOTE

- *The data is maintained by the back-up power if the ignition switch is turned off.*
- *When the trip meter reaches 9999.9 while running, the meters reset to 0.0 and continues counting.*
- *When the battery is disconnected, the meter display resets to 0.0.*

Clock

To adjust hours and minutes, do the followings while the motorcycle is at a stop.

- Turn the ignition switch on.
- Push the left button to display the odometer.

- Push the right button for more than two seconds. Both the hour and minute displays start blinking.

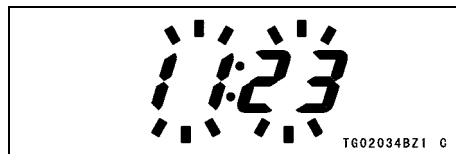

- Push the right button. The hour display only blinks. Push the left button to advance the hours.



- Push the right button. The hour display stops blinking and the minute display starts blinking. Push the left button to advance the minutes.

42 GENERAL INFORMATION

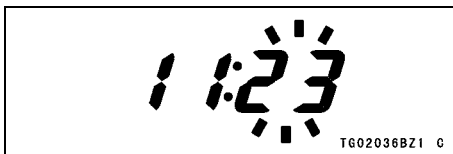

- Push the right button. Both the hour and minute displays start blinking again.
- Push the left button. The displays stop blinking and the clock starts working.

NOTE

- Pushing the left button momentarily advances the hour or minute step by step. Pushing and holding the button advances the hour or minute continuously.
- The clock works normally by the back-up power while the ignition switch is turned off.

- When the battery is disconnected, the clock is reset to 1:00 and starts working again when the battery is connected.

Economical Riding Indicator

When the operator is driving the motorcycle for optimum fuel-efficiency, the economical riding indicator appears on the multifunction meter to indicate favorable fuel consumption. Monitoring the economical riding indicator can help the rider maximize fuel efficiency.



A. Economical Riding Indicator

 **WARNING**

Failing to properly observe the road ahead increases the chance of an accident resulting in severe injury or death. Do not concentrate on the economical riding indicator by taking your eyes off the road; observe using peripheral vision.

Fuel Gauge

The fuel in the fuel tank is shown by the number of segments displayed.

When the fuel tank is full, all the segments are displayed. If the fuel gauge is not correctly displayed, have

the fuel gauge checked by an authorized Kawasaki dealer.

As the fuel level in the tank goes down, the segments disappear one by one from F (full) to E (empty).

The bottom segment and fuel symbol blink in the multifunction meter when approximately 3.5 L (0.9 US gal) of usable fuel remains. Refuel at the earliest opportunity if the most bottom segment of the fuel gauge and fuel symbol blink.

When vehicle stands with the side stand, the fuel gauge cannot show the amount of fuel in the fuel tank exactly. Stand upright the vehicle to check the fuel level.

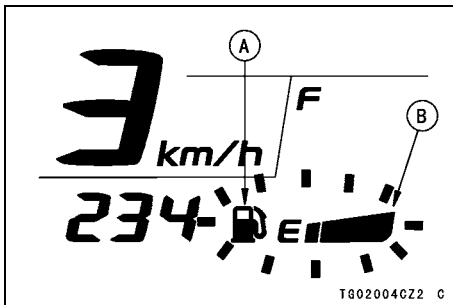

- A. Fuel Symbol ()
B. Segment (E)

All of the segments and fuel symbol will blink in case of the open or short of the wiring. Have the wiring inspected by an authorized Kawasaki dealer immediately.

Indicator Lights

Green Neutral Indicator Light

N: When the transmission is in neutral, the neutral indicator light goes on.

Blue High Beam Indicator Light

 : When the headlight is on high beam, the high beam indicator light goes on.

Green Turn Signal Indicator Light

 : When the turn signal switch is pushed to the left or right, the corresponding turn signal indicator light blinks.

Warning Indicator Light

Red Battery Voltage Warning Indicator Light

 : The battery voltage warning indicator light goes on whenever the battery voltage is less than 11 V or higher than 16 V.

If this light goes on, have the battery checked by an authorized Kawasaki dealer.

Red Oil Pressure Warning Indicator Light

 : The oil pressure warning indicator light should go on whenever the ignition switch is turned on and go off after starting the engine.

This light goes on whenever the oil pressure is dangerously low while the engine running. If this light goes on,

have the engine lubrication system checked by an authorized Kawasaki dealer.

NOTICE

If the engine oil gets extremely low or if the oil pump does not function properly or oil passages are clogged, the warning indicator light in the meter instruments will go on. If it goes on when the engine speed is above idle, stop the engine immediately and have it serviced. Failure to do so could cause serious engine damage.

Red Coolant Temperature Warning Indicator Light

 : The coolant temperature warning indicator light goes on whenever the coolant temperature rises to 118°C

46 GENERAL INFORMATION

(245°F) when the motorcycle is in operation. If this light goes on, stop the engine and check the coolant level in the reserve tank after the engine cools down, then have the cooling system checked by an authorized Kawasaki dealer.

NOTICE

Do not let the engine continue running when the warning indicator light goes on. Prolonged engine operation will result in severe damage from overheating.

Yellow Engine Warning Indicator Light

 : The engine warning indicator light goes on when the ignition switch is turned on and goes off soon after

ensuring that its circuit functions properly. This light also goes on or blinking whenever the troubles occur in digital fuel injection (DFI) system.

The blinking of this light indicates the condition that the engine cannot be started.

Refer to the Stopping the Engine section in the HOW TO RIDE THE MOTORCYCLE chapter for more information. If this light goes on, have the DFI system checked by an authorized Kawasaki dealer.

Keys

This motorcycle has a combination key, which is used for the ignition switch, steering lock, seat lock, and fuel tank cap.

Blank keys are available at your Kawasaki dealers. Ask your dealer to make any additional spare keys you

may need, using your original key as a master.

Ignition Switch/Steering Lock

This is a three-position, key-operated switch. The key can be removed from the switch when it is in the “OFF” or “LOCK” position.

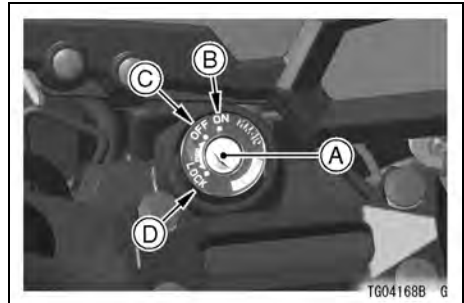

- A. Ignition Switch/Steering Lock
- B. ON position
- C. OFF position
- D. LOCK position

OFF	Engine off. Electrical circuits off.
ON	Engine on. All electrical equipment can be used.
LOCK	Steering locked. Engine off. Electrical circuits off.

NOTE

- *The tail, city and license plate lights are on whenever the ignition key is in the "ON" position. Headlights go on when the starter button is released after starting the engine. To avoid battery discharge, always start the engine immediately after turning the ignition key to "ON."*
- *If you leave the key in the "ON" position on for a long time, the battery may become totally discharged.*

To operate the ignition Switch:

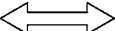
OFF  ON



LOCK

1. Turn the handlebar fully to the left.
2. For locking push down the key in the OFF position and turn it to LOCK.

T804128B22 C

Right Handlebar Switches

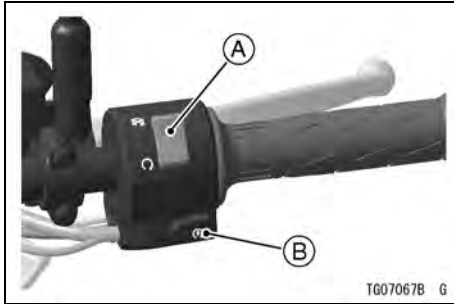

- A. Engine Stop Switch
- B. Starter Button

Engine Stop Switch

In addition to the ignition switch, the engine stop switch must be in the  position for the motorcycle to operate.

The engine stop switch is for emergency use. If required, move the switch to the  position.

NOTE

- *Although the engine stop switch stops the engine, it does not turn off all the electrical circuits. Ordinarily, the ignition switch should be used to stop the engine.*

Starter Button

The starter button operates the electric starter when the transmission is in neutral.

Refer to the Starting the Engine section in the HOW TO RIDE THE MOTORCYCLE chapter for starting instructions.

Left Handlebar Switches

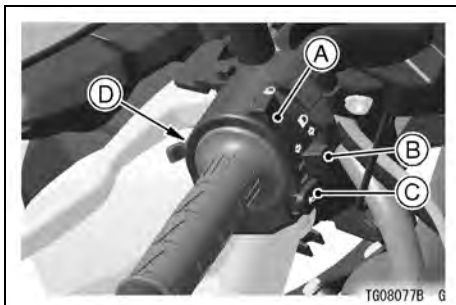

- A. Dimmer Switch
- B. Turn Signal Switch
- C. Horn Button
- D. Passing Button



Dimmer Switch

High or low beam can be selected with the dimmer switch. When the headlight is on high beam (), the high beam indicator light goes on.

High beam.....()

Low beam.....()

Turn Signal Switch

When the turn signal switch is turned to the left () or right (), the corresponding turn signals blink on and off.

To stop blinking, push the switch in.

Horn Button

When the horn button is pushed, the horn sounds.

Passing Button

When the passing button is pushed, the headlight high beam (passing beam) goes on to signal the driver of the vehicle ahead that you are about to pass. The passing light is shut off as soon as the button is released.

Fuel Tank Cap

To open the fuel tank cap, pull up the key hole cover. Insert the ignition key into the fuel tank cap and turn the key to the right.

To close the cap, push it down into place with the key inserted. The key can be removed by holding down the cap and turning it to the left to the original position. Close the key hole cover.

NOTE

- *The fuel tank cap cannot be closed without the key inserted, and the key cannot be removed unless the cap is locked properly.*
- *Do not push on the key to close the cap, or the cap cannot be locked.*

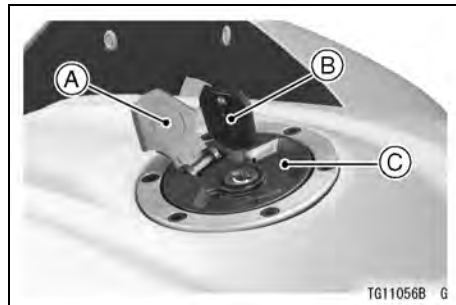

- A. Key Hole Cover
- B. Ignition Key
- C. Fuel Tank Cap

Fuel

Fuel Requirements

Your Kawasaki engine is designed to use only unleaded gasoline with a minimum octane rating shown below.

52 GENERAL INFORMATION

Never use gasoline with an octane rating lower than the minimum specified by Kawasaki to prevent severe engine damage.

The octane rating of a gasoline is a measure of its resistance to detonation or “knocking”. The term commonly used to describe a gasoline’s octane rating is the Research Octane Number (RON).

NOTICE

Do not use leaded gasoline, as this will destroy the catalytic converter.

NOTICE

If engine “knocking” or “pinging” occurs, use a different brand of gasoline of a higher octane rating. If this condition is allowed to continue, it can lead to severe engine damage. Gasoline quality is important. Fuels of low quality or not meeting standard industry specifications may result in unsatisfactory performance. Operating problems that result from the use of poor quality or no recommended fuel may not be covered under your warranty.

Fuel Type and Octane Rating**(Except for Philippines and Thailand Specifications)**

Use clean, fresh unleaded gasoline with an octane rating equal to or higher than that shown in the table.

Fuel Type	Unleaded Gasoline
Minimum Octane Rating	Research Octane Number (RON) 91

NOTICE

Do not use any fuel with an ethanol in this vehicle. It has not been tested and certified for use with such fuels. Damage to the engine and fuel system, or engine starting and/or performance problems may result from the use of improper fuel.

(For Philippines and Thailand Specification)

Use clean, fresh unleaded gasoline with an ethanol volume content not more than 10 % and an octane rating equal to or higher than that shown in the table.

Fuel Type	Unleaded Gasoline
Ethanol Content	E10 or less
Minimum Octane Rating	Research Octane Number (RON) 91

NOTICE

Do not use any fuel that contains more ethanol or other oxygenates than specified for E10 fuel* in this vehicle. Damage to the engine and fuel system, or engine starting and/or performance problems may result from the use of improper fuel.

*E10 means fuel containing up to 10% ethanol.

Filling the Tank

Avoid filling the tank in the rain or where heavy dust is blowing so that the fuel does not get contaminated.

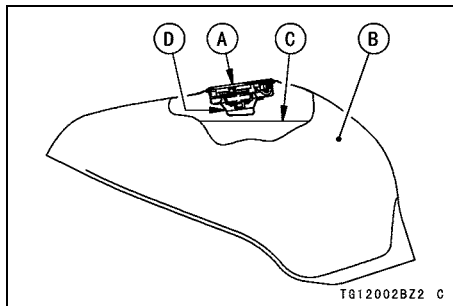

- A. Tank Cap
- B. Fuel Tank
- C. Top Level
- D. Filler Neck

 **WARNING**

Gasoline is extremely flammable and can be explosive under certain conditions, creating the potential for serious burns. Turn the ignition switch off. Do not smoke. Make sure the area is well ventilated and free from any source of flame or sparks; this includes any appliance with a pilot light. Never fill the tank completely to the top. If the tank is filled completely to the top, heat may cause the fuel to expand and overflow through the vents in the tank cap. After refueling, make sure the tank cap is closed securely. If gasoline is spilled on the fuel tank, wipe it off immediately.

NOTICE

Thailand model only:
Never fill the tank so the fuel level rises into the filler neck. If the tank is overfilled, heat may cause the fuel to expand and flow into the Evaporative Emission Control System resulting in hard starting and engine hesitation and non compliance with the emission regulation.

NOTICE

Certain ingredients of in gasoline may cause paint fading or damage. Be extra careful not to spill gasoline or gasoline oxygenates blends during refueling.

Side Stand

The motorcycle is equipped with the side stand.

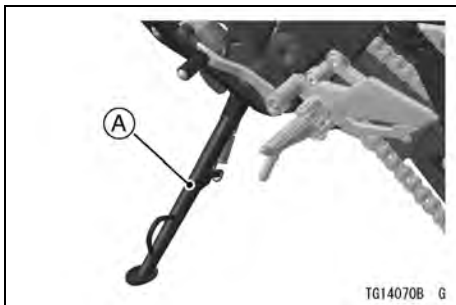

A. Side Stand

NOTE

- *When using the side stand, turn the handlebars to the left.*

Do not sit on the motorcycle while it is on its side stand. Always kick the stand fully up before sitting on the motorcycle.

NOTE

- *Other than Indonesia model, the motorcycle is equipped with a side stand switch. This switch is designed so that the engine does not start if the transmission is in gear and the side stand is down.*

Seats

Rider's Seat Removal

- Remove the bolts and collars on the left and right side covers.
- Pull the left and right side covers to the outside for detaching the projections.

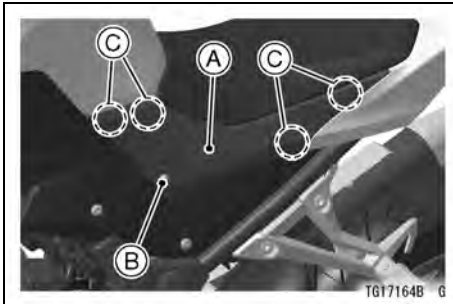

- A. Side Cover (Left Side)
- B. Bolt and Collar
- C. Projections

- Remove the bolts and collars on the rider's seat, and pull off the seat to the up and rear.

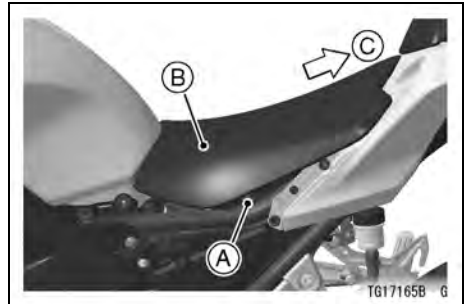

- A. Bolt and Collar (Left Side)
- B. Rider's Seat
- C. Pull Up and Rear

Rider's Seat Installation

Install the rider's seat in the reverse order of removal.

- Insert the tabs on the rear of the rider's seat into the slots on the frame.

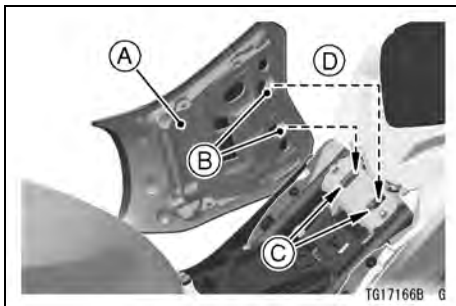

- A. Rider's Seat
- B. Tabs
- C. Slots
- D. Insert

- Install the collars and tighten the bolts.
- Install the left and right side covers, collars and tighten the bolts.

Passenger's Seat Removal

- Remove the passenger's seat by inserting the ignition key into the seat lock, and turning it clockwise.

- Pull up the front of seat, and remove the passenger's seat by pushing it to the front.

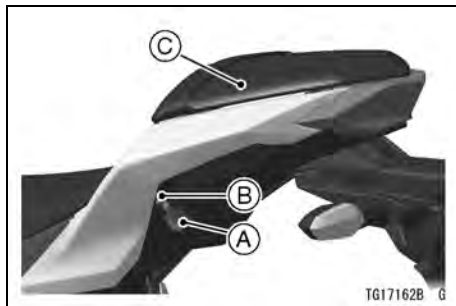

- A. Ignition Key
- B. Seat Lock
- C. Passenger's Seat

Passenger's Seat Installation

Install the passenger's seat in the reverse order of removal.

- Insert the tabs in rear of the passenger's seat into the slots of the bracket.

- Insert the projection in front of the passenger's seat into the hole on the frame.

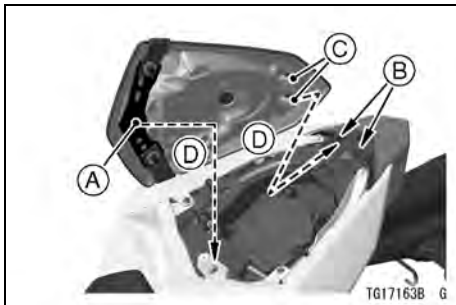

- A. Projection
- B. Slots
- C. Tabs
- D. Insert

- Push down the front part of the passenger's seat until the lock clicks.

- Pull up the front and rear ends of the passenger's seat to make sure they are securely locked.

Helmet Hooks

Helmets can be secured to the motorcycle using the helmet hooks. The helmet hooks are located under the passenger's seat.

⚠ WARNING

Riding with helmets attached to the hooks could cause an accident by distracting the operator or interfering with normal vehicle operation. Do not ride the motorcycle with helmets attached to the hooks.

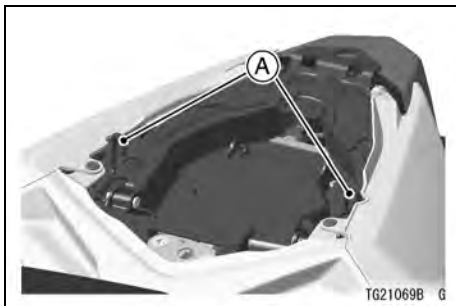

A. Helmet Hooks

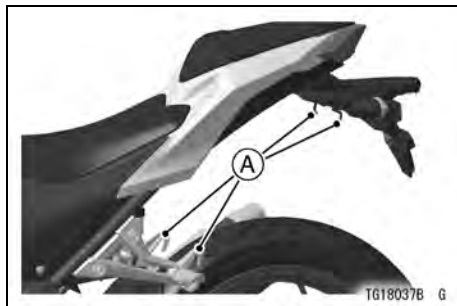

A. Tying Hooks

Tying Hooks

When tying up light loads to the seat, use the tying hooks located in front of the rear turn signal lights and rear of the rear footpegs.

Tool Kit/Storage Compartment

The tool kit and storage compartment is located under the passenger's seat.

The kit contains tools that can be helpful in making roadside repairs, adjustments, and some maintenance procedures explained in this manual.

Keep the tool kit in the storage compartment.

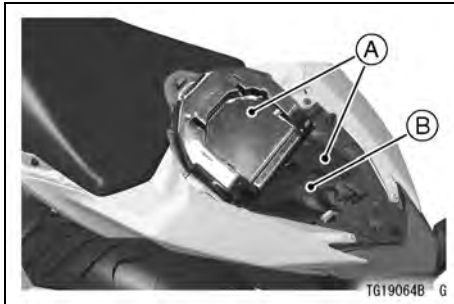

A. Storage Compartment
B. Tool Kit

Rear View Mirror

Rear View Mirror Adjustment

- Adjust the rear view mirror by slightly moving only the mirror portion of the assembly.

- If the rear visibility can not be assured by moving the mirror, loosen the upper hexagonal area and turn the stay by hand.

NOTE

- *The upper hexagonal area (locknut) has left hand threads.*

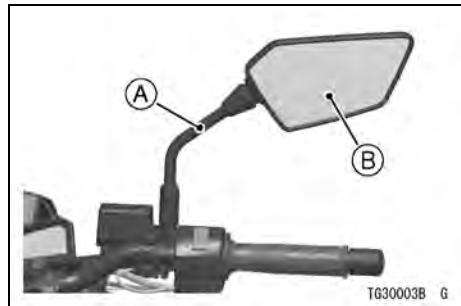

A. Stay
B. Rear View Mirror

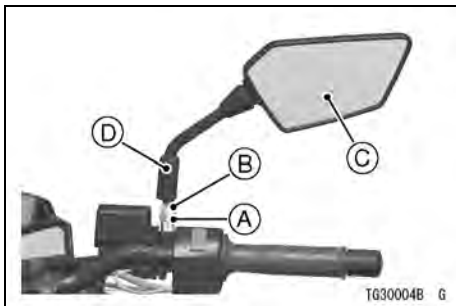

- A. Lower Hexagonal Area for Tightening
- B. Upper Hexagonal Area
- C. Rear View Mirror
- D. Rubber Boots

Event Data Recorder

In common with many other vehicle manufacturers, Kawasaki has equipped this motorcycle with an event data recorder (EDR). The purpose of this device is to record data, only in

accident situation, that assists with understanding of how a vehicle's systems were performing during a short period of time immediately before and during an accident (event).

NOTE

- *During normal riding data is recorded but is constantly overwritten and then erased when the ignition is switched off.*
- *At no time other than in the event of an accident is EDR data stored for retrieval.*
- *This device does not collect or store personal data or information (e.g. name, gender, age).*

This data can help provide a better understanding for both the rider and the manufacturer of how the vehicle was performing at the time of an accident and of the circumstances in which crashes occur.

The EDR in this vehicle is designed to record only data that is relevant to the vehicle's running condition at the time of an accident such information as:

- Vehicle speed,
- Engine crankshaft rotational speed, and
- Throttle opening.

To access information on an EDR, special equipment and access to the EDR is required. Kawasaki will not share EDR information without obtaining your consent, unless required by government authorities, or acting pursuant to lawful authority.

HOW TO RIDE THE MOTORCYCLE

Break-In

The first 1 600 km (1 000 mi) that the motorcycle is ridden is designated as the break-in period. If the motorcycle is not used carefully during this period, you may very well end up with a “broken down” instead of a “broken in” motorcycle after a few thousand kilometers.

The following rules should be observed during the break-in period.

- The table shows maximum recommended engine speed during the break-in period.

Distance traveled	Maximum engine speed
0 ~ 800 km (0 ~ 500 mi)	4 000 r/min (rpm)
800 ~ 1 600 km (500 ~ 1 000 mi)	6 000 r/min (rpm)

NOTE

- *When operating on public roadways, keep maximum speed under traffic law limits.*
- Do not start moving or race the engine immediately after starting it, even if the engine is already warm. Run the engine for two or three minutes at idle speed to give the oil a chance to work up into all the engine parts.

- Do not race the engine while the transmission is in neutral.

⚠ WARNING

New tires are slippery and may cause loss of control and injury. A break-in period of 160 km (100 miles) is necessary to establish normal tire traction. During break-in, avoid sudden and maximum braking and acceleration, and hard cornering.

In addition to the above, at 1 000 km (600 mi) it is extremely important that the owner has the initial maintenance service performed by an authorized Kawasaki dealer.

Starting the Engine

- Check that the engine stop switch is in the  position.

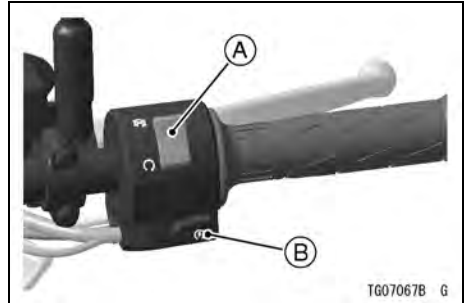

- A. Engine Stop Switch**
- B. Starter Button**

- Turn the ignition key to “ON” position.
- Make sure the transmission is in neutral.

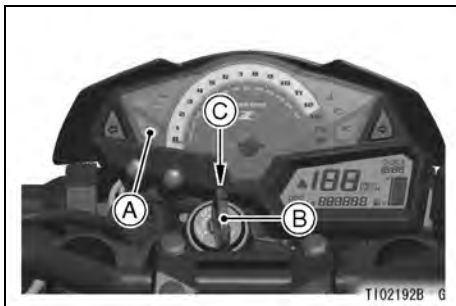

- A. Green Neutral Indicator Light
- B. Ignition Switch
- C. ON position

NOTE

- *The motorcycle is equipped with a vehicle-down sensor which causes the engine to stop automatically if the motorcycle falls down. The engine warning indicator light () blinks when the starter button is pressed*

if the engine cannot be started. After righting the motorcycle, first turn the ignition key to “OFF” position and then back to “ON” position before starting the engine.

- Without holding the throttle grip, push the starter button to start the engine.

NOTICE

Do not operate the starter continuously for more than 5 seconds, or the starter will overheat and the battery power will drop temporarily. Wait 15 seconds between each operation of the starter to let it cool and the battery power recover.

NOTE

- *The motorcycle is equipped with a starter lockout switch. This switch is*

designed so that the engine does not start if the transmission is in gear and the side stand is down. However, the engine can be started if the clutch lever is pulled and the side stand is fully up.

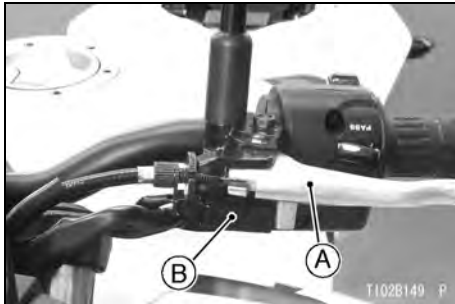

A. Clutch Lever
B. Starter Lockout Switch

NOTICE

Do not let the engine idle longer than five minutes, or engine overheating and damage may occur.

Jump Starting

If your motorcycle battery is “run down,” it should be removed and charged. If this is not practical, a 12 volt booster battery and jumper cables may be used to start the engine.

! DANGER

Battery acid generates hydrogen gas which is flammable and explosive under certain conditions. It is present within a battery at all times, even in a discharged condition. Keep all flames and sparks (cigarettes) away from the battery. Wear eye protection when working with a battery. In the event of battery acid contact with skin, eyes, or clothing, wash the affected areas immediately with water for at least five minutes. Seek medical attention.

Connecting Jumper Cables

- Make sure the ignition key is turned off.

- Remove the side covers and the rider's seat.
- Remove the battery cover. Refer to the Battery section in the MAINTENANCE AND ADJUSTMENT chapter.
- Slide the red cap from the positive (+) terminal.
- Connect a jumper cable from the positive (+) terminal of the booster battery to the positive (+) terminal of the motorcycle battery.

NOTICE

Be careful not to contact the jumper cable slip on the positive battery terminal to the frame, or it will cause a short circuit.

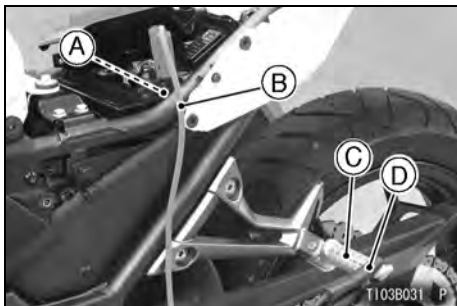

- A. Motorcycle Battery Positive (+) Terminal
- B. From Booster Battery Positive (+) Terminal
- C. Rear Footpeg
- D. From Booster Battery Negative (-) Terminal

- Connect another jumper cable from the negative (-) terminal of the booster battery to your motorcycle rear footpeg or other unpainted metal surface. Do not use the negative (-) terminal of the battery.

! DANGER

Batteries contain sulfuric acid that can cause burns and produce hydrogen gas which is highly explosive. Do not make this last connection at the fuel system or battery. Take care not to touch the positive and negative cables together, and do not lean over the battery when making this last connection. Do not connect to a frozen battery. It could explode. Do not reverse polarity by connecting positive (+) to negative (-), or a battery explosion and serious damage to the electrical system may occur.

- Follow the standard engine starting procedure.

NOTICE

Do not operate the starter continuously for more than 5 seconds or the starter will overheat and the battery power will drop temporarily. Wait 15 seconds between each operation of the starter to let it cool and the battery power recover.

- After the engine has started, disconnect the jumper cables. Disconnect the negative (-) cable from the motorcycle first.
- Reinstall the parts removed.
- Check the cables are correctly routed. Refer to the Battery section in the MAINTENANCE AND ADJUSTMENT chapter.

Moving Off

- Check that the side stand is up.
- Pull in the clutch lever.
- Shift into 1st gear.
- Open the throttle a little, and start to let out the clutch lever very slowly.
- As the clutch starts to engage, open the throttle a little more, giving the engine just enough fuel to keep it from stalling.

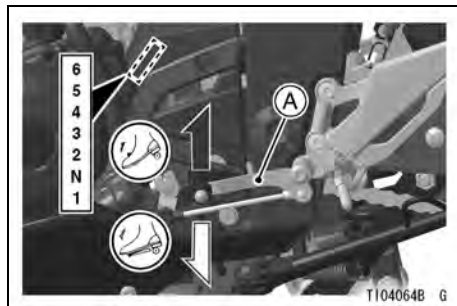
**A. Shift Pedal**

NOTE

- *Other than Indonesia model, the motorcycle is equipped with a side stand switch. This switch is designed so that the engine does not start if the transmission is in gear and the side stand is down.*

Shifting Gears

- Close the throttle while pulling in the clutch lever.
- Shift into the next higher or lower gear.

⚠ WARNING

Downshifting to a lower gear at high speed causes engine rpm to increase excessively, potentially damaging the engine and it may also cause the rear wheel to skid and cause an accident. Downshifting should be done below 5 000 rpm for each gear.

- Open the throttle part way, while releasing the clutch lever.

NOTE

- *The transmission is equipped with a positive neutral finder. When the motorcycle is standing still, the transmission cannot be shifted past neutral from 1st gear. To use the positive neutral finder, shift down to 1st gear, then lift up on the shift pedal while*

72 HOW TO RIDE THE MOTORCYCLE

standing still. The transmission will shift only into neutral.

Braking

- Close the throttle completely, leaving the clutch engaged (except when shifting gears) so that the engine will help slow down the motorcycle.
- Shift down one gear at a time so that you are in 1st gear when you come to a complete stop.
- When stopping, always apply both brakes at the same time. Normally the front brake should be applied a little more than the rear. Shift down or fully disengage the clutch as necessary to keep the engine from stalling.
- Never lock the brakes, or it will cause the tires to skid. When turning a corner, it is better not to brake at all. Reduce your speed before you get into the corner.

- For emergency braking, disregard downshifting, and concentrate on applying the brakes as hard as possible without skidding.

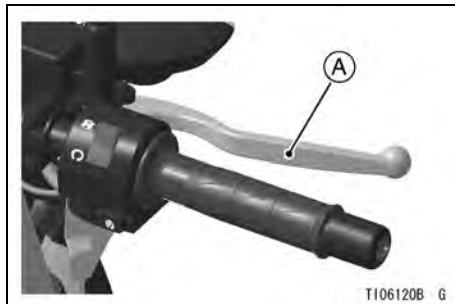

A. Front Brake Lever

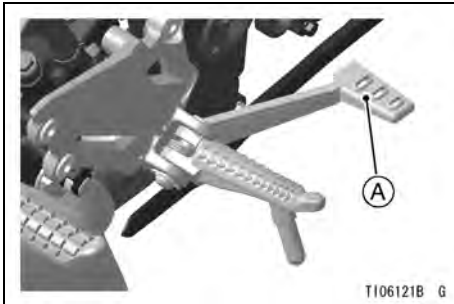

A. Rear Brake Pedal

Stopping the Engine

- Close the throttle completely.
- Shift the transmission into neutral.
- Turn the ignition key to “OFF” position.
- Support the motorcycle on a firm, level surface with the side stand.
- Lock the steering.

NOTE

- *The motorcycle is equipped with a vehicle-down sensor which causes the engine to stop automatically if the motorcycle falls down. The engine warning indicator light () blinks when the starter button is pressed if the engine cannot be started. After righting the motorcycle, first turn the ignition key to “OFF” position and then back to “ON” position before starting the engine.*

Stopping the Motorcycle in an Emergency

Your Kawasaki Motorcycle has been designed and manufactured to provide you optimum safety and convenience. However, in order to fully benefit from Kawasaki’s safety engineering and craftsmanship, it is essential that

74 HOW TO RIDE THE MOTORCYCLE

you, the owner and operator, properly maintain your motorcycle and become thoroughly familiar with its operation. Improper maintenance can create a dangerous situation known as throttle failure. Two of the most common causes of throttle failure are:

1. An improperly serviced or clogged air cleaner may allow dirt and dust to enter the throttle body and stick the throttle open.
2. During removal of the air cleaner, dirt is allowed to enter and jam the fuel injection system.

In an emergency situation such as throttle failure, your vehicle may be stopped by applying the brakes and disengaging the clutch. Once this stopping procedure is initiated, the engine stop switch may be used to stop

the engine. If the engine stop switch is used, turn off the ignition switch after stopping the motorcycle.

Parking

WARNING

Operating or parking the vehicle near flammable materials can cause a fire, and can result in property damage or severe personal injury.

Do not idle or park your vehicle in an area where tall or dry vegetation, or other flammable materials could come into contact with the muffler or exhaust pipe.

⚠ WARNING

The engine and exhaust system get extremely hot during normal operation and can cause serious burns.

Never touch a hot engine, exhaust pipe, or muffler during operation or after stopping the engine.

- Shift the transmission into neutral and turn the ignition key to “OFF” position.
- Support the motorcycle on a firm, level surface with the side stand.

NOTICE

Do not park on a soft or steeply inclined surface, or the motorcycle may fall over.

- If parking inside a garage or other structure, be sure it is well ventilated and the motorcycle is not close to any source of flame or sparks; this includes any appliance with a pilot light.

⚠ WARNING

Gasoline is extremely flammable and can be explosive under certain conditions, creating the potential for serious burns. Turn the ignition switch off. Do not smoke. Make sure the area is well ventilated and free from any source of flame or sparks; this includes any appliance with a pilot light.

- Lock the steering to help prevent theft.

MAINTENANCE AND ADJUSTMENT

The maintenance and adjustments outlined in this chapter must be carried out in accordance with the Daily Safety Checks and Periodic Maintenance to keep the motorcycle in good running condition and to reduce air pollution. **The initial maintenance is vitally important and must not be neglected.**

WARNING

Failure to perform these checks or to correct a problem before operation may result in serious damage or an accident. Always perform daily safety checks before operation.

With a basic knowledge of mechanics and the proper use of tools, you should be able to carry out many of the maintenance items described in this chapter. If you lack proper experience or doubt your ability, all adjustments, maintenance, and repair work should be completed by a qualified technician.

Please note that Kawasaki cannot assume any responsibility for damage resulting from incorrect or improper adjustment made by the owner.

 **DANGER**

Exhaust gas contains carbon monoxide, a colorless, odorless poisonous gas. Inhaling carbon monoxide can cause serious brain injury or death. **DO NOT** run the engine in enclosed areas. Operate only in a well-ventilated area.

 **WARNING**

The cooling fan spins at high speed and can cause serious injuries. Keep your hands and clothing away from the cooling fan blades at all times.

NOTE

- *If a torque wrench is not available, the maintenance items which require a specific torque value should be serviced by an authorized Kawasaki dealer.*

Daily Safety Checks

Check the following items each day before you ride. The time required is minimal, and habitual performance of these checks will help ensure you a safe, reliable ride.

If any irregularities are found during these checks, refer to the MAINTENANCE AND ADJUSTMENT chapter or see your dealer for the action required to return the motorcycle to a safe operating condition.

Operation	See Page
Fuel Adequate supply in tank, no leaks	–
Engine Oil Oil level between level lines	86
Tires Air pressure (when cold), install the air valve cap Tire wear	114 115
Drive Chain Slack	102

Operation	See Page
Lubricate if dry	102
Bolts, nuts and fasteners	
Check for loose and/or missing bolts, nuts and fasteners	–
Steering	
Action smooth but not loose from lock to lock	–
No binding of control cables	–
Brakes	
Brake pad wear	108
Brake fluid level	107
No brake fluid leakage	–
Throttle	
Throttle grip play	97
Clutch	
Clutch lever play	100
Clutch lever operates smoothly	–

80 MAINTENANCE AND ADJUSTMENT

Operation	See Page
Coolant	
No coolant leakage	–
Coolant level between level lines (when engine is cold)	89
Electrical equipment	
All lights (head, tail/brake, turn signal, warning/indicator) and horn work	–
Engine stop switch	
Stops engine	–
Side stand	
Return to its fully up position by spring tension	–
Return spring not weak or not damaged	–
Rear view mirrors	
Rear view sight	–

Periodic Maintenance

- *A: Service at number of years shown or indicated odometer reading intervals, whichever comes first.
- *B: For higher odometer readings, repeat at the frequency interval established here.
- *C: Service more frequently when operating in severe conditions: dusty, wet, muddy, high speed, or frequent starting/stopping.
- *D: Thailand model only

: Inspection

: Dealer Inspection



: Change or Replace

: Dealer Change or Replace

: Lubrication

: Dealer Lubrication

82 MAINTENANCE AND ADJUSTMENT

Items	year (*A)	Odometer Reading (*B) × 1 000 km (× 1 000 mile)					See Page
		1 (0.6)	6 (3.8)	12 (7.6)	18 (11.4)	24 (15.2)	
Air cleaner element (*C)	 : 2			Q		Q	93
Idle speed		Q		Q		Q	99
Throttle control system (play, smooth return, no drag)	Q:1	Q		Q		Q	97
Engine vacuum synchronization				Q		Q	–
Fuel system	Q:1	Q		Q		Q	–
Fuel hose	 :5						–
Evaporative emission control system (*D)		Q	Q	Q	Q	Q	–
Coolant level		Q		Q		Q	89
Cooling system	Q:1	Q		Q		Q	–

Items	year (*A)	Odometer Reading (*B) × 1 000 km (× 1 000 mile)					See Page
		1 (0.6)	6 (3.8)	12 (7.6)	18 (11.4)	24 (15.2)	
Coolant, water hoses and O-rings	:3	: every 36 000 km (22 500 mile)					–
Valve clearance							–
Air suction system							–
Clutch operation (play, engagement, disengagement)							100
Engine oil (*C) and Oil filter	:1						87
Tire air pressure	:1						114
Wheels and tires	:1						114
Wheel bearing damage	:1						–
Drive chain lubrication condition (*C)		: every 600 km (400 mile)					102

84 MAINTENANCE AND ADJUSTMENT

Items	year (*A)	Odometer Reading (*B) × 1 000 km (× 1 000 mile)					See Page
		1 (0.6)	6 (3.8)	12 (7.6)	18 (11.4)	24 (15.2)	
Drive chain slack (*C)		🔍: every 1 000 km (600 mile)					102
Drive chain wear (*C)				🔍		🔍	–
Drive chain guide wear				🔍		🔍	–
Brake system	🔍:1	🔍	🔍	🔍	🔍	🔍	–
Brake operation (effectiveness, play, no drag)	🔍:1	🔍	🔍	🔍	🔍	🔍	106
Brake fluid level	🔍:0.5	🔍	🔍	🔍	🔍	🔍	107
Brake fluid (front and rear)	🔄:2					🔄	–
Brake hose/rubber parts of brake master cylinder and caliper	🔄:4	🔄: every 48 000 km (30 000 mile)					–
Brake pad wear (*C)			🔍	🔍	🔍	🔍	108

Items	year (*A)	Odometer Reading (*B) × 1 000 km (× 1 000 mile)					See Page
		1 (0.6)	6 (3.8)	12 (7.6)	18 (11.4)	24 (15.2)	
Brake light switch operation		Q	Q	Q	Q	Q	109
Suspension system	Q: 1			Q		Q	—
Lubrication of rear suspension						↗	—
Steering play	Q:1	Q		Q		Q	—
Steering stem bearings	↗:2					↗	—
Electrical system	Q:1			Q		Q	—
Spark plugs				↻		↻	—
Chassis parts	↗:1			↗		↗	—
Condition of bolts, nuts and fasteners		Q		Q		Q	—

Engine Oil

Oil Level Inspection

- If the engine is cold, start the engine and run it for several minutes at idle speed.
- Stop the engine, then wait several minutes until the oil settles.

NOTICE

Racing the engine before the oil reaches every part can cause engine seizure.

- Check the engine oil level through the oil level inspection window. With the motorcycle held level, the oil level should come up between the upper and lower level lines next to the oil level inspection window.

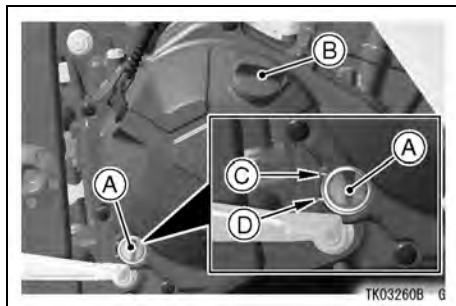

- A. Oil Level Inspection Window
- B. Oil Filler Cap
- C. Upper Level Line
- D. Lower Level Line

- If the oil level is too high, remove the excess oil through the oil filler opening using a syringe or some other suitable device.
- If the oil level is too low, add oil to reach the correct level. Use the same type and brand of oil that is already in the engine.

Oil and/or Oil Filter Change

- The oil change and oil filter replacement should be done by an authorized Kawasaki dealer.

⚠ WARNING

Engine oil is a toxic substance. Dispose of used oil properly. Contact your local authorities for approved disposal methods or possible recycling.

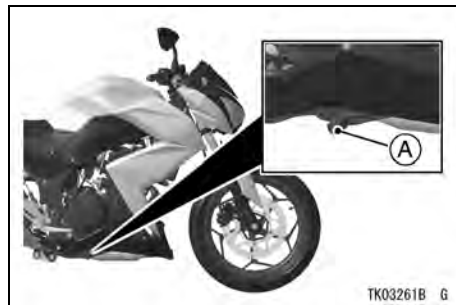

A. Engine Oil Drain Bolt

Tightening Torque

Engine Oil Drain Bolt:

19.6 N·m (2.00 kgf·m, 14.5 ft·lb)

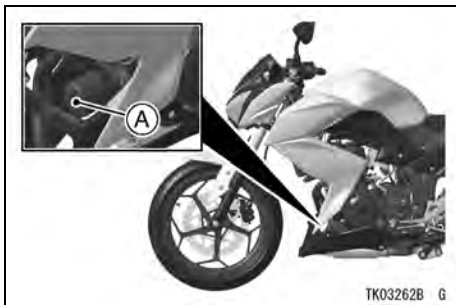

A. Oil Filter

Tightening Torque

Oil Filter:

17.5 N·m (1.78 kgf·m, 12.9 ft·lb)

Recommended Engine Oil

Type: API SG, SH, SJ, SL, or SM with JASO MA, MA1 or MA2

Viscosity: SAE 10W-40

NOTE

- Do not add any chemical additive to the oil. Oils fulfilling the above requirements are fully formulated and provide adequate lubrication for both the engine and the clutch.

Engine Oil Capacity

Capacity: 2.0 L (2.1 US qt)

[when filter is not removed]

2.2 L (2.3 US qt)

[when filter is removed]

Although 10W-40 engine oil is the recommended oil for most conditions, the oil viscosity may need to be changed to accommodate atmospheric conditions in your riding area.

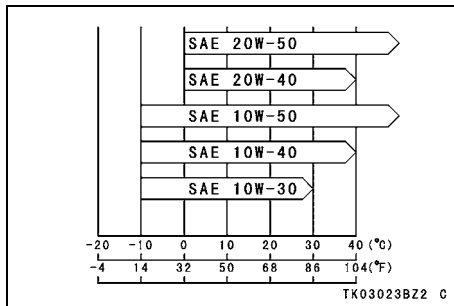

Coolant

Coolant Level Inspection

- Position the motorcycle so that it is perpendicular to the ground.
- Check the coolant level through the coolant level gauge on the reserve tank located to the right of the engine. The coolant level should be between the F (Full) and L (Low) level lines.

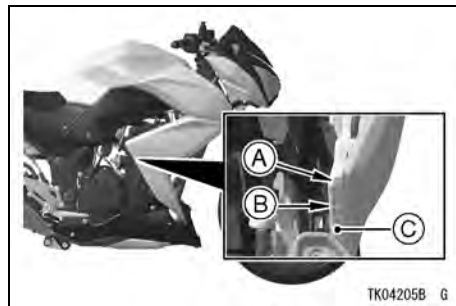

- A. F (Full) Level Line
- B. L (Low) Level Line
- C. Reserve Tank

NOTE

- Check the level when the engine is cold (room or atmospheric temperature).
- If the amount of coolant is insufficient, add coolant into the reserve tank.

90 MAINTENANCE AND ADJUSTMENT

Coolant Filling

- Remove the right side cover. Refer to the Seat section in the GENERAL INFORMATION chapter.
- Remove the screw, bolt and collar on the right knee grip cover.
- Clear the projections and tabs on the right knee grip cover.
- Open the clamp to free the clutch cable, and remove the right knee grip cover.

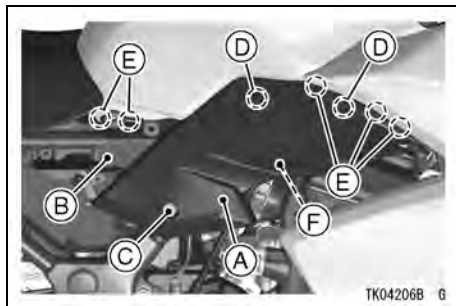

- A. Right Knee Grip Cover**
- B. Screw**
- C. Bolt and Collar**
- D. Projections**
- E. Tabs**
- F. Clamp**

- Remove the cap from the reserve tank and add coolant through the filler opening to the F (Full) level line.

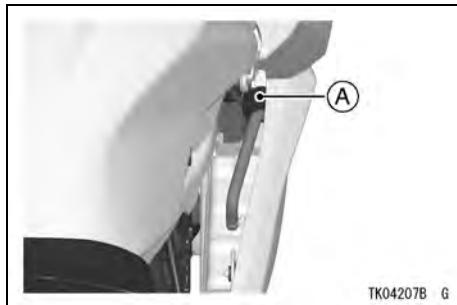

A. Reserve Tank Cap

NOTE

- *In an emergency you can add water alone to the coolant reserve tank, however it must be returned to the correct mixture ratio by the addition of antifreeze concentrate as soon as possible.*

NOTICE

If coolant must be added often, or the reserve tank completely runs dry, there is probably leakage in the system. Have the cooling system inspected by your authorized Kawasaki dealer.

- Install the reserve tank cap.
- Hold the clutch cable with the clamp.
- Insert the tabs on the right knee grip cover into the slots.
- Insert the projections on the right knee grip cover into the holes.

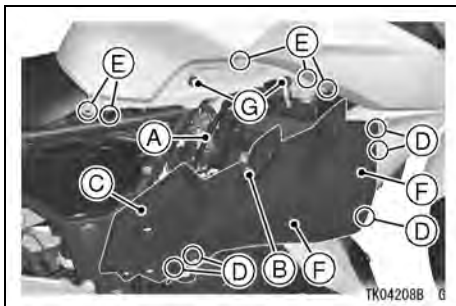

- A. Clutch Cable
- B. Clamp
- C. Right Knee Grip Cover
- D. Tabs
- E. Slots
- F. Projections
- G. Holes

Coolant Change

Have the coolant changed by an authorized Kawasaki dealer.

Coolant Requirement

⚠ WARNING

Coolant containing corrosion inhibitors for aluminum engines and radiators include harmful chemicals for human body. Drinking coolant can result in serious injury or death. Use coolant in accordance with the instructions of the manufacturer.

Use a permanent type of antifreeze (soft water and ethylene glycol plus corrosion and rust inhibitor chemicals for aluminum engines and radiators) in the cooling system. On the mixture ratio of coolant, choose the suitable one referring to the relation between freezing point and strength directed on the container.

NOTICE

If hard water is used in the system, it causes scale accumulation in the water passages, and considerably reduces the efficiency of the cooling system.

NOTE

- A permanent type of antifreeze is installed in the cooling system when shipped. It is mixed at 50% and has the freezing point of -35°C (-31°F).

Air Cleaner**Element Removal**

- Remove the right side cover.

- Unscrew the air cleaner element cap mounting screws, then remove the air cleaner element cap.

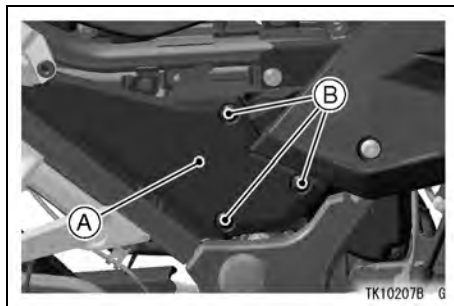

- A. Air Cleaner Element Cap
- B. Mounting Screws

- Pull out the air cleaner element from the air cleaner housing.

94 MAINTENANCE AND ADJUSTMENT

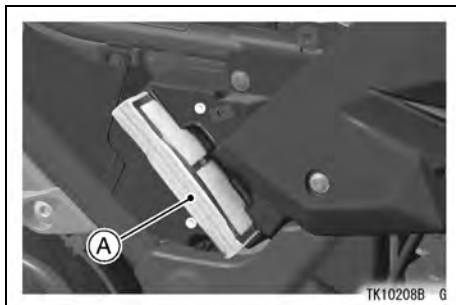

A. Element

- Remove the element from the frame.

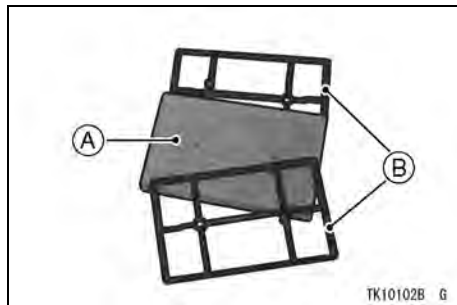

A. Element

B. Frame

- Put a clean, lint-free towel into the air cleaner housing to keep dirt or other foreign material from entering.
- Inspect the element material for damage. If any part of the element is damaged, the element must be replaced.

⚠ WARNING

If dirt or dust is allowed to pass through into the throttle body assembly, the throttle may become stuck, possibly causing accident. Be sure to keep the dust from entering during cleaning.

NOTICE

If dirt gets through into the engine, excessive engine wear and possibly engine damage will occur.

- The element and removed part installation is performed in the reverse order of removal.

Element Cleaning

- Clean the element in a bath of a high flash-point solvent.
- Squeeze it dry in a clean towel. Do not wring the element or blow it dry; the element can be damaged.
- Check all the parts of the element for visible damage.
- If any of the parts of the element are damaged, replace them.
- After cleaning, saturate the element with a high-quality foam-air-filter oil, squeeze out the excess, then wrap it in a clean towel and squeeze it as dry as possible.
- Be careful not to tear the element.

⚠ WARNING

Gasoline and low flash-point solvents are extremely flammable and may explode, causing severe burns. Do not use gasoline or a low flash-point solvent to clean the element. Clean the element in a well-ventilated area. Be sure there are no sparks or flame in the work area, including any appliance with a pilot light.

Oil Draining

- Inspect the transparent drain cap located at the left lower end of the air cleaner housing to see if any oil has run down.

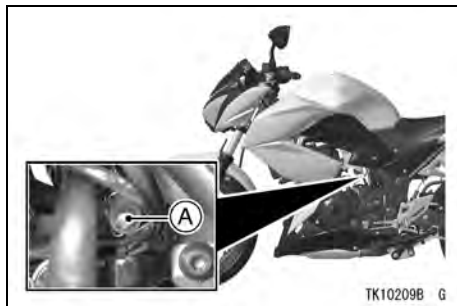
**A. Drain Cap**

- If there is any oil in the drain cap, remove the cap from the lower end of the air cleaner housing and drain the oil.

⚠ WARNING

Oil on tires will make them slippery and can cause an accident and injury. Be sure to install the drain cap to the air cleaner housing after draining.

Throttle Control System

Throttle Grip

Throttle Grip Free Play Inspection

- Check that the throttle grip moves smoothly from full open to close, and the throttle closes quickly and completely by the return spring in all steering positions.
- If the throttle grip does not return properly, have the throttle control system checked by an authorized Kawasaki dealer.

- Check the throttle grip free play by turning back and forth.

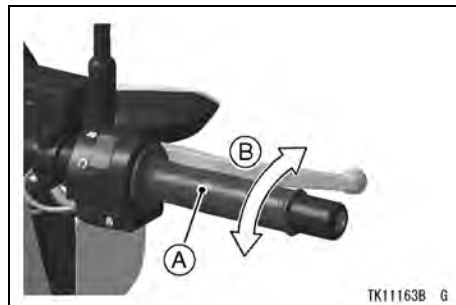

- A. Throttle Grip
- B. Throttle Grip Play

Throttle Grip Play

2 ~ 3 mm (0.08 ~ 0.12 in.)

- If there is improper play, adjust it.

98 MAINTENANCE AND ADJUSTMENT

Throttle Grip Free Play Adjustment

- Loosen the locknut at the throttle grip, and turn the adjuster until the proper amount of throttle grip play is obtained.

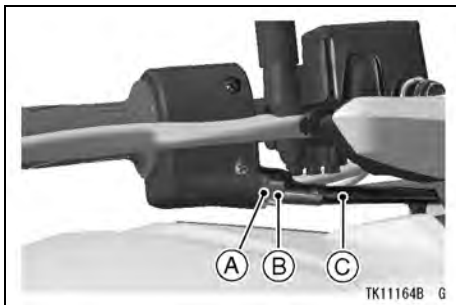

- A. Locknut
- B. Adjuster
- C. Throttle Cable (Accelerator Cable)

- If the throttle cables cannot be adjusted with the adjuster at the upper

end of the throttle cable, further adjustment of the throttle cables should be done by an authorized Kawasaki dealer.

- With the engine idling, turn the handlebars to each side. If handlebars movement changes the idle speed, the throttle cables may be improperly adjusted or incorrectly routed, or they may be damaged. Be sure to correct any of these conditions before idling.

⚠ WARNING

Operation with improperly adjusted, incorrectly routed, or damaged cables could result in an unsafe riding condition. Be sure the control cables are adjusted and routed correctly, and are free from damage.

Idle Speed

Idle Speed Adjustment

- Start the engine, and warm it up thoroughly.
- Adjust the idle speed by turning the idle adjusting screw.

Idle Speed

1 250 ~ 1 350 r/min (rpm)

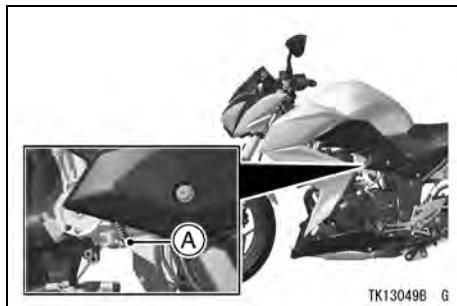

A. Idle Adjusting Screw

- Open and close the throttle a few times to make sure that the idle speed does not change. Readjust if necessary.
- With the engine idling, turn the handlebars to each side. If handlebars movement changes the idle speed, the throttle cables may be improperly adjusted or incorrectly routed, or they may be damaged. Be sure to correct any of these conditions before riding.

⚠ WARNING

Operation with damaged cables could result in an unsafe riding condition. Replace damaged control cables before operation.

Clutch

Clutch Operation Inspection

- Check that the clutch lever operates properly and that the inner cable slides smoothly. If there is any irregularity, have the clutch cable checked by an authorized Kawasaki dealer.
- Check the clutch lever play as shown.

Clutch Lever Play

2 ~ 3 mm (0.08 ~ 0.12 in.)

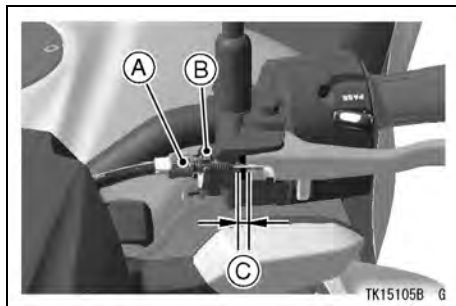

- A. Adjuster
- B. Locknut
- C. Clutch Lever Play

- If the play is incorrect, adjust the lever play as follows.

Clutch Cable Free Play Adjustment

- Loosen the locknut at the clutch lever.
- Turn the adjuster so that the clutch lever will have the specified free play.

WARNING

Too much cable play can prevent clutch disengagement and cause an accident resulting in serious injury or death. When adjusting the clutch or replacing the cable, be sure the upper end of the clutch outer cable is fully seated in its fitting, or it could slip into place later, creating enough cable play to prevent clutch disengagement.

- Tighten the locknut.
- If it cannot be done, use the mounting nuts at the lower end of the cable.

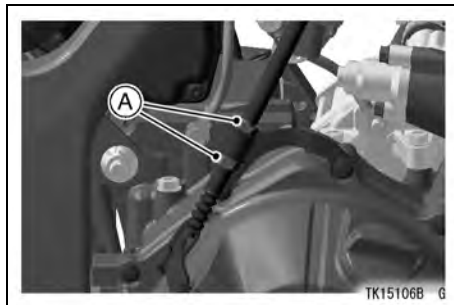

A. Nuts

NOTE

- *After the adjustment is made, start the engine and check that the clutch does not slip and that it releases properly.*

Drive Chain

Drive Chain Lubrication

Lubrication is necessary after riding through rain or on wet roads, or any time that the chain appears dry.

Use a lubricant for sealed chains to prevent deterioration of chain seals. If the chain is especially dirty, clean it using a cleaner for sealed chains following the instructions supplied by the chain cleaner manufacturer.

- Apply lubricant to the sides of the rollers so that it will penetrate to the rollers and bushings. Apply lubricant to the seals so that the seals will be coated with lubricant. Wipe off any excess lubricant.

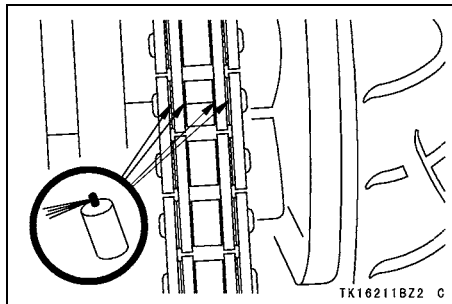

- Wipe off any lubricant that gets on the tire surface.

Drive Chain Slack Inspection

- Set the motorcycle up on its side stand.
- Clean the chain if it is dirty, and lubricate it if it appears dry.
- Rotate the rear wheel to find the position where the chain is tightest, and measure the maximum chain slack by pulling up and pushing down the

chain midway between the engine sprocket and rear wheel sprocket.

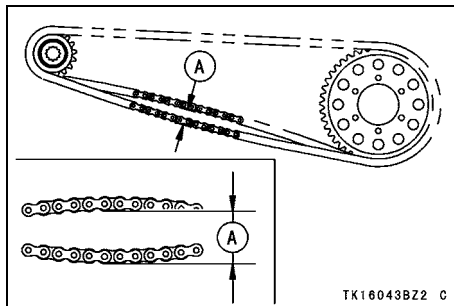

A. Chain Slack

- If the drive chain is too tight or too loose, adjust it so that the chain slack is within the standard value.

Drive Chain Slack

Standard: 20 ~ 30 mm (0.8 ~ 1.2 in.)

Drive Chain Slack Adjustment

- Loosen the left and right chain adjuster locknuts.
- Remove the cotter pin, and loosen the axle nut.

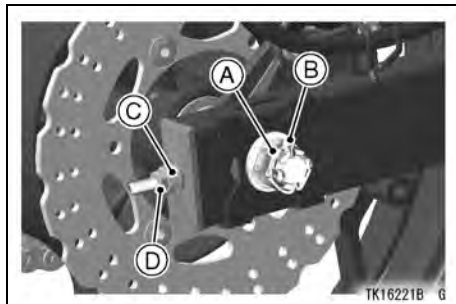

- A. Axle Nut
- B. Cotter Pin
- C. Adjusting Nut
- D. Locknut

- If the chain is too loose, turn in the left and right chain adjusting nuts evenly.

104 MAINTENANCE AND ADJUSTMENT

- If the chain is too tight, turn out the left and right chain adjusting nuts evenly.
- Turn out both chain adjusting nuts evenly until the drive chain has the correct amount of slack. To keep the chain and wheel properly aligned, the notch on the left wheel alignment indicator should align with the same swingarm mark that the right indicator notch aligns with.

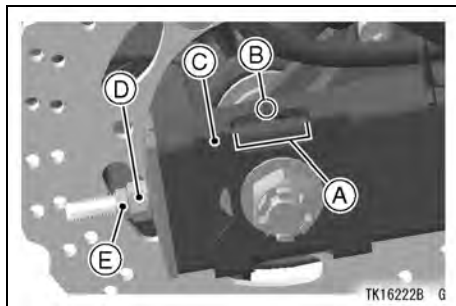

- A. Marks
- B. Notch
- C. Indicator
- D. Adjusting Nut
- E. Locknut

NOTE

- *Wheel alignment can also be checked using the straightedge or string method.*

⚠ WARNING

Misalignment of the wheel will result in abnormal wear, and may result in an unsafe riding condition. Align the rear wheel using the marks on the swingarm or measuring the distance between the center of the axle and swingarm pivot.

- Tighten both chain adjuster locknuts.
- Tighten the axle nut to the specified torque.

Tightening Torque

Axle Nut: 98 N·m (10 kgf·m, 72 ft·lb)

NOTE

- If a torque wrench is not available, this item should be serviced by an authorized Kawasaki dealer.

- Rotate the wheel, measure the chain slack again at the tightest position, and readjust if necessary.
- Install a new cotter pin through the axle nut and axle, and spread its ends.

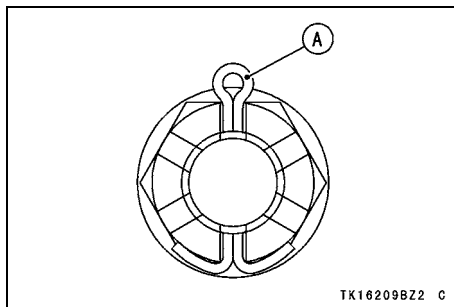

A. Cotter Pin

NOTE

- When inserting the cotter pin, if the slots in the nut do not align with the cotter pin hole in the axle shaft,

106 MAINTENANCE AND ADJUSTMENT

tighten the nut clockwise up to the next alignment.

- *It should be within 30 degrees.*
- *Loosen once and tighten again when the slot goes past the nearest hole.*

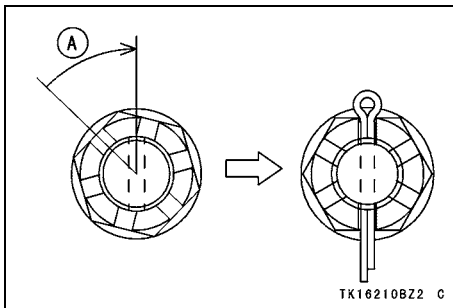

A. Turn Clockwise

⚠ WARNING

A loose axle nut can lead to an accident resulting in serious injury or death. Tighten the axle nut to the proper torque and install a new cotter pin.

- Check the rear brake (see the Brakes section).

Brakes

Brake Operation Inspection

- If you feel there is something wrong when applying the brakes, have the brake system checked by an authorized Kawasaki dealer immediately.

⚠ WARNING

Air in the brake lines diminish braking performance and can cause an accident resulting in injury or death. If the brake lever or pedal feels mushy when it is applied, there might be air in the brake lines or the brake may be defective. Have the brake checked immediately by an authorized Kawasaki dealer.

Brake Fluid Level Inspection

- With the front brake fluid reservoir held horizontal, the brake fluid level must be above the lower level line.

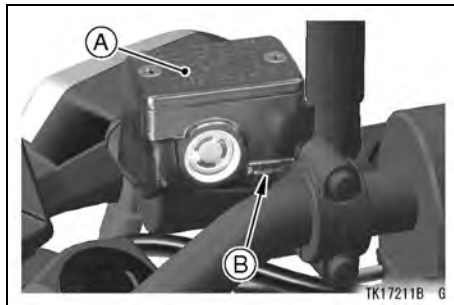

- A. Front Brake Fluid Reservoir
- B. Lower Level Line

- With the rear brake fluid reservoir held horizontal, the brake fluid level must be kept between the upper and lower level lines.

108 MAINTENANCE AND ADJUSTMENT

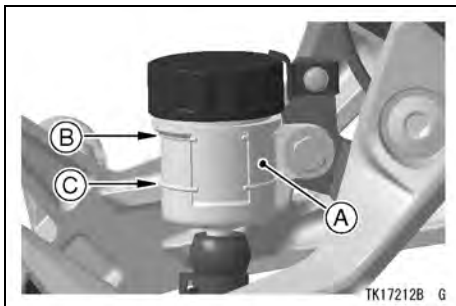

- A. Rear Brake Fluid Reservoir
- B. Upper Level Line
- C. Lower Level Line

- If the fluid level is lower than the lower level line it may indicate that the fluid is leaking. In this case, have the brake system inspected by an authorized Kawasaki dealer.

Brake Pad Wear Inspection

Inspect the brakes for wear. For each front and rear disc brake caliper, if the

thickness of either pad lining is less than below table, replace both pads in the caliper as a set. Pad replacement should be done by an authorized Kawasaki dealer.

Lining Thickness Service Limit

Front	1.5 mm (0.06 in.)
Rear	1.5 mm (0.06 in.)

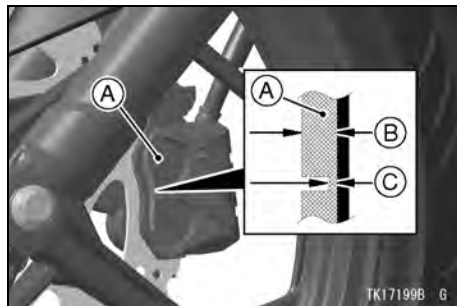

- A. Front Brake Pads
- B. Lining Thickness
- C. Service Limit

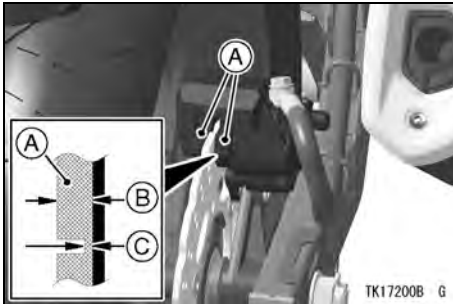

- A. Rear Brake Pads
- B. Lining Thickness
- C. Service Limit

Brake Light Switches

Brake Light Switch Inspection

- Turn the ignition switch on.
- The brake light should go on when the front brake is applied.

- If it does not, ask your authorized Kawasaki dealer to inspect the front brake light switch.
- Check the operation of the rear brake light switch by depressing the brake pedal. The brake light should go on after the proper pedal travel.

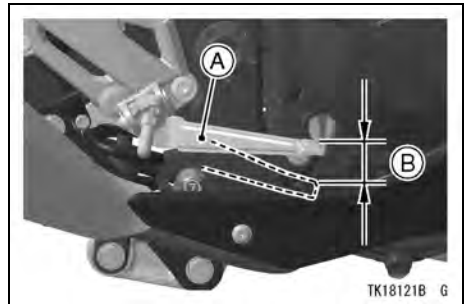

- A. Brake Pedal
- B. 10 mm (0.4 in.)

- If the light does not come on, adjust the rear brake light switch.

110 MAINTENANCE AND ADJUSTMENT

Brake Pedal Travel

10 mm (0.4 in.)

Brake Light Switch Adjustment

- To adjust the rear brake light switch, move the switch up or down by turning the adjusting nut.

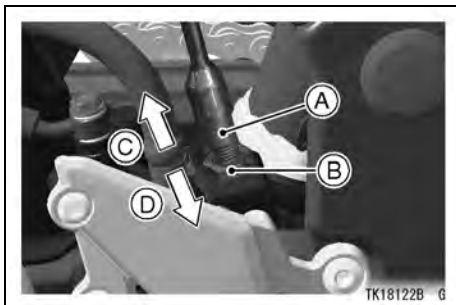

- A. Rear Brake Light Switch
- B. Adjusting Nut
- C. Lights sooner
- D. Lights later

NOTICE

To avoid damaging the electrical connections inside the switch, be sure that the switch body does not turn during adjustment.

Suspension System

Rear Shock Absorber

Spring Preload Adjustment

The spring preload adjuster on the rear shock absorber has 5 positions.

Standard

2nd position

- Remove the bolts to take off the chain cover.

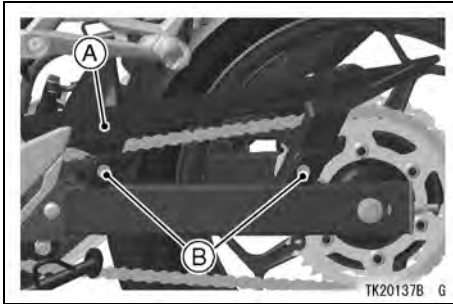

A. Chain Cover
B. Bolts

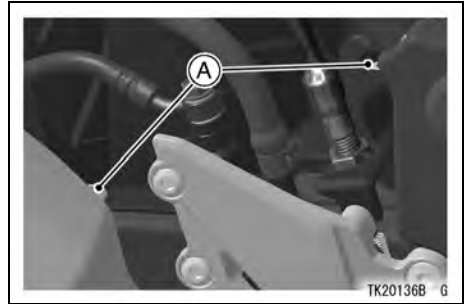

A. Bolts

- Turn the adjuster counterclockwise to increase spring preload and stiffen the suspension.
- Turn the adjuster clockwise to decrease preload and soften the suspension.

112 MAINTENANCE AND ADJUSTMENT

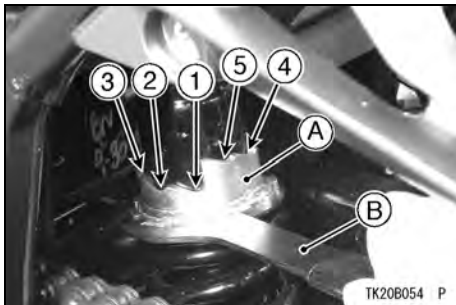

A. Spring Preload Adjuster

B. Wrench

- Install the chain cover in the reverse order of removal.

Setting Table

Rear Shock Absorber Spring Preload Setting

	Softest setting limit	Standard	Hardest setting limit
Adjuster Position	1st	2nd	5th
Spring Action	Weak	←→	Strong
Setting	Soft	←→	Hard
Load	Light	←→	Heavy
Road	Good	←→	Bad
Speed	Low	←→	High

Wheels

Tire Pressure Inspection

- Remove the air valve cap.
- Check the tire pressure often, using an accurate gauge.
- Make sure to install the air valve cap securely.

NOTE

- *Measure the tire pressure when the tires are cold (that is, when the motorcycle has not been ridden more than a mile during the past 3 hours).*
- *Tire pressure is affected by changes in ambient temperature and altitude, and so the tire pressure should be checked and adjusted when your riding involves wide variations in temperature or altitude.*

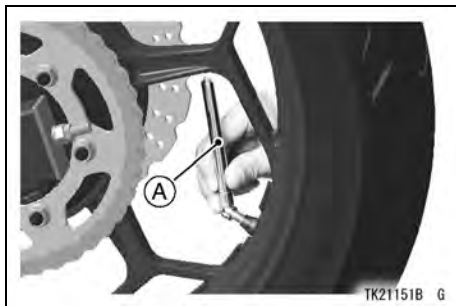

A. Tire Pressure Gauge

Tire Air Pressure (when cold)

Front	200 kPa (2.00 kgf/cm ² , 28 psi)
Rear	225 kPa (2.25 kgf/cm ² , 32 psi)

Tire Wear, Damage

As the tire tread wears down, the tire becomes more susceptible to puncture and failure. An accepted estimate is that 90% of all tire failures occur during the last 10% of tread life (90% worn).

So it is false economy and unsafe to use the tires until they are bald.

Tire Wear Inspection

- Measure the depth of the tread with a depth gauge, and replace any tire that has worn down to the minimum allowable tread depth.

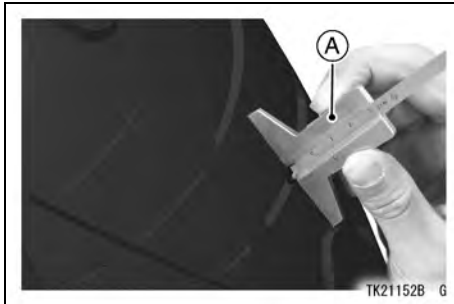

A. Tire Depth Gauge

Minimum Tread Depth

Front	—	1 mm (0.04 in.)
Rear	Under 130 km/h (80 mph)	2 mm (0.08 in.)
	Over 130 km/h (80 mph)	3 mm (0.12 in.)

- Visually inspect the tire for cracks and cuts, replacing the tire in case of bad damage. Swelling or high spots indicate internal damage, requiring tire replacement.

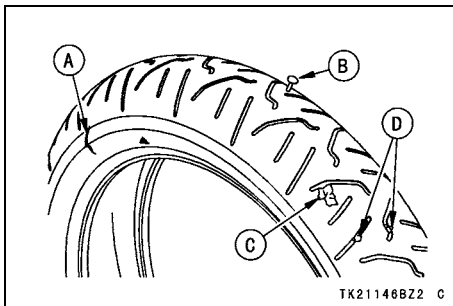

- A. Crack or Cut
- B. Nail
- C. Swelling or High Spot
- D. Stone

- Remove any imbedded stones or other foreign particles from the tread.

NOTE

- *Have the wheel balance inspected whenever a new tire is installed.*

⚠ WARNING

Tires that have been punctured and repaired do not have the same capabilities as undamaged tires and can suddenly fail, causing an accident resulting in serious injury or death. Replace damaged tires as soon as possible. To ensure safe handling and stability, use only the recommended standard tires for replacement, inflated to the standard pressure. If it is necessary to ride on a repaired tire, do not exceed 100 km/h (60 mph) until the tire is replaced.

NOTE

- *Most countries may have their own regulations requiring a minimum tire tread depth; be sure to follow them.*

- *When operating on public roadways, keep maximum speed under traffic law limits.*

Standard Tire (Tubeless)

Front	Make, Type: IRC, ROAD WINNER RX-01F TL Size: 110/70-17M/C 54S
Rear	Make, Type: IRC, ROAD WINNER RX-01R ZD TL Size: 140/70-17M/C 66S

WARNING

Mixing tire brands and types can adversely affect handling and cause an accident resulting in injury or death. Always use the same manufacturer's tires on both front and rear wheels.

WARNING

New tires are slippery and may cause loss of control and injury. A break-in period of 160 km (100 miles) is necessary to establish normal tire traction. During break-in, avoid sudden and maximum braking and acceleration, and hard cornering.

Battery

The battery installed in this motorcycle is a sealed type, so it is not necessary to check the battery electrolyte level or add distilled water.

NOTICE

Never remove the sealing strip, or the battery can be damaged. Do not install a conventional battery in this motorcycle, or the electrical system cannot work properly.

Battery Maintenance

It is the owner's responsibility to keep the battery fully charged. Failure to do so can lead to battery failure and leave you stranded.

If you are riding your vehicle infrequently, inspect the battery voltage

weekly using a voltmeter. If it drops below 12.6 volts, the battery should be charged using an appropriate charger (check with your Kawasaki dealer). If you will not be using the motorcycle for longer than two weeks, the battery should be charged using an appropriate charger. Do not use an automotive-type quick charger that may overcharge the battery and damage it.

NOTE

○ *Leaving the battery connected causes the electrical components (clock etc) to make the battery discharged, resulting the over discharge of the battery. In this case, the repair or replacement of the battery is not included in the warranty. If you do*

not drive for four weeks or more, disconnect the battery from the vehicle.

Kawasaki-recommended chargers are:

Battery Mate 150-9
OptiMate 4
Yuasa MB-2040/2060
Christie C10122S

If the above chargers are not available, use equivalent one.

For more details, ask your Kawasaki dealer.

Battery Charging

- Charge the battery following the instructions of your battery charger.
- The charger will keep the battery fully charged until you are ready to re-install the battery in the motorcycle (see Battery Installation).

! DANGER

Battery acid generates hydrogen gas which is flammable and explosive under certain conditions. It is present within a battery at all times, even in a discharged condition. Keep all flames and sparks (cigarettes) away from the battery. Wear eye protection when working with a battery. In the event of battery acid contact with skin, eyes, or clothing, wash the affected areas immediately with water for at least five minutes. Seek medical attention.

Battery Removal

- Make sure the ignition switch is turned off.
- Remove the left and right side covers and the rider's seat. Refer to the

120 MAINTENANCE AND ADJUSTMENT

Seats section in the GENERAL INFORMATION chapter.

- Unscrew the cover screw and pull up the battery cover with the relay assy.

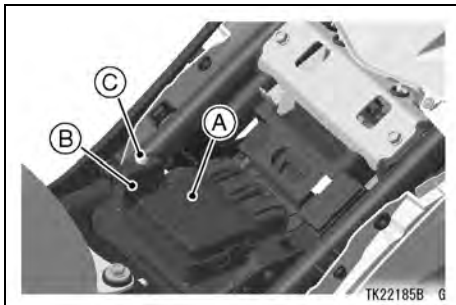

- A. Relay Assy
- B. Battery Cover
- C. Cover Screw

- Disconnect the cables from the battery, first from the (-) terminal and then the (+) terminal.

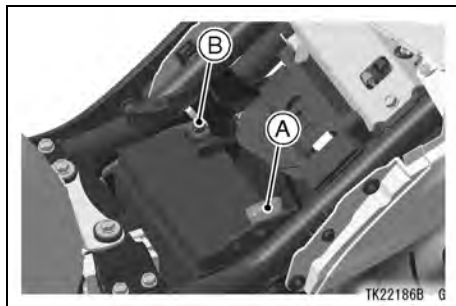

- A. (+) Terminal
- B. (-) Terminal

- Take the battery out of the case.
- Clean the battery using a solution of baking soda and water. Be sure that the cable connections are clean.

Battery Installation

- Run the capped cable above the main harness at the main fuse side.
- Run the capped cable under the main harness at the terminal side.

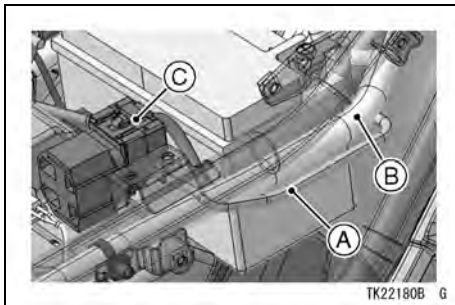

- A. Capped Cable
- B. Main Harness
- C. Main Fuse

- Place the battery in the battery case.
- Connect the capped cable to the (+) terminal, and then connect the black cable to the (-) terminal.

NOTICE

Installing the (-) cable to the (+) terminal of the battery or the (+) cable to the (-) terminal of the battery can seriously damage the electrical system.

- Put a light coat of grease on the terminals to prevent corrosion.
- Cover the (+) terminal with its protective cap.
- Reinstall the parts removed.

NOTE

- *When installing the battery cover, insert tab of the battery cover into hole of the frame and tighten the screw.*

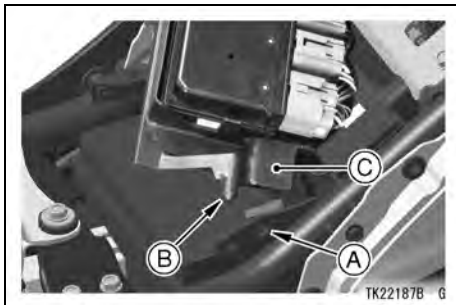

- A. Hole
- B. Tab
- C. Battery Cover

Headlight

Headlight aiming should be done by an authorized Kawasaki dealer.

Horizontal Adjustment

The headlight beam is adjustable horizontally. If not properly adjusted

horizontally, the beam will point to one side rather than straight ahead.

- Turn the horizontal adjuster in or out until the beam points straight ahead.

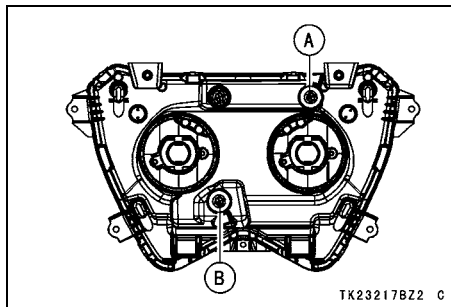

- A. Horizontal Adjuster
- B. Vertical Adjuster

Vertical Adjustment

The headlight beam is adjustable vertically. If adjusted too low, neither low nor high beam will illuminate the road far enough ahead. If adjusted too high,

the high beam will fail to illuminate the road close ahead, and the low beam will blind oncoming drivers.

- Turn the vertical adjuster in or out to adjust the headlight vertically.

NOTE

- *On high beam, the brightest point should be slightly below horizontal with the motorcycle on its wheels and the rider seated. Adjust the headlight to the proper angle according to local regulations.*



Fuses

Fuses are arranged in the fuse box located under the rider's seat. The main fuse is mounted on the starter relay located under the rider's seat. If a fuse fails during operation, inspect the electrical system to determine the cause, and then replace it with a new fuse of proper amperage.

If the fuse fails repeatedly, there is something wrong with the electrical

124 MAINTENANCE AND ADJUSTMENT

system. Have the motorcycle checked by an authorized Kawasaki dealer.

The main fuse removal should be done by an authorized Kawasaki dealer.

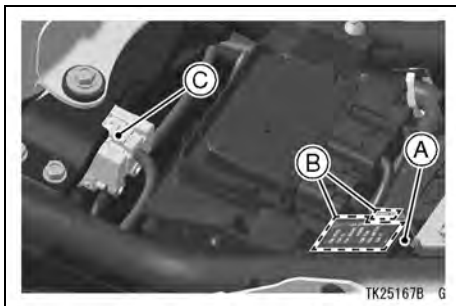

- A. Fuse Box
- B. Fuses
- C. Main Fuse

WARNING

Substituting fuses can cause wiring to overheat, catch fire and/or fail. Do not use any substitute for the standard fuse. Replace the blown fuse with a new one of the correct capacity, as specified on the fuse boxes and main fuse.

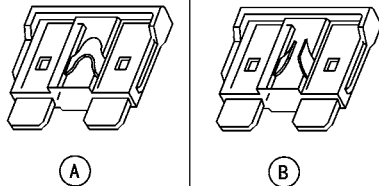

TK25007BZ2 C

- A. Normal
- B. Failed

General Lubrication

Lubricate the points shown below, with either engine oil or regular grease, in accordance with the Periodic Maintenance Chart or whenever the vehicle has been operated under wet or rainy conditions.

Before lubricating each part, clean off any rusty spots with rust remover and wipe off any grease, oil, dirt, or grime.

Apply engine oil to the following pivots

- Side Stand
- Clutch Lever
- Front Brake Lever
- Rear Brake Pedal

Lubricate the following cables with a pressure cable luber

- (K) Clutch Inner Cable
- (K) Throttle Inner Cables

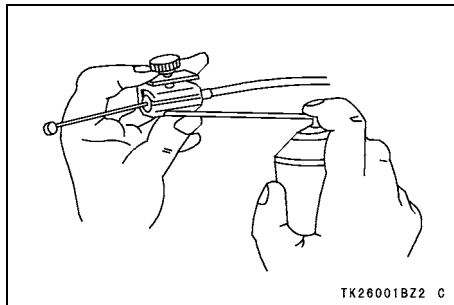

Apply grease to the following points

- (K) Clutch Inner Cable Upper End
- (K) Throttle Inner Cable Upper Ends

(K): Should be serviced by an authorized Kawasaki dealer.

NOTE

- *After connecting the cables, adjust them.*

Cleaning Your Motorcycle

General Precautions

Frequent and proper care of your Kawasaki motorcycle will enhance its appearance, optimize overall performance, and extend its useful life. Covering your motorcycle with a high quality, breathable motorcycle cover will help protect its finish from harmful UV rays, pollutants, and reduce the amount of dust reaching its surfaces.

WARNING

Build-up of debris or flammable material in and around the vehicle chassis, engine, and exhaust can cause mechanical problems and increase the risk of fire.

When operating the vehicle in conditions that allow debris or flammable material to collect in and around the vehicle, inspect the engine, electrical component and exhaust areas frequently. If debris or flammable materials have collected, park the vehicle outside and stop the engine. Allow the engine to cool, then remove any collected debris. Do not park or store the vehicle in an enclosed space prior to inspecting for build-up of debris or flammable materials.

- Be sure the engine and exhaust are cool before washing.
- Avoid applying degreaser to seals, brake pads, and tires.
- Avoid all harsh chemicals, solvents, detergents, and household cleaning products such as ammonia-based window cleaners.
- Gasoline, brake fluid, and coolant will damage the finish of painted and plastic surfaces: wash them off immediately.
- Avoid wire brushes, steel wool, and all other abrasive pads or brushes.
- Use care when washing the headlight lens and other plastic parts as they can easily be scratched.
- Avoid using pressure washers; water can penetrate seals and electrical components and damage your motorcycle.

- Avoid spraying water in delicate areas such as in air intakes, fuel system, brake components, electrical components, muffler outlet, and fuel tank openings.

Washing Your Motorcycle

- Rinse your bike with cold water from a garden hose to remove any loose dirt.
- Mix a mild neutral detergent (designed for motorcycles or automobiles) and water in a bucket. Use a soft cloth or sponge to wash your motorcycle. If needed, use a mild degreaser to remove any oil or grease build up.
- After washing, rinse your motorcycle thoroughly with clean water to remove any residue (residue from the

128 MAINTENANCE AND ADJUSTMENT

detergent can damage parts of your motorcycle).

- Use a soft cloth to dry your motorcycle. As you dry, inspect your motorcycle for chips and scratches. Do not let the water air dry as this can damage the painted surfaces.
- Start the engine and let it idle for several minutes. The heat from the engine will help dry moist areas.
- Carefully ride your motorcycle at a slow speed and apply the brakes several times. This helps dry the brakes and restores them to normal operating performance.
- Lubricate the drive chain to prevent rusting.

NOTE

- *After riding in an area where the roads are salted or near the ocean,*

immediately wash your motorcycle with cold water. Do not use warm water as it accelerates the chemical reaction of the salt. After drying, apply a corrosion protection spray on all metal and chrome surfaces to prevent corrosion.

- *Condensation may form on the inside of the headlight lens after riding in the rain, washing the motorcycle or humid weather. To remove the moisture, start the engine and turn on the headlight. Gradually the condensation on the inside of the lens will clear off.*

Radiator

Clean off any obstructions with a stream of low-pressure water.

NOTICE

Using high-pressure water, as from a car wash facility, could damage the radiator fins and impair the radiator's effectiveness. Do not obstruct or deflect airflow through the radiator by installing unauthorized accessories in front of the radiator or behind the cooling fan. Interference with the radiator airflow can lead to overheating and consequent engine damage.

Semi-gloss Finish

To clean the semi-gloss finish;

- When washing the motorcycle, always use a mild neutral detergent and water.
- The semi-gloss finish effect may be lost when the finish is excessively rubbed.
- If any doubt, consult an authorized Kawasaki dealer.

Other Plastic Parts

After washing use a soft cloth to gently dry plastic parts. When dry, treat the headlight lens and other non-painted plastic parts with an approved plastic cleaner/polisher product.

NOTICE

Plastic parts may deteriorate and break if they come in contact with chemical substances or household cleaning products such as gasoline, brake fluid, window cleaners, thread-locking agents, or other harsh chemicals. If a plastic part comes in contact with any harsh chemical substance, wash it off immediately with water and a mild neutral detergent, and then inspect for damage. Avoid using abrasive pads or brushes to clean plastic parts, as they will damage the part's finish.

Chrome and Aluminum

Chrome and uncoated aluminum parts can be treated with a chrome/aluminum polish. Coated aluminum

should be washed with a mild neutral detergent and finished with a spray polish. Aluminum wheels, both painted and unpainted can be cleaned with special non-acid based wheel spray cleaners.

Leather, Vinyl, and Rubber

If your motorcycle has leather accessories, special care must be taken. Use a leather cleaner/treatment to clean and care for leather accessories. Washing leather parts with detergent and water will damage them, shortening their life.

Vinyl parts should be washed with the rest of the motorcycle, then treated with a vinyl treatment.

The sidewalls of tires and other rubber components should be treated with a rubber protectant to help prolong their useful life.

 **WARNING**

Rubber protectants can be slippery and, if used on the tread area, cause loss of traction resulting in accident causing injury or death. Do not apply rubber protectant to any tread area.

Storage

Preparation for Storage

- Clean the entire vehicle thoroughly.
- Run the engine for about five minutes to warm the oil, shut it off, and drain the engine oil.

WARNING

Engine oil is a toxic substance. Dispose of used oil properly. Contact your local authorities for approved disposal methods or possible recycling.

- Put in fresh engine oil.
- Empty the fuel from the fuel tank by the pump or siphon.

 **WARNING**

Gasoline is extremely flammable and can be explosive under certain conditions, creating the potential for serious burns. Turn the ignition key off. Do not smoke. Make sure the area is well ventilated and free from any source of flame or sparks; this includes any appliance with a pilot light. Gasoline is a toxic substance. Dispose of gasoline properly. Contact your local authorities for approved disposal methods.

- Empty the fuel system by running the engine at idle speed until the engine stalls. (If left in for a long time, the fuel will break down and could clog the fuel system.)

 **WARNING**

An air/oil mist may be forcibly ejected from the spark plug holes and could get into your eyes. Do not lean over the engine when performing this procedure. If you do get oil in your eyes, wash them immediately with liberal amounts of clean, fresh water and consult a physician as soon as possible.

- Reduce tire pressure by about 20%.
- Set the motorcycle on a box or stand so that both wheels are raised off the ground. (If this cannot be done, put boards under the front and rear wheels to keep dampness away from the tire rubber.)

- Spray oil on all unpainted metal surfaces to prevent rusting. Avoid getting oil on rubber parts or in the brakes.
- Lubricate the drive chain and all the cables.
- Remove the battery, and store it where it will not be exposed to direct sunlight, moisture, or freezing temperatures. During storage it should be given a slow charge (one ampere or less) about once a month. Keep the battery well charged especially during cold weather.
- Tie plastic bag over the muffler to prevent moisture from entering.
- Put a cover over the motorcycle to keep dust and dirt from collecting on it.

Preparation after Storage

- Remove the plastic bag from the muffler.
- Install the battery in the motorcycle and charge the battery if necessary.
- Fill the fuel tank with fuel.
- Check all the points listed in the Daily Safety Checks section.
- Lubricate the pivots, bolts, and nuts.

Troubleshooting Guide

Engine Does Not Start

Starter Motor Won't Turn

- Engine stop switch off
- Transmission not in neutral
- Fuse blown
- Battery leads do not make good electrical contact with battery terminals
- Battery discharged

Engine Cranks, But Won't Start

- No fuel in tank
- Fuel line clogged
- Fuel broken down
- Engine flooded
- Spark plugs not in good contact
- Spark plugs fouled or wet
- Incorrect spark plug gap
- Incorrect valve clearance
- No first turning the ignition switch off when the motorcycle falls down

Engine Stalls

Just When Shifting Into 1st Gear

- Side stand has been left down
- Clutch does not properly disengage

While Riding

- No fuel in tank
- Fuel tank air vent is obstructed
- Overheating
- Battery discharged

Environmental Protection

To help preserve the environment, properly discard used batteries, tires, oils and fluids, or other vehicle components that you might dispose of in the future. Consult your authorized Kawasaki dealer or local environmental waste agency for their proper disposal procedure. This also applies to disposal of the entire vehicle at the end of its life.

MAINTENANCE RECORD

Owner Name.....

Address

Phone Number

Engine Number

Vehicle Number.....

Key Code.....

Selling Dealer Name

Phone Number

Warranty Start Date

Note: Keep this information and a spare key in a secure location.

Date	Odometer Reading	Maintenance Performed	Dealer Name	Dealer Address

138 MAINTENANCE RECORD

Date	Odometer Reading	Maintenance Performed	Dealer Name	Dealer Address

MAINTENANCE RECORD 139

Date	Odometer Reading	Maintenance Performed	Dealer Name	Dealer Address

140 MAINTENANCE RECORD

Date	Odometer Reading	Maintenance Performed	Dealer Name	Dealer Address

MAINTENANCE RECORD 141

Date	Odometer Reading	Maintenance Performed	Dealer Name	Dealer Address

142 MAINTENANCE RECORD

Date	Odometer Reading	Maintenance Performed	Dealer Name	Dealer Address