



WARNING

To avoid damage from the scooter's electronic fuel injection system, do not remove or install a battery wire when the ignition switch is at the "ON" position.

Read this manual carefully.

This Owner's Manual contains important information on safety, operation and maintenance of your KYMCO **People GT 125i/200i/300i** scooter. Any one who operates your scooter should carefully read and understand the contents of this manual before riding the scooter. For your safety, understand and follow all of the warnings contained in this Owner's Manual and the labels applied to your scooter. This Owner's Manual should be considered a permanent part of the vehicle, keep it with your scooter at all times. ON-ROAD USE ONLY This scooter has been designed to be used on the road.

Particularly important information is called out in this manual by the following icons and notations:



The SAFETY ALERT symbol with the exclamation point in the triangle means ATTENTION! BE ALERT! YOUR SAFETY CAN BE AFFECTED.

 **WARNING**

Failure to follow instructions associated with a WARNING symbol could result in severe injury or death to the rider, a passenger, a bystander, or a person inspecting or repairing the scooter.

 **CAUTION**

A CAUTION symbol indicates that special precautions must be taken to avoid damaging the scooter.

■ **NOTE**

The NOTE symbol indicates key information about a procedure or to clarify an operation.

Identification Numbers Record

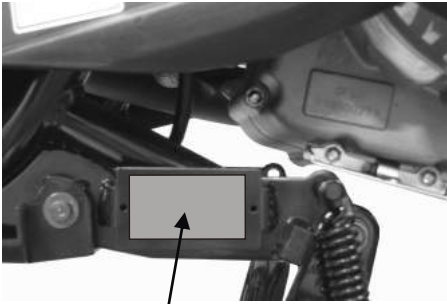

①



②



③

1. VEHICLE IDENTIFICATION NUMBER (VIN)

2. ENGINE SERIAL NUMBER (ESN)

3. FRAME SERIAL NUMBER

Record the Vehicle Identification Number ①, Engine Serial Number ② and Frame Serial Number ③ in the boxes above for future reference (to assist you in ordering parts from your authorized KYMCO dealer or for reference in case the vehicle is stolen).

TABLE OF CONTENTS

❶ SECTION 1 - SAFETY	1 - 8	❷ SECTION 4 - MAINTENANCE	25- 45
Forward	1	Maintenance Schedule.....	26-28
Scooter Safety.....	2 - 3	Engine Oil.....	29
Accessories & Modifications.....	4	Engine Oil Replacement.....	30 - 31
Locations of Parts & Controls.....	5 - 8	Transmission Fluid Change.....	32
❷ SECTION 2 - CONTROLS & FEATURES	9 - 20	Air Filter Element Change.....	33
Ignition Switch	9	Throttle Operation.....	33
Security Shutter	10	Spark Plug.....	34
Instruments	11 - 13	Coolant Level Inspection.....	35
Digital Clock.....	14	Coolant Replacement.....	36
Right-hand Handlebar Switch.....	15	Side Stand.....	37
Left-hand Handlebar Switch.....	16 - 17	Brake Fluid Level Inspection.....	38
Fuel Recommendation.....	18	Brake Pad Inspection.....	39
Seat.....	19	Battery & Fuse.....	40
Helmet Holder.....	19	Tires.....	41
Suspension.....	20	❸ EMISSION CONTROL	43
❸ SECTION 3 - OPERATION	21 - 25	❹ SPECIFICATIONS	45
Pre-ride Inspection.....	21		
Starting the Engine.....	22-23		

SECTION 1 - FORWARD & SAFETY INTRODUCTION

Thank you for purchasing this KYMCO **People GT 125i/200i/300i** scooter, and welcome to the KYMCO riding family.

Please read this owner's manual carefully before riding so that you will be thoroughly familiar with the proper operation of your scooter controls, its features, capabilities, and limitations.

To ensure a long, trouble-free life for your scooter, provide it with the proper care and maintenance as described in this manual.

For replacement parts and accessories, you should always use genuine KYMCO products, as they have been specially designed for your vehicle and manufactured to meet KYMCO's demanding standards.

Keep this owner's manual aboard your scooter at all times so that you can refer to it whenever you need information. This manual should be considered a permanent part of the scooter and should remain with the scooter when it is sold.

All information, illustrations, photographs and specifications contained in this manual are based on the latest product information available at the time of publication. Due to improvements or other changes, there may be information in this manual that differs slightly from your vehicle. KYMCO reserves the right to make product and publication changes at any time without notice and without incurring any obligation.

SCOOTER SAFETY

IMPORTANT SAFETY INFORMATION

Your scooter can provide you many years of service and pleasure if you take responsibility for your own safety and understand the challenges that you can meet on the road. There is much that you can do to protect yourself when you ride. You will find many helpful recommendations throughout this manual. Here are some very important safety tips:

Wear a helmet

Scooter safety equipment starts with a quality helmet. One of the most serious injuries you can suffer in a crash is a head injury. Always wear a properly approved helmet. You should also wear suitable eye protection.

Make yourself easy to see

To make yourself more visible, wear bright reflective clothing, position yourself so other drivers can see you, signal before turning or changing lanes, and use your horn when it will help others notice you.

Know your limits

Ride within the boundaries of your own skill at all times. Knowing these limits and staying within them will help you to avoid accidents.

Keep your scooter in safe condition

For safe riding, it's important to inspect your scooter before every ride and perform all recommended maintenance. Never exceed load limits, and only use accessories that have been approved by KYMCO for this scooter.

Inspect your scooter before riding

Do not forget to perform an entire safety inspection to ensure you, and your passenger's safety, before each ride.

Be extra safety conscious on bad weather days

Riding on bad weather days, especially wet ones, requires extra caution. Braking distance can double on a rainy day. Stay off of the painted surfaces, manhole covers and greasy appearing areas on the pavement, as they can be especially slippery. Use extreme caution at railway crossings and on metal gratings and bridges. Whenever you are in doubt about the road conditions, slow down.

Modification

Modification of your scooter, or removal of original equipment may render the vehicle unsafe or illegal. Obey all applicable equipment regulations in your area.

SCOOTER SAFETY

PROTECTIVE APPAREL

For your safety, always wear an approved motorcycle or scooter helmet, eye protection, boots, gloves, long pants, and a long-sleeved shirt or jacket whenever you ride your scooter.

Helmets and protection

Your helmet is your most important piece of riding gear because it offers the best protection against head injuries. Your helmet should fit your head comfortably and securely. Always wear a face shield or goggles to protect your eyes and to aid your vision.

Additional riding gear

In addition to a helmet and eye protection, you should also use:

- Sturdy boots with nonslip soles to help protect your feet and ankles.
- Leather gloves to keep your hands warm and help prevent blisters, cuts, burns and bruises.
- A motorcycle or scooter riding suit or jacket that has been designed for comfort as well as protection. Bright colored and reflective clothing can help make you more noticeable in traffic. Be sure to avoid loose clothes that could get caught on any part of your scooter.



WARNING

Not wearing a helmet increase your chance of serious injury or death in a crash.

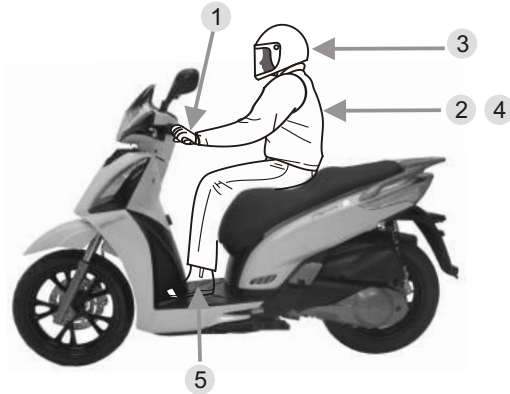

- 1 Wear gloves
- 2 Clothes should be fit properly (not too tight or loose)
- 3 Always wear a helmet. You should also wear eye protection
- 4 Wear bright or reflective clothing
- 5 Footwear should be the proper size, have low heels, and offer ankle protection



WARNING

Be sure you and your passenger always wear an approved motorcycle helmet that fits properly. You should also wear eye protection and other protective apparel when you ride.

ACCESSORIES & MODIFICATION

1 There is a large variety of accessories available to KYMCO scooter owners. KYMCO cannot have direct control over the quality or suitability of accessories you may wish to purchase. The addition of unsuitable accessories to your scooter can lead to unsafe operating conditions. It is not possible for KYMCO to test each accessory on the market or combinations of all the available accessories; however, your KYMCO dealer can assist you in selecting quality accessories and then install them correctly.

Use extreme caution when selecting and installing the accessories for your scooter.

No modifications

KYMCO strongly advises you against removing any original equipment or modifying your scooter in any way that would change its design or operation.



WARNING

Improper accessories or modifications can make your scooter unsafe and can lead to an accident. Never modify your scooter through the improper installation or use of accessories. All parts and accessories added to this vehicle should be genuine KYMCO or equivalent components designed for use on this scooter and should be installed and used according to instruction. If you have any questions, consult an authorized KYMCO dealer.

LOCATION OF PARTS & CONTROLS

- ① Rear Brake Lever
- ② Headlamp
- ③ Left Turn Signal Lamp
- ④ Side Stand
- ⑤ Seat
- ⑥ Air Filter
- ⑦ Taillamp, Stoplamp



■ NOTE: Your scooter may differ slightly in appearance from the images in this manual.

LOCATION OF PARTS & CONTROLS

1

⑧ Coolant Reservoir

⑨ Muffler

⑩ Oil Filler Cap/dipstick

⑪ Fuel Filler Cap

⑫ Rear Passenger Foot Peg

⑬ Right Turn Signal LED

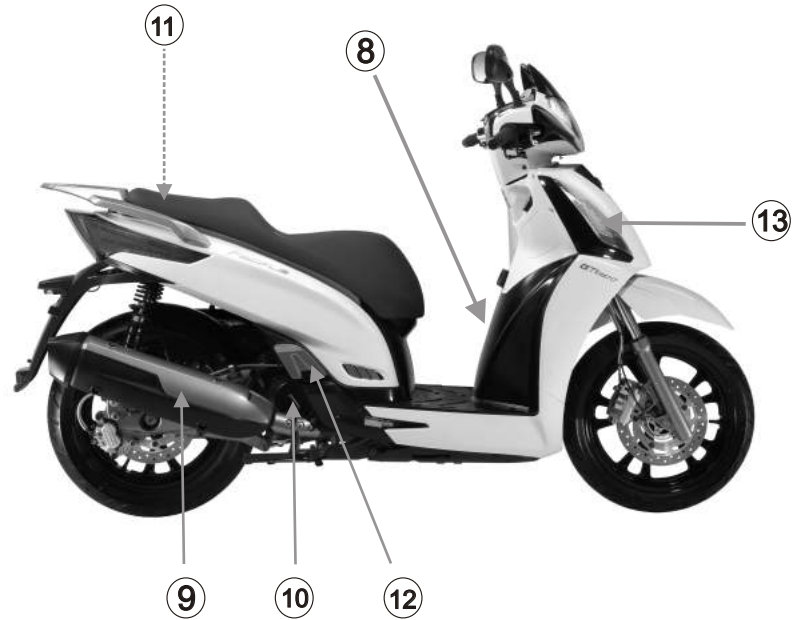

■ NOTE: Your scooter may differ slightly in appearance from the images in this manual.

LOCATION OF PARTS & CONTROLS

- ⑭ Front Turn Signal Lamp
- ⑮ Headlamp(Low Bean Lamp)
- ⑯ Front Brake Lever



■ NOTE: Your scooter may differ slightly in appearance from the images in this manual.

LOCATION OF PARTS & CONTROLS

1

- ①⑦ Rear Turn Signal LED
- ①⑧ Engine Stop Switch
- ①⑨ Ignition Switch
- ①⑩ Battery and fuses
- ①⑪ Taillamp, Stoplamp
- ①⑫ Cell Phone Socket

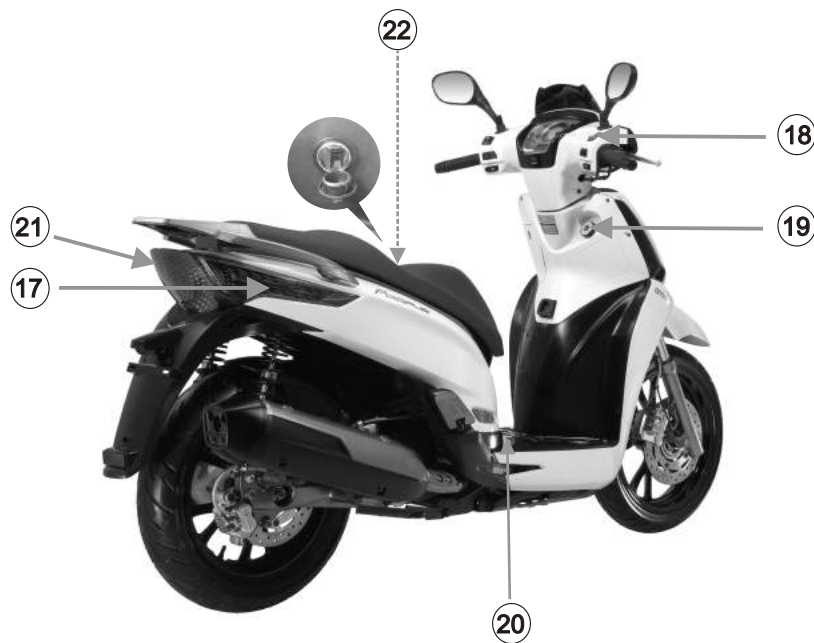

SECTION 2 - CONTROLS&FEATURES

IGNITION SWITCH

To operate the ignition switch and it's functions:

“ ” **Position:**

All electrical circuits are off. The engine will not start or run.

“ ” **Position:**

The ignition circuit is "ON" and engine can now be started. The key can not be removed from the ignition switch in this position.

“ ” **Position:**

To lock the steering, turn the handlebar all the way to the left, push down and turn the key to the "  " position and remove the key. All electrical circuits are off.



CONTROLS & FEATURES

SECURITY SHUTTER

To open the ignition switch security shutter:

Push the shut-button on the ignition switch cover and then the shutter ① should be closed.

To shut the ignition switch security shutter:

Insert the specific key ② until the fillister ③ is facing the pin.

Turn clockwise and then the security shutter should be opened.

The keys have a unique code that is stamped on the tab supplied with the keys. This code is not stamped on the scooter and is not recorded in the vehicle's basic documentation for security reasons. Since this code is required if you need replacement keys, record this important code in the box provided on the inside of this Owner's Manual.

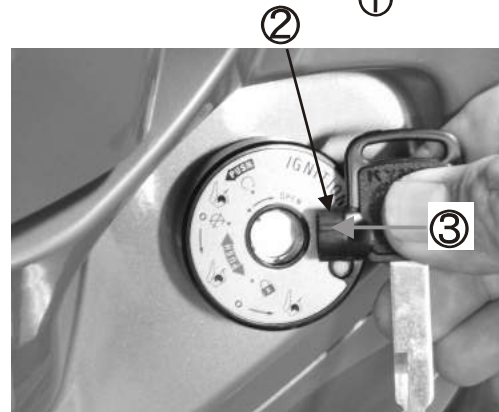

CONTROLS & FEATURES

Instruments

- ① Odometer/Tripmeter: Press the "MODE" button to toggle between the overall and trip mileage.
 - Press the "ADJ" button for two seconds, then displays the ODO, TRIP(A,B) or SERVICE mode.
 - Press the "ADJ" and "MODE" button simultaneously at the TRIP mode, then the figure reset automatically.
- ② Speedometer: Indicates the road speed in K/PH (kilometers per hour).
- ③ Turn Signal Indicator Light: Flashes when either turn signal is being used.
- ④ High Beam Indicator Light: This light is illuminated when the headlight high beam is on.
- ⑤ Fuel refill indicator "  ": This indicator lights when the fuel tank is near empty to alert the rider to refill the fuel tank as soon as possible.
- ⑥ Clock
- ⑦ Coolant temperature gauge

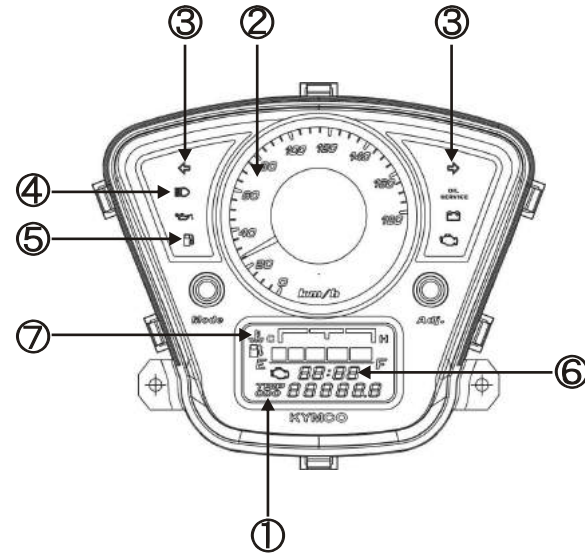

CONTROLS & FEATURES

- ⑧ CELP indicator: If flashing, it indicates that a fault has been detected in the scooter's EFI or electrical system. Requires immediate inspection by a KYMCO dealer.

■ **NOTE:** The CELP indicator lights momentarily when the scooter is turned ON before the engine is running.

- ⑨ Oil service indicator: Lights when the scooter has reached the oil service interval mileage. The indicator also lights when the ignition is turned ON but should go out once the engine is running.

- Press the ADJ. button for two second, then displays the ODO, TRIP or SERVICE mode.
- Press the ADJ. and MODE button simultaneously at the SERVICE mode, then the indicator go out automatically.

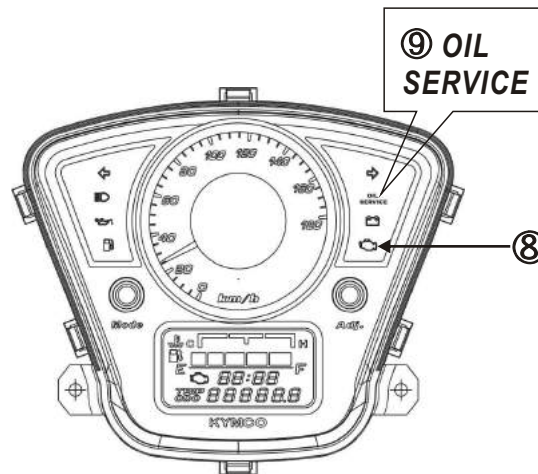

- ⑩ Battery voltage indicator:
If the battery voltage is too low while starting the engine. The indicator can be lighting. The engine fails to be restarted unless the battery should be recharged completely.
- ⑪ Oil pressure indicator: <People GT 300i>
This indicator lights when the oil pressure is below the normal operating pressure. The indicator will light when the ignition switch is “ON” and the engine is not running. The indicator should go out when the engine starts (except for some occasional flickering at or near idle when the engine is warm). If the indicator fails to go out completely once the engine is started, consult your KYMCO dealer immediately.

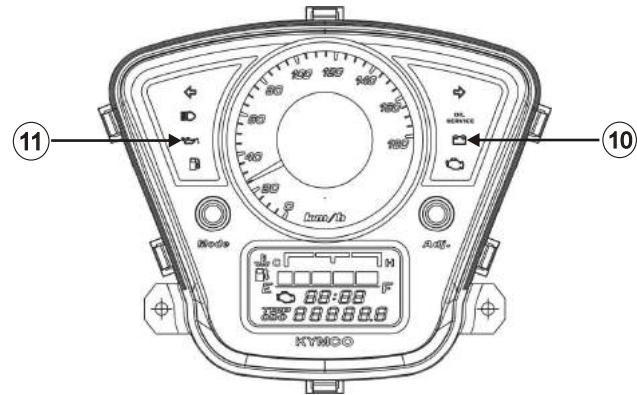

CAUTION

Running the engine on your scooter with insufficient oil pressure will cause serious engine damage.

CONTROLS & FEATURES

Multifunction display - Digital clock

The clock indicates the time in hours and minutes when the ignition is "ON".

To adjust the clock's time manually, follow this procedure:

1. Turn the ignition switch "ON"
2. Press and hold the ADJUST button for more than two seconds to select the ODO mode.

NOTE: The digital clock can be only adjusted in ODO mode, don't select the tripmeter or oil service meter mode if you want to adjust the time on the clock.

3. Press and hold both the Mode button and Adjust button at the same time for more than two seconds. The "hour" digits will begin flashing, indicating the clock time can be adjusted.

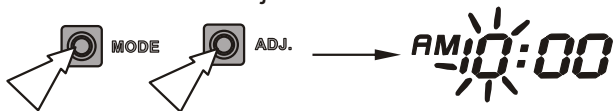

4. To set the hour display, press the ADJUST button until it displays the correct "hour" time

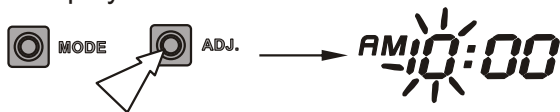

5. To change the minute display, press the MODE button until the "minute" digits begin flashing



6. To set the minute display, press the ADJUST button until it displays the correct "minute" time

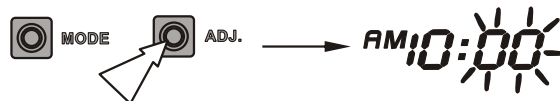

7. To end the clock adjustment, press both the MODE and ADJUST buttons at the same time. The display will stop flashing automatically. The adjustment will be saved the last setting figure and back to the general display if any button is not pressed within approximately ten seconds.



CONTROLS & FEATURES

Headlight switch ① " ☀ " position:

The headlight and taillight will be lit.

" 🚦 " position:

The position light and taillight (running lamps) will be lit.

" ● " position:

The headlight and taillight will be off.

Electric starter button ② " ⚡ " position:

Press the electric starter button to activate the starter motor.

Engine stop switch ③ " ✖ " position:

The ignition circuit is off. The engine will not start or run.

" ↻ " position:

The ignition circuit is on, and the engine can start and run.



■ **NOTE:** The starter motor will not engage unless a brake lever is squeezed at the same time the starter button is pressed.

People GT 300i is also equipped with a safety interlock that prevents the starter motor from being engaged unless the side-stand is fully up.

CONTROLS & FEATURES

Turn signal switch ④ :

Use the turn signal indicator to signal to other traffic your intention to turn or change lanes. The turn signal light on the dash will flash to alert the rider that the switch is engaged.

"←" for turning to the "left".

"→" for turning to the "right".

To cancel the turn signal, press the switch in when it is in the center position.

Horn button ⑤ :

Press the horn button to sound the horn.



CONTROLS & FEATURES

Dimmer switch ⑥ :

"☰☞" switch position turns the headlight low beam on.

"☷☞" switch position turns the headlight high beam on and the high beam indicator light on the dash is activated as well.

Passing light button ⑦ :

Use this button to rapidly flick the headlamp high beam on and off to signal other vehicles that you wish to pass.

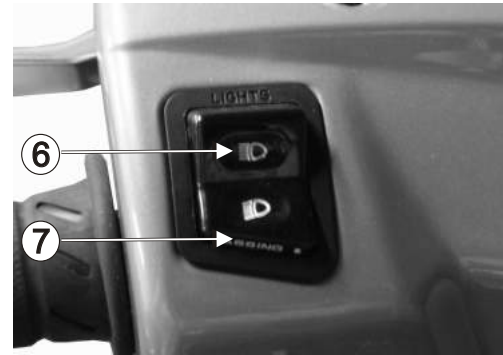

CONTROLS & FEATURES

Fuel level inspection / Refilling

If the low fuel indicator on the dash begins to flash, refill the fuel tank with nonleaded gasoline as soon possible.

Fuel tank filler :

To add fuel to your scooter, follow this procedure:

- ❶ Use the ignition key to unlock the seat.
- ❷ Unlock the fuel filler cap counterclockwise.
- ❸ Once unlocked , lift the cap from the fuel filler neck.
- ❹ To install the fuel filler cap, clockwise to lock the cap.

Fuel recommendation

Use nonleaded gasoline with a research octane number of 91 or higher to prevent from spark plug and exhaust component damaged.

After refueling, be sure to close the filler cap securely.

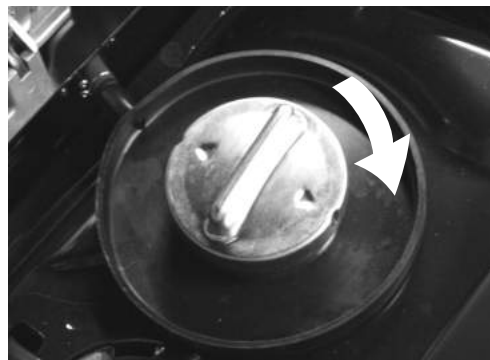

CONTROLS & FEATURES

Seat

To unlock the seat

With the ignition key at the "🔑" position (the engine is running), push the key in and turn it counterclockwise from "🔑" to the "👉" position.

With the ignition key in the "🚫" position (the engine is not running), turn the counterclockwise from the "🚫" to the "👉" position.

Pull up on the back portion of the seat to lift it up.

Helmet holder

To use the helmet holder, open the seat and hook your helmet's fastener ring to the holder (8) and close the seat securely.

WARNING

Use the helmet holder only when your scooter is parked. Do not ride with a helmet hanging from the holder.

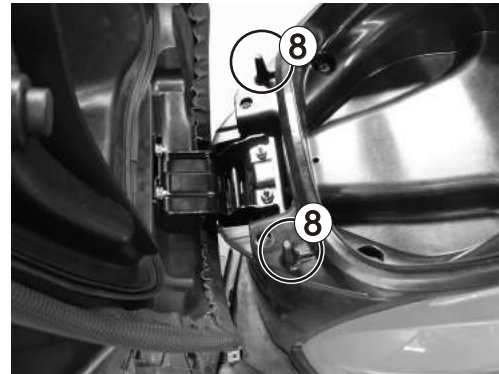

CONTROLS & FEATURES

Suspension

Each shock absorber on your scooter has five spring preload adjustment positions for different load or riding conditions.

Use a pin spanner to adjust the rear shock spring preload. Position 1 is for light loads and smooth road conditions. Position 3 to 5 increase spring preload for a stiffer rear suspension and can be used when the scooter is heavily loaded.

Be certain to adjust both shock absorbers to the same spring preload positions.

Standard spring preload position:

People GT 125i: 1st

People GT 300i: 2nd

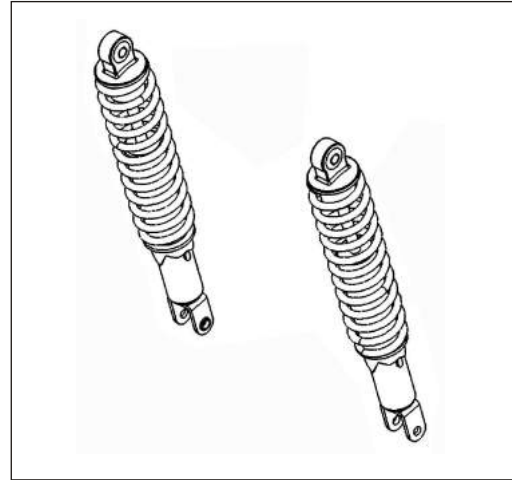

CAUTION

Always adjust the shock absorber pre-load position in sequence (1-2-3-4-5 or 5-4-3-2-1). Attempting to adjust directly from 1 to 5 or 5 to 1 may damage the shock absorber.

SECTION 3 - OPERATION

Pre-ride inspection

For your safety, it is very important to take a few moments before each ride to walk around your scooter and check its condition. If you detect any problem, be sure to address it immediately, or have it corrected by your KYMCO dealer.



WARNING

Improperly maintaining your scooter or failing to correct a problem before riding can cause a crash in which you can be seriously hurt or killed.

Always perform a pre-ride inspection before every ride and correct any problems.

1. Engine oil level: Add engine oil if required (page 29). Check for leaks.
2. Fuel level: Fill fuel tank when necessary (page 18). Check for leaks.
3. Front and rear brakes: Check operation, make sure there is no brake fluid leakage (page 40).
4. Tires: Check condition and inflation pressure (page 41).
5. Throttle: Check for smooth operation and that it closes completely in all steering positions (page 33).
6. Lights and horn: Check that headlight, tail/brake light, turn signals, indicators and horn function properly.
7. Steering: Check for condition and smoothness.

OPERATION

Starting the engine

Always follow the proper starting procedure described here and on the following pages.

CAUTION

To protect the catalytic converter in your scooter's exhaust system, avoid idling for extending periods of time and do not use leaded gasoline.

CAUTION

To prevent damage to the starter motor, do not operate the starter motor for more than five seconds at a time. If the scooter fails to start immediately, check the fuel level and the battery condition, and allow the starter motor to cool before attempting to start the engine again.

1. Place your scooter on its center stand and put the side stand up.
2. Insert the ignition key and rotate the ignition switch to "  " ON.



OPERATION

3. Squeeze the left (rear) brake lever.

■ **NOTE:** The electric starter will only work when the left(rear) or right(front) brake lever is squeezed.

4. With the throttle closed, press the starter button ①.

Release the starter button as soon as the engine starts.



CAUTION

Operating your scooter's engine with insufficient oil pressure can cause serious engine damage.

5. Keep the throttle closed while warming up the engine

6. Keep the engine to warm up fully before riding.

MEMO

SECTION 4 - MAINTENANCE

The importance of maintenance

Maintaining your scooter properly is essential for safe, economical and trouble-free riding. It will also help reduce air pollution and maximize fuel economy.

To help you properly care for your scooter, the following pages in this Owner's Manual include a maintenance schedule to help you make sure your scooter is serviced at the appropriate intervals.

These instructions are based on the assumption that your scooter will be used exclusively for its designed purpose. Sustained high speed operation or operation in unusually wet or dusty conditions will require more frequent service than specified in the maintenance schedule. Consult your KYMCO dealer for recommendations applicable to your individual needs and use.

■ **NOTE:** Always follow the inspection and maintenance recommendations and schedules in this Owner's Manual.

WARNING

If your scooter tips over or becomes involved in a crash, be sure your KYMCO dealer inspects all major parts, even if you are able to make some repairs.

Improperly maintaining this scooter or failing to correct a problem before you ride could result in a crash in which you could be seriously hurt or killed.

WARNING

When performing maintenance on your scooter you may need to start the engine. Running your scooter's engine indoors or in a garage can be hazardous. Exhaust gas contains carbon monoxide, a gas that is colorless and odorless, and can cause death or severe injury. Operate the engine only where there is adequate ventilation, preferably outdoors.

MAINTENANCE

Maintenance schedule

Perform the pre-ride inspection (see page 21) at each scheduled maintenance period. This interval should be judged by odometer reading or months, whichever comes first.

Maintenance schedule legend (see page 27 and 28):



I: INSPECT AND CLEAN, ADJUST, LUBRICATE OR REPLACE IF NECESSARY

C: CLEAN R: REPLACE A: ADJUST L: LUBRICATE

The maintenance schedule on the following two pages specifies the maintenance required to keep your **People GT 125i/200i/300i** scooter in peak operating condition. Maintenance work should be performed in accordance with KYMCO standards and specifications by properly trained and equipped technicians. Your KYMCO dealer meets all of these requirements.

- * Should be serviced by your KYMCO dealer, unless you have the proper tools, service data and are technically qualified.
- ** In the interest of safety, we recommend these items be serviced only by your KYMCO dealer. KYMCO recommends that your KYMCO dealer road test your scooter after each periodic maintenance service is completed.

MAINTENANCE

ITEM	FREQUENCY	WHICHEVER COMES FIRST		ODOMETER READING							REFER TO PAGE	
				X 1000 km	1	5	10	15	20	25		30
				X 1000 mi	0.6	3	6	9	12	15		18
MONTH	1	6	12	18	24	30	36					
*	AIR CLEANER				R	R	R	R	R	R	R	33
	SPARK PLUGS				I	R	I	R	I	R		34
*	THROTTLE OPERATION				I	I	I	I	I	I		33
*	VALVE CLEARANCE				I	A	I	A	I	A		-
*	FUEL LINE					I		I		I		-
	CRANKCASE BREATHER				C	C	C	C	C	C	C	-
*	ENGINE OIL				R	R	R	R	R	R	R	29
*	ENGINE OIL SCREEN					C	R	C	R	C	R	-
*	ENGINE OIL FILTER				R	R	R	R	R	R	R	-
*	ENGINE IDLE SPEED						I		I		I	-
*	TRANSMISSION FLUID				R	R	R	R	R	R	R	32
*	DRIVE BELT					I	I	I	R	I	I	-

MAINTENANCE

ITEM		FREQUENCY	WHICHEVER COMES FIRST	ODOMETER READING						REFER TO PAGE
				X 1000 km	1	5	10	15	20	
		X 1000 mi	0.6	3	6	9	12	15	18	
		MONTH	1	6	12	18	24	30	36	
**	CLUTCH SHOE WEAR									-
	BRAKE FLUID				R		R		R	38
	BRAKE PAD WEAR									39
	BRAKE SYSTEM									-
*	BRAKE LIGHT SWITCH									-
**	STEERING BEARINGS									-
*	HEADLIGHT AIM									-
*	NUTS, BOLTS, FASTENERS									-
**	WHEELS/TIRES									41
**	COOLANT				R		R		R	36

MAINTENANCE

Engine oil

Engine oil recommendation

Use a premium quality 4-stroke engine oil to ensure longer service life of your scooter. Only use oils that have a SJ rating above per the API service classification.

Engine oil viscosity :

SAE15W-40 (for People GT 125i)

SAE 5W-50 (for People GT 200i/300i)

If these viscosities are not available, select an alternative engine oil according to the chart shown below.

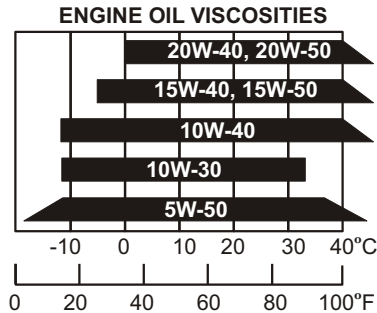

Engine oil capacity:

1.2 L (for People GT 125i)

1.5 L (for People GT 200i/300i)

Engine oil level inspection

Check the engine oil level each day before riding your scooter. The level must be maintained between the upper ① and lower level ② marks on the oil filler cap/dipstick ③ .



<People GT 200i/300i>

1. Start the engine and let it idle for a few minutes.

CAUTION

Running the engine with insufficient oil pressure can cause serious engine damage.

2. Stop the engine and put the scooter on its center stand on level ground.

MAINTENANCE

3. After a few minutes, remove the oil filler cap/dipstick, wipe it clean, and reinsert the oil filler cap/dipstick without screwing it in. Remove the oil filler cap/dipstick. The oil level should be between the upper and lower marks on the oil filler cap/dipstick.
4. If required, add the specified oil so the oil level touches the upper level mark on the dipstick. Do not overfill.
5. Reinstall the oil filler cap/dipstick ③ . Check for oil leaks.

WARNING

The engine and related components can become very hot. Use care when inspecting the oil level so you do not burn yourself. If needed, let the engine and exhaust system cool before working in those areas.

Engine oil replacement

Engine oil quality is the primary factor that affects engine longevity. Change your scooter's engine oil as specified in the maintenance schedule .

■ NOTE: Change the engine oil with the engine at normal operating temperature and the scooter on its center stand to assure complete and rapid draining.



<People GT 200i/300i>

1. Remove the oil filler/dipstick ③ from the right crankcase cover.
2. Place a suitable container (drain pan) under the left crankcase.

MAINTENANCE

3. Remove the oil drain plug ④ from the crankcase to drain the oil.
4. Reinstall the drain plug and tighten it to the specified torque.
5. Add oil to the engine per the amounts listed below, and reinstall the oil filler/dipstick.

	125i	200i/300i
Capacity	1.2L	1.5L
At change	1.0L	1.3L

6. Start the engine and let it idle for 2 - 3 minutes.
7. Stop the engine and check the oil level on the dipstick when the scooter is parked on the center stand, on level ground.
8. Adjust the oil level as required (so the level reaches the upper mark on the dipstick). Replace the dipstick and inspect for any leaks.



CAUTION

Running the engine with insufficient oil pressure can cause serious engine damage.

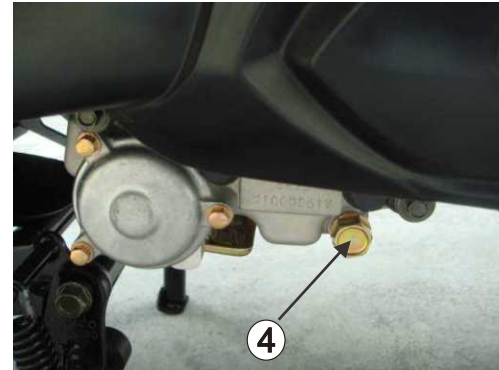

<People GT 125i>

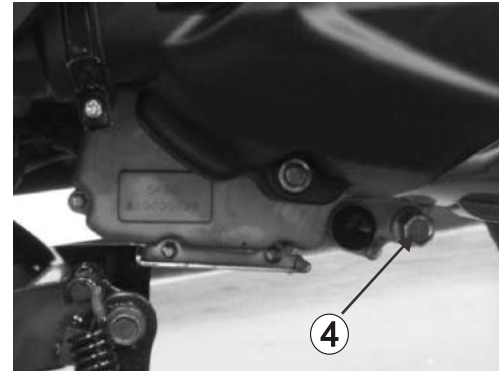

<People GT 200i/300i>

MAINTENANCE

Transmission fluid change

1. Place the scooter on its center stand.
2. Remove the transmission fluid drain bolt ⑦.
3. Remove the transmission fluid filler bolt ⑧, then slowly rotate the rear wheel to drain the fluid.
4. Fill the transmission with the recommend fluid to the capacity listed below.

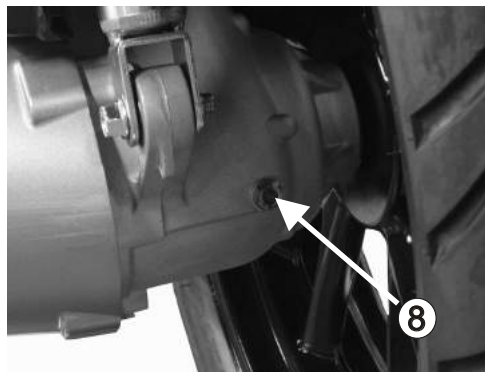
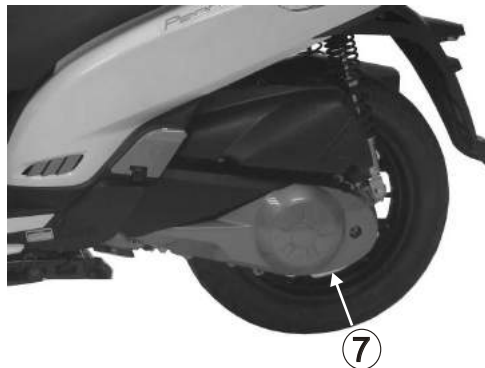

<People GT 300i>

4

Transmission fluid type: SAE 90

	125i	200i/300i
Capacity	0.13L	0.23L
At change	0.12L	0.21L

5. Install the transmission filler bolt and tighten it to the specified torque.

MAINTENANCE

Air cleaner filter element

The air cleaner filter element ⑨ should be serviced at regular intervals by a KYMCO dealer, unless you have the proper tools, service data and are technically qualified to do so.

Have the element serviced more often when riding in unusually wet or dusty areas.

CAUTION

Using the wrong KYMCO air cleaner element or a non-KYMCO air cleaner element which is not of equivalent quality may cause premature engine wear or performance problems.

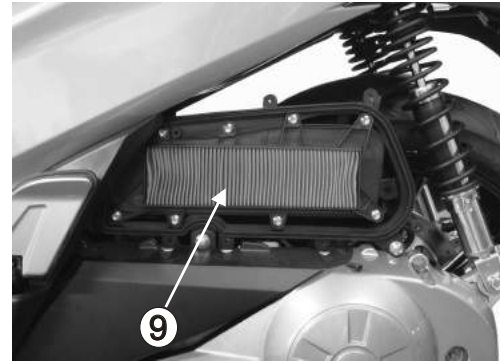

Throttle operation

1. Before each ride, check for smooth throttle grip rotation from the fully open to the fully closed position at both full steering positions.
2. Measure the throttle grip free play at the throttle grip flange (per the illustration right).

Throttle free play:

0.08-0.24 in (2.0 - 6.0 mm)

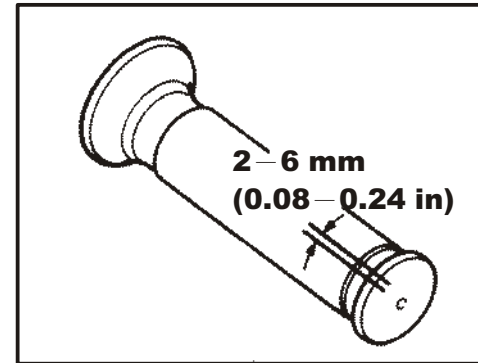

MAINTENANCE

Spark plug

Remove the carbon deposits from the spark plug with a small wire brush or a spark plug cleaning machine. After cleaning (or when installing a new spark plug) readjust the spark plug gap to specified limit by using a spark plug gap thickness gauge. The spark plug should be replaced periodically.

Whenever removing the carbon deposits, be sure to observe the color of the removed spark plug's porcelain tip. This color tells you whether or not the standard spark plug is suitable for your type of riding. Under normal usage, a spark plug's porcelain tip should be light brown or tan color.

If the spark plug porcelain tip is very white or glazed appearing, then the spark plug has been operating too hot. In such a situation, you should replace the standard spark plug with a spark plug that has a colder heat range (usually a higher number; consult with your KYMCO dealer when selecting an alternate spark plug).

Recommended spark plug: CR7E (NGK)

CAUTION

An improper spark plug may have an incorrect fit or heat range for your engine. This may cause severe engine damage which will not be covered under warranty. Never use a spark plug with an improper heat range, as severe engine damage could result.

**Spark plug gap: 0.024 - 0.028 in
(0.6 - 0.7 mm)**

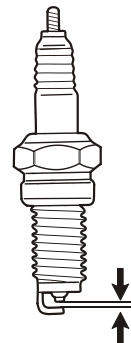
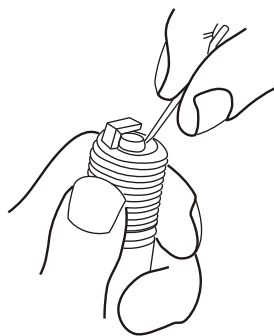

MAINTENANCE

Coolant level inspection

The reserve tank is under right floorboard. Check the coolant level through the inspection window ① at the right side skirt white the engine is at the normal operating temperature , with the scooter in an upright position.

If the coolant level is below the LOWER level mark ② , remove the floor mat , remove the reserve tank lid and then the reserve tank cap to add coolant mixture until it reaches the upper level mark ③ .

WARNING

Add coolant to the reserve tank only. Do not attempt to add coolant by removing the radiator cap. Coolant in the radiator is under pressure and is very hot and can cause serious burns.

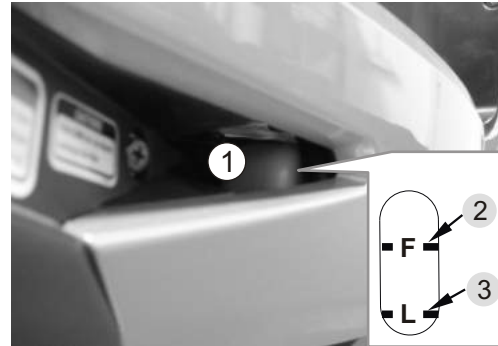

MAINTENANCE

Coolant replacement

The coolant in your scooter should be replaced by a KYMCO dealer, unless you have the proper tools, access to service data, and are technically qualified.

NOTE: Always add coolant to the reserve tank. Do not attempt to add coolant by removing the radiator cap.

WARNING

Removing the radiator cap while the engine is hot can cause the coolant to spray out, seriously scalding you. Always let the engine and radiator cool down before removing the radiator cap.

Coolant recommendation

It is your responsibility to have your scooter serviced so it has the proper type and amount of coolant in the cooling system and engine. The coolant must be in good condition and have the proper ratio of antifreeze and distilled water to prevent freezing, overheating, and corrosion. When servicing the coolant, you should arrange to use only high quality ethylene glycol antifreeze that contains corrosion protection inhibitors specifically formulated for use in aluminum engines (see the antifreeze container label).

A 40:60 solution of antifreeze and distilled water is required for the cooling system of your scooter. This coolant solution is recommended for most operating temperatures and provides good corrosion protection.

CAUTION

Use only low-mineral drinking water or distilled water as a part of the antifreeze solution. Water that is high in mineral content or salt may be harmful to the aluminum engine. Using coolant with silicate inhibitors may cause premature wear of water pump seals or blockage of radiator passages. Using tap water can cause engine damage.

If you are using your scooter in an environment where it will encounter freezing temperatures, you should have a higher concentration of antifreeze installed by your KYMCO dealer to provide additional protection against freezing the engine. This higher concentration should not exceed 60% antifreeze -to -distilled water.

During warmer times, bring the antifreeze ratio back to the standard ratio. A concentration of less than 40:60 (40% antifreeze) will not provide proper corrosion protection.

MAINTENANCE

Side stand

Your scooter's side stand is not only necessary when you park, but it contains an important safety feature. This feature cuts-off the ignition if you try to ride the scooter when the side stand is down. Perform the following side stand inspection.

Interlock function check:

Check the side stand ignition cut-off system:

1. Place the scooter on its center stand.
2. Put the side stand up and start the engine.
3. Lower the side stand. The engine should stop as you put the side stand down.

■ **NOTE:** If the side stand system does not operate as described, see your KYMCO dealer for service.



MAINTENANCE

Brake fluid

Brake fluid level inspection

With the scooter in an upright position, check the front and rear fluid level.

The level should be above the lower level mark. If the level is at or below the lower level mark "L", check the brake pads for wear.

■ **NOTE:** Other checks - make sure there are no fluid leaks. Check for deterioration or cracks in the hoses and fittings.

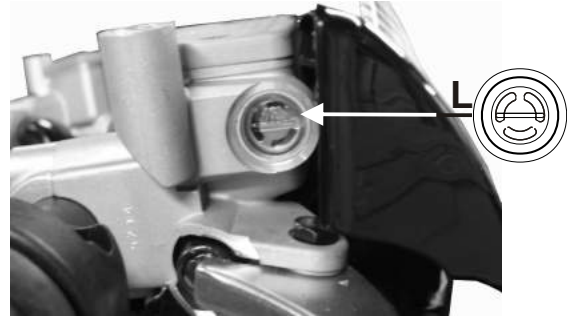

4

WARNING

Worn brake pads should be replaced immediately. If the pads are not worn, have your brake system inspected for leaks. Do not ride your scooter unless the brakes are in perfect working order.

Brake fluid type: DOT 4

MAINTENANCE

WARNING

For appropriate brake action, make sure the groove of the adjusting nut is aligned with the pin in the brake arm.

Inspect the brake pad and shoe thickness to verify there is enough material for the brakes to function properly.

1. If the wear indicator grooves in the front brake pads are no longer visible ③, it is an indication that the brake pads are worn and require replacement.
2. If the wear indicator grooves in the rear brake pads are no longer visible ④, it is an indication that the brake pads are worn and require replacement.

WARNING

The brakes will wear quickly if the lever is continually applied during riding (dragging the brake). Consult your KYMCO dealer for braking system service.

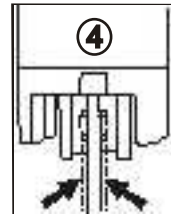
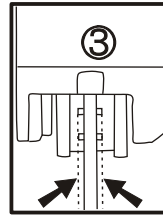

MAINTENANCE

Battery

Your KYMCO scooter is equipped with a maintenance-free (sealed) type battery so it is not necessary to check the battery's electrolyte level or add distilled water.

■ **NOTE:** If your battery seems weak and/or is leaking electrolyte (causing hard starting or other electrical troubles), contact your KYMCO dealer immediately.

CAUTION

Your battery is a maintenance-free type and can be permanently damaged if the cap strip is removed.



Fuse

When frequent fuse failures occur, it usually indicates a short circuit or an overload in the electrical system.

■ **NOTE:** See your KYMCO dealer for electrical system diagnosis and repair.

WARNING

Never use a fuse with a different rating from that specified. Serious damage to the electrical system or a fire may result, causing a dangerous loss of lights or engine power.

Fuses list

30A ... CHARGE fuse protects battery charging system.

15A ... MAIN fuse protects all electrical circuits.

15A ... HEAD-HI/LO fuse protects the headlight high/low beam and clock.

10A ... IGNITION fuse protects the ignition system.

10A ... FAN fuse protects the cooling fan motor.

MAINTENANCE

Tires



WARNING

Failure to follow these warnings may result in an accident due to tire failure. The tires on your scooter are a crucial link between your scooter and the road. You and your passenger's personal safety are dependant upon the condition of your scooter's tires.

Follow these instructions:

- Check tire condition and pressure, and adjust the inflation pressure before each ride.
- Avoid overloading your scooter.
- Replace a tire when worn to the specified limit, or if you find any damage such as cuts or cracks.
- Always use the proper size and type of tires as specified in this Owner's Manual.
- Balance the wheel after tire installation.
- Read this section of Owner's Manual carefully.

Failure to perform a reasonable break-in of the tires could cause tire slip and loss of control.

Use extra care when riding on new tires as the grip will be limited. Perform proper break-in of the tires, as stated in the break-in recommendation section of this manual. Avoid hard acceleration, hard cornering, and hard braking for the first 100 miles (160 km).

■ **NOTE:** Check the tire inflation pressure and tire tread condition at the periods listed in the periodic maintenance schedule. For maximum safety and good tire life, the tire pressures should be inspected more often.

Tire pressure

Insufficient air pressure in the tires not only accelerates tire wear but it also affects the stability of your scooter. Under-inflated tires make smooth cornering difficult and overinflated tires decrease the amount of tire in contact with the ground, which can lead to skids and loss of control. Make sure that the tire pressures on your scooter are within the specified limits at all times.

■ **NOTE:** Tire pressure should only be adjusted when the tires are cold.

Front tire (rider only): 24.85 PSI (1.75 kgf/cm²)

Rear tire (rider only): 28.40 PSI (2.00 kgf/cm²)

Front tire (rider & passenger): 24.85 PSI (1.75 kgf/cm²)

Rear tire (rider & passenger): 32.0 PSI (2.25 kgf/cm²)

MEMO

EMISSION CONTROL

Crankcase Emission Control System

Your **People GT 125i/200i/300i** engine is equipped with a closed crankcase system. Blow-by gases are routed back in to the combustion chamber via the intake system. This system does not allow the blow-by gases to enter the atmosphere.

Exhaust Emission Control System

The exhaust emissions from your **People GT 125i/200i/300i** scooter are controlled by engine design, factory-set fuel delivery, ignition settings, and exhaust system design. This system also includes a catalyzer in the exhaust system.

Noise Exhaust Emission Control System

The engine, intake and exhaust systems of your **People GT 125i/200i/300i** scooter were designed to comply with federal, state and local noise level requirements. Do not modify the engine ,intake or exhaust components, as doing so will affect compliance these noise level requirements.

Please do not modify or change any KYMCO-designed components that may alter the sound or emission level from your **People GT 125i/200i/300i** scooter.

MEMO

SPECIFICATIONS - People GT 125i

Dimensions

Overall length.....	85 in (2130 mm)
Overall width.....	30 in (750 mm)
Overall height.....	51 in (1280 mm)
Wheel base.....	58 in (1450 mm)

Capacities

Engine oil.....	1.2L
Transmission oil.....	0.13L
Fuel tank.....	9L
Net weight.....	334lbs(152kg)

Engine

Type.....	Four-stroke,liquid -cooled SOHC
Displacement.....	124.8 cc (7.49 cu. in)
Bore and stroke.....	2.16in X 2.18in (54 X 54.5 mm)
Compression ratio.....	11.7:1
Max. Horsepower Engine.....	14.3ps/9000rpm
Spark plug.....	CR7E
Idle speed.....	1800 RPM
Cooling system.....	liquid-Cooled
Starting system.....	Electric starter
Transmission.....	Automatic CVT

Chassis

Tire size, front	110/70-16
Tire size, rear.....	140/70-16
Brake(front).....	DISK
Brake(rear).....	DISK

Electrical

Ignition type	Digital Inductive Ignition
Ignition timing.....	ECU control
Battery.....	12V12AH
Headlight.....	12V60W/55W
Tail/brake light.....	12V5W/21W
Turn signal light(Front/Rear).....	12V10W/2W(LED)
Fuse.....	30A/15A/10A

SPECIFICATIONS - People GT 200i

Dimensions

Overall length.....85 in (2130 mm)
 Overall width.....30 in (750 mm)
 Overall height.....51 in (1280 mm)
 Wheel base.....58 in (1450 mm)

Capacities

Engine oil.....1.5L
 Transmission oil.....0.23L
 Fuel tank.....9L
 Net weight.....344lbs(156.2kg)

Electrical

Ignition typeDigital Inductive Ignition
 Ignition timing.....ECU control
 Battery.....12V12AH
 Headlight.....12V60W/55W
 Tail/brake light.....12V5W/21W
 Turn signal light(Front/Rear)....12V10W/2W(LED)
 Fuse.....30A/15A/10A

Engine

Type.....Four-stroke OHC
 Valve train.....OHC & CENTER PIVOT
 Displacement.....205cc
 Bore and stroke.....2.64in X 2.40in (66 X 60 mm)
 Compression ratio.....10.3:1
 Max. Horsepower Engine.....20.6ps/8000rpm
 Max. Torque Engine.....2.03kg.m/6500rpm
 Spark plug.....CR7E
 Idle speed.....1600 RPM
 Cooling system.....liquid-Cooled
 Starting system.....Electric starter
 Transmission.....Automatic CVT

Chassis

Tire size,front110/70-16
 Tire size,rear.....140/70-16
 Brake(front).....DISK
 Brake(rear).....DISK

SPECIFICATIONS - People GT 300i

Dimensions

Overall length.....	85 in (2130 mm)
Overall width.....	30 in (750 mm)
Overall height.....	51 in (1280 mm)
Wheel base.....	58 in (1450 mm)

Capacities

Engine oil.....	1.5L
Transmission oil.....	0.23L
Fuel tank.....	9L
Net weight.....	363lbs(165kg)

Electrical

Ignition type	Digital Inductive Ignition
Ignition timing.....	ECU control
Battery.....	12V12AH
Headlight.....	12V60W/55W
Tail/brake light.....	12V5W/21W
Turn signal light(Front/Rear)....	12V10W/2W(LED)
Fuse.....	30A/15A/10A

Engine

Type.....	Four-stroke OHC
Valve train.....	OHC & CENTER PIVOT
Displacement.....	298.9 cc
Bore and stroke.....	2.91in X 2.88in (72.7 X 72 mm)
Compression ratio.....	10.8:1
Max. Horsepower Engine.....	28ps/7750rpm
Max. Torque Engine.....	2.7kg.m/6500rpm
Spark plug.....	CR7E
Idle speed.....	1600 RPM
Cooling system.....	liquid-Cooled
Starting system.....	Electric starter
Transmission.....	Automatic CVT

Chassis

Tire size,front	110/70-16
Tire size,rear.....	140/70-16
Brake(front).....	DISK
Brake(rear).....	DISK