

## FOREWORD

This handbook contains information on the Triumph Bonneville, Bonneville SE, Bonneville T100, Thruxton and Scrambler motorcycles. Always store this owner's handbook with the motorcycle.

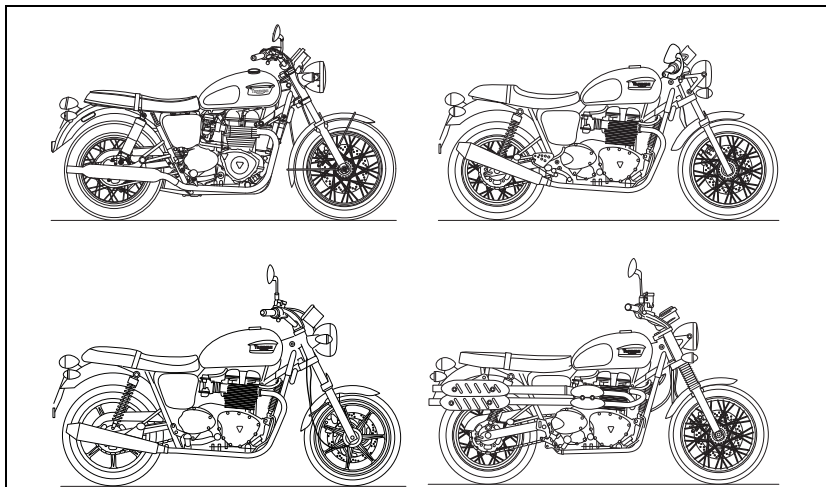

## Warnings, Cautions and Notes

Throughout this owner's handbook particularly important information is presented in the following form:

### **Warning**

This warning symbol identifies special instructions or procedures, which, if not correctly followed, could result in personal injury, or loss of life.

### **Caution**

This caution symbol identifies special instructions or procedures, which, if not strictly observed, could result in damage to, or destruction of, equipment.

### **Note:**

- **This note symbol indicates points of particular interest for more efficient and convenient operation.**

# Foreword

---

## Warning Labels

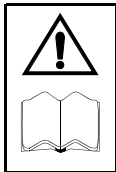

At certain areas of the motorcycle, the symbol (left) can be seen. The symbol means 'CAUTION: REFER TO THE HANDBOOK' and will be followed by a pictorial representation of the subject

concerned.

Never attempt to ride the motorcycle or make any adjustments without reference to the relevant instructions contained in this handbook.

See pages **12** to **13** for the location of all labels bearing this symbol. Where necessary, this symbol will also appear on the pages containing the relevant information.

## Maintenance

To ensure a long, safe and trouble free life for your motorcycle, maintenance should always be carried out by an authorized Triumph dealer.

Only an authorized Triumph dealer will have the necessary knowledge, equipment and skills to maintain your Triumph motorcycle correctly.

To locate your nearest Triumph dealer, visit the Triumph web-site at [www.triumph.co.uk](http://www.triumph.co.uk) or telephone Triumph Motorcycles America Limited on (678) 854 2010.

## Noise Control System

Tampering With the Noise Control System is Prohibited.

Owners are warned that the law may prohibit:

- a) The removal or rendering inoperative by any person other than for purposes of maintenance, repair or replacement, of any device or element of design incorporated into any new vehicle for the purpose of noise control prior to its sale or delivery to the ultimate purchaser or while it is in use and,
- b) the use of the vehicle after such device or element of design has been removed or rendered inoperative by any person.

## Owner's Handbook

Thank you for choosing a Triumph motorcycle. This motorcycle is the product of Triumph's use of proven engineering, exhaustive testing, and continuous striving for superior reliability, safety and performance.

Please read this owner's handbook before riding in order to become thoroughly familiar with the correct operation of your motorcycle's controls, its features, capabilities and limitations.

This handbook includes safe riding tips, but does not contain all the techniques and skills necessary to ride a motorcycle safely.

Triumph strongly recommends that all riders undertake a safety course approved by the Motorcycle Safety Foundation to ensure safe operation of this motorcycle. Information about the nearest Motorcycle Safety Foundation course to you can be obtained by calling the following nationwide toll free number: 800-447-4700, or by writing to the Motorcycle Safety Foundation at: 2, Jenner Street, Irvine, California 92718.

This handbook is also available from your local dealer in:

- Dutch;
- French;
- German;
- Italian;
- Japanese;
- Spanish;
- Swedish.

### **Warning**

This owner's handbook, and all other instructions that are supplied with your motorcycle, should be considered a permanent part of your motorcycle and should remain with it even if your motorcycle is subsequently sold.

All riders must read this owner's handbook and all other instructions which are supplied with your motorcycle, before riding, in order to become thoroughly familiar with the correct operation of your motorcycle's controls, its features, capabilities and limitations.

Do not lend your motorcycle to others as riding when not familiar with your motorcycle's controls, features, capabilities and limitations can lead to an accident.

## Information

The information contained in this publication is based on the latest information available at the time of printing. Triumph reserves the right to make changes at any time without prior notice, or obligation.

Not to be reproduced wholly or in part without the written permission of Triumph Motorcycles Limited.

© Copyright 08.2009 Triumph Motorcycles America Limited.

Publication part number 3856566 issue 3.

# Foreword

---

## Table of Contents

This handbook contains a number of different sections. The table of contents below will help you find the beginning of each section where, in the case of the major sections, a further table of contents will help you find the specific subject required.

Foreword . . . . .	1
Warning Labels . . . . .	12
Parts Identification . . . . .	14
Serial Numbers . . . . .	21
General Information . . . . .	23
How to Ride the Motorcycle . . . . .	45
Accessories, Loading and Passengers . . . . .	55
Maintenance and Adjustment . . . . .	59
Storage . . . . .	107
Specifications . . . . .	109

### FOREWORD - SAFETY FIRST

#### The Motorcycle

 **Warning**

This motorcycle is designed for on-road use only. It is not suitable for off-road use. Off-road operation could lead to loss of control of the motorcycle resulting in an accident causing injury or loss of life.

 **Warning**

This motorcycle is not designed to tow a trailer or be fitted with a sidecar. Fitting a sidecar and/or a trailer may result in loss of control and an accident.

 **Warning**

This motorcycle is designed for use as a two-wheeled vehicle capable of carrying a rider on his/her own, or a rider and one passenger (subject to a passenger seat being fitted).

The total weight of the rider, and any passenger, accessories and luggage must not exceed the maximum load limit of 440 lbs (200 kg).

# Foreword - Safety First

---

## Fuel and Exhaust Fumes

### **Warning**

#### **GASOLINE IS HIGHLY FLAMMABLE:**

Always turn off the engine when refuelling.

Do not refuel or open the fuel filler cap while smoking or in the vicinity of any open (naked) flame.

Take care not to spill any gasoline on the engine, exhaust pipes or mufflers when refuelling.

If gasoline is swallowed, inhaled or allowed to get into the eyes, seek immediate medical attention.

Spillage on the skin should be immediately washed off with soap and water and clothing contaminated with gasoline should immediately be removed.

Burns and other serious skin conditions may result from contact with gasoline.

### **Warning**

Never start your engine or let it run for any length of time in a closed area. The exhaust fumes are poisonous and may cause loss of consciousness and death within a short time. Always operate your motorcycle in the open-air or in an area with adequate ventilation.

### Riding

#### Warning

Never ride the motorcycle when fatigued or under the influence of alcohol or other drugs.

Riding when under the influence of alcohol or other drugs is illegal.

Riding when fatigued or under the influence of alcohol or other drugs reduces the rider's ability to maintain control of the motorcycle and may lead to loss of control and an accident.

#### Warning

All riders must be licensed to operate the motorcycle. Operation of the motorcycle without a license is illegal and could lead to prosecution.

Operation of the motorcycle without formal training in the correct riding techniques that are necessary to become licensed is dangerous and may lead to loss of motorcycle control and an accident.

#### Warning

Always ride defensively and wear the protective equipment mentioned elsewhere in this foreword. Remember, in an accident, a motorcycle does not give the same impact protection as a car.

#### Warning

This Triumph motorcycle should be operated within the legal speed limits for the particular road travelled.

Operating a motorcycle at high speeds can be potentially dangerous since the time available to react to given traffic situations is greatly reduced as road speed increases.

Always reduce speed in potentially hazardous driving conditions such as bad weather or heavy traffic.

#### Warning

Continually observe and react to changes in road surface, traffic and wind conditions. All two-wheeled vehicles are subject to external forces which may cause an accident. These forces include but are not limited to:

- Wind draft from passing vehicles;
- Potholes, uneven or damaged road surfaces;
- Bad weather;
- Rider error.

Always operate the motorcycle at moderate speed and away from heavy traffic until you have become thoroughly familiar with its handling and operating characteristics. Never exceed the legal speed limit.

## Foreword - Safety First

---

### **Warning**

Ensure that you know and respect the rules of the road. Read and observe publications such as 'MOTORCYCLE SAFETY', 'YOU AND YOUR MOTORCYCLE, RIDING TIPS' and also read and become familiar with the contents of the MOTORCYCLE HANDBOOK for your state.

### **Caution**

This Triumph motorcycle is not fitted with spark arresters. Operation in forests, brush or grass areas may violate state and local laws and regulations.

### **Wobble/Weave**

A weave is a relatively slow oscillation of the rear of the motorcycle, while a wobble is a rapid, possibly strong shaking of the handlebar. These are related but distinct stability problems usually caused by excessive weight in the wrong place, or by a mechanical problem such as worn or loose bearings or under-inflated or unevenly worn tires.

Your solution to both situations is the same. Keep a firm hold on the handlebars without locking arms or fighting the steering. Smoothly ease off the throttle to slow gradually. Do not apply the brakes, and do not accelerate to try to stop the wobble or weave. In some cases, it helps to shift your body weight forward by leaning over the tank.

Copyright © 2005 Motorcycle Safety Foundation. All rights reserved. Used with permission.

## Helmet and Clothing

### **Warning**

When riding the motorcycle, both rider and passenger must always wear a motorcycle helmet, eye protection, gloves, trousers (close fitting around the knee and ankle) and a brightly colored jacket. Brightly colored clothing will considerably increase a rider's (or passenger's) visibility to other operators of road vehicles. Although full protection is not possible, wearing correct protective clothing can reduce the risk of injury when riding.



## Warning

A helmet is one of the most important pieces of riding gear as it offers protection against head injuries. You and your passenger's helmet should be carefully chosen and should fit you or your passenger's head comfortably and securely. A brightly colored helmet will increase a rider's (or passenger's) visibility to other operators of road vehicles.

An open face helmet offers some protection in an accident though a full face helmet will offer more.

Always wear a visor or approved goggles to help vision and to protect your eyes.



cbma

When choosing a helmet, always look for a DOT (Department of Transport) sticker indicating that the helmet has DOT approval. Do not buy a helmet without DOT approval.

## Handlebars and Footrests

### Warning

The rider must maintain control of the vehicle by keeping hands on the handlebars at all times.

The handling and stability of a motorcycle will be adversely affected if the rider removes his hands from the handlebars, resulting in loss of control or an accident.

### Warning

Footrests provided must always be used by the rider and passenger during operation of the vehicle.

By using the footrests, both rider and passenger will reduce the risk of inadvertent contact with any motorcycle components and will also reduce the risk of injury from entrapment of clothing.

# Foreword - Safety First

---

## Parking

### Warning

Always turn off the engine and remove the ignition key before leaving the motorcycle unattended. By removing the key, the risk of use of the motorcycle by unauthorized or untrained persons is reduced.

When parking the motorcycle, always remember the following:

Engage first gear to help prevent the motorcycle from rolling off the stand.

The engine and exhaust system will be hot after riding. DO NOT park where pedestrians, animals and/or children are likely to touch the motorcycle.

Do not park on soft ground or on a steeply inclined surface. Parking under these conditions may cause the motorcycle to fall over.

For further details, please refer to the 'How to Ride the Motorcycle' section of this owner's handbook.

## Parts and Accessories

### Warning

Owners should be aware that the only approved parts, accessories and conversions for any Triumph motorcycle are those which carry official Triumph approval and are fitted to the motorcycle by an authorized dealer.

In particular, it is extremely hazardous to fit or replace parts or accessories whose fitting requires the dismantling of, or addition to, either the electrical or fuel systems and any such modification could cause a safety hazard.

The fitting of any non-approved parts, accessories or conversions may adversely affect the handling, stability or other aspect of the motorcycle operation that may result in an accident causing injury or death.

Triumph does not accept any liability whatsoever for defects caused by the fitting of non-approved parts, accessories or conversions or the fitting of any approved parts, accessories or conversions by non-approved personnel.

### Maintenance/Equipment

#### **Warning**

Consult your authorized Triumph dealer whenever there is doubt as to the correct or safe operation of this Triumph motorcycle.

Remember that continued operation of an incorrectly performing motorcycle may aggravate a fault and may also compromise safety.

#### **Warning**

Use of a motorcycle with bank angle indicators worn beyond the maximum limit (when 0.40 in (10 mm) or more of the radiused tip of either front footrest is worn away) will allow the motorcycle to be banked to an unsafe angle.

Never change the setting of the brake pedal adjustment pushrod as this may adversely affect the bank angle at which the bank angle indicators contact the ground.

Banking to an unsafe angle may cause instability, loss of control and an accident causing injury or death.

#### **Warning**

Ensure all equipment that is required by law is installed and functioning correctly.

The removal or alteration of the motorcycle's lights, mufflers, emission or noise control systems can violate the law.

Incorrect or improper modification may adversely affect the handling, stability or other aspect of the motorcycle operation, which may result in an accident causing injury or death.

#### **Warning**

If the motorcycle is involved in an accident, collision or fall, it must be taken to an authorized Triumph dealer for inspection and repair. Any accident can cause damage to the motorcycle that, if not correctly repaired, may cause a second accident that may result in injury or death.

# Warning Labels

## WARNING LABELS

### Warning Label Locations

The labels detailed on this and the following pages draw your attention to important safety information in this handbook. Before riding, ensure that all riders have understood and complied with all the information to which these labels relate.

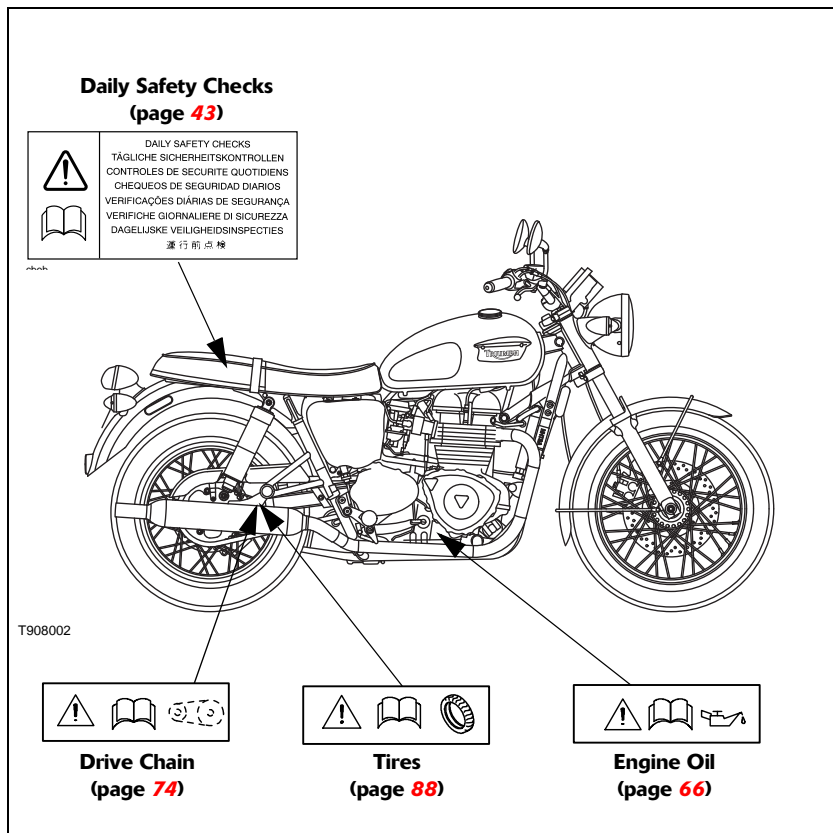

## Warning Label Locations (continued)

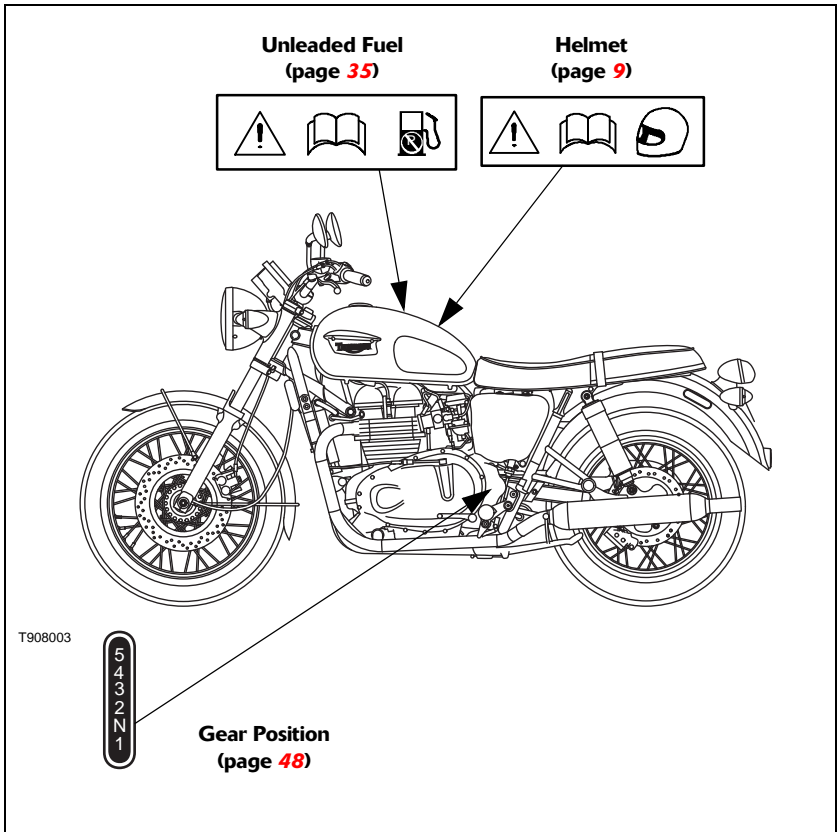

## Parts Identification

### PARTS IDENTIFICATION

#### Parts Identification - Bonneville, Bonneville SE and Bonneville T100 (Bonneville T100 shown)

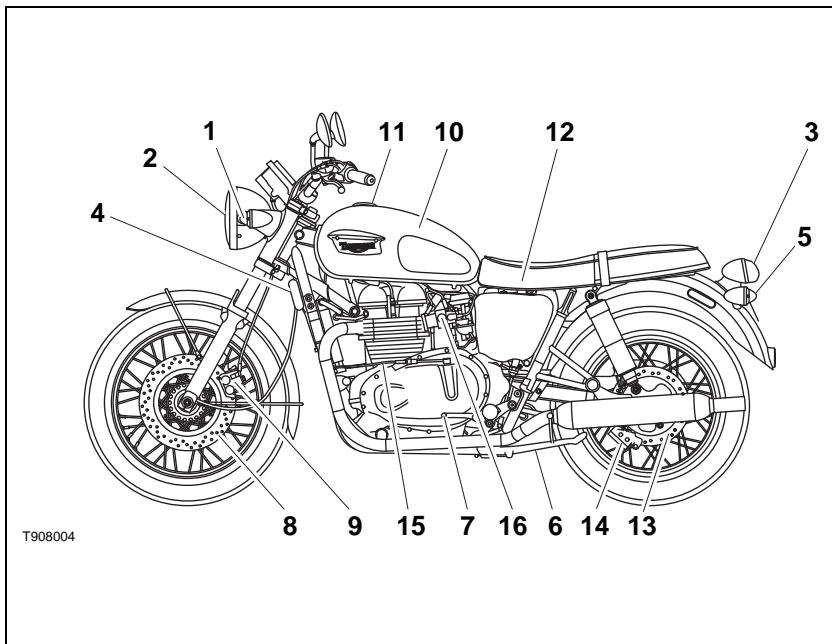

1. Front turn signal
2. Headlight
3. Brake/Tail light
4. Oil cooler
5. Rear turn signal
6. Side stand
7. Gearshift pedal
8. Front brake disc

9. Front brake caliper
10. Fuel tank
11. Fuel filler cap
12. Battery
13. Rear brake disc
14. Rear brake caliper
15. Clutch cable
16. Choke control



# Parts Identification

## Parts Identification -Thruxton

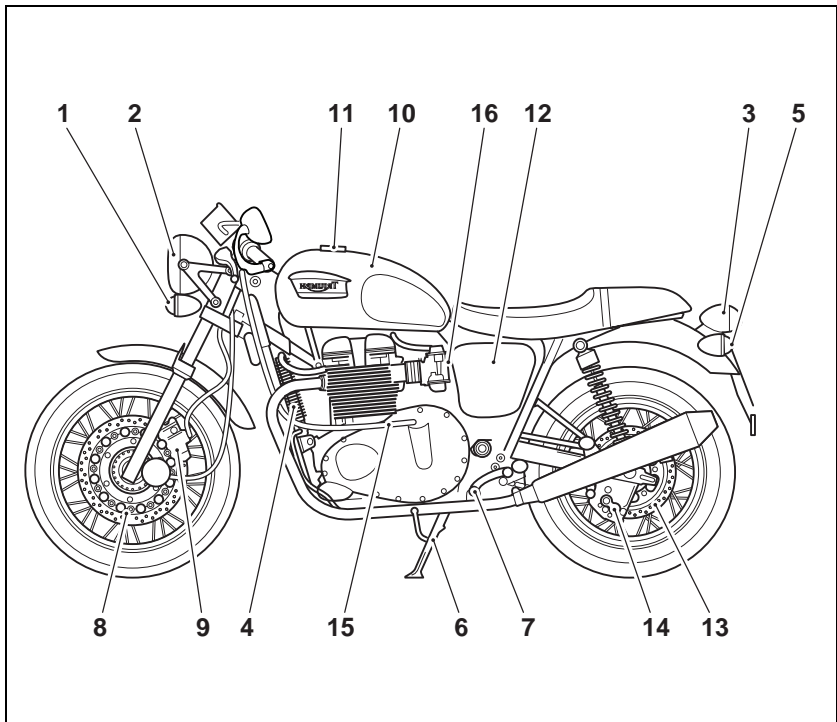

- 1. Front turn signal
- 2. Headlight
- 3. Brake/Tail light
- 4. Oil cooler
- 5. Rear turn signal
- 6. Side stand
- 7. Gearshift pedal
- 8. Front brake disc

- 9. Front brake caliper
- 10. Fuel tank
- 11. Fuel filler cap
- 12. Battery
- 13. Rear brake disc
- 14. Rear brake caliper
- 15. Clutch cable
- 16. Choke control



## Parts Identification - Thruxton (continued)

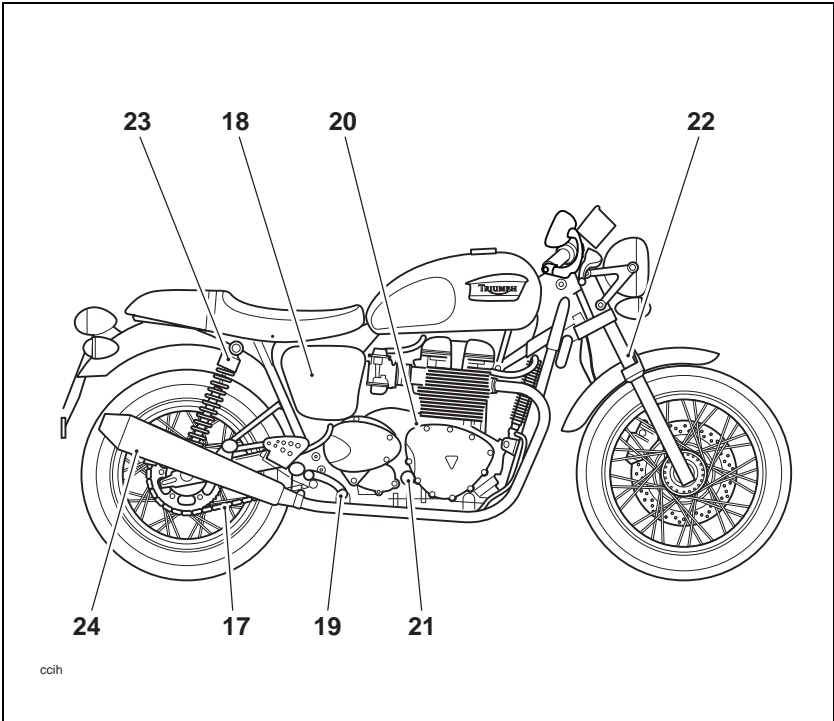

- 17. Drive chain
- 18. Rear brake fluid reservoir
- 19. Rear brake pedal
- 20. Oil filler plug

- 21. Oil level sight glass
- 22. Front fork
- 23. Rear suspension unit
- 24. Muffler

# Parts Identification

## Parts Identification - Scrambler

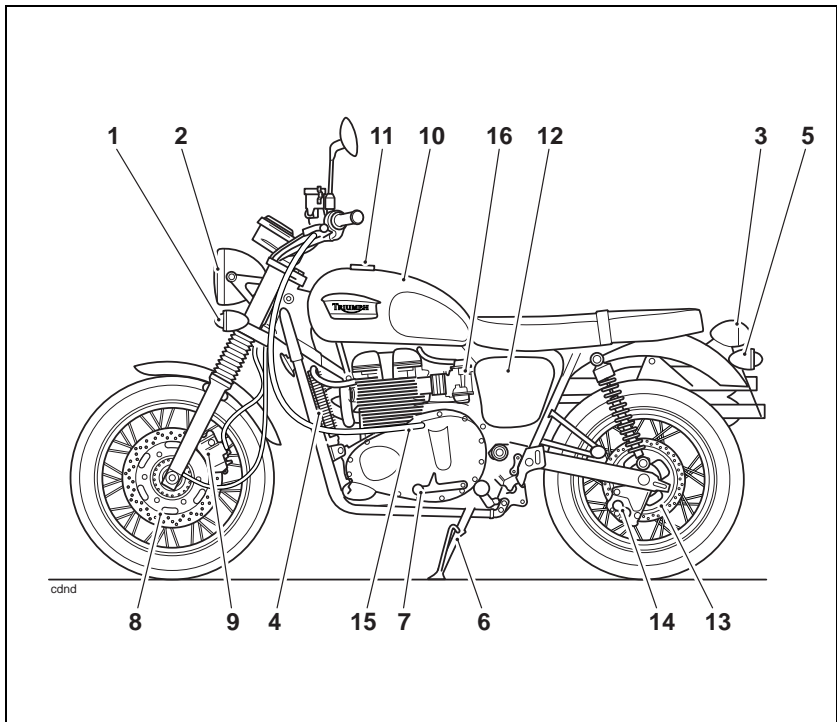

- 1. Front turn signal
- 2. Headlight
- 3. Brake/Tail light
- 4. Oil cooler
- 5. Rear turn signal
- 6. Side stand
- 7. Gearshift pedal
- 8. Front brake disc

- 9. Front brake caliper
- 10. Fuel tank
- 11. Fuel filler cap
- 12. Battery
- 13. Rear brake disc
- 14. Rear brake caliper
- 15. Clutch cable
- 16. Choke control

# Parts Identification

## Parts Identification - Scrambler (continued)

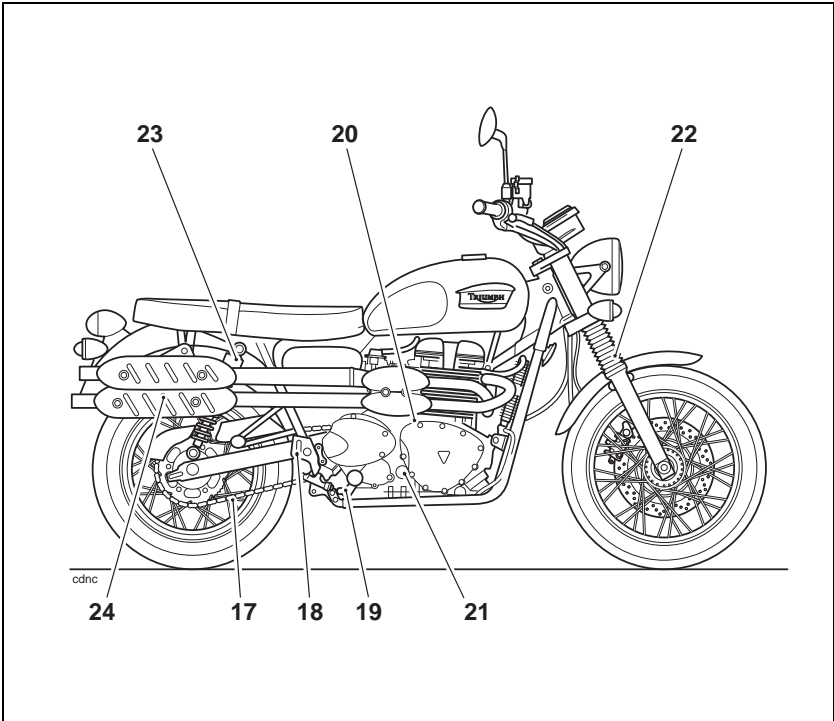

- 17. Drive chain
- 18. Rear brake fluid reservoir
- 19. Rear brake pedal
- 20. Oil filler plug

- 21. Oil level sight glass
- 22. Front fork
- 23. Rear suspension unit
- 24. Muffler

# Parts Identification

## Parts Identification - All Models

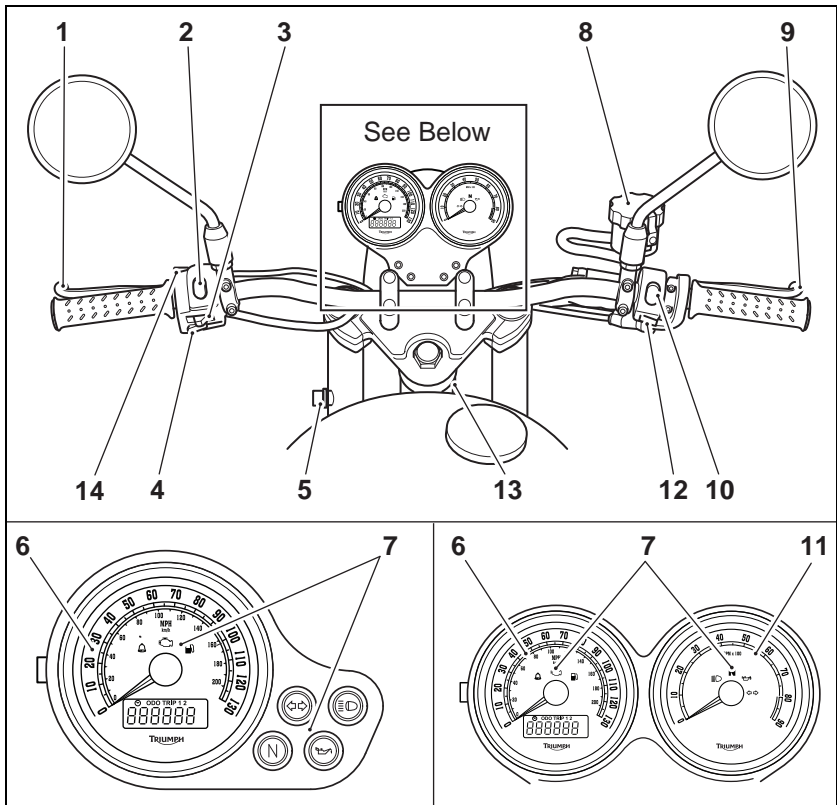

- 1. Clutch lever
- 2. Headlight dimmer switch
- 3. Turn signal switch
- 4. Horn button
- 5. Ignition switch
- 6. Speedometer
- 7. Warning lights
- 8. Front brake fluid reservoir

- 9. Front brake lever
- 10. Engine stop switch
- 11. Tachometer (Thruxton, Scrambler, Bonneville SE and Bonneville T100 only)
- 12. Starter button
- 13. Steering lock
- 14. Passing switch (Thruxton and Scrambler only)

## SERIAL NUMBERS

### Vehicle Identification Number (VIN)

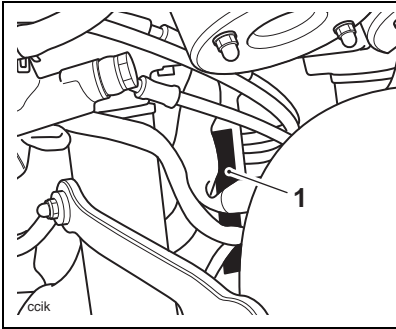

#### 1. VIN number stamping

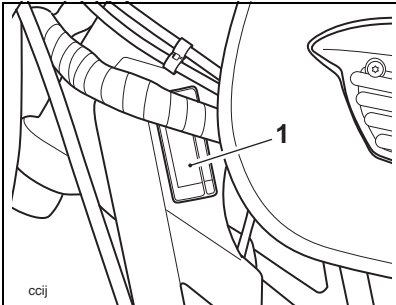

#### 1. VIN plate location

The vehicle identification number is stamped into the steering head.

In addition, it is displayed on a label which is also adjacent to the steering head.

### Engine Serial Number

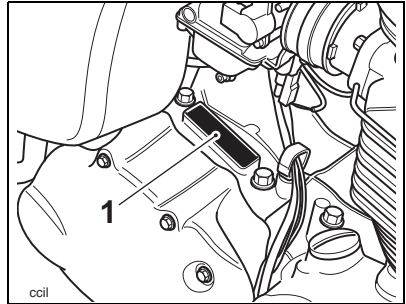

#### 1. Engine serial number

The engine serial number is stamped on the crankcase, immediately above the drive chain sprocket cover.

Record the vehicle identification number in the space below.

Record the engine serial number in the space below.

## Serial Numbers

---

This page intentionally left blank

## GENERAL INFORMATION

### Table of Contents

Instruments .....	25
Speedometer .....	26
Odometer/Trip Meter .....	26
Trip Meter Reset .....	26
Clock Adjustment .....	27
Tachometer (where fitted) .....	27
Warning Lights .....	28
Turn Signals .....	28
High Beam .....	28
Neutral .....	28
Engine Management System Malfunction Indicator Light .....	28
Low Fuel .....	28
Low Oil Pressure .....	28
Ignition Key .....	29
Ignition Switch .....	30
Switch Location .....	30
Switch Operation .....	30
Ignition Switch Positions .....	30
Steering Lock Key .....	31
Steering Lock .....	31
Right Handlebar Switches .....	32
Engine Stop Switch .....	32
Starter Button .....	32
Left Handlebar Switches .....	33
Headlight Dimmer Switch .....	33
Turn Signal Switch .....	33
Horn Button .....	33
Pass Button .....	33

## General Information

---

Brake and Clutch Lever Adjusters .....	34
Heat Shield (Thruyton only) .....	35
Fuel .....	35
Fuel Grade .....	35
Oxygenated Gasoline .....	36
Ethanol .....	36
MTBE (Methyl Tertiary Butyl Ether) .....	36
Methanol .....	36
Refuelling .....	37
Fuel Tank Cap .....	37
Filling The Fuel Tank .....	38
Side Cover (Bonneville, Bonneville SE, Bonneville T100 and Thruyton models) .....	39
Right Hand Side Cover (Scrambler only) .....	39
Left Hand Side Cover (Scrambler only) .....	40
Seat .....	40
Seat Care .....	41
Stand .....	41
Side Stand .....	41
Owner's Handbook .....	42
Breaking-In .....	42
Safe Operation .....	43
Daily Safety Checks .....	43



## Instruments

### Bonneville

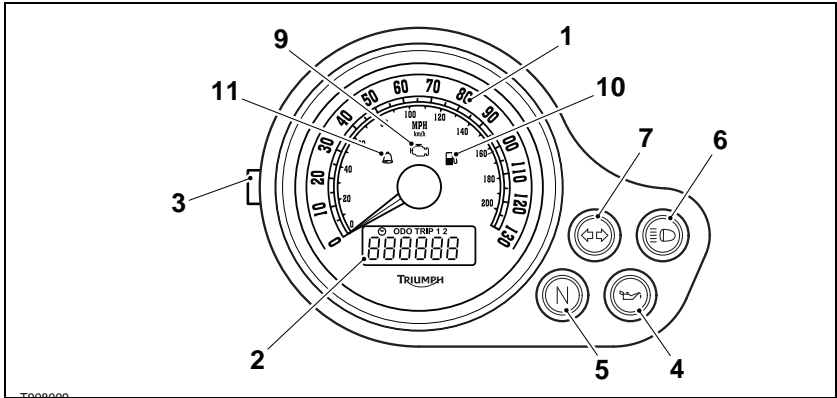

### Bonneville SE, Bonneville T100, Scrambler and Thruxton

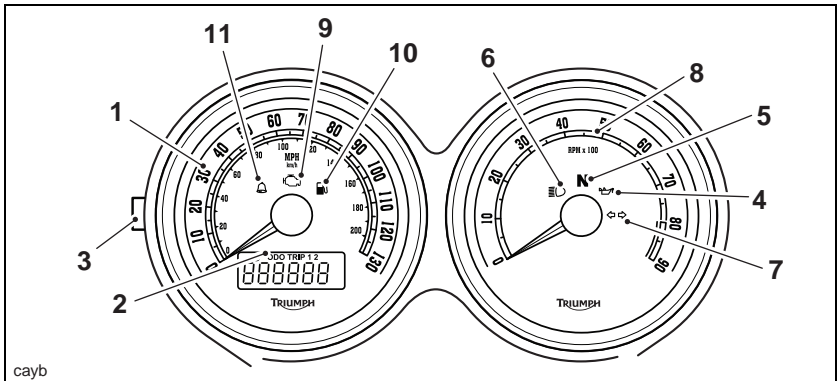

1. Speedometer

2. Odometer

3. Reset button

4. Low oil pressure warning light

5. Neutral indicator light

6. High beam indicator light

7. Turn signal indicator light

8. Tachometer location (Bonneville SE,

Bonneville T100, Scrambler and Thruxton)

9. Engine management malfunction indicator light (MIL)

10. Low fuel level indicator light

11. Alarm status indicator light (alarm is an accessory fit)

## General Information

### Speedometer

The speedometer indicates the road speed of the motorcycle.

### Odometer/Trip Meter

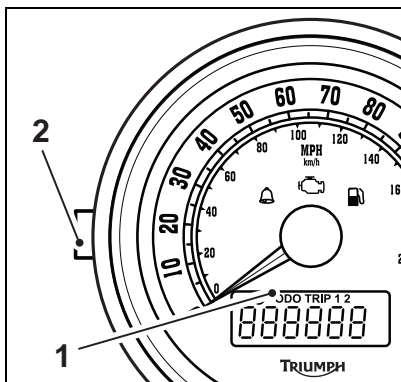

1. Odometer/trip meter/clock display
2. Reset button

The odometer shows the total distance that the motorcycle has travelled.

There are two trip meters. Either trip meter shows the distance that the motorcycle has travelled since the meter on display was last reset to zero.

### Warning

Do not attempt to switch between odometer and trip meter display modes or reset the trip meter with the motorcycle in motion as this may lead to loss of motorcycle control and an accident.

To switch between the odometer and trip meter display modes, press and release the reset button until the desired display is visible. The display will scroll through in the order:

- Odometer
- Trip meter 1
- Trip meter 2
- Clock

### Trip Meter Reset

To reset either of the trip meters, select and display the trip meter to be zeroed then press the reset button for 2 seconds. After 2 seconds, the trip meter on display will reset to zero.

## Clock Adjustment

### Warning

Do not attempt to adjust the clock with the motorcycle in motion as this may lead to loss of motorcycle control and an accident.

To set the clock, turn the ignition to the ON position. Press and release the reset button until the clock is visible in the display screen.

Press and hold the reset button for 4 seconds. After 4 seconds either 24 Hr or 12 Hr will be shown flashing. Press and release the reset button to select the desired clock display. When the correct display is shown, do not touch the reset button until the clock is shown with the hour display flashing.

To reset the hour display, ensure that the hour display is still flashing. Press the reset button to change the setting. Each individual button press will change the setting by one digit. If the button is held, the display will continuously scroll through in single digit increments.

When the correct hour display is shown, do not touch the reset button for 6 seconds. The minutes display will begin to flash automatically. The minutes display is adjusted in the same way as for the hours.

Once both hours and minutes are correctly set, do not touch the reset button for

6 seconds and the display will cease to flash automatically.

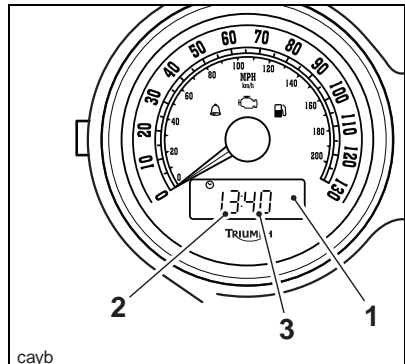

1. Clock display
2. Hours read-out
3. Minutes read-out

### Tachometer (where fitted)

The tachometer shows the engine speed in revolutions per minute - rpm (r/min). On the right side of the tachometer face is the 'red zone'. Engine rpm (r/min) in the red zone is above maximum recommended engine speed and is also above the range for best performance.

### Caution

Never allow engine rpm to enter the 'red zone' as severe engine damage may result.

# General Information

## Warning Lights



### Turn Signals

When the direction indicators are switched on, the direction indicator warning light will flash on and off at the same speed.



### High Beam

When the headlights are switched on and the headlight dimmer switch is set to 'high beam', the high beam warning light will illuminate.



### Neutral

The neutral indicator light indicates when the transmission is in neutral (no gear selected). The indicator light will illuminate when the transmission is in neutral with the ignition switch in the ON position.



### Engine Management System Malfunction Indicator Light

The malfunction indicator light for the engine management system illuminates when the ignition is switched on (to indicate that it is working) but should not become illuminated when the engine is running.

If the malfunction indicator light becomes illuminated when the engine is running, this indicates that a fault has occurred in one or more of the systems controlled by the engine management system. In such circumstances, the engine management system will switch to 'limp-home' mode so that the journey may be completed, if the fault is not so severe that the engine will not run.



## Warning

Reduce speed and do not continue to ride for longer than is necessary with the malfunction indicator light illuminated. The fault may adversely affect engine performance, exhaust emissions and fuel consumption. Reduced engine performance could cause a dangerous riding condition, leading to loss of control and an accident. Contact an authorized Triumph dealer as soon as possible to have the fault checked and rectified.

### Note:

- **If the malfunction indicator light flashes when the ignition is switched on, contact an authorized Triumph dealer as soon as possible to have the situation rectified. In these circumstances the engine will not start.**



### Low Fuel

The low fuel indicator will illuminate when there is approximately 0.92 US gal (3.5 liters) of fuel remaining in the tank.



### Low Oil Pressure

The low oil pressure warning light becomes illuminated whenever the oil pressure is dangerously low (or the ignition switch is in the ON position with the engine not running). When the engine is running, the light will remain off when sufficient oil pressure is present.

When starting the motorcycle, check that the light comes on when the ignition is in the

ON position, but goes out as soon as the engine starts.

## **Caution**

Stop the engine immediately if the low oil pressure warning light illuminates. Do not restart the engine until the fault has been rectified.

Severe engine damage will result from running the engine when the low oil pressure warning light is illuminated.

## Ignition Key

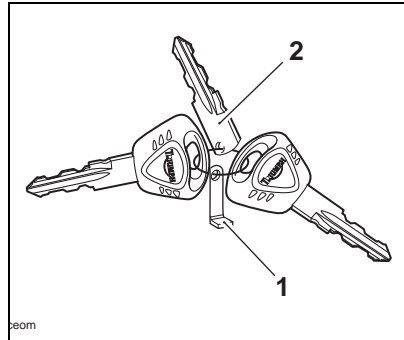

1. Key number tag
2. Spare key blade

The ignition key operates the ignition switch only. A different key operates the steering lock.

When the motorcycle is delivered from the factory, two ignition keys are supplied together with a small tag bearing the key number, and a spare key blade for use with Triumph accessory alarm. Make a note of the key number and store the spare key, key blade and key number tag in a safe place away from the motorcycle.

Your authorized Triumph dealer can supply a replacement key cut from details of the key number or can cut a new key using the original as a master.

## **Caution**

Do not store the spare key with the motorcycle as this will reduce all aspects of security.

# General Information

## Ignition Switch

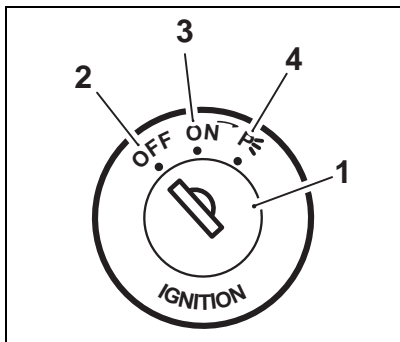

1. Ignition switch
2. OFF position
3. ON position
4. P (PARK) position

### Switch Location

The ignition switch is located on the headlight support bracket on the left hand side of the motorcycle.

### Switch Operation

This is a three position, key operated switch. The key can be removed from the switch only when it is in the OFF or P (PARK) positions.

To turn the switch from OFF to ON, insert the key and turn the key clockwise to the ON position.

To turn the switch from ON to PARK, push the key barrel further into the lock and turn clockwise to the PARK position. Use the PARK position only when temporarily leaving the motorcycle in a situation where the position lights must remain on.

To turn the key back to OFF, turn the key counter-clockwise.

## Ignition Switch Positions

OFF	Engine off. All electrical circuits off.
ON	Engine on. All electrical equipment can be used.
P	Engine off. Tail, side and license plate lights on, all other electrical circuits cut off.

### Warning

For reasons of security and safety, always turn the ignition to the OFF or PARK position and remove the key when leaving the motorcycle unattended.

Any unauthorized use of the motorcycle may cause injury to the user, other road users and pedestrians and may also cause damage to the motorcycle.

### Note:

- **Do not leave the ignition switch in the P position for long periods as this will cause the battery to discharge.**

## Steering Lock Key

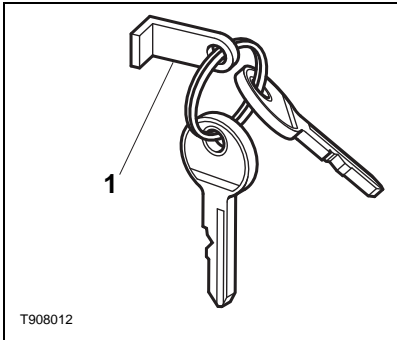

### 1. Steering lock key tag

The steering lock key operates the steering lock only. A different key operates the ignition switch.

When the motorcycle is delivered from the factory, two steering lock keys are supplied together with a small tag bearing the key number. Make a note of the key number and store the spare key and key number tag in a safe place away from the motorcycle.

Your authorized Triumph dealer can supply a replacement key cut from details of the key number or can cut a new key using the original as a master.

### Caution

Do not store the spare key with the motorcycle as this will reduce all aspects of security.

## Steering Lock

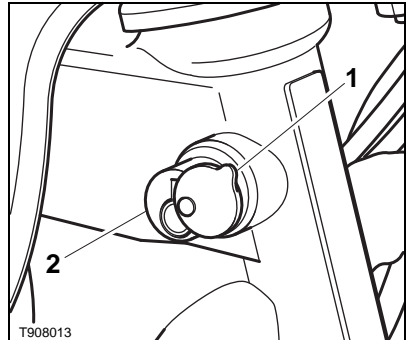

### 1. Steering lock cover

### 2. Steering lock

This is a two position, key operated lock. The key can be removed in either the engaged or disengaged positions.

To engage the lock, insert the key and push the complete lock inwards while turning counter-clockwise. At the same time turn the handlebars fully left until the lock engages (at which point the lock will turn and move inwards).

To disengage the steering lock, insert the key, turn the handlebars slightly to relieve any weight on the lock and turn the key further counter-clockwise until the lock springs outwards. Remove the key.

### Warning

Always disengage the steering lock before riding as, with the steering lock engaged, it will not be possible to turn the handlebars or steer the motorcycle.

Riding without motorcycle steering control will lead to loss of control and an accident.

# General Information

## Right Handlebar Switches

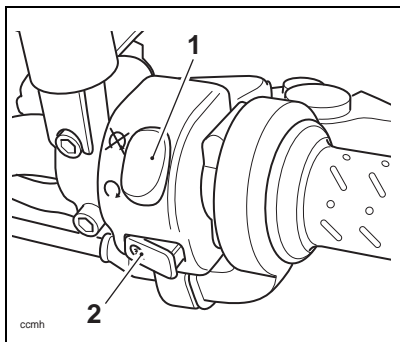

1. Engine stop switch (Scrambler shown)
2. Starter button



### Engine Stop Switch

In addition to the ignition switch being turned to the ON position, the engine stop switch must be in the RUN position for the motorcycle to operate.

The engine stop switch is for emergency use. If an emergency arises which requires the engine to be stopped, move the engine stop switch to the STOP position.

#### Note:

- **Although the engine stop switch stops the engine, it does not turn off all the electrical circuits. Ordinarily, the ignition switch should be used to stop the engine.**



### Caution

Do not leave the ignition switch in the ON position unless the engine is running as this may cause damage to electrical components and the battery.



### Starter Button

The starter button operates the electric starter. For the starter to operate, the clutch lever must be pulled to the handlebar.

#### Note:

- **Even if the clutch lever is pulled to the handlebar, the starter will not operate if the side stand is down and a gear is engaged.**
- **Light switches are no longer fitted to any Triumph model. Instead, the head and tail lights automatically come on when the ignition is in the ON position.**



## Left Handlebar Switches

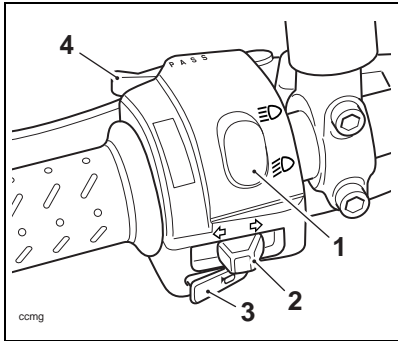

1. **Headlight dimmer switch**
2. **Turn signal switch**
3. **Horn button**
4. **Passing button (Bonneville, Bonneville SE and Scrambler models only)**



### Headlight Dimmer Switch

High or low beam can be selected with the headlight dimmer switch.

To select high beam, push the switch forward.  
To select low beam, push the switch rearwards. When the high beam is turned on, the high beam warning light will illuminate.



### Turn Signal Switch

When the turn signal switch is pushed to the left or the right and released, the corresponding turn signal flashes. To turn off the turn signals, push and release the button in the center of the switch.



### Horn Button

When the horn button is pushed, with the ignition switch turned to the ON position, the horn will sound.



### Pass Button

When the pass button is pressed, the headlight main beam will be switched on. It will remain on as long as the button is held in and will turn off as soon as the button is released.

# General Information

## Brake and Clutch Lever Adjusters

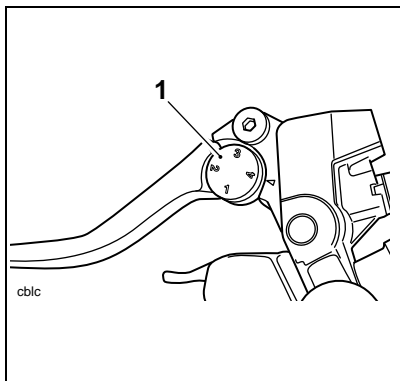

### 1. Lever adjuster wheel

An adjuster is fitted to the front brake and clutch levers (all models except on Bonneville T100 and Thruxton). The adjusters allow the distance from the handlebar to the lever to be changed to one of four positions, to suit the span of the operator's hands.

To adjust a lever, push the lever forward and turn the adjuster wheel to align one of the numbered positions with the triangular mark on the lever pivot (seen aligned with position 4 above).

The distance from the hand grip to the released lever is shortest when set to number four and longest when set to number one.

### **Warning**

Do not attempt to adjust the levers with the motorcycle in motion as this may lead to loss of control and an accident.

After adjusting the levers, operate the motorcycle in an area free from traffic to gain familiarity with the new lever settings. Do not loan your motorcycle to anyone as they may change the lever settings from the one you are familiar with possibly causing loss of control or an accident.

## Heat Shield (Thruxton only)

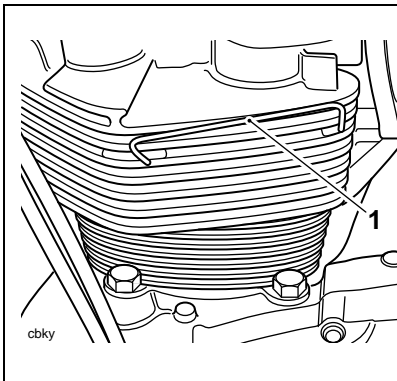

### 1. Heat shield

Heat shields are fitted to the cylinder head, on both sides of the motorcycle. The shields are fitted in order to protect the rider's knee from potential contact with the cylinder head which will be hot whenever the engine is running and for a period afterwards.

### Warning

Never remove the heat shields from the cylinder head and always repair or replace the heat shields if they become damaged or detached.

Removal of either heat shield may lead to contact of the rider's leg with hot engine parts. Contact with hot engine parts may lead to burns and other skin damage.

## Fuel



### Fuel Grade

This Triumph motorcycle is designed to run on unleaded gasoline with a CLC or AKI octane rating  $(R+M)/2$  of 87 or higher. Federal regulations require that pumps delivering unleaded gasoline are marked 'UNLEADED' and that the Cost of Living Council (CLO) or Anti-Knock Index (AKI) octane rating is also displayed. These ratings are an average of the Research Octane Number (RON) and the Motor Octane Number (MON).

### Caution

The exhaust system is fitted with a catalytic converter to help reduce exhaust emission levels. The catalytic converter can be permanently damaged if the motorcycle is allowed to run out of fuel or if the fuel level is allowed to get very low. Always ensure you have adequate fuel for your journey.

### Caution

The use of leaded gasoline is illegal in some countries, states or territories. Use of leaded fuel will damage the catalytic converter.

## General Information

---

### Note:

- If 'knocking' or 'pinging' occurs at a steady engine speed under normal load, use a different brand of gasoline or gasoline which has a higher octane rating.

### Oxygenated Gasoline

To help in meeting clean air standards, some areas of the U.S. use oxygenated gasoline to help reduce harmful emissions. These gasolines are a blend of conventional gasoline and another compound such as alcohol. This Triumph motorcycle will give its best performance when using unleaded gasoline. However, the following should be used as a guide if you use any oxygenated fuels.

### Ethanol

Ethanol fuel is a mixture of 10% Ethanol and 90% gasoline and is often described under the names 'gasohol', 'Ethanol enhanced', or 'contains Ethanol'. This fuel may be used in your Triumph motorcycle.

### MTBE (Methyl Tertiary Butyl Ether)

The use of gasolines containing up to 15% MTBE (Methyl Tertiary Butyl Ether) is permitted in this Triumph motorcycle.

### Methanol



Fuels containing methanol should not be used as damage to components in the fuel system can be caused by contact with methanol.



Because of the generally higher volatility of oxygenated fuels, starting, engine response and fuel consumption may be adversely affected by their use. Should any of these difficulties be experienced, run the motorcycle on normal unleaded gasoline.

## Refuelling

### Warning

To help reduce hazards associated with fuel handling, always observe the following fuel safety instructions:

Gasoline (fuel) is highly flammable and can be explosive under certain conditions. When refuelling, turn the ignition switch to the OFF position.

Do not smoke.

Do not use a mobile telephone.

Make sure the refuelling area is well ventilated and free from any source of flame or sparks. This includes any appliance with a pilot light.

Never fill the tank such that fuel level rises into the filler neck. Heat from sunlight or other sources may cause the fuel to expand and overflow creating a fire hazard.

After refuelling always check that the fuel filler cap is correctly closed.

Because gasoline (fuel) is highly flammable, any fuel leak or spillage, or any failure to observe the safety advice given above will lead to a fire hazard which could cause damage to property, injury to persons or death.

## Fuel Tank Cap

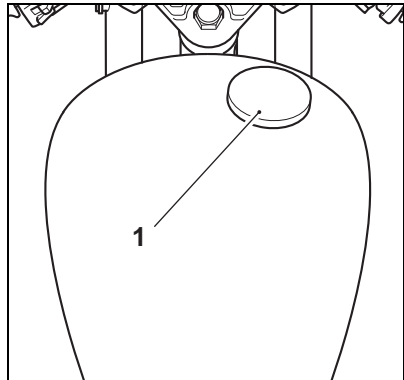

### 1. Fuel tank cap

To open the fuel tank cap, rotate the cap counter-clockwise and lift clear of the tank filler neck.

To close the cap, align the cap to the tank filler neck and rotate the cap clockwise until the cap seals against the filler neck. In the fully closed position, a ratchet mechanism prevents over-tightening of the cap by allowing the outer part of the cap to turn independently of the internal part.

## General Information

### Filling The Fuel Tank

Avoid filling the tank in rainy or dusty conditions where airborne material can contaminate the fuel.

#### **Caution**

Contaminated fuel may cause damage to fuel system components.

Fill the fuel tank slowly to help prevent spillage. Do not fill the tank to a level above the bottom of the filler neck. This will ensure there is enough air space to allow for fuel expansion if the fuel inside the tank expands through absorption of heat from the engine or from direct sunlight.

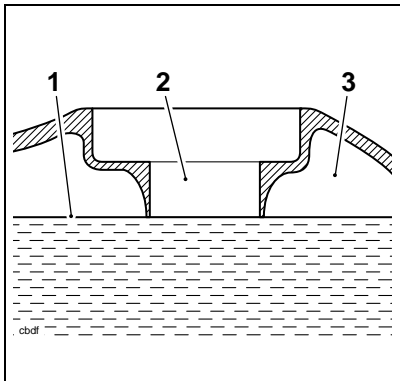

1. **Fuel level**
2. **Filler neck**
3. **Air space**

After refuelling always check that the fuel filler cap is correctly closed and locked.

#### **Warning**

Overfilling the tank can lead to fuel spillage.

If gasoline (fuel) is spilled, thoroughly wipe off the spilled fuel immediately and dispose of the cleaning cloth safely.

Take care not to spill any gasoline (fuel) on the engine, exhaust pipes, tires or any other part of the motorcycle.

Because gasoline (fuel) is highly flammable, any fuel leak or spillage, or any failure to observe the safety advice given above will lead to a fire hazard which could cause damage to property, injury to persons or death.

Gasoline (fuel) spilled near to or on the tires will reduce the tire's ability to grip the road. This will result in a dangerous riding condition causing loss of motorcycle control and an accident.

### Side Cover (Bonneville, Bonneville SE, Bonneville T100 and Thruxton models)

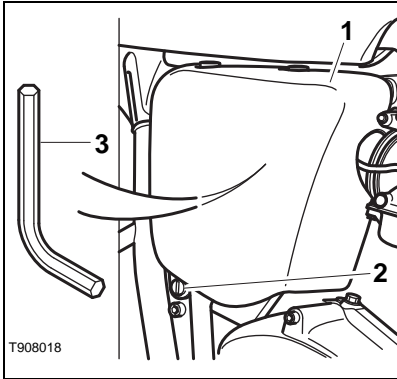

1. Side cover
2. Fastener
3. Seat removal tool

The right hand side cover can be removed to gain access to the fuse box, seat removal tool, rear brake fluid reservoir etc.

To remove the side cover, release the cover's threaded fastener using a coin.

Lift the cover until it clears its retaining dowels and then remove the cover from the motorcycle.

To install, position the cover over its locating dowels, install the threaded fastener and tighten with a coin.

Finally, grasp the cover and ensure that it is fully retained.

### Right Hand Side Cover (Scrambler only)

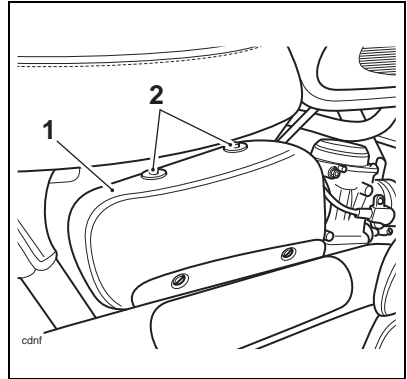

1. Side cover
2. Retaining dowels/grommets

The right hand side cover can be removed to gain access to the fuse box.

To remove the side cover, pull the top of the cover away from the motorcycle until it clears its retaining dowels (leaving the grommets in place) and then lift up and remove the cover from the motorcycle.

To install, position the lower locating dowels, then press firmly to secure the cover into the upper grommets.

Ensure the cover is correctly located over the upper and lower locating dowels.

Finally, grasp the cover and ensure that it is fully retained.

## General Information

### Left Hand Side Cover (Scrambler only)

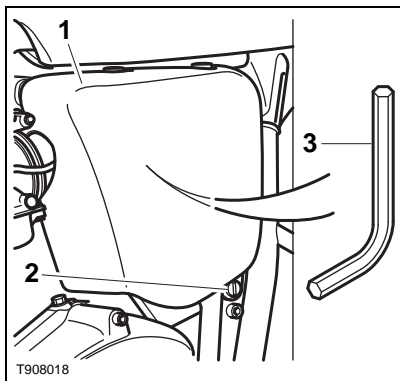

1. Side cover
2. Fastener
3. Seat removal tool

The left hand side cover can be removed to gain access to the seat removal tool.

To remove the side cover, release the cover's threaded fastener using a coin.

Lift the cover until it clears its retaining dowels and then remove the cover from the motorcycle.

To install, position the cover over its locating dowels, install the threaded fastener and tighten with a coin.

Finally, grasp the cover and ensure that it is fully retained.

### Seat

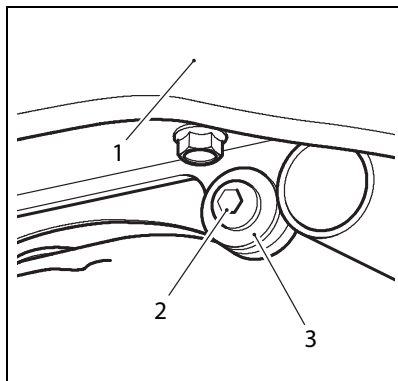

1. Seat
2. Fastener (right hand shown)
3. Stepped sleeve

The seat can be removed to gain access to the battery, owner's handbook etc. An Allen key, located beneath the right hand side panel on Bonneville, Bonneville SE, Bonneville T100 and Thruxton models, and beneath the left hand side panel on Scrambler, is provided to allow removal of the seat fasteners.

To locate the Allen key, remove the right hand side cover (left hand side cover on Scrambler) as described earlier in this section. On Bonneville, Bonneville SE, Bonneville T100 and Thruxton models, the Allen key is located in a retainer, beneath the fuse box. On Scrambler models, the Allen key is located in a retainer between the two rearmost relays.

Remove the fasteners from the rear of the seat, collecting the stepped sleeves, and lift the seat clear of the frame.



## Seat Care

To prevent damage to the seat or seat cover, care must be taken not to drop or lean the seat against any surface which may damage the seat or seat cover.

### **Caution**

To prevent damage to the seat or seat cover, care must be taken not to drop the seat. Do not lean the seat against the motorcycle or any surface which may damage the seat or seat cover. Instead, place the seat, with the seat cover facing upwards, on a clean, flat surface which is covered with a soft cloth.

Do not place any item on the seat which may cause damage or staining to the seat cover.

To install, locate the seat to the frame ensuring the locating tongue is correctly positioned beneath the fuel tank bridge.

Finally, install the stepped sleeves, and tighten the seat retaining screws.

Store the Allen key in the space provided and install the right/left hand side cover.

## Stand

### Side Stand

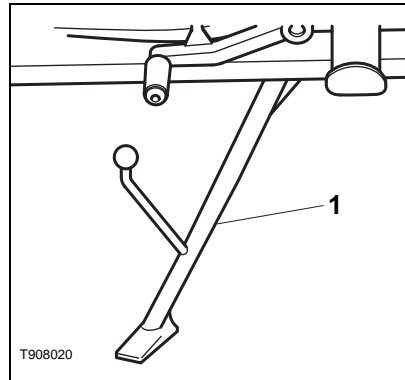

#### 1. Side stand

The motorcycle is equipped with a side stand on which the motorcycle can be parked.

Whenever the stand is used, before riding, always ensure that the stand is fully up after first sitting on the motorcycle.

For instructions on safe parking, refer to the 'How to Ride the Motorcycle' section.

### **Warning**

The motorcycle is fitted with an interlock system to prevent it from being ridden with the side stand in the down position.

Never attempt to ride with the side stand down or interfere with the interlock mechanism as this will cause a dangerous riding condition leading to loss of motorcycle control and an accident.

## General Information

---

### Note:

- **When using the side stand, always turn the handlebars fully to the left and leave the motorcycle in first gear.**

### Owner's Handbook

The motorcycle owner's handbook is stored in the space between the rear mudguard and the seat.

Access to the handbook can be gained by removing the seat.

### Breaking-In

Breaking-in is the name given to the process that occurs during the first hours of a new vehicle's operation.

In particular, internal friction in the engine will be higher when components are new. Later on, when continued operation of the engine has ensured that the components have 'bedded in', this internal friction will be greatly reduced.

A period of careful breaking-in will ensure lower exhaust emissions, and will optimize performance, fuel economy and longevity of the engine and other motorcycle components.

During the first 500 miles (800 kilometers):

- Do not use full throttle.
- Avoid high engine speeds at all times.
- Avoid riding at one constant engine speed, whether fast or slow, for a long period of time.
- Avoid aggressive starts, stops, and rapid accelerations, except in an emergency.
- Do not ride at speeds greater than 3/4 of maximum engine speed.

From 500 to 1000 miles (800 to 1500 kilometers):

- Engine speed can gradually be increased to the rev limit for short periods.

Both during and after breaking-in has been completed:

- Do not over-rev the engine when cold.
- Do not lug the engine. Always downshift before the engine begins to 'struggle'.
- Do not ride with engine speeds unnecessarily high. Shifting up a gear helps reduce fuel consumption, reduces noise and helps to protect the environment.

## Safe Operation

### Daily Safety Checks



Check the following items each day before you ride. The time required is minimal, and these checks will help ensure a safe, reliable ride.

If any irregularities are found during these checks, refer to the Maintenance and Adjustment section or see your authorized Triumph dealer for the action required to return the motorcycle to a safe operating condition.

### Warning

Failure to perform these checks every day before you ride, or operation of the motorcycle with faults noted in any of the areas below, may result in serious motorcycle damage, loss of motorcycle control and an accident.

Check:

**Fuel:** Adequate supply in tank, no fuel leaks (page 38).

**Engine Oil:** Correct level on sight glass. Add correct specification oil as required (page 66).

**Tires/Wheels:** Correct inflation pressures (when cold). Tread depth/wear (min 0.08 in (2.0 mm), tire/wheel damage and loose/broken spokes, punctures etc. (page 116).

## General Information

---

**Drive Chain:** Check drive chain for correct adjustment and lubrication (page 74).

**Nuts, Bolts, Fasteners:** Visually check that steering and suspension components, axles, and all controls are properly tightened or fastened. Inspect all areas for loose/damaged fasteners.

**Steering Action:** Smooth but not loose from lock to lock. No binding of any of the control cables (page 84).

**Brakes:** Pull the brake lever and push the brake pedal to check for correct resistance. Investigate any lever/pedal where the travel is excessive before meeting resistance, or if either control feels spongy in operation (page 78).

**Brake Pads:** There should be more than 0.06 in (1.5 mm) of friction material remaining on all the pads (page 78).

**Brake Fluid Levels:** No brake fluid leakage. Brake fluid levels must be between the MAX and MIN marks on both reservoirs (page 79).

**Front Forks:** Smooth action. No fork oil leakage (page 85).

**Throttle:** Throttle grip free play 0.08 - 0.12 in (2 - 3 mm). Ensure that the throttle grip returns to the idle position without sticking (page 70).

**Clutch:** Smooth operation and correct cable free play (page 72).

**Electrical Equipment:** All lights and horn function correctly (page 25).

**Engine Stop:** Stop switch turns the engine off (page 32/46).

**Stand:** Returns to the fully up position by spring tension. Return springs not weak or damaged (page 41).

## HOW TO RIDE THE MOTORCYCLE

### Table of Contents

To Stop the Engine .....	46
To Start the Engine .....	46
Moving Off/Shifting Gears .....	48
Braking .....	49
Parking .....	51
Considerations For High-Speed Operation .....	52
General .....	52
Steering .....	52
Luggage .....	52
Brakes .....	53
Tires .....	53
Fuel .....	53
Engine Oil .....	53
Electrical Equipment .....	53
Miscellaneous .....	53

# How to Ride the Motorcycle

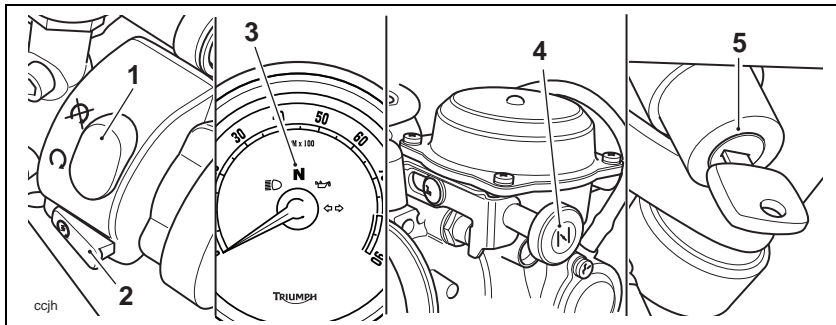

1. Engine stop switch
2. Starter button
3. Neutral indicator light
4. Choke
5. Ignition switch

## To Stop the Engine

- Close the throttle completely.
- Select neutral.
- Turn the ignition switch off.
- Select first gear.
- Support the motorcycle on a firm and level surface with the side stand.
- Withdraw the ignition key from the ignition switch.
- Engage the steering lock (see page 37).

## To Start the Engine

- Release the steering lock.
- Check that the engine stop switch is in the RUN position.
- Insert the ignition key and turn the ignition switch to the ON position.
- Ensure that the transmission is in neutral.
- Pull the clutch lever fully into the handlebar.
- If the engine is cold, pull out the choke, noting the following: Above 77°F (25°C air temperature, pull out the choke to the first position. Below 77°F (25°C air temperature, pull out the choke fully.
- If the engine is partly warm, pull out the choke to the first position.
- Leaving the throttle completely closed, push the starter button until the engine starts.
- Release the clutch lever slowly.
- During warm-up, gradually push the choke in a little at a time as necessary to prevent the engine from racing or stalling.

### **Caution**

The engine should normally be stopped by turning the ignition switch to the OFF position. The engine stop switch is for emergency use only. Do not leave the ignition switched on with the engine stopped. Electrical damage may result.

# How to Ride the Motorcycle

- When the engine is sufficiently warm to idle without the choke, push the choke knob fully in.
- If the engine is hot, ensure that the choke is pushed fully in.

## Warning

Never start the engine or run the engine in a confined area. Exhaust fumes are poisonous and can rapidly cause loss of consciousness and death within a short time.

Always operate your motorcycle in the open-air or in an area with adequate ventilation.

## Caution

This Triumph motorcycle is air cooled and consequently requires air-flow over the cylinders and head to maintain correct engine operating temperature. Extended periods of idling or prolonged rides at very slow speeds, such as in very slow moving or stationary traffic, may overheat the engine resulting in severe damage.

## Caution

Do not operate the starter continuously for more than 5 seconds as the starter motor will overheat and battery power will drop. Wait 15 seconds between each operation of the starter to allow for cooling and recovery of battery power.

## Caution

The low oil pressure warning light should go out as soon as the engine starts.

If the low oil pressure warning light stays on after starting the engine, stop the engine immediately and investigate the cause.

Running the engine with low oil pressure will cause severe engine damage.

### Note:

- **The motorcycle is equipped with starter lockout switches. The switches prevent the electric starter from operating when the transmission is not in neutral with the side stand down.**
- **If the side stand is extended while the engine is running, and the transmission is not in neutral then the engine will stop regardless of clutch position.**

# How to Ride the Motorcycle

## Moving Off/Shifting Gears

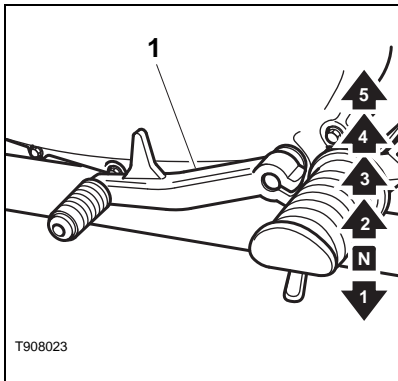

### 1. Gearshift pedal - all models

- Pull in the clutch lever and select first gear. Open the throttle slightly and let out the clutch lever slowly. As the clutch starts to engage, open the throttle a little more, allowing enough engine speed to avoid stalling.
- Close the throttle while pulling in the clutch lever. Shift into the next higher or lower gear. Open the throttle part way, while releasing the clutch lever. Always use the clutch when shifting gear.

### Warning

Take care to avoid opening the throttle too far or too fast in any of the lower gears as this can lead to the front wheel lifting from the ground ('pulling a wheelie') and the rear tire breaking traction (wheel spin).

Always open the throttle cautiously, particularly if you are unfamiliar with the motorcycle as a 'wheelie' or loss of traction will cause loss of motorcycle control and an accident.

### Note:

- **The gearshift mechanism is the 'positive stop' type. This means that, for each movement of the gearshift pedal, you can only select each gear, one after the other, in ascending or descending order.**

### Warning

Do not shift to a lower gear at speeds which will cause excessive engine rpm (r/min). This can lock the rear wheel causing loss of control and an accident. Engine damage may also be caused. Shifting down should only be at moderate engine speeds for each gear.



# How to Ride the Motorcycle

## Braking

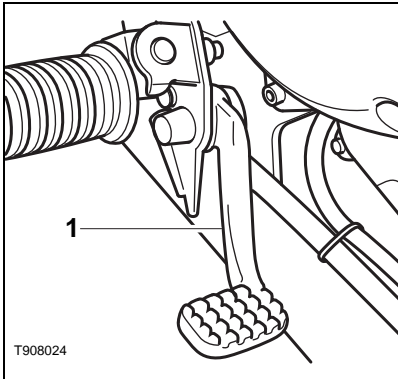

1. Rear brake pedal - all models

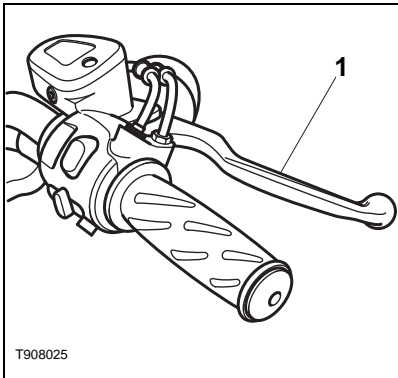

1. Front brake lever - all models

### Warning

#### WHEN BRAKING, OBSERVE THE FOLLOWING:

Close the throttle completely, leaving the clutch engaged to allow the engine to help slow down the motorcycle.

Downshift one gear at a time such that the transmission is in first gear when the motorcycle comes to a complete stop.

When stopping, always apply both brakes at the same time. Normally the front brake should be applied a little more than the rear.

Downshift or fully disengage the clutch as necessary to keep the engine from stalling.

Never lock the brakes, as this may cause loss of control of the motorcycle and an accident.

### Warning

For emergency braking, disregard down-shifting, and concentrate on applying the front and rear brakes as hard as possible without skidding. Riders should practice emergency braking in a traffic-free area.

Incorrect brake technique could result in loss of control and an accident.

Triumph strongly recommend that all riders take a course of instruction which includes advice on safe brake operation.

## How to Ride the Motorcycle

---

### **Warning**

For your safety, always exercise extreme caution when braking, accelerating or turning as any improper action can cause loss of control and an accident. Independent use of the front or rear brakes reduces overall braking performance. Extreme braking may cause either wheel to lock, reducing control of the motorcycle and causing an accident.

When possible, reduce speed or brake before entering a turn as closing the throttle or braking in mid-turn may cause wheel slip leading to loss of control and an accident.

When riding in wet or rainy conditions, or on loose surfaces, the ability to maneuver and stop will be reduced. All of your actions should be smooth under these conditions. Sudden acceleration, braking or turning may cause loss of control and an accident.

### **Warning**

When descending a long, steep gradient, use engine braking by down-shifting and use the brakes intermittently. Continuous brake application can overheat the brakes and reduce their effectiveness.

Riding with your foot on the brake pedal or your hands on the brake lever may actuate the brake light, giving a false indication to other drivers. It may also overheat the brake, reducing braking effectiveness.

Do not coast with the engine switched off, and do not tow the motorcycle. The transmission is pressure-lubricated only when the engine is running. Inadequate lubrication may cause damage or seizure of the transmission which can lead to sudden loss of motorcycle control and an accident.

# How to Ride the Motorcycle

## Parking

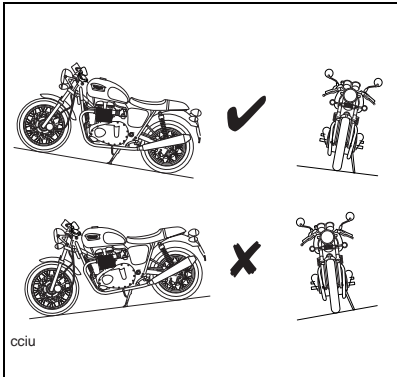

Select neutral and turn the ignition switch to the OFF position.

Lock the steering to help prevent theft.

Always park on a firm, level surface to prevent the motorcycle from falling.

When parking on a hill, always park facing uphill to prevent the motorcycle from rolling off the stand.

On a lateral (sideways) incline, always park such that the incline naturally pushes the motorcycle towards the side stand.

Do not park on a lateral (sideways) incline of greater than 6° and never park facing downhill.

### Note:

- **When parking near traffic at night, or when parking in a location where parking lights are required by law, leave the tail, license plate and position lights on by turning the ignition switch to P (PARK).**

Do not leave the switch in the P position for long periods as this will discharge the battery. Ensure that the stand is fully retracted before riding off.

### Warning

Do not park on a soft or on a steeply inclined surface. Parking under these conditions may cause the motorcycle to fall over causing damage to property and personal injury.

### Warning

Gasoline is extremely flammable and can be explosive under certain conditions. If parking inside a garage or other structure, be sure it is well ventilated and the motorcycle is not close to any source of flame or sparks. This includes any appliance with a pilot light.

Failure to follow the above advice may cause a fire resulting in damage to property or personal injury.

### Warning

The engine and exhaust system will be hot after riding. **DO NOT** park where pedestrians and children are likely to touch the motorcycle.

Touching any part of the engine or exhaust system when hot may cause unprotected skin to become burnt.

# How to Ride the Motorcycle

---

## Considerations For High-Speed Operation

### Warning

This Triumph motorcycle should be operated within the legal speed limits for the particular road travelled. Operating a motorcycle at high speeds can be potentially dangerous since the time available to react to given traffic situations is greatly reduced as road speed increases. Always reduce speed in consideration of weather and traffic conditions.

### Warning

Only operate this Triumph motorcycle at high speed in closed-course on-road competition or on closed-course racetracks. High-speed operation should only then be attempted by riders who have been instructed in the techniques necessary for high-speed riding and are familiar with the motorcycle's characteristics in all conditions.

High-speed operation in any other circumstances is dangerous and will lead to loss of motorcycle control and an accident.

### Warning

The handling characteristics of a motorcycle at high speed may vary from those you are familiar with at legal road speeds. Do not attempt high-speed operation unless you have received sufficient training and have the required skills as a serious accident may result from incorrect operation.

### Warning

The items listed are extremely important and must never be neglected. A problem which may not be noticed at normal operating speeds may be greatly exaggerated at high speeds.

### General

Ensure the motorcycle has been maintained according to the scheduled maintenance chart.

### Steering

Check that the handlebar turns smoothly without excessive free play or tight spots. Ensure that the control cables do not restrict the steering in any way.

### Luggage

Make certain that any luggage containers are closed, locked and securely fitted to the motorcycle.

# How to Ride the Motorcycle

---

## Brakes

Check that the front and rear brakes are functioning properly.

## Tires

High-speed operation is hard on tires, and good tires are crucial for riding safely. Examine their overall condition, inflate to the correct pressure (when the tires are cold), and check the wheel balance. Securely install the valve caps after checking tire pressures. Observe the information given in the Maintenance and Specification sections on tire checking and tire safety.

## Fuel

Have sufficient fuel for the higher consumption experienced during high-speed operation.

## Engine Oil

Make certain that the oil level is correct. Ensure that the correct grade and type of oil is used when topping-off.

## Electrical Equipment

Make certain that the headlight, brake/tail light, turn signals, horn etc., all work properly.

## Miscellaneous

Make certain that all fasteners are tight and that all safety related parts are in good condition.



### Caution

The exhaust system is fitted with a catalytic converter to help reduce exhaust emission levels. The catalytic converter can be permanently damaged if the motorcycle is allowed to run out of fuel or if the fuel level is allowed to get very low. Always ensure you have adequate fuel for your journey.

# How to Ride the Motorcycle

---

This page intentionally left blank

### ACCESSORIES AND LOADING

The addition of accessories and carrying additional weight can affect the motorcycle's handling characteristics causing changes in stability and necessitating a reduction in speed. The following information has been prepared as a guide to the potential hazards of adding accessories to a motorcycle and carrying passengers and additional loads.

#### **Warning**

Incorrect loading may result in an unsafe riding condition leading to an accident.

Always ensure any loads carried are evenly distributed on both sides of the motorcycle. Ensure that the load is correctly secured such that it will not move around while the motorcycle is in motion.

Always check the load security regularly (though not while the motorcycle is in motion) and ensure that the load does not extend beyond the rear of the motorcycle.

Never exceed the maximum vehicle loading weight of 440 lbs (200 kg).

This maximum loading weight is made up from the combined weight of the rider, passenger and any load carried.

#### **Warning**

Do not install accessories or carry luggage that impairs the control of the motorcycle. Make sure that you have not adversely affected the visibility or operation of any lighting component, changed road clearance or banking capability (i.e. lean angle), control operation, wheel travel, front fork movement, or any other aspect of the motorcycle's operation.

#### **Warning**

Never ride an accessory equipped motorcycle, or a motorcycle carrying a payload of any kind, at speeds above 80 mph (130 km/h). In either/both of these conditions, speeds in excess of 80 mph (130 km/h) should not be attempted even where the legal speed limit permits this.

The presence of accessories and/or payload will cause changes in the stability and handling of the motorcycle.

Failure to allow for changes in motorcycle stability may lead to loss of control or an accident.

Remember that the 80 mph (130 km/h) absolute limit will be reduced by the fitting of non-approved accessories, incorrect loading, worn tires, overall motorcycle condition and poor road or weather conditions.

## Accessories and Loading

---

### Warning

This motorcycle must not be operated above the legal road speed limit except in authorized closed-course conditions.

### Warning

Only operate this Triumph motorcycle at high speed in closed-course on-road competition or on closed-course racetracks. High-speed operation should only then be attempted by riders who have been instructed in the techniques necessary for high-speed riding and are familiar with the motorcycle's characteristics in all conditions.

High-speed operation in any other circumstances is dangerous and will lead to loss of motorcycle control and an accident.

### Warning

The handling and braking capabilities of a motorcycle will be affected by the presence of a passenger. The rider must make allowances for these changes when operating the motorcycle with a passenger and should not attempt such operation unless trained to do so and without becoming familiar and comfortable with the changes in motorcycle operating characteristics that this brings about.

Motorcycle operation without making allowances for the presence of a passenger could lead to loss of motorcycle control and an accident.

### Warning

Your passenger should be instructed that he or she can cause loss of motorcycle control by making sudden movements or by adopting an incorrect seated position.

The rider should instruct the passenger as follows:

- It is important that the passenger sits still while the motorcycle is in motion and does not interfere with the operation of the motorcycle.
- To keep his or her feet on the passenger footrests and to firmly hold onto the seat strap or the rider's waist or hips.
- Advise the passenger to lean with the rider when travelling around corners and not to lean unless the rider does so.

### Warning

Do not carry animals on your motorcycle.

An animal could make sudden and unpredictable movements that could lead to loss of motorcycle control and an accident.



## Accessories and Loading

---

### **Warning**

Do not carry a passenger unless he or she is tall enough to reach the footrests provided.

A passenger who is not tall enough to reach the footrests will be unable to sit securely on the motorcycle and may cause instability leading to loss of control and an accident.

### **Warning**

Never attempt to store any items between the frame and the steering equipment. This can restrict the steering and will cause loss of control leading to an accident.

Weight attached to the handlebar or front fork will increase the mass of the steering assembly and can result in loss of steering control leading to an accident.

### **Warning**

If the passenger seat is used to carry small objects, they must not exceed 11 lbs (5 kg) in weight, must not impair control of the motorcycle, must be securely attached and must not extend beyond the rear or sides of the motorcycle.

Carrying of objects in excess of 11 lbs (5 kg) in weight, that are insecure, impair control or extend beyond the rear or sides of the motorcycle may lead to loss of motorcycle control and an accident.

Even if small objects are correctly loaded onto the rear seat, the maximum speed limit must be reduced to 80 mph (130 km/h).

## Accessories and Loading

---

This page intentionally left blank

## MAINTENANCE AND ADJUSTMENT

### Table of Contents

Scheduled Maintenance . . . . .	62
Recording Scheduled Maintenance . . . . .	65
Engine Oil . . . . .	66
Oil Level Inspection . . . . .	66
Oil and Oil Filter Change . . . . .	67
Disposal of Used Engine Oil . . . . .	69
Oil Specification and Grade . . . . .	69
Throttle Grip . . . . .	70
Inspection . . . . .	70
Adjustment . . . . .	71
Clutch . . . . .	72
Inspection . . . . .	73
Adjustment . . . . .	73
Drive Chain . . . . .	74
Chain Lubrication . . . . .	75
Chain Free-Movement . . . . .	75
Chain Wear Inspection . . . . .	77
Brakes . . . . .	78
Brake Pad Wear Inspection . . . . .	78
Brake Pad Wear Compensation . . . . .	79
Brake Light Switches . . . . .	79
Brake Fluid . . . . .	79
Front Brake Fluid Level Inspection and Adjustment - Bonneville T100 and Thruxton . . . . .	81
Front Brake Fluid Level Inspection and Adjustment - Bonneville, Bonneville SE and Scrambler . . . . .	81
Rear Brake Fluid Level Inspection and Adjustment - Bonneville, Bonneville SE, Bonneville T100 and Thruxton . . . . .	82
Rear Brake Fluid Level Inspection and Adjustment - Scrambler . . . . .	83
Steering/Wheel Bearings . . . . .	84
Steering Inspection . . . . .	84
Inspection . . . . .	84
Wheel Bearings Inspection . . . . .	85

# Maintenance and Adjustment

---

Front Suspension . . . . .	85
Front Fork Inspection . . . . .	85
Suspension Setting . . . . .	86
Front Suspension Adjustment . . . . .	86
Rear Suspension Adjustment . . . . .	87
Suggested Suspension Settings . . . . .	87
Tires . . . . .	88
Tire Inflation Pressures . . . . .	90
Tire Wear . . . . .	90
Minimum Recommended Tread Depth . . . . .	90
Tire Replacement . . . . .	91
Battery . . . . .	93
Battery Disposal . . . . .	94
Battery Removal . . . . .	94
Battery Maintenance . . . . .	95
Battery Discharge . . . . .	95
Battery Discharge During Storage and Infrequent Use of the Motorcycle . . . . .	95
Battery Charging . . . . .	96
Battery Installation . . . . .	97
Fuses . . . . .	97
Fuse Location . . . . .	97
Fuse Replacement . . . . .	97
Fuse Identification . . . . .	98
Headlight . . . . .	99
Headlight Adjustment . . . . .	99
Headlight/Position Light Bulb Replacement . . . . .	100
Brake/Tail Light/License Plate Light . . . . .	101
Brake/Tail Light . . . . .	101
Bulb Replacement . . . . .	101
Turn Signal Lights . . . . .	101
Bulb Replacement . . . . .	101
Cleaning . . . . .	102
Preparation for Washing . . . . .	102
Where to be Careful . . . . .	102
After Washing . . . . .	103

## Maintenance and Adjustment

---

Unpainted Aluminum Items .....	103
Cleaning of Exhaust System .....	104
Accessory Windshield Cleaning .....	104

# Maintenance and Adjustment

---

## Scheduled Maintenance

To maintain the motorcycle in a safe and reliable condition, the maintenance and adjustments outlined in this section must be carried out as specified in the schedule of daily checks, and also in line with the scheduled maintenance chart. The information that follows describes the procedures to follow when carrying out the daily checks and some simple maintenance and adjustment items.

**Warning**

Special tools, knowledge and training are required in order to correctly carry out the maintenance items listed in the scheduled maintenance chart. Only an authorized Triumph dealer will have this knowledge and equipment.

Since incorrect or neglected maintenance can lead to a dangerous riding condition, always have an authorized Triumph dealer carry out the scheduled maintenance of this motorcycle.

# Maintenance and Adjustment

Operation Description	Odometer Reading in Miles (Kms) or Time Period, whichever comes first					
		First Service	A Service	B Service	C Service	D service
	Every	500 (800) 1 month	6,000 (10,000) 1 year	12,000 (20,000) 2 years	18,000 (30,000) 3 years	24,000 (40,000) 4 years
Engine and oil cooler - check for leaks	Day	•	•	•	•	•
Engine oil - replace	-	•	•	•	•	•
Engine oil filter - replace	-	•	•	•	•	•
Valve clearances - check/adjust	-			•		•
Air cleaner - replace	-			•		•
Spark plugs - check	-		•		•	
Spark plugs - replace	-			•		•
Engine ECM - check for stored DTCs	-	•	•	•	•	•
Fuel filter - replace	-			•		•
Fuel system - check for leaks, chafing etc.	Day	•	•	•	•	•
Throttle cables - check/adjust	Day	•	•	•	•	•
Lights, instruments and electrical systems - check	Day	•	•	•	•	•
Steering - check for free operation	Day	•	•	•	•	•
Steering head bearings - check/adjust	-	•	•	•	•	•
Steering head bearings - lubricate	-			•		•
Forks - check for leaks/smooth operation	Day	•	•	•	•	•
Fork oil - replace	-					•
Brake fluid levels - check	Day	•	•	•	•	•
Brake calipers, check for fluid leaks and seized pistons	-	•	•	•	•	•

# Maintenance and Adjustment

Operation Description	Odometer Reading in Miles (Kms) or Time Period, whichever comes first					
		First Service	A Service	B Service	C Service	D service
	Every	500 (800) 1 month	6,000 (10,000) 1 year	12,000 (20,000) 2 years	18,000 (30,000) 3 years	24,000 (40,000) 4 years
Brake master cylinders - check for fluid leaks	-	•	•	•	•	•
Brake fluid - replace	Every 2 years					
Brake light - check operation	Day	•	•	•	•	•
Brake pads - check wear levels	Day	•	•	•	•	•
Drive chain - lubricate	Every 200 miles (300 kms)					
Drive chain - wear check	Every 500 miles (800 kms)					
Drive chain slack - check/adjust	Day	•	•	•	•	•
Wheels - inspect for damage	Day	•	•	•	•	•
Wheels - check wheels for broken or damaged spokes and check spoke tightness	Day	•	•	•	•	•
Wheel bearings - check for wear/smooth operation	-	•	•	•	•	•
Tire wear/tire damage - check	Day	•	•	•	•	•
Tire pressures - check/adjust	Day	•	•	•	•	•
Clutch cable - check/adjust	Day	•	•	•	•	•
Fasteners - inspect visually for security	Day	•	•	•	•	•
Fuel and evaporative* hoses - replace	-					•
Secondary air injection system - check/clean	-			•		•

\* Evaporative hoses on California models only



# Maintenance and Adjustment

## **Warning**

All maintenance is vitally important and must not be neglected. Incorrect maintenance or adjustment may cause one or more parts of the motorcycle to malfunction. A malfunctioning motorcycle is dangerous and may lead to an accident.

Weather, terrain and geographical location affects maintenance. The maintenance schedule should be adjusted to match the particular environment in which the vehicle is used and the demands of the individual owner.

Since incorrect or neglected maintenance can lead to a dangerous riding condition, always have an authorized Triumph dealer carry out the scheduled maintenance of this motorcycle.

Triumph Motorcycles cannot accept any responsibility for damage or injury resulting from incorrect maintenance or improper adjustment carried out by the owner.

## Recording Scheduled Maintenance

### Scheduled Service

**6000 Miles  
10,000 Kms or  
1 Year whichever comes first.**

Dealer Stamp

Service carried out in accordance with the scheduled maintenance chart.

Date .....

Miles/Kms .....

### Service Handbook Entry

Each time you visit your authorized Triumph dealer for scheduled servicing, always present your service handbook to the dealer's reception staff.

The service handbook is your record that the scheduled maintenance procedures have been carried out as required under the terms of the motorcycle warranty.

On collecting the motorcycle after servicing, always ensure that your service handbook has been stamped and the date of servicing and current odometer reading recorded.

This information will be needed in the event of a warranty claim and will also enhance the value of your motorcycle for future owners.

# Maintenance and Adjustment

## Engine Oil

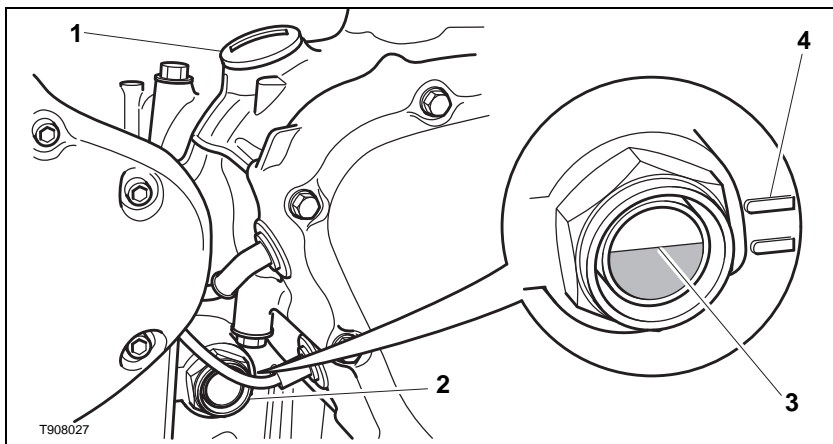

1. Filler
2. Sight glass
3. Oil level (correct level shown)
4. Crankcase oil level lines

In order for the engine, transmission, and clutch to function correctly, maintain the engine oil at the correct level, and change the oil and oil filter in accordance with scheduled maintenance requirements.

### **Warning**

Motorcycle operation with insufficient, deteriorated, or contaminated engine oil will cause accelerated engine wear and may result in engine or transmission seizure. Seizure of the engine or transmission may lead to loss of control and an accident.

### Oil Level Inspection

- Start the engine and run at idle for approximately five minutes.
- Stop the engine, then wait for at least three minutes to allow the oil to settle.
- Note the oil level visible in the sight glass.
- When correct, oil should be visible in the sight-glass at a point mid-way between the two horizontal lines marked on the crankcase.

### Note:

- **The actual level is indicated when the motorcycle is level and upright, not on the side stand.**

# Maintenance and Adjustment

- If it is necessary to top-off the oil level, remove the filler plug and add oil, a little at a time, until the level registered in the sight glass is correct. On Scrambler models, a suitable funnel may be required to add oil to the oil filler hole.

## Warning

If the engine has recently been running, the exhaust system will be hot. Before working on or near the exhaust system, allow sufficient time for the exhaust system to cool as touching any part of a hot exhaust system could cause burn injuries.

- Once the correct level is reached, install and fully tighten the filler plug.

## Oil and Oil Filter Change

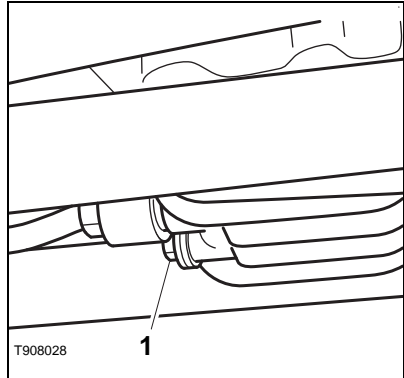

### 1. Oil drain plug

## Warning

Prolonged or repeated contact with engine oil can lead to skin dryness, irritation and dermatitis. In addition, used engine oil contains potentially harmful contaminants which can cause cancer. Wear suitable clothing and avoid skin contact.

The engine oil and filter must be replaced in accordance with scheduled maintenance requirements.

- Warm up the engine thoroughly, and then stop the engine.
- Place an oil pan beneath the engine.
- Remove the engine drain plug.

# Maintenance and Adjustment

## Warning

The oil may be hot to the touch. Avoid contact with the hot oil by wearing suitable protective clothing, gloves, eye protection etc. Contact with hot oil may cause the skin to be scalded or burned.

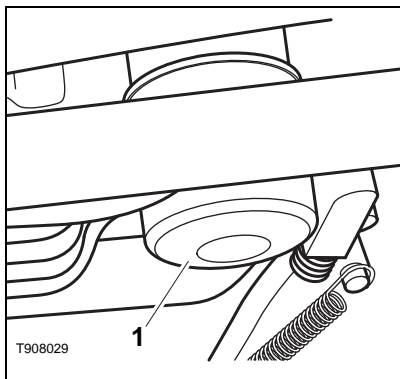

### 1. Oil filter

- Unscrew and remove the oil filter using the Triumph service tool T3880313.
- Discard the oil filter.
- Pre-fill the replacement oil filter with new engine oil.
- Apply a smear of **clean engine oil to the sealing ring** of the new oil filter. Install the oil filter and tighten to **7 lbf ft (10 Nm)**.
- After the oil has completely drained out, install a new sealing washer to the drain plug. Install and tighten the plug to **18 lbf ft (25 Nm)**.

## Warning

If the engine has recently been running, the exhaust system will be hot. Before working on or near the exhaust system, allow sufficient time for the exhaust system to cool as touching any part of a hot exhaust system could cause burn injuries.

- Remove the oil filler plug. Fill the engine with new oil of the type and grade listed in the Specification section, until oil begins to show in the sight glass. On Scrambler models, a suitable funnel may be required to add oil to the oil filler hole.
- Do not overfill or exceed the capacities given in the Specification section.
- Start the engine and allow it to idle for a minimum of 30 seconds.

## Caution

Raising the engine speed above idle, before the oil reaches all parts of the engine can cause engine damage or seizure. Only raise engine speed after running the engine for 30 seconds to allow the oil to circulate fully.

- Ensure that the oil pressure warning light extinguishes shortly after starting.



## Caution

If the engine oil pressure is too low, the low oil pressure warning light will illuminate. If this warning light stays on when the engine is running, stop the engine immediately and investigate the cause. Running the engine with low oil pressure will cause engine damage.

- Stop the engine and re-check the oil level. Adjust if necessary.

## Disposal of Used Engine Oil

To protect the environment, do not pour oil on the ground, down sewers or drains, or into groundwater sources. Dispose of used oil sensibly. If in doubt, contact your local authority.

## Oil Specification and Grade



## Caution

Triumph high performance engines are designed to use semi or fully synthetic 10W/40 or 15W/50 motorcycle engine oil which meets specification API SH or higher (i.e. SJ, SK or SL) AND JASO MA.

Do not add any chemical additives to the engine oil. The engine oil also lubricates the clutch and any additives could cause the clutch to slip.

Do not use mineral, vegetable, non-detergent oil, castor based oils or any oil not conforming to the required specification. The use of these oils may cause instant, severe engine damage.

Ensure no foreign matter enters the crankcase during an oil change or top-off.

# Maintenance and Adjustment

## Throttle Grip

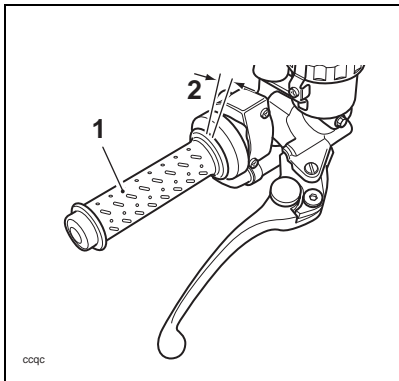

1. Throttle grip
2. 0.08 - 0.12 in (2 - 3 mm)

## Inspection

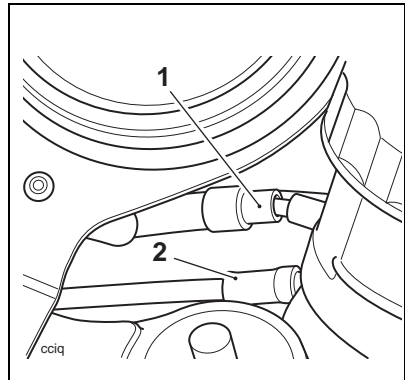

1. 'Opening' cable adjuster - twist grip end
2. 'Closing' cable

### Warning

The throttle grip controls the throttle valves in the throttle bodies. If the throttle cables are incorrectly adjusted, either too tight or too loose, the throttle may be difficult to control and performance will be adversely affected.

Check the throttle grip free play in accordance with scheduled maintenance requirements and make adjustments as necessary.

Always be alert for changes in the 'feel' of the throttle and have the throttle system checked by an authorized Triumph dealer if any changes are detected. Changes can be due to wear in the mechanism, which could lead to a sticking throttle.

An incorrectly adjusted, sticking or stuck throttle will lead to loss of motorcycle control and an accident.

- Check that the throttle opens smoothly, without undue force and that it closes without sticking. Have your authorized Triumph dealer check the throttle system if a problem is detected or any doubt exists.
- Check that there is 0.08 - 0.12 in (2 - 3 mm) throttle grip free play when lightly turning the throttle grip back and forth.
- If there is an incorrect amount of free play, Triumph recommends that you have adjustments made by an authorized Triumph dealer. However, in an emergency, throttle adjustments may be made as follows:

# Maintenance and Adjustment

## Adjustment

### Warning

Use of the motorcycle with incorrectly adjusted, incorrectly routed, sticking or damaged throttle cables could interfere with the throttle function resulting in loss of control of the motorcycle and an accident.

To avoid incorrect adjustment, incorrect routing, or continued use of a sticking or damaged throttle, always have the throttle checked and adjusted by your authorized Triumph dealer.

### Note:

- **Minor adjustments can be made using the adjusters near the twist grip end of the throttle. Where a correct setting cannot be achieved in this way, the adjusters at the throttle body end must be used. The 'opening' cable must be set first followed by the 'closing' cable.**
  - Remove the seat.
  - Disconnect the battery, negative (black) lead first.
  - Set the 'opening' cable adjuster at the twist grip end such that it has an equal amount of adjustment in each direction.

- Set the 'opening' cable adjuster at the throttle body end of the cable to give 0.08 - 0.12 in (2 - 3 mm) of play at the twist grip. Tighten the locknut.

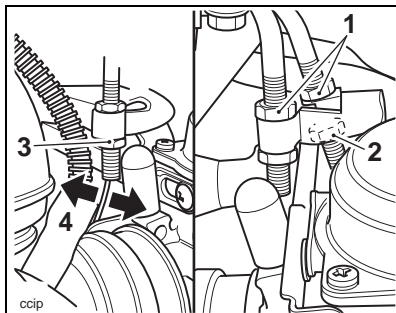

#### 1. Locknuts

#### 2. Opening cable adjuster

#### 3. Closing cable adjuster

#### 4. Closing cable - free play measurement point

- Make any minor adjustments as necessary to give 0.08 - 0.12 in (2 - 3 mm) of play using the adjuster near the twist grip end of the cable. Tighten the locknut.
- With the throttle fully closed, ensure that there is 0.08 - 0.12 in (2 - 3 mm) of free play in the 'closing' cable. Adjust as for the 'opening' cable if necessary. Tighten the locknut.

# Maintenance and Adjustment

## Warning

Ensure that both the adjuster locknuts of both cables are tightened as a loose locknut could result in a sticking throttle. An incorrectly adjusted, sticking or stuck throttle can lead to loss of motorcycle control and an accident.

- Reconnect the battery, positive (red) lead first.
- Install the seat.
- Check that the throttle opens smoothly, without undue force and that it closes without sticking.
- Ride carefully to your nearest authorized Triumph dealer and have them check the throttle system thoroughly before riding again.

## Clutch

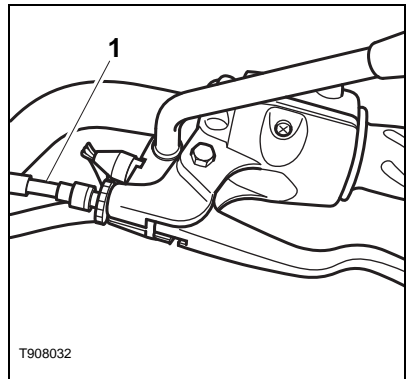

### 1. Clutch cable

The motorcycle is equipped with a cable-operated clutch.

If the clutch lever has excessive free play, the clutch may not disengage fully and could then cause the engine to stall and create difficulties when shifting gear. Conversely, if the clutch lever has insufficient free play the clutch may not engage fully, causing clutch slip.

Clutch lever free play must be checked in accordance with scheduled maintenance requirements.



# Maintenance and Adjustment

## Inspection

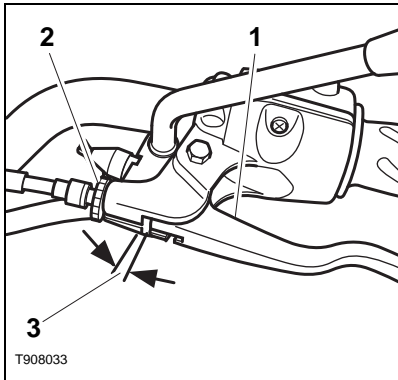

### 1. Lever

### 2. Adjuster (lever end)

### 3. 0.08 - 0.12 in (2 - 3 mm)

- Check that there is 0.08 - 0.12 in (2 - 3 mm) of clutch lever free play at the point shown in the diagram above.
- If there is an incorrect amount of free play, adjustments must be made.

## Adjustment

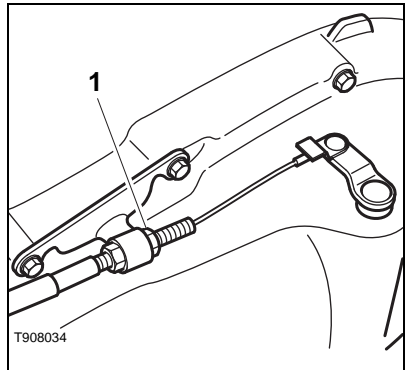

### 1. Adjuster (engine end)

### Note:

- **Knurled locknuts are fitted to Thruxton and Bonneville T100 models only. Bonneville, Bonneville SE and Scrambler models have a ratchet type adjuster.**
- Loosen the knurled locknut at the lever end of the clutch cable and turn the adjuster sleeve until the correct amount of clutch lever free play is achieved.
- Tighten the knurled locknut at the clutch lever assembly.
- If the correct adjustment setting cannot be achieved using the lever adjuster, use the adjuster at the engine end of the cable.
- Loosen the adjuster locknut.

## Maintenance and Adjustment

---

- Turn the outer cable adjuster to give 0.08 - 0.12 in (2 - 3 mm) of free play at the clutch lever.
- Tighten the locknut.
- Use the lever adjuster to make minor adjustments as necessary.
- Ensure all locknuts are secured at both ends of the cable.

### Drive Chain



For safety and to prevent excessive wear, the drive chain must be checked, adjusted, and lubricated in accordance with scheduled maintenance requirements. Checking, adjustment and lubrication must be carried out more frequently for extreme conditions such as dusty, wet, salty or heavily gritted roads.

If the chain is badly worn or incorrectly adjusted (either too loose or too tight) the chain could jump off the sprockets or break.

#### **Warning**

A loose or worn chain, or a chain that breaks or jumps off the sprockets could catch on the engine sprocket or lock the rear wheel.

A chain that catches on the engine sprocket will injure the rider and lead to loss of motorcycle control and an accident. Similarly, locking the rear wheel will lead to loss of motorcycle control and an accident.

# Maintenance and Adjustment

## Chain Lubrication



Lubrication is necessary every 200 miles (300 kms) and also after riding in wet weather, on wet roads, or any time that the chain appears dry.

Use the special chain lubricant as recommended in the Specification section.

- Apply lubricant to the sides of the rollers. This will allow the oil to penetrate to the chain rollers and bushes. Also apply oil to the chain 'X' rings. Wipe off any excess oil.
- If the chain is especially dirty, clean first using paraffin and then apply lubricant as mentioned above.

### **Caution**

Do not use a power 'jet' wash to clean the chain as this may cause damage to the chain components.

## Chain Free-Movement

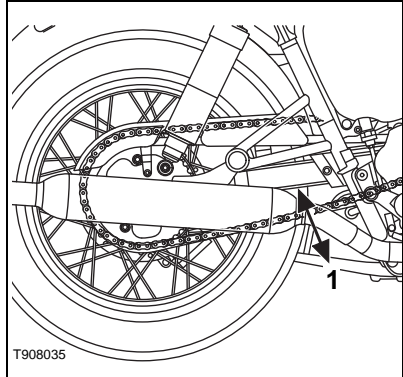

### 1. Maximum movement position

#### Inspection

- Support the motorcycle on a firm, level surface with the side stand.
- Rotate the rear wheel to find the position where the chain is tightest, and measure the vertical movement of the chain midway between the sprockets.
- For Thruxton and Scrambler the vertical movement of the drive chain must be 1.18 - 1.57 in (30 - 40 mm).
- For Bonneville the vertical movement of the drive chain must be 0.59 - 1.18 in (15 - 30 mm).

# Maintenance and Adjustment

## Adjustment

- If the chain free-movement measurement is incorrect, adjustments must be made as follows:
- Loosen the wheel spindle nut.
- Moving both adjusters by an equal amount, turn the adjuster bolts clockwise to increase chain free-movement and counter-clockwise to reduce chain free-movement.

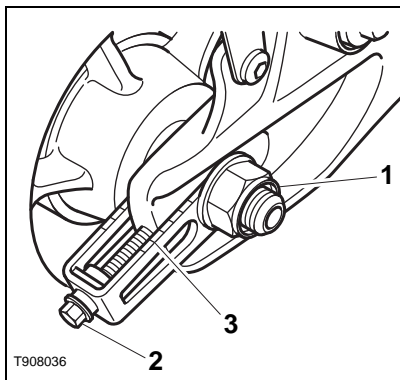

1. Rear wheel spindle nut
2. Adjusters
3. Wheel alignment markings

- When the correct amount of chain free-movement has been set, tighten the rear wheel spindle nut to **63 lbf ft (85 Nm)**.
- Tighten the adjusters, counter-clockwise, to **18 lbf in (2 Nm)**.
- Ensure that the wheel alignment markings fall in the same position on

both sides of the motorcycle. Adjust as necessary if incorrect.

- Rotate the rear wheel and repeat the chain adjustment check. Re-adjust if necessary.

## Warning

Operation of the motorcycle with a loose wheel spindle may result in impaired stability and handling of the motorcycle. This impaired stability and handling may lead to loss of control or an accident.

- Check the rear brake effectiveness.

# Maintenance and Adjustment

## Chain Wear Inspection

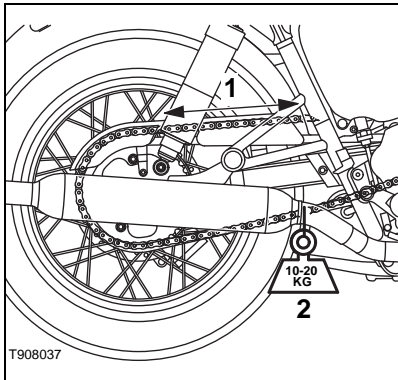

### 1. Measure across 20 links

### 2. Weight

- Remove the chain guard.
- Stretch the chain taut by hanging a 20 - 40 lb (10 - 20 kg) weight on the chain.
- Measure the length of 20 links on the straight part of the chain from pin center of the 1<sup>st</sup> pin to the center of the 21<sup>st</sup> pin. Since the chain may wear unevenly, take measurements at several places.
- If the length exceeds the maximum service limit of 12.63 in (321 mm), the chain must be replaced.
- Rotate the rear wheel and inspect the drive chain for damaged rollers, and loose pins and links.

- Also remove the sprocket cover and inspect the sprockets for unevenly or excessively worn or damaged teeth.

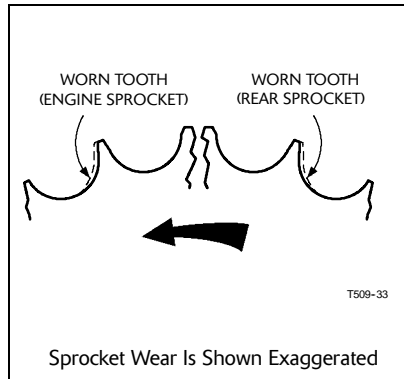

Sprocket Wear Is Shown Exaggerated

- If there is any irregularity, have the drive chain and sprockets replaced by an authorized Triumph dealer.
- Install the chain guard and sprocket cover.

## **Warning**

The use of non-approved chains may result in a broken chain or may cause the chain to jump off the sprockets. Either condition could lock the rear wheel, severely damaging the motorcycle and causing loss of control and an accident.

For safety, use a genuine Triumph supplied chain as specified in the Triumph parts catalog.

Never neglect chain maintenance and always have chains installed by an authorized Triumph dealer.

# Maintenance and Adjustment

## **Caution**

If the sprockets are found to be worn, always replace the sprockets and drive chain together.

Replacing worn sprockets without also replacing the chain will lead to premature wear of the new sprockets.

## Brakes

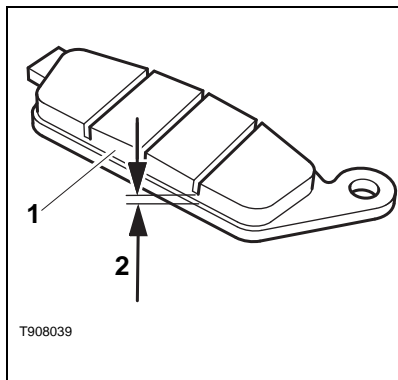

1. Lining material thickness
2. 0.06 in (1.5 mm) groove thickness

### Brake Pad Wear Inspection

Brake pads must be inspected in accordance with the scheduled maintenance requirements and replaced if worn to, or beyond, the minimum service thickness.

If the lining thickness of any pad (front or rear brakes) is less than 0.06 in (1.5 mm), that is, if the pad has worn down to the bottom of the grooves, replace all the pads on the wheel.

## Warning

Brake pads must always be replaced as a wheel set. At the front, where two calipers may be fitted on the same wheel, replace all the brake pads in both calipers.

Replacing individual pads will reduce braking efficiency and may cause loss of motorcycle control and an accident.

After replacement pads have been fitted, ride with extreme caution until the new pads have 'broken in'.

### Brake Pad Wear Compensation

Disc and disc pad wear is automatically compensated for and has no effect on the brake lever or pedal action. There are no parts that require adjustment on the front and rear brakes.

## Warning

If the brake lever or pedal feels soft when it is applied, or if the lever/pedal travel becomes excessive, there may be air in the brake lines or the brake may be defective.

It is dangerous to operate the motorcycle under such conditions and remedial action must be taken by your authorized Triumph dealer before riding.

Riding with defective brakes may lead to loss of motorcycle control and an accident.

### Brake Light Switches

The brake light is activated independently by either the front or rear brake. If the brake light does not work when the front brake lever is pulled, or the rear brake pedal is pressed, ask your authorized Triumph dealer to investigate and rectify the fault.

## Warning

Riding the motorcycle with defective brake lights is illegal and dangerous.

An accident causing injury to the rider and other road users may result from use of a motorcycle with defective brake lights.

### Brake Fluid

Inspect the level of brake fluid in both reservoirs and change the brake fluid in accordance with scheduled maintenance requirements. At the front, use only DOT 4 fluid.

At the rear, DOT 3 or DOT 4 specification fluid may be used on the Bonneville, Bonneville SE, Bonneville T100 and Thruxton models only. Scrambler models must use DOT 4 specification fluid. The brake fluid must be changed if it becomes, or is suspected of having become contaminated with moisture or any other contaminants.

## Maintenance and Adjustment

---

### **Warning**

If the brake fluid in either reservoir has become, or is suspected of having become contaminated, consult your authorized Triumph dealer for advice, before riding. Contaminated brake fluid may cause the brakes to become defective. Riding with defective brakes may lead to loss of motorcycle control and an accident.

### **Warning**

If there has been an appreciable drop in the level of fluid in either fluid reservoir, consult your authorized Triumph dealer before riding. Riding with depleted brake fluid levels or with a brake fluid leak is dangerous and will cause reduced brake performance potentially leading to loss of motorcycle control and an accident.

### **Warning**

Brake fluid is hygroscopic which means it will absorb moisture from the air.

Any absorbed moisture will greatly reduce the boiling point of the brake fluid causing a reduction in braking efficiency.

Because of this, always replace brake fluid in accordance with the scheduled maintenance requirements.

Always use new brake fluid from a sealed container and never use fluid from an unsealed container or from one which has been previously opened.

Do not mix different brands or grades of brake fluid.

Check for fluid leakage around brake fittings, seals and joints and also check the brake hoses for splits, deterioration and damage.

Always rectify any faults before riding.

Failure to observe and act upon any of these items may cause a dangerous riding condition leading to loss of motorcycle control and an accident.



# Maintenance and Adjustment

## Front Brake Fluid Level Inspection and Adjustment - Bonneville T100 and Thruxton

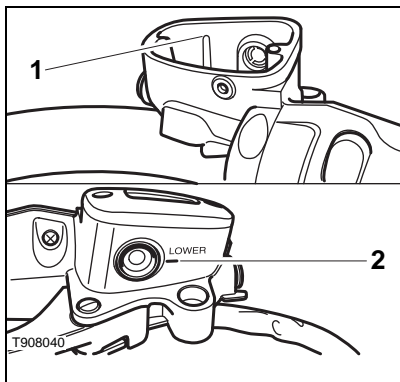

1. Upper level line, front brake
2. Lower level line, front brake

- To inspect the front fluid level, check the level of fluid visible in the window at the front of the reservoir body.
- The brake fluid level must be kept between the upper and lower level lines (reservoir held horizontal).
- To adjust the fluid level, remove the cap screws and detach the cover noting the position of the sealing diaphragm.
- Fill the reservoir to the upper level line using new DOT 4 fluid from a sealed container.
- Install the cover, ensuring that the diaphragm seal is correctly positioned between the cap and reservoir body.
- Tighten the cap retaining screws.

## Front Brake Fluid Level Inspection and Adjustment - Bonneville, Bonneville SE and Scrambler

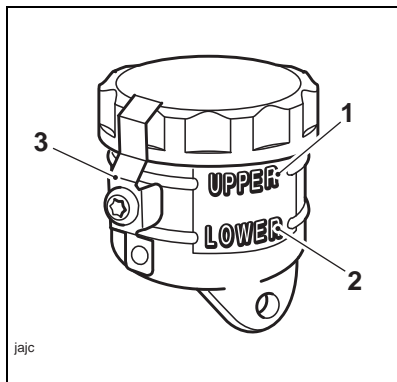

1. Upper level line, front brake
2. Lower level line, front brake
3. Safety clip

- The brake fluid level in the reservoirs must be kept between the upper and lower level lines (reservoir held horizontal).
- Remove the safety clip.
- Remove the reservoir cap.
- Fill the reservoir to the upper level line using new DOT 4 fluid from a sealed container.
- Install the reservoir cap ensuring that the diaphragm seal is correctly installed.
- Install the safety clip.

# Maintenance and Adjustment

## Rear Brake Fluid Level Inspection and Adjustment - Bonneville, Bonneville SE, Bonneville T100 and Thruxton

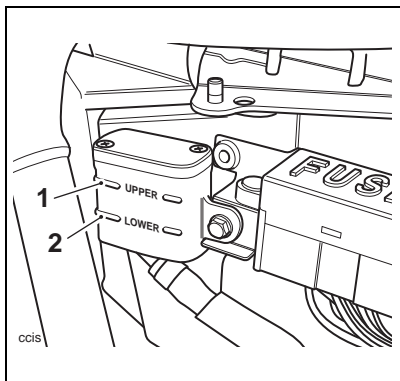

### 1. Upper level, rear brake

### 2. Lower level, rear brake

- Fill the reservoir to the upper level line using new DOT 3 or DOT 4 fluid from a sealed container.
  - Install the reservoir cap ensuring that the diaphragm seal is correctly positioned between the cap and reservoir body. Tighten the cap retaining screws.
  - Retain the reservoir to the airbox by tightening the original fastener.
  - Install the right hand side cover.
- To inspect the rear brake fluid level, remove the right hand side cover as described in the General Information section.
  - The brake fluid level in the rear reservoir must be kept between the upper and lower level lines.
  - To adjust the fluid level, detach the reservoir from the airbox without detaching the connecting hose.
  - Remove the cap screws and detach the cover noting the position of the sealing diaphragm.

# Maintenance and Adjustment

## Rear Brake Fluid Level Inspection and Adjustment - Scrambler

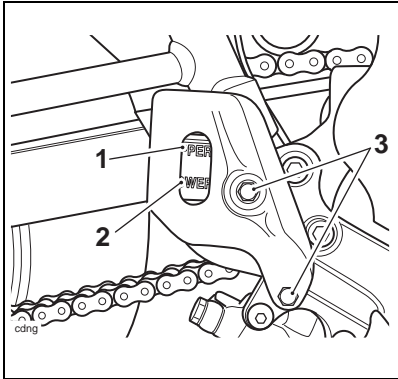

**1. Upper level, rear brake**

**2. Lower level, rear brake**

**3. Reservoir cover fasteners**

- positioned between the cap and reservoir body.
- Position the reservoir cover to the frame and secure with the two fasteners previously removed. Tighten the fasteners to **62 lb in (7 Nm)**.
- The rear brake fluid level is visible from the right hand side without removing the reservoir or cover.
- The brake fluid level in the rear reservoir must be kept between the upper and lower level lines, with the motorcycle supported in an upright position.
- To adjust the rear brake fluid level, remove the fasteners securing the reservoir cover to the frame and detach the reservoir cover.
- Remove the cap noting the position of the diaphragm inside.
- Fill the reservoir to the upper level line using DOT 4 fluid from a sealed container, with the motorcycle supported in an upright position.
- Install the reservoir cap ensuring that the diaphragm seal is correctly

# Maintenance and Adjustment

## Steering/Wheel Bearings

### Steering Inspection

Lubricate and inspect the condition of the steering head (steering) bearings in accordance with scheduled maintenance requirements.

#### Note:

- **Always inspect the wheel bearings at the same time as the steering bearings.**

### Warning

To prevent risk of injury from the motorcycle falling during the inspection, ensure that the motorcycle is stabilized and secured on the support.

Do not exert extreme force against each wheel or rock each wheel vigorously as this may cause the motorcycle to become unstable or cause injury by falling from its support.

Ensure that the position of the support block will not cause damage to the oil lines or oil filter beneath the sump.

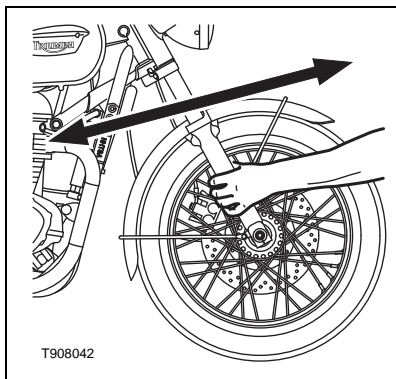

**Inspecting the Steering for Free Play**

### Inspection

- Position the motorcycle on level ground, in an upright position.
- Raise the front wheel off the ground.
- Hold the lower end of the front forks and try to move them forward and backward.
- If any free play can be detected, ask your authorized Triumph dealer to inspect and rectify any faults before riding.

### Warning

Riding the motorcycle with incorrectly adjusted or defective steering bearings may cause loss of motorcycle control and an accident.

- Remove the support and place the motorcycle on the side stand.

# Maintenance and Adjustment

## Wheel Bearings Inspection

If the wheel bearings in the front or rear wheel allow play in the wheel hub, are noisy, or if the wheel does not turn smoothly, have your authorized Triumph dealer inspect the wheel bearings.

The wheel bearings must be inspected at the intervals specified in the scheduled maintenance chart.

- Position the motorcycle on level ground, in an upright position.
- Raise the front wheel off the ground.
- Gently rock the top of the front wheel from side to side.
- If any free play can be detected, ask your authorized Triumph dealer to inspect and rectify any faults before riding.
- Reposition the lifting device and repeat for the rear wheel.

### Warning

Operation with worn or damaged wheel bearings may cause impaired handling and instability leading to loss of motorcycle control and an accident. If in doubt, have the motorcycle inspected by an authorized Triumph dealer before riding.

- Remove the support and place the motorcycle on the side stand.

## Front Suspension

### Front Fork Inspection

- Examine each fork stanchion for any sign of damage, scratching of the slider surface, or for oil leaks.
- If any damage or leakage is found, consult an authorized Triumph dealer.

To check that the forks operate smoothly:

- Position the motorcycle on level ground.
- While holding the handlebars and applying the front brake, pump the forks up and down several times.

### Note:

- **If roughness or excessive stiffness is detected, consult your authorized Triumph dealer.**

### Warning

Riding the motorcycle with defective or damaged suspension can damage the motorcycle, cause loss of motorcycle control and an accident.

# Maintenance and Adjustment

## Suspension Setting

Bonneville, Bonneville SE, Bonneville T100 and Scrambler models all have non-adjustable front suspension. Only the Thruxton is fitted with adjustable front suspension.

### Warning

Never attempt to dismantle any part of the suspension units, as all units contain pressurized oil. Skin and eye damage can result from contact with the pressurized oil.

Each graduation line should be set in alignment with the upper surface of the fork cap.

### Warning

Ensure that the adjusters are set to the same setting on both front suspension units. Settings which vary from left to right may affect handling and stability resulting in loss of motorcycle control, and an accident.

## Front Suspension Adjustment

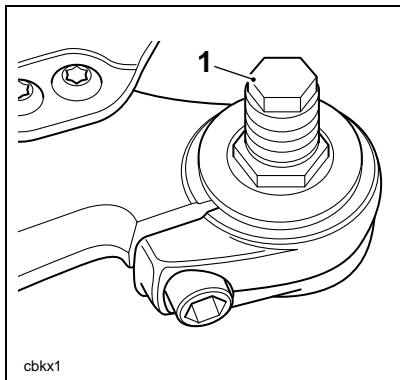

### 1. Front suspension pre-load adjuster - Thruxton only

To change the spring pre-load, rotate the adjuster clockwise (screw-in) to increase pre-load, or counter-clockwise (screw-out) to decrease pre-load. Always set the pre-load adjusters such that there are an equal number of graduation lines visible on both forks.

### Note:

- **The motorcycle is delivered from the factory with the spring pre-load adjuster set with 4 graduation lines visible.**

## Rear Suspension Adjustment

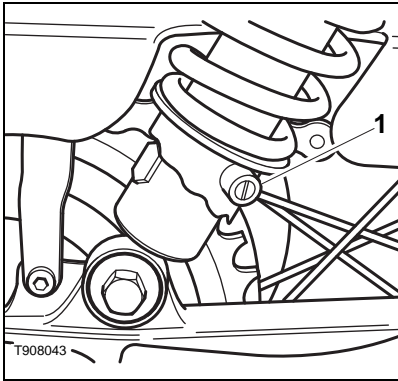

### 1. Rear suspension pre-load adjusters - all models

The standard rear suspension pre-load settings provide a comfortable ride and good handling characteristics for general, solo riding. The table (overleaf) shows suggested settings for rear suspension pre-load under differing load conditions.

To change the rear suspension spring pre-load setting, insert a suitable tool into the hole provided in the adjuster ring.

Turn the adjuster ring clockwise to increase spring pre-load, and counter-clockwise to decrease spring pre-load.

### Warning

Ensure that the adjusters are set to the same setting on both rear suspension units. Settings which vary from left to right may affect handling and stability resulting in loss of motorcycle control, and an accident.

## Suggested Suspension Settings

Front adjuster settings refer to the number of exposed graduation lines. There are seven adjuster positions in total. Position one gives the maximum amount of spring pre-load.

Rear adjuster settings are counted from one with position one being with the adjuster turned fully counter-clockwise. There are five adjuster positions in total. Position one gives the minimum amount of spring pre-load.

### Warning

Ensure that the correct balance between front and rear suspension is maintained. Suspension imbalance could significantly change handling characteristics leading to loss of control and an accident. Refer to the chart for further information or consult your Triumph dealer.

# Maintenance and Adjustment

## Bonneville T100, Thruxton and Scrambler

Loading Condition	Front Adjuster Position*	Rear Adjuster Position
Solo Riding - Softer	6	1
Solo Riding - Standard	4	2
Solo Riding - Firmer	2	3
Rider and Passenger	2	5

\* Thruxton only

## Bonneville and Bonneville SE

Loading Condition	Rear Adjuster Position
Solo Riding - Standard	1
Solo Riding - Firmer	3
Rider and Passenger	5

### Note:

- **The details given in the table are to be used as a guide only where the rider and passenger each weigh 198 lbs (90 kg) or less. Setting requirements should be increased for heavier riders and passengers according to personal preferences.**

## Tires

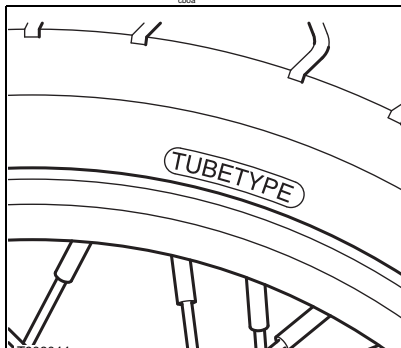

Typical Tire Marking

Bonneville T100, Thruxton and Scrambler models are fitted with spoked wheels which require a tire suitable for use with an inner tube.



### Warning

Failure to use an inner tube in a spoked wheel will cause deflation of the tire resulting in loss of motorcycle control and an accident.

Bonneville and Bonneville SE models are equipped with tubeless tires, valves and wheel rims. Use only tires marked 'TUBELESS' and tubeless valves on rims marked 'SUITABLE FOR TUBELESS TIRES'.



# Maintenance and Adjustment

## Warning

Do not install tube-type tires on tubeless rims. The bead will not seat and the tires could slip on the rims, causing rapid tire deflation that may result in a loss of vehicle control and an accident. Never install an inner tube inside a tubeless tire. This will cause friction inside the tire and the resulting heat build-up may cause the tube to burst resulting in rapid tire deflation, loss of vehicle control and an accident.

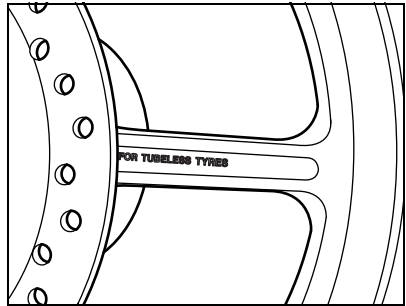

**Wheel Marking - Tubeless  
Wheel**

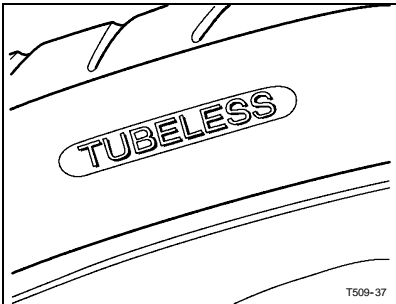

**Typical Tire Marking -  
Tubeless Tire**

## Warning

Inner tubes must only be used on motorcycles fitted with spoked wheels and with tires marked 'TUBE TYPE'.

Some brands of approved tire marked 'TUBELESS' may be suitable for use with an inner tube. Where this is the case, the tire wall will be marked with text permitting the fitment of an inner tube (see illustration).

Use of an inner tube with a tire marked 'TUBELESS', and NOT marked as suitable for use with an inner tube, or use of an inner tube on an alloy wheel marked 'SUITABLE FOR TUBELESS TIRES' will cause deflation of the tire resulting in loss of motorcycle control and an accident.

# Maintenance and Adjustment

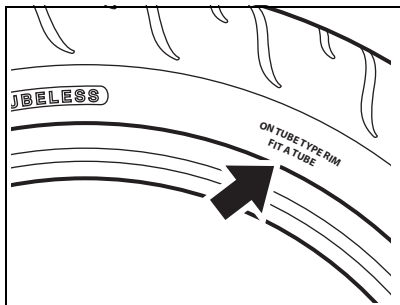

**Typical Tire Marking - Tubeless  
Tire Suitable For Use With An  
Inner Tube**

## Tire Inflation Pressures

Correct tire inflation pressures will provide maximum stability, rider comfort and tire life. Always check tire pressures before riding when the tires are cold. Check tire pressures daily and adjust if necessary (see Specification section for correct inflation pressures). Alternatively, ask your authorized Triumph dealer to inspect your wheels and tires.

### **Warning**

Incorrect tire inflation will cause abnormal tread wear and instability problems which may lead to loss of control and an accident. Under-inflation may result in the tire slipping on, or coming off the rim. Over-inflation will cause instability and accelerated tread wear. Both conditions are dangerous as they may cause loss of control leading to an accident.

## Tire Wear



As the tire tread wears down, the tire becomes more susceptible to punctures. It is estimated that 90% of all tire problems occur during the last 10% of tread life (90% worn). It is therefore not recommended to use tires until they are worn to their minimum.

## Minimum Recommended Tread Depth

In accordance with the periodic maintenance chart, measure the depth of the tread with a depth gauge, and replace any tire that has worn to, or beyond, the minimum allowable tread depth specified in the table below:

Under 80 mph (130 km/h)	0.08 in (2 mm)
Over 80 mph (130 km/h)	Rear 0.12 in (3 mm) Front 0.08 in (2 mm)

### **Warning**

This motorcycle must not be operated above the legal road speed limit except in authorized closed-course conditions.

# Maintenance and Adjustment

## Warning

Only operate this Triumph motorcycle at high speed in closed-course on-road competition or on closed-course racetracks. High-speed operation should only then be attempted by riders who have been instructed in the techniques necessary for high-speed riding and are familiar with the motorcycle's characteristics in all conditions. High-speed operation in any other circumstances is dangerous and will lead to loss of motorcycle control and an accident.

## Warning

Operation with excessively worn tires is hazardous and will adversely affect traction, stability and handling which may lead to loss of control and an accident.

When tires become punctured, leakage is often very slow. Always inspect tires very closely for punctures. Check the tires for cuts, embedded nails or other sharp objects. Operation with punctured or damaged tires will adversely affect stability and handling which may lead to loss of control or an accident.

Check the rims for dents or deformation and spokes for looseness and damage. Operation with damaged or defective wheels, spokes or tires is dangerous and loss of control or an accident could result.

Always consult your authorized Triumph dealer for tire replacement, or for a safety inspection of the wheels, spokes and tires.

## Tire Replacement

### Warning

Inner tubes must only be used on motorcycles fitted with spoked wheels and with tires marked 'TUBE TYPE'.

Use of an inner tube with a tire marked 'TUBELESS' and/or on an alloy wheel can lead to loss of motorcycle control and an accident.

### Warning

Do not install tube-type tires on tubeless rims. The bead will not seat and the tires could slip on the rims, causing rapid tire deflation that may result in a loss of vehicle control and an accident. Never install an inner tube inside a tubeless tire. This will cause friction inside the tire and the resulting heat build-up may cause the tube to burst resulting in rapid tire deflation, loss of vehicle control and an accident.

#### Note:

- **Some brands of approved tire marked 'TUBELESS' may be suitable for use with an inner tube. Where this is the case, the tire wall will be marked with text permitting the fitment of an inner tube.**

All Triumph motorcycles are carefully and extensively tested in a range of riding conditions to ensure that the most effective tire combinations are approved for use on each model. It is essential that approved tires and inner tubes (if installed) fitted in

## Maintenance and Adjustment

approved combinations, are used when purchasing replacement items. The use of non-approved tires and inner tubes, or approved tires and inner tubes in non-approved combinations, may lead to motorcycle instability, loss of control and an accident. See the Specification section for details of approved tire and inner tube combinations. Always have tires and inner tubes installed and balanced by your authorized Triumph dealer who has the necessary training and skills to ensure safe, effective mounting.

### Warning

If a tire or inner tube sustains a puncture, the tire and inner tube must be replaced. Failure to replace a punctured tire and inner tube, or operation with a repaired tire or inner tube can lead to instability, loss of motorcycle control or an accident.

### Warning

If tire or inner tube damage is suspected, such as after striking the curb, ask your authorized Triumph dealer to inspect the tire both internally and externally and to also inspect the inner tube. Remember, tire damage may not always be visible from the outside. Operation of the motorcycle with damaged tires could lead to loss of control and an accident.

### Warning

When replacement tires or inner tubes are required, consult your authorized Triumph dealer who will arrange for the tires and inner tubes to be selected, in a correct combination, from the approved list and fitted according to the tire and inner tube manufacturer's instructions.

When tires and inner tubes are replaced, allow time for the tires and inner tubes to seat to the rim (approximately 24 hours). During this seating period, ride cautiously as an incorrectly seated tire or inner tube could cause instability, loss of motorcycle control and an accident.

Initially, the new tires and inner tubes will not produce the same handling characteristics as the worn tires and inner tubes and the rider must allow adequate riding distance (approximately 100 miles) to become accustomed to the new handling characteristics.

24 hours after fitting, the tire pressures must be checked and adjusted, and the tires and inner tubes examined for correct seating. Rectification must be carried out as necessary.

The same checks and adjustments must also be carried out when 100 miles have been travelled after fitting.

Use of a motorcycle with incorrectly seated tires or inner tubes, incorrectly adjusted tire pressures, or when not accustomed to its handling characteristics may lead to loss of motorcycle control and an accident.

# Maintenance and Adjustment

## Warning

Tires and inner tubes that have been used on a rolling road dynamometer may become damaged. In some cases, the damage may not be visible on the external surface of the tire.

Tires and inner tubes must be replaced after such use as continued use of a damaged tire or inner tube may lead to instability, loss of motorcycle control and an accident.

## Warning

Accurate wheel balance is necessary for safe, stable handling of the motorcycle. Do not remove or change any wheel balance weights. Incorrect wheel balance may cause instability leading to loss of control and an accident.

When wheel balancing is required, such as after tire or inner tube replacement, see your authorized Triumph dealer.

Only use self-adhesive weights. Clip on weights may damage the wheel, tire or inner tube resulting in tire deflation, loss of motorcycle control and an accident.

## Battery



## Warning

Under some circumstances, the battery can give off explosive gases; keep sparks, flames and cigarettes away. Provide adequate ventilation when charging or using the battery in an enclosed space.

The battery contains sulphuric acid (battery acid). Contact with skin or eyes may cause severe burns. Wear protective clothing and a face shield.

If battery acid gets on your skin, flush with water immediately.

If battery acid gets in your eyes, flush with water for at least 15 minutes and SEEK MEDICAL ATTENTION IMMEDIATELY.

If battery acid is swallowed, drink large quantities of water and SEEK MEDICAL ATTENTION IMMEDIATELY.

KEEP BATTERY ACID OUT OF THE REACH OF CHILDREN.

## Warning

The battery contains harmful materials. Always keep children away from the battery whether or not it is fitted in the motorcycle.

Do not jump start the battery, touch the battery cables together or reverse the polarity of the cables as any of these actions may cause a spark which would ignite battery gases causing a risk of personal injury.

# Maintenance and Adjustment

## Battery Disposal

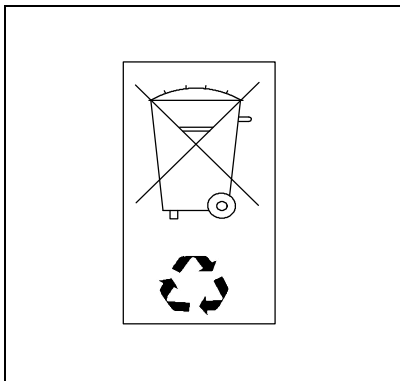

Should the battery ever require replacement, the original battery must be handed to a recycling agent who will ensure that the dangerous substances from which the battery is manufactured do not pollute the environment.

## Battery Removal

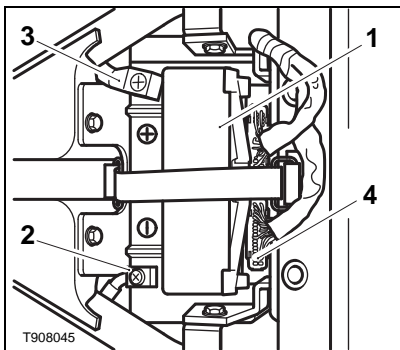

1. Battery
2. Negative (-) terminal
3. Positive (+) terminal
4. Engine control module (ECM)

- Remove the seat as described in the General Information section.
- Disconnect the battery leads, negative (black) lead first.
- Remove the battery strap.
- Take the battery out of the case.

### Note:

- **The Engine Control Module (ECM) is located at the rear of the battery tray and is secured to the motorcycle by the battery. Ensure the ECM is not disturbed during the battery removal or installation process.**

### Warning

Ensure that the battery terminals do not touch any part of the motorcycle as this may cause a short circuit or spark which would ignite battery gases causing a risk of personal injury and damage to the motorcycle.

# Maintenance and Adjustment

---

## Battery Maintenance

Clean the battery using a clean, dry cloth. Be sure that the cable connections are clean.



### Warning

The battery acid is corrosive and poisonous and will cause damage to unprotected skin. Never swallow battery acid or allow it to come into contact with the skin. To prevent injury, always wear eye and skin protection when handling the battery.

The battery is a sealed type and will not require any maintenance other than checking the Voltage and routine recharging, such as during storage.

It is not possible to adjust the battery acid level in the battery; the sealing strip must not be removed.

## Battery Discharge



### Caution

The charge level in the battery must be maintained to maximise battery life.

Failure to maintain the battery charge level could cause serious internal damage to the battery.

Under normal conditions, the motorcycle charging system will keep the battery fully charged. However, if the motorcycle is unused, the battery will gradually discharge due to a normal process called self discharge; the clock, engine control module (ECM) memory, high ambient temperatures, or the addition of electrical security systems or other electrical accessories will all increase this rate

of battery discharge. Disconnecting the battery from the motorcycle during storage will reduce the rate of discharge.

## Battery Discharge During Storage and Infrequent Use of the Motorcycle

During storage or infrequent use of the motorcycle, inspect the battery Voltage weekly using a digital multimeter. Follow the manufacturer's instructions supplied with the meter. Should the battery Voltage fall below 12.7 Volts, the battery should be charged (see page 96).

Allowing a battery to discharge or leaving it discharged for even a short period of time causes sulphation of the lead plates. Sulphation is a normal part of the chemical reaction inside the battery, however over time the sulphate can crystallise on the plates making recovery difficult or impossible. This permanent damage is not covered by the motorcycle warranty, as it is not due to a manufacturing defect.

Keeping the battery fully charged reduces the likelihood of it freezing in cold conditions. Allowing a battery to freeze will cause serious internal damage to the battery.

# Maintenance and Adjustment

---

## Battery Charging

For help in selecting a battery charger, checking the battery Voltage or battery charging, contact your local authorized Triumph dealer.

### **Warning**

The battery gives off explosive gases; keep sparks, flames and cigarettes away. Provide adequate ventilation when charging or using the battery in an enclosed space.

The battery contains sulphuric acid (battery acid). Contact with skin or eyes may cause severe burns. Wear protective clothing and a face shield.

If battery acid gets on your skin, flush with water immediately.

If battery acid gets in your eyes, flush with water for at least 15 minutes and **SEEK MEDICAL ATTENTION IMMEDIATELY.**

If battery acid is swallowed, drink large quantities of water and **SEEK MEDICAL ATTENTION IMMEDIATELY.**

**KEEP BATTERY ACID OUT OF THE REACH OF CHILDREN.**

### **Caution**

Do not use an automotive quick charger as it may overcharge and damage the battery.

Should the battery Voltage fall below 12.7 Volts, the battery should be charged using a Triumph approved battery charger. Always remove the battery from the motorcycle and follow the instructions supplied with the battery charger.

For extended periods of storage (beyond two weeks) the battery should be removed from the motorcycle and kept charged using a Triumph approved maintenance charger.

Similarly, should the battery charge fall to a level where it will not start the motorcycle, remove the battery from the motorcycle before charging.



# Maintenance and Adjustment

## Battery Installation

### Warning

Ensure that the battery terminals do not touch any part of the motorcycle as this may cause a short circuit or spark which would ignite battery gases causing a risk of personal injury and damage to the motorcycle.

- Ensure the Engine Control Module (ECM) and its cover are correctly located behind the battery.
- Place the battery in the battery case.
- Reconnect the battery leads, positive (red) lead first.
- Apply a light coat of grease to the terminals to prevent corrosion.
- Cover the positive terminal with the protective cap.
- Install the battery strap.
- Install the seat as described in the General Information section.

## Fuses

### Fuse Location

Fuses are arranged in the fuse box located behind the right hand side cover.

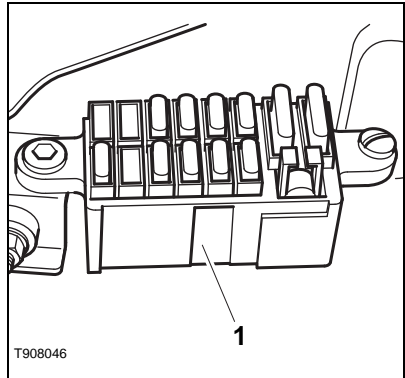

### 1. Fuse box

### Fuse Replacement

If a fuse fails during operation, inspect the electrical system to determine the cause, and then replace it with a new fuse of the same (correct) current rating.

### Warning

Always replace blown fuses with new ones of the correct current rating (as specified on the fuse box cover) and never use a fuse of higher rating.

Use of an incorrectly rated fuse could lead to an electrical problem, resulting in motorcycle damage, loss of motorcycle control and an accident.

# Maintenance and Adjustment

## Fuse Identification

The fuses can be identified by a number moulded into the fusebox housing, adjacent to each fuse, as shown below. These numbers correspond to the numbers given in the table overleaf. Fuses without an identification number are spare, and should be replaced if used.

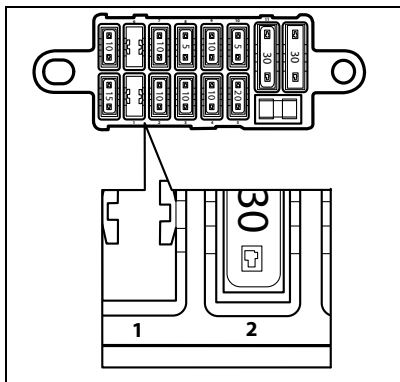

Fuse Identification

A blown fuse is indicated when all of the systems protected by that fuse become inoperative. When checking for a blown fuse, use the table below to establish which fuse has blown.

Fuse No	Circuits Protected	Fuse Rating (Amp.)
1	Not Used	-
2	Alarm, Diagnostic Connector	10
3	Accessory Socket, GPS	10
4	Not Used	-
5	Engine Management System	20
6	Ignition Switch Main Feed, Instrumentation Illumination	10
7	Turn Signals, Brake Light, Horn	10
8	Position Light	5
9	Dip/Main Beam	10
10	Position Lights	5
11	Main Battery Fuse	30

### Note:

- **Only 30, 20 and 10 amp. spare fuses are provided in the fuse box. A spare 5 amp. fuse must also be carried on the motorcycle.**

# Maintenance and Adjustment

## Headlight

### ⚠ Warning

Adjust road speed to suit the visibility and weather conditions in which the motorcycle is being operated.

Ensure that the beam is adjusted to illuminate the road surface sufficiently far ahead, but without blinding oncoming traffic. An incorrectly adjusted headlight may impair visibility causing loss of motorcycle control and an accident.

### ⚠ Warning

Never attempt to adjust the headlight beam when the motorcycle is in motion.

Any attempt to adjust the headlight beam when the motorcycle is in motion may result in loss of control and an accident.

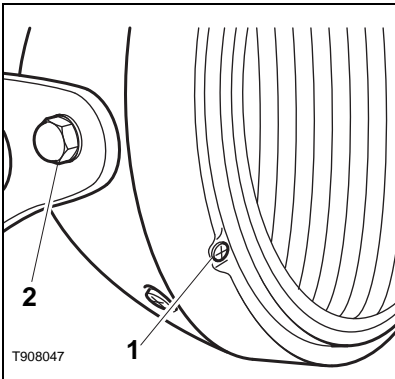

1. Horizontal adjustment screw
2. Vertical adjustment fasteners

## Headlight Adjustment

- Horizontal adjustment of the headlight beam is controlled by the screw in the rim of the headlight. Turn the screw clockwise to move the beam to the left and counter-clockwise to move the beam to the right.
- Vertical adjustment of the headlight beam is controlled by loosening the headlight assembly mounting bolts and altering the position of the headlight assembly.
- Re-tighten the fasteners after adjustment.

### Note:

- **Changes made to the horizontal adjusters will marginally change the vertical setting of the headlight beam. Always allow for additional adjustment to compensate for this factor.**

# Maintenance and Adjustment

## Headlight/Position Light Bulb Replacement

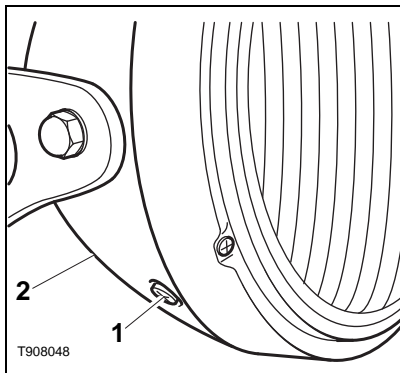

1. Headlight rim screws (1 of 2)
2. Headlight bowl

- Disconnect the battery, negative (black) lead first.
- Remove the headlight rim screws.
- Detach the headlight and rim assembly from the headlight bowl.
- While supporting the light unit, disconnect the multi-pin electrical connector from the headlight bulb and the two spade connectors from the position light.
- Remove the rubber dust cover.
- Unhook the headlight bulb's wire retainer.
- The headlight bulb can now be removed.
- To remove the position light bulb, detach the bulb holder from the headlight body and release the bulb.

- Installation is the reversal of removal.

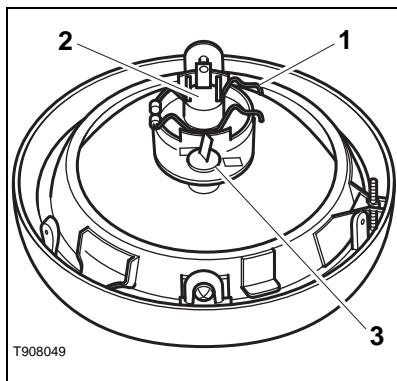

1. Wire retainer
2. Headlight bulb
3. Position light

### Warning

Do not reconnect the battery until the assembly process has been completed. Premature battery reconnection could result in ignition of the battery gases causing risk of injury.

### Warning

The bulb becomes hot during use. Always allow sufficient time for the bulb to cool before handling.

### Caution

When reconnecting the battery, connect the positive (red) lead first.

# Maintenance and Adjustment

## Brake/Tail Light/License Plate Light

### Brake/Tail Light

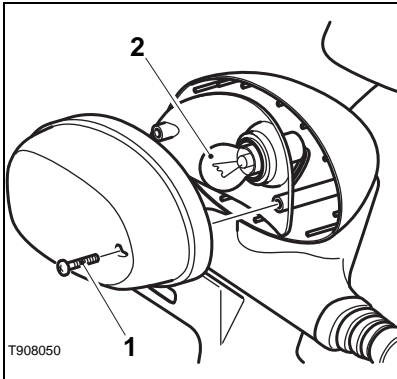

1. Brake/tail light lens screws
2. Bulb

### Bulb Replacement

- Remove the screws securing the brake/tail light lens.
- Remove the lens.
- The bulb is a bayonet type. To remove the bulb, gently press inwards and twist counter-clockwise.
- Installation is the reversal of removal.

## Turn Signal Lights

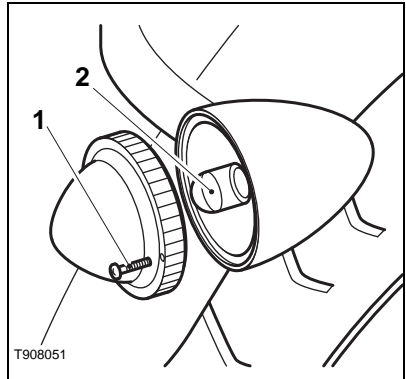

1. Turn signal lens screw
2. Bulb

### Bulb Replacement

- The lens on each turn signal light is held in place by screws.
- Remove the screws and remove the lens to gain access to the bulb for replacement.

# Maintenance and Adjustment

---

## Cleaning

Frequent, regular cleaning is an essential part of the maintenance of your motorcycle. If regularly cleaned, the appearance will be preserved for many years. Cleaning with cold water containing an automotive cleaner is essential at all times but particularly so after exposure to sea breezes, sea water, dusty or muddy roads and in winter when roads are treated for ice and snow. Do not use household detergent as the use of such products will lead to premature corrosion.

Although, under the terms of your motorcycle warranty, cover is provided against the corrosion of certain items, the owner is expected to observe this reasonable advice which will safeguard against corrosion and enhance the appearance of the motorcycle.

## Preparation for Washing

Before washing, precautions must be taken to keep water off the following places:

- Rear opening of the exhausts: Cover with a plastic bag secured with rubber bands.
- Clutch and brake levers, switch housings on the handlebar: Cover with plastic bags.
- Ignition switch and steering lock: Cover the keyholes with tape.

Remove any items of jewellery such as rings, watches, zips or belt buckles, which may scratch or otherwise damage painted or polished surfaces.

Use separate cleaning sponges or cleaning cloths for washing painted/polished surfaces and chassis areas. Chassis areas (such as wheels and under mudguards) will be exposed to more abrasive road grime and

dust, which may then scratch painted or polished surfaces, if the same sponges or cleaning cloths are used.

## Where to be Careful

Avoid spraying water with any great force near the following places:

- Instruments;
- Brake cylinders and brake calipers;
- Under the fuel tank;
- Drive chain and steering head bearings.

### **Caution**

Do not spray any water at or behind the left hand side panel. The engine's air intake duct is located behind the left hand side panel and any water sprayed in this area could enter the airbox and engine, causing damage to both items.

### **Caution**

Use of high-pressure spray washers is not recommended. When using pressure washers, water may be forced into bearings and other components causing premature wear from corrosion and loss of lubrication.

## Note:

- **Use of soaps that are highly alkaline will leave a residue on painted surfaces, and may also cause water spotting. Always use a low alkaline soap to aid the cleaning process.**

# Maintenance and Adjustment

---

## After Washing

- Remove the rubber bands, plastic bags and tape, and clear the air intakes.
- Lubricate the pivots, bolts and nuts.
- Test the brakes before motorcycle operation.
- Start the engine and run it for 5 minutes. Ensure adequate ventilation for the exhaust fumes.
- Use a dry cloth to absorb water residue. Do not allow water to stand on the machine as this will lead to corrosion.



### Warning

Never wax or lubricate the brake discs. Loss of braking power and an accident could result. Clean the disc with a proprietary brand of oil-free brake disc cleaner.

## Unpainted Aluminum Items

- Items such as brake and clutch levers must be correctly cleaned to preserve their appearance.
- Use a proprietary brand of aluminum cleaner which does not contain abrasive or caustic elements.
- Clean aluminum items regularly, in particular after use in inclement weather, where the components must be hand washed and dried each time the machine is used.
- On Thruxton and Scrambler models only, additional care is required to ensure that the finished edges of the cylinder head fins are cleaned and dried each time the motorcycle is used.
- Warranty claims due to inadequate maintenance will not be allowed.

# Maintenance and Adjustment

## Cleaning of Exhaust System

All parts of the exhaust system of your motorcycle must be cleaned regularly to avoid a deterioration of its appearance. These instructions can be applied to chrome, brushed stainless steel and carbon fiber components alike.

### Note:

- **The exhaust system must be cool before washing to prevent water spotting.**

### Washing

- Prepare a mixture of cold water and mild automotive cleaner. Do not use a high alkaline content soap as commonly found at commercial car washes because it leaves a residue.
- Wash the exhaust system with a soft cloth. Do not use an abrasive scouring pad or steel wool. They will damage the finish.
- Rinse the exhaust system thoroughly.
- Ensure no soap or water enters the exhausts.

### Drying

- Dry the exhaust system completely with a soft cloth. Do not run the engine to dry the system or spotting will occur.

### Protecting

- When the exhaust system is dry, rub 'Motorex 645 Clean and Protect' into the surface.



### Caution

The use of products containing silicone will cause discoloration of the chrome and must not be used. Similarly, the use of abrasive cleaners and polishes will damage the system and must not be used.

- It is recommended that regular protection be applied to the system as this will both protect and enhance the system's appearance.

## Accessory Windshield Cleaning



Clean the windshield with a solution of mild soap or detergent and lukewarm water. After cleaning, rinse well and

then dry with a soft, lint free cloth.



### Caution

Products such as window cleaning fluids, insect remover, rain repellent, scouring compounds, gasoline or strong solvents such as alcohol, acetone, carbon tetrachloride, etc. will damage the windshield. Never allow these products to contact the windshield.

If the transparency of the windshield is reduced by scratches or oxidation which cannot be removed, the windshield must be replaced.



## Maintenance and Adjustment

---

### **Warning**

Never attempt to clean the windshield while the motorcycle is in motion as releasing the handlebars may cause loss of vehicle control and an accident.

Operation of the motorcycle with a damaged or scratched windshield will reduce the rider's forward vision. Any such reduction in forward vision is dangerous and may lead to an accident causing injury or death.

### **Caution**

Corrosive chemicals such as battery acid will damage the windshield. Never allow corrosive chemicals to contact the windshield.

## Maintenance and Adjustment

---

This page intentionally left blank

## STORAGE

### Preparation for Storage

Clean the entire vehicle thoroughly.

Fill the fuel tank with the correct grade of unleaded fuel and add a fuel stabilizer (if available), following the fuel stabilizer manufacturer's instructions.

 **Warning**

Gasoline (fuel) is extremely flammable and can be explosive under certain conditions. Turn the ignition switch off. Do not smoke. Make sure the area is well ventilated and free from any source of flame or sparks; this includes any appliance with a pilot light.

Remove the spark plug from each cylinder and put several drops (0.16 fl oz (5 ml)) of engine oil into each cylinder. Cover the spark plug holes with a piece of cloth or rag. With the engine stop switch in the RUN position, push the starter button for a few seconds to coat the cylinder walls with oil. Install the spark plugs, tightening to **15 lbf ft (20 Nm)**.

Change the engine oil and filter (see page 67).

Check and if necessary correct the tire pressures (see page 116).

Set the motorcycle on a stand so that both wheels are raised off the ground. (If this cannot be done, put boards under the front and rear wheels to keep dampness away from the tires.)

Spray rust inhibiting oil (there are a host of products on the market and your dealer will be able to offer you local advice) on all

unpainted metal surfaces to prevent rusting. Prevent oil from getting on rubber parts, brake discs or in the brake calipers.

Lubricate and if necessary adjust the drive chain (see page 75).

Remove the battery, and store it where it will not be exposed to direct sunlight, moisture, or freezing temperatures. During storage it should be given a slow charge (one ampere or less) about once every two weeks (see page 93).

### Preparation after Storage

Install the battery (if removed) (see page 93).

If the motorcycle has been stored for more than four months, change the engine oil (see page 67).

Check all the points listed in the Daily Safety Checks section (see page 43).

Before starting the engine, remove the spark plugs from each cylinder.

Put the side stand down.

Crank the engine on the starter motor several times until the oil pressure light goes out.

Replace the spark plugs, tightening to **15 lbf ft (20 Nm)**, and start the engine.

Check and if necessary correct the tire pressures (see page 116).

Check the brakes for correct operation.

Test ride the motorcycle at low speeds.

## Storage

---

This page intentionally left blank

## SPECIFICATIONS

	<b>Bonneville and Bonneville SE</b>	<b>Bonneville T100</b>
<b>Performance</b>		
Maximum Power	67.2 hp (68.1 PS) @ 7,400 rpm	67.2 hp (68.1 PS) @ 7,400 rpm
Maximum Torque	50.4 lbf ft (68.4 Nm) @ 5,800 rpm	50.4 lbf ft (68.4 Nm) @ 5,800 rpm
<b>Dimensions</b>		
Overall Length	83.2 in (2,115 mm)	87.7 in (2,230 mm)
Overall Width	31.1 in (790 mm)	33.0 in (840 mm)
Overall Height	44.4 in (1,130 mm)	43.3 in (1,100 mm)
Wheelbase	58.6 in (1,490 mm)	59.0 in (1,500 mm)
Seat Height	29.1 in (740 mm)	30.5 in (775 mm)
Dry Weight	440 lb (200 kg)	452 lb (205 kg)
Maximum Payload (rider, passenger and accessories)	440 lb (200 kg)	440 lb (200 kg)

# Specifications

---

<b>Engine</b>	<b>Bonneville and Bonneville SE</b>	<b>Bonneville T100</b>
Type.....	Air cooled parallel twin cylinder 360° firing angle	Air cooled parallel twin cylinder 270° firing angle
Displacement.....	52.7 cu in (865 cc)	52.7 cu in (865 cc)
Bore x Stroke .....	3.54 x 68 in (90 x 68 mm)	3.54 x 68 in (90 x 68 mm)
Compression Ratio .....	10.2:1	10.2:1
Cylinder Numbering.....	Left to Right	Left to Right
Sequence.....	1-2	1-2
Type.....	Air cooled parallel twin cylinder 360° firing angle	Air cooled parallel twin cylinder 270° firing angle
Firing Order .....	1-2	1-2
Starting System.....	Electric Starter	Electric Starter
<b>Lubrication</b>		
Lubrication System .....	Wet-sump	Wet-sump
Engine Oil Capacity Guidelines		
(dry fill).....	1.18 US gal (4.5 liters)	1.18 US gal (4.5 liters)
(oil and filter changes).....	1.0 US gal (3.8 liters)	1.0 US gal (3.8 liters)
(oil change only) .....	0.87 US gal (3.3 liters)	0.87 US gal (3.3 liters)

**Note: Always refer to sight glass marking for correct level.**

## Specifications

---

	<b>Thruxton</b>	<b>Scrambler</b>
<b>Performance</b>		
Maximum Power .....	67.2 hp (68.1 PS) @ 7,400 rpm	57.7 (58.5 PS) @ 6,800 rpm
Maximum Torque.....	50.4 lbf ft (68.4 Nm) @ 5,800 rpm	49.6 lbf ft (67.3 Nm) @ 4,750 rpm
<b>Dimensions</b>		
Overall Length .....	84.6 in (2,150 mm)	87.2 in (2,215 mm)
Overall Width .....	37.4 in (950 mm)	34.0 in (865 mm)
Overall Height.....	44.1 in (1,120 mm)	47.3 in (1,202 mm)
Wheelbase.....	59.4 in (1,510 mm)	59.0 in (1,500 mm)
Seat Height .....	31.1 in (790 mm)	32.5 in (825 mm)
Dry Weight .....	452 lbs (205 kg)	452 lbs (205 kg)
Maximum Payload .....	440 lbs (200 kg)	440 lbs (200 kg)
(rider, passenger and accessories)		

# Specifications

---

	<b>Thruxton</b>	<b>Scrambler</b>
<b>Engine</b>		
Type.....	Air cooled parallel twin cylinder 360° firing angle	Air cooled parallel twin cylinder 270° firing angle
Displacement.....	52.7 cu in (865 cc)	52.7 cu in (865 cc)
Bore x Stroke .....	3.54 x 68 in (90 x 68 mm)	3.54 x 68 in (90 x 68 mm)
Compression Ratio .....	10.2:1	9.2:1
Cylinder Numbering.....	Left to Right	Left to Right
Sequence.....	1-2	1-2
Firing Order .....	1-2	1-2
Starting System.....	Electric Starter	Electric Starter
<b>Lubrication</b>		
Lubrication System.....	Wet-sump	Wet-sump
Engine Oil Capacity Guidelines		
(dry fill).....	1.18 US gal (4.5 liters)	1.18 US gal (4.5 liters)
(oil and filter changes).....	1.0 US gal (3.8 liters)	1.0 US gal (3.8 liters)
(oil change only) .....	0.87 US gal (3.3 liters)	0.87 US gal (3.3 liters)

**Note: Always refer to sight glass marking for correct level.**



## All Models

### Fuel System

Type .....	Sequential electronic fuel injection
Fuel Pump .....	Submerged electric
Fuel Pressure .....	43.5 psi (3.0 bar)

### Fuel

Type .....	87 (R+M)/2 unleaded (91 RON unleaded (minimum octane rating))
Tank Capacity .....	4.4 US gal (16.6 liters)

### Emissions Control Equipment

Type .....	Twin oxidation catalysts and pre-catalysts, with secondary air injection
------------	---

### Ignition

Ignition System .....	Digital electronic
Spark Plug .....	NGK DPR8EA-9
Gap .....	0.031 - 0.035 in (0.8 - 0.9 mm)

# Specifications

---

	<b>Bonneville and Bonneville SE</b>	<b>Bonneville T100</b>
<b>Transmission</b>		
Transmission Type.....	5 Speed, Constant Mesh	5 Speed, Constant Mesh
Clutch Type.....	Wet, Multi-Plate	Wet, Multi-Plate
Primary Drive .....	Gear	Gear
Final Drive .....	Chain DID 525 VM2 104 Link Endless	Chain DID 525 VM2 104 Link Endless
Primary Drive Ratio.....	1.74:1 (62/108)	1.74:1 (62/108)
Final Drive Ratio .....	2.39:1 (18/43)	2.39:1 (18/43)
Gear Ratio:		
1st .....	2.73:1 (41/15)	2.73:1 (41/15)
2nd .....	1.95:1 (37/19)	1.95:1 (37/19)
3rd.....	1.55:1 (34/22)	1.55:1 (34/22)
4th.....	1.29:1 (31/24)	1.29:1 (31/24)
5th.....	1.07:1 (29/27)	1.07:1 (29/27)

# Specifications

---

	<b>Thruxton</b>	<b>Scrambler</b>
<b>Transmission</b>		
Transmission Type.....	5 Speed, Constant Mesh	5 Speed, Constant Mesh
Clutch Type.....	Wet, Multi-Plate	Wet, Multi-Plate
Primary Drive.....	Gear	Gear
Final Drive.....	Chain DID 525 VM2 106 Link Endless	Chain DID 525 VM2 104 Link Endless
Primary Drive Ratio.....	1.74:1 (62/108)	1.74:1 (62/108)
Final Drive Ratio.....	2.39:1 (18/43)	2.39:1 (18/43)
Gear Ratio:		
1st.....	2.73:1 (41/15)	2.73:1 (41/15)
2nd.....	1.95:1 (37/19)	1.95:1 (37/19)
3rd.....	1.55:1 (34/22)	1.55:1 (34/22)
4th.....	1.29:1 (31/24)	1.29:1 (31/24)
5th.....	1.07:1 (29/27)	1.07:1 (29/27)

# Specifications

	Bonneville and Bonneville SE	Bonneville T100
<b>Tires</b>		
<b>Tire Pressures (Cold)</b>		
Front		
Solo .....	33 lb/in <sup>2</sup> (2.27 bar)	33 lb/in <sup>2</sup> (2.27 bar)
Fully Laden .....	33 lb/in <sup>2</sup> (2.27 bar)	33 lb/in <sup>2</sup> (2.27 bar)
Rear		
Solo .....	41 lb/in <sup>2</sup> (2.82 bar)	41 lb/in <sup>2</sup> (2.82 bar)
Fully Laden .....	41 lb/in <sup>2</sup> (2.82 bar)	41 lb/in <sup>2</sup> (2.82 bar)
Option 1		
Front .....	Metzeler ME Z4 110/70-17	Metzeler ME 33 Laser 100/90-19
Rear .....	Metzeler ME Z2 130/80-R17	Metzeler ME Z2 130/80-R17
Option 2		
Front .....	N/A	N/A
Rear .....	N/A	N/A

## **Warning**

Use recommended tire options **ONLY** in the combinations given. Do not mix tires from different manufacturers or mix different specification tires from the same manufacturers.

## Specifications

	Thruxton	Scrambler
<b>Tires</b>		
<b>Tire Pressures (Cold)</b>		
Front		
Solo .....	33 lb/in <sup>2</sup> (2.27 bar)	30 lb/in <sup>2</sup> (2.07 bar)
Fully Laden .....	38 lb/in <sup>2</sup> (2.62 bar)	30 lb/in <sup>2</sup> (2.07 bar)
Rear		
Solo .....	41 lb/in <sup>2</sup> (2.82 bar)	41 lb/in <sup>2</sup> (2.34 bar)
Fully Laden .....	41 lb/in <sup>2</sup> (2.62 bar)	41 lb/in <sup>2</sup> (2.34 bar)
Option 1		
Front .....	Metzeler ME33 100/90-18	Bridgestone TW101 100/90-19
Rear .....	Metzeler MEZ2 130/80-17	Bridgestone TW42 130/80-17

### **Warning**

Use recommended tire options **ONLY** in the combinations given. Do not mix tires from different manufacturers or mix different specification tires from the same manufacturers.

# Specifications

---

	<b>Bonneville and Bonneville SE</b>	<b>Bonneville T100</b>
<b>Electrical Equipment</b>		
Battery .....	12V 10 Ah	12V 10 Ah
Alternator .....	24A @ 2,000 rpm 26A @ 4,000 rpm	24A @ 2,000 rpm 26A @ 4,000 rpm
Headlight .....	12V 60/55W Halogen H4	12V 60/55W Halogen H4
Tail/Brake Light .....	12V 5/21W	12V 5/21W
Turn signal Lights .....	12V 10W	12V 10W
<b>Frame</b>		
Rake .....	27.5°	29°
Trail .....	4.19 in (106.5 mm)	4.6 in (117 mm)
<b>Tightening Torques</b>		
Oil Filter .....	7 lbf ft (10 Nm)	7 lbf ft (10 Nm)
Sump Drain Plug .....	18 lbf ft (25 Nm)	18 lbf ft (25 Nm)
Spark Plug .....	15 lbf ft (20 Nm)	15 lbf ft (20 Nm)
<b>Fluids and Lubricants</b>		
<b>Engine Oil</b>		
Semi or fully synthetic 10W/40 or 15W/50 motorcycle engine oil which meets specification API SH or higher AND JASO MA, such as	Mobil 1 Racing 4T (fully synthetic) or Mobil Extra 4T (semi synthetic)	
Brake and Clutch Fluid .....	Mobil Universal Brake and Clutch Fluid DOT 4	
Bearings and Pivots .....	Mobil Grease XHP 222	
Drive Chain .....	Mobil Chain Spray	
or .....	Mobilube HD 80	

# Specifications

---

	<b>Thruxton</b>	<b>Scrambler</b>
<b>Electrical Equipment</b>		
Battery	12V 10 Ah	12V 10 Ah
Alternator	24A @ 2,000 rpm 26A @ 4,000 rpm	24A @ 2,000 rpm 26A @ 4,000 rpm
Headlight	12V 60/55W Halogen H4	12V 60/55W Halogen H4
Tail/Brake Light	12V 5/21W	12V 5/21W
Turn signal Lights	12V 21W	12V 10W
<b>Frame</b>		
Rake	27°	27.8°
Trail	3.8 in (97 mm)	4.1 in (105 mm)
<b>Tightening Torques</b>		
Oil Filter	7 lbf ft (10 Nm)	7 lbf ft (10 Nm)
Sump Drain Plug	18 lbf ft (25 Nm)	18 lbf ft (25 Nm)
Spark Plug	15 lbf ft (20 Nm)	15 lbf ft (20 Nm)
<b>Fluids and Lubricants</b>		
<b>Engine Oil</b>		
Semi or fully synthetic 10W/40 or 15W/50 motorcycle engine oil which meets specification API SH or higher AND JASO MA, such as	Mobil 1 Racing 4T (fully synthetic) or Mobil Extra 4T (semi synthetic)	
Brake and Clutch Fluid	Mobil Universal Brake and Clutch Fluid DOT 4	
Bearings and Pivots	Mobil Grease XHP 222	
Drive Chain	Mobil Chain Spray	
or	Mobilube HD 80	

## Specifications

---

This page intentionally left blank



<b>A</b>		<b>E</b>	
Accessories & Loading . . . . .	<b>55</b>	Engine	
Accessory Windshield Cleaning . . . . .	<b>104</b>	Engine Stop Switch . . . . .	<b>32</b>
<b>B</b>		Serial Number . . . . .	<b>21</b>
Battery		To Start The Engine . . . . .	<b>46</b>
Disposal . . . . .	<b>94</b>	To Stop the Engine . . . . .	<b>46</b>
Maintenance . . . . .	<b>95</b>	Engine Oil . . . . .	<b>66</b>
Removal . . . . .	<b>94</b>	Disposal of Used Engine Oil . . . . .	<b>69</b>
Brake/Tail Light . . . . .	<b>101</b>	Level Inspection . . . . .	<b>66</b>
Brakes . . . . .	<b>78</b>	Oil Specification & Grade . . . . .	<b>69</b>
Brake and Clutch Lever Adjusters . . . . .	<b>34</b>	<b>F</b>	
Brake Fluid . . . . .	<b>79</b>	Filling the Fuel Tank . . . . .	<b>38</b>
Brake Light Switches . . . . .	<b>79</b>	Front Suspension . . . . .	<b>85</b>
Brake Pad Wear Compensation . . . . .	<b>79</b>	Fuel . . . . .	<b>35, 113</b>
Brake Pad Wear Inspection . . . . .	<b>78</b>	Filling the Fuel Tank . . . . .	<b>38</b>
Braking . . . . .	<b>49</b>	Fuel Grade . . . . .	<b>35</b>
Rear Brake Fluid Level . . . . .	<b>82, 83</b>	Fuel System . . . . .	<b>113</b>
Breaking-In . . . . .	<b>42</b>	Fuel Tank Cap . . . . .	<b>37</b>
<b>C</b>		Refuelling . . . . .	<b>37</b>
Cleaning . . . . .	<b>102</b>	Fuses . . . . .	<b>97</b>
After Washing . . . . .	<b>103</b>	Fuse Identification . . . . .	<b>98</b>
Exhaust System . . . . .	<b>104</b>	Fuse Location . . . . .	<b>97</b>
Preparation for Washing . . . . .	<b>102</b>	Fuse Replacement . . . . .	<b>97</b>
Unpainted Aluminum Items . . . . .	<b>103</b>	<b>G</b>	
Where to be Careful . . . . .	<b>102</b>	Gears	
Clutch . . . . .	<b>72</b>	Moving Off/Shifting Gears . . . . .	<b>48</b>
Adjustment . . . . .	<b>73</b>	<b>H</b>	
Inspection . . . . .	<b>73</b>	Headlight . . . . .	<b>99, 100</b>
<b>D</b>		Adjustment . . . . .	<b>99</b>
Daily Safety Checks . . . . .	<b>43</b>	Position Light Bulb Replacement . . . . .	<b>100</b>
Drive Chain . . . . .	<b>74</b>	Heat Shield . . . . .	<b>35</b>
Adjustment . . . . .	<b>76</b>	High Speed Operation . . . . .	<b>52</b>
Chain Free-movement . . . . .	<b>75</b>	<b>I</b>	
Chain Lubrication . . . . .	<b>75</b>	Ignition . . . . .	<b>113</b>
Chain Wear Inspection . . . . .	<b>77</b>	Key . . . . .	<b>29</b>
Inspection . . . . .	<b>75</b>	Steering Lock . . . . .	<b>31</b>
		Steering Lock Key . . . . .	<b>31</b>
		Switch . . . . .	<b>30</b>

Instruments		Scheduled Maintenance	62
Clock	27	Seat	40
Instrument Panel Layout	25	Side Covers	39
Odometer/Trip Meter	26	Specifications	109
Speedometer	26	Dimensions	109, 111
Tachometer	27	Electrical Equipment	118, 119
Warning Lights	28	Emissions Control Equipment	113
<b>L</b>		Engine	110, 112
Left Handlebar Switches	33	Fluids & Lubricants	118, 119
Headlight Dimmer Switch	33	Frame	118, 119
Horn Button	33	Fuel	113
Pass Button	33	Fuel System	113
Turn Signal Switch	33	Ignition	113
<b>O</b>		Lubrication	110, 112
Owner's Handbook	42	Performance	109, 111
<b>P</b>		Tightening Torques	118, 119
Parking	51	Tires	117
Parts Identification		Transmission	114, 115
Bonneville & Bonneville T100	14	Stand	41
Thruxton	16	Steering/Wheel Bearings	
Parts Identification - Scrambler	18	Wheel Bearings Inspection	85
<b>R</b>		Storage	107
Right Handlebar Switches	32	Preparation after Storage	107
Engine Stop Switch	32	Preparation for Storage	107
Starter Button	32	Suspension	
<b>S</b>		Front Fork Inspection	85
Safe Operation	43	Front Suspension Adjustment	86
Safety First	5	Rear Suspension Adjustment	87
Fuel & Exhaust Fumes	6	Suggested Settings	87
Handlebars & Footrests	9	Suspension Setting	86
Helmet & Clothing	8	<b>T</b>	
Maintenance/Equipment	11	Tail Light	
Parking	10	Bulb Replacement	101
Parts & Accessories	10	Throttle	
Riding	7	Adjustment	71
The Motorcycle	5	Inspection	70
Wobble/Weave	8	Throttle Grip	70
		Throttle Grip	70
		Tires	88
		Minimum Recommended Tread Depth	90

---

Tire Inflation Pressures . . . . .	90
Tire Pressures. . . . .	116, 117
Tire Replacement. . . . .	91
Tire Wear. . . . .	90
Turn Signal Lights . . . . .	101
Bulb Replacement . . . . .	101

## **V**

Vehicle Identification Number (V.I.N.) . . . .	21
--	----

## **W**

Warning Labels. . . . .	2
Warning Lights	
High Beam. . . . .	28
Low Oil Pressure . . . . .	28
Neutral. . . . .	28
Turn Signals. . . . .	28
Warnings. . . . .	1
Information . . . . .	3
Maintenance . . . . .	2
Owner's Handbook. . . . .	3
Warning Label Location . . . . .	12
Warning Lights . . . . .	28
Warnings, Cautions & Notes. . . . .	1