

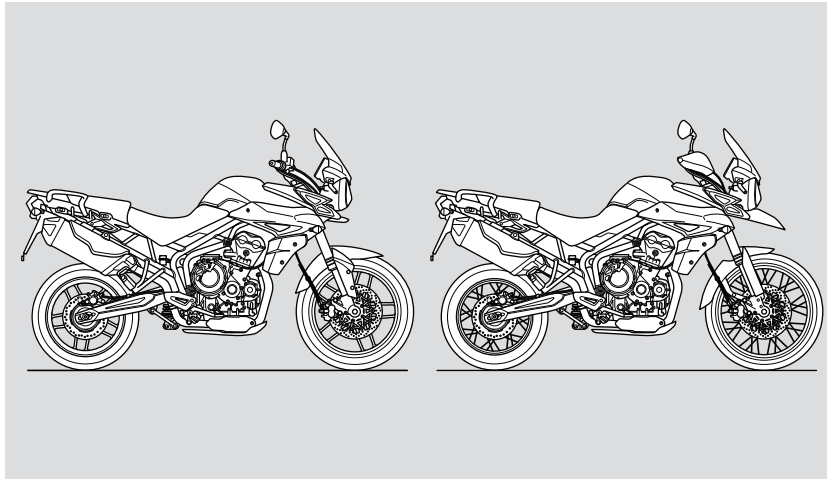

FOREWORD

This handbook contains information on the Triumph Tiger 800 and Tiger 800XC motorcycles. Always store this Owner's Handbook with the motorcycle and refer to it for information whenever necessary.



Warnings, Cautions and Notes

Throughout this Owner's Handbook particularly important information is presented in the following form:

 Warning
This warning symbol identifies special instructions or procedures, which if not correctly followed could result in personal injury, or loss of life.

 Caution
This caution symbol identifies special instructions or procedures, which, if not strictly observed, could result in damage to, or destruction of, equipment.

Note:

- **This note symbol indicates points of particular interest for more efficient and convenient operation.**

Foreword

Warning Labels

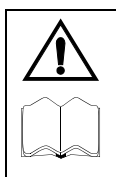

At certain areas of the motorcycle, the symbol (left) can be seen. The symbol means 'CAUTION: REFER TO THE HANDBOOK' and will be followed by a pictorial representation of the subject concerned.

Never attempt to ride the motorcycle or make any adjustments without reference to the relevant instructions contained in this handbook.

See page 12 for the location of all labels bearing this symbol. Where necessary, this symbol will also appear on the pages containing the relevant information.

Maintenance

To ensure a long, safe and trouble free life for your motorcycle, maintenance should only be carried out by an authorised Triumph dealer. Only an authorised Triumph dealer will have the necessary knowledge, equipment and skills to maintain your Triumph motorcycle correctly.

To locate your nearest Triumph dealer, visit the Triumph web site at www.triumph.co.uk or telephone the authorised distributor in your country. Their address is given in the service record book that accompanies this handbook.

Off-road Use

The Tiger 800XC is designed for on-road and light off-road use.

The Tiger 800 is designed for on-road use only.

Noise Control System

Tampering with the Noise Control System is Prohibited.

Owners are warned that the law may prohibit:

- The removal or rendering inoperative by any person other than for purposes of maintenance, repair or replacement, of any device or element of design incorporated into any new vehicle for the purpose of noise control prior to its sale or delivery to the ultimate purchaser or while it is in use and,
- the use of the vehicle after such device or element of design has been removed or rendered inoperative by any person.

Tyres

With reference to the Pneumatic Tyres and Tubes for Automotive Vehicles (Quality Control) Order, 2009, Cl. No. 3 (c), it is declared by M/s. Triumph Motorcycles Ltd. that the tyres fitted on this motorcycle meet the requirements of IS 15627: 2005 and comply with the requirements under Central Motor Vehicle Rules (CMVR), 1989.

Foreword

Immobiliser and Tyre Pressure Monitoring System

This device complies with part 15 of the FCC Rules.

Operation is subject to the following two conditions:

- This device may not cause harmful interference.
- This device must accept any interference received, including interference that may cause undesired operation.

Changes or modifications to the device could void the user's authority to operate the equipment.

Owner's Handbook

Thank you for choosing a Triumph motorcycle. This motorcycle is the product of Triumph's use of proven engineering, exhaustive testing, and continuous striving for superior reliability, safety and performance.

Please read this Owner's Handbook before riding in order to become thoroughly familiar with the correct operation of your motorcycle's controls, its features, capabilities and limitations.

This handbook includes safe riding tips, but does not contain all the techniques and skills necessary to ride a motorcycle safely.

Triumph strongly recommends that all riders undertake the necessary training to ensure safe operation of this motorcycle.

This handbook is also available from your local dealer in:

- Brazilian
- Dutch
- French
- German
- Italian
- Japanese
- Spanish
- Swedish.

Foreword

Warning

This Owner's Handbook, and all other instructions that are supplied with your motorcycle, should be considered a permanent part of your motorcycle and should remain with it even if your motorcycle is subsequently sold.

All riders must read this Owner's Handbook and all other instructions which are supplied with your motorcycle, before riding, in order to become thoroughly familiar with the correct operation of your motorcycle's controls, its features, capabilities and limitations. Do not lend your motorcycle to others as riding when not familiar with your motorcycle's controls, features, capabilities and limitations can lead to an accident.

Talk to Triumph

Our relationship with you does not end with the purchase of your Triumph. Your feedback on the buying and ownership experience is very important in helping us develop our products and services for you. Please help us by ensuring your dealership has your Email address and registers this with us. You will then receive an online customer satisfaction survey invitation to your Email address where you can give us this feedback.

Your Triumph Team.

Information

The information contained in this publication is based on the latest information available at the time of printing. Triumph reserves the right to make changes at any time without prior notice, or obligation.

Not to be reproduced wholly or in part without the written permission of Triumph Motorcycles Limited.

© Copyright 07.2013 Triumph Motorcycles Limited, Hinckley, Leicestershire, England.

Publication part number 3856669 issue 1.

Foreword

Table of Contents

This handbook contains a number of different sections. The table of contents below will help you find the beginning of each section where, in the case of the major sections, a further table of contents will help you find the specific subject required.

Foreword	1
Warning Labels	12
Parts Identification	14
Serial Numbers	19
General Information	21
How to Ride the Motorcycle	55
Accessories, Loading and Passengers	67
Maintenance and Adjustment	71
Storage	121
Specifications	123

Foreword - Safety First

FOREWORD - SAFETY FIRST

The Motorcycle

 **Warning**

The Tiger 800XC is designed for light off-road use. Extreme off-road use could lead to loss of motorcycle control and an accident.

 **Warning**

The Tiger 800 is designed for on-road use only. It is not suitable for off-road use. Off-road operation could lead to loss of control of the motorcycle resulting in an accident causing injury or loss of life.

 **Warning**

This motorcycle is not designed to tow a trailer or be fitted with a sidecar. Fitting a sidecar and/or a trailer may result in loss of control and an accident.

 **Warning**

This motorcycle is designed for use as a two-wheeled vehicle capable of carrying a rider on his/her own, or a rider and one passenger.

The total weight of the rider, and any passenger, accessories and luggage must not exceed the maximum load limit of:

Tiger 800 - 225 kg (496 lb)

Tiger 800XC - 223 kg (492 lb).

 **Warning**

This motorcycle is fitted with a catalytic converter below the engine, which along with the exhaust system reaches very high temperature during engine operation. Flammable materials such as grass, hay/straw, leaves, clothing and luggage etc. could ignite if allowed to come into contact with any part of the exhaust system and catalytic converter; always ensure flammable materials are not allowed to contact the exhaust system or catalytic converter.

Foreword - Safety First

Fuel and Exhaust Fumes

Warning

PETROL IS HIGHLY FLAMMABLE:

Always turn off the engine when refuelling. Do not refuel or open the fuel filler cap while smoking or in the vicinity of any open (naked) flame.

Take care not to spill any petrol on the engine, exhaust pipes or silencers when refuelling.

If petrol is swallowed, inhaled or allowed to get into the eyes, seek immediate medical attention.

Spillage on the skin should be immediately washed off with soap and water and clothing contaminated with petrol should immediately be removed.

Burns and other serious skin conditions may result from contact with petrol.

Warning

Never start your engine or let it run for any length of time in a closed area. The exhaust fumes are poisonous and may cause loss of consciousness and death within a short time. Always operate your motorcycle in the open-air or in an area with adequate ventilation.

Helmet and Clothing

Warning

When riding the motorcycle, both rider and passenger must always wear a motorcycle helmet, boots, eye protection, gloves, trousers (close fitting around the knee and ankle) and a brightly coloured jacket. Brightly coloured clothing will considerably increase a rider's (or passenger's) visibility to other operators of road vehicles. Although full protection is not possible, wearing correct protective clothing can reduce the risk of injury when riding.

Warning

A helmet is one of the most important pieces of riding gear as it offers protection against head injuries. You and your passenger's helmet should be carefully chosen and should fit you or your passenger's head comfortably and securely. A brightly coloured helmet will increase a rider's (or passenger's) visibility to other operators of road vehicles.

An open face helmet offers some protection in an accident though a full face helmet will offer more.

Always wear a visor or approved goggles to help vision and to protect your eyes.



Foreword - Safety First

Parking

Warning

Always turn off the engine and remove the ignition key before leaving the motorcycle unattended. By removing the key, the risk of use of the motorcycle by unauthorised or untrained persons is reduced.

When parking the motorcycle, always remember the following:

Engage first gear to help prevent the motorcycle from rolling off the stand.

The engine and exhaust system will be hot after riding. DO NOT park where pedestrians, animals and/or children are likely to touch the motorcycle.

Do not park on soft ground or on a steeply inclined surface. Parking under these conditions may cause the motorcycle to fall over.

For further details, please refer to the 'How to Ride the Motorcycle' section of this Owner's Handbook.

Parts and Accessories

Warning

Owners should be aware that the only approved parts, accessories and conversions for any Triumph motorcycle are those which carry official Triumph approval and are fitted to the motorcycle by an authorised dealer.

In particular, it is extremely hazardous to fit or replace parts or accessories whose fitting requires the dismantling of, or addition to, either the electrical or fuel systems and any such modification could cause a safety hazard.

The fitting of any non-approved parts, accessories or conversions may adversely affect the handling, stability or other aspect of the motorcycle operation that may result in an accident causing injury or death.

Triumph does not accept any liability whatsoever for defects caused by the fitting of non-approved parts, accessories or conversions or the fitting of any approved parts, accessories or conversions by non-approved personnel.

Foreword - Safety First

Maintenance/Equipment

Warning

Consult your authorised Triumph dealer whenever there is doubt as to the correct or safe operation of this Triumph motorcycle.

Remember that continued operation of an incorrectly performing motorcycle may aggravate a fault and may also compromise safety.

Warning

Ensure all equipment that is required by law is installed and functioning correctly. The removal or alteration of the motorcycle's lights, silencers, emission or noise control systems can violate the law. Incorrect or improper modification may adversely affect the handling, stability or other aspect of the motorcycle operation, which may result in an accident causing injury or death.

Warning

If the motorcycle is involved in an accident, collision or fall, it must be taken to an authorised Triumph dealer for inspection and repair. Any accident can cause damage to the motorcycle that, if not correctly repaired, may cause a second accident that may result in injury or death.

Riding

Warning

Never ride the motorcycle when fatigued or under the influence of alcohol or other drugs.

Riding when under the influence of alcohol or other drugs is illegal.

Riding when fatigued or under the influence of alcohol or other drugs reduces the rider's ability to maintain control of motorcycle and may lead to loss of control and an accident.

Warning

All riders must be licenced to operate the motorcycle. Operation of the motorcycle without a licence is illegal and could lead to prosecution.

Operation of the motorcycle without formal training in the correct riding techniques that are necessary to become licenced is dangerous and may lead to loss of motorcycle control and an accident.

Warning

Always ride defensively and wear the protective equipment mentioned elsewhere in this foreword. Remember, in an accident, a motorcycle does not give the same impact protection as a car.

Foreword - Safety First

Warning

This Triumph motorcycle should be operated within the legal speed limits for the particular road travelled. Operating a motorcycle at high speeds can be potentially dangerous since the time available to react to given traffic situations is greatly reduced as road speed increases. Always reduce speed in potentially hazardous driving conditions such as bad weather or heavy traffic.

Warning

Continually observe and react to changes in road surface, traffic and wind conditions. All two-wheeled vehicles are subject to external forces which may cause an accident. These forces include but are not limited to:

- Wind draft from passing vehicles
- Potholes, uneven or damaged road surfaces
- Bad weather
- Rider error.

Always operate the motorcycle at moderate speed and away from heavy traffic until you have become thoroughly familiar with its handling and operating characteristics. Never exceed the legal speed limit.

Handlebars and Footrests

Warning

Banking to an unsafe angle may cause instability, loss of motorcycle control and an accident.

Warning

The rider must maintain control of the vehicle by keeping hands on the handlebars at all times.

The handling and stability of a motorcycle will be adversely affected if the rider removes his hands from the handlebars, resulting in loss of motorcycle control and an accident.

Warning

The rider and passenger must always use the footrests provided, during operation of the vehicle.

By using the footrests, both rider and passenger will reduce the risk of inadvertent contact with any motorcycle components and will also reduce the risk of injury from entrapment of clothing.

Foreword - Safety First

Warning

The bank angle indicators must not be used as a guide to how far the motorcycle may be safely banked. This depends on many various conditions including, but not limited to, road surface, tyre condition and weather.

Banking to an unsafe angle may cause instability, loss of motorcycle control and an accident causing injury or death.

Bank Angle Indicators

Warning

When banking and the bank angle indicator, attached to the rider's footrest, makes contact with the ground, the motorcycle is nearing its bank angle limit. A further increase of the banking angle is unsafe.

Banking to an unsafe angle may cause instability, loss of motorcycle control and an accident causing injury or death.

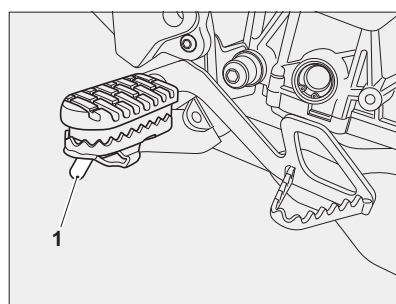

1. Bank angle indicator
(Tiger 800 shown)

Warning Labels

WARNING LABELS

The labels detailed on this and the following pages draw your attention to important safety information in this handbook. Before riding, ensure that all riders have understood and complied with all the information to which these labels relate.

Warning Label Locations - Tiger 800 and Tiger 800XC

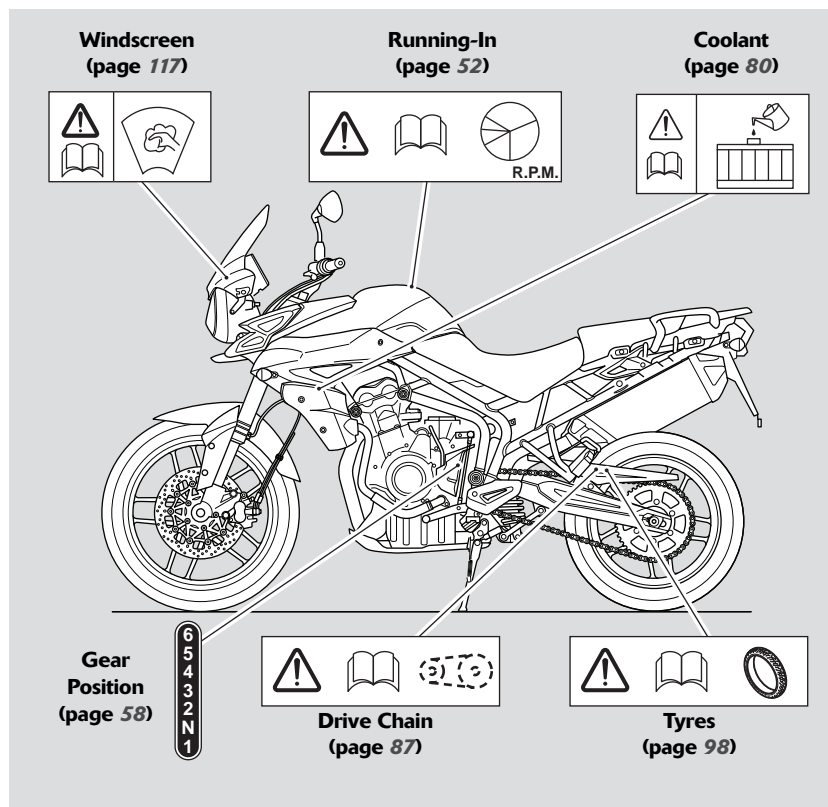

Warning Labels

Warning Label Locations - Tiger 800 and Tiger 800XC (continued)

Caution

All warning labels and decals, with the exception of the Running-in label, are fitted to the motorcycle using a strong adhesive. In some cases, labels are installed prior to an application of paint lacquer. Therefore, any attempt to remove the warning labels will cause damage to the paintwork or bodywork.

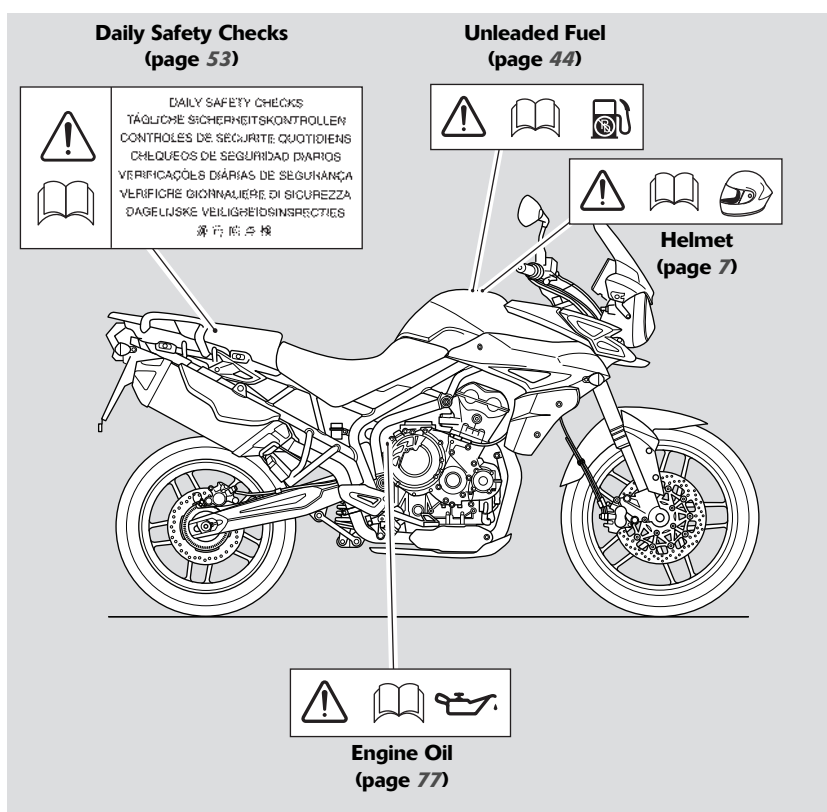

Parts Identification

PARTS IDENTIFICATION

Tiger 800

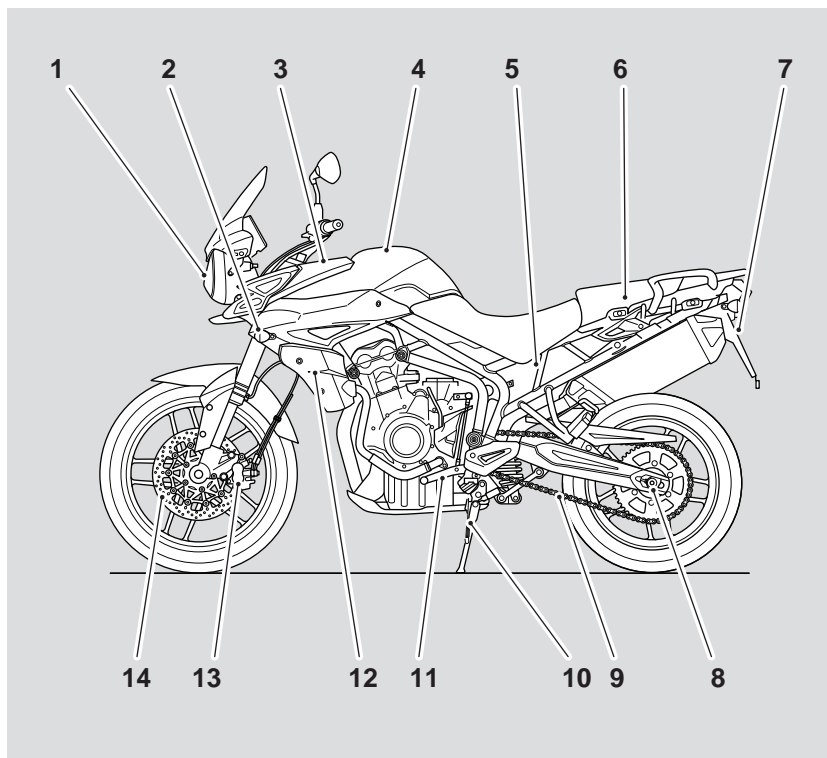

- | | |
|---|-----------------------------------|
| 1. Headlight | 8. Rear wheel adjuster |
| 2. Front indicator | 9. Drive chain |
| 3. Electrical accessory socket | 10. Side stand |
| 4. Fuel tank and fuel filler cap | 11. Gear-change pedal |
| 5. Battery and fuse boxes | 12. Radiator/Coolant pressure cap |
| 6. Tool kit/Accessory U-lock storage location | 13. Front brake caliper |
| 7. Seat lock | 14. Front brake disc |

Parts Identification

Tiger 800 (continued)

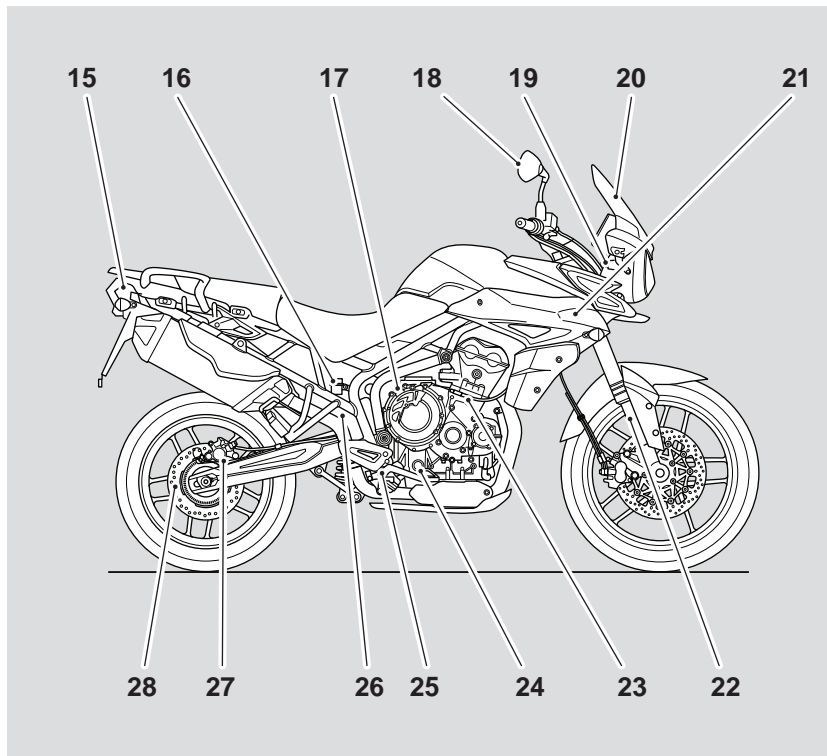

- | | |
|--------------------------------|--|
| 15. Rear light | 23. Clutch cable |
| 16. Rear brake fluid reservoir | 24. Engine oil level sight glass |
| 17. Oil filler cap | 25. Rear brake pedal |
| 18. Mirror | 26. Rear suspension spring pre-load adjuster |
| 19. Headlight adjuster | 27. Rear brake caliper |
| 20. Screen | 28. Rear brake disc |
| 21. Coolant expansion tank | |
| 22. Front fork | |

Parts Identification

Tiger 800XC

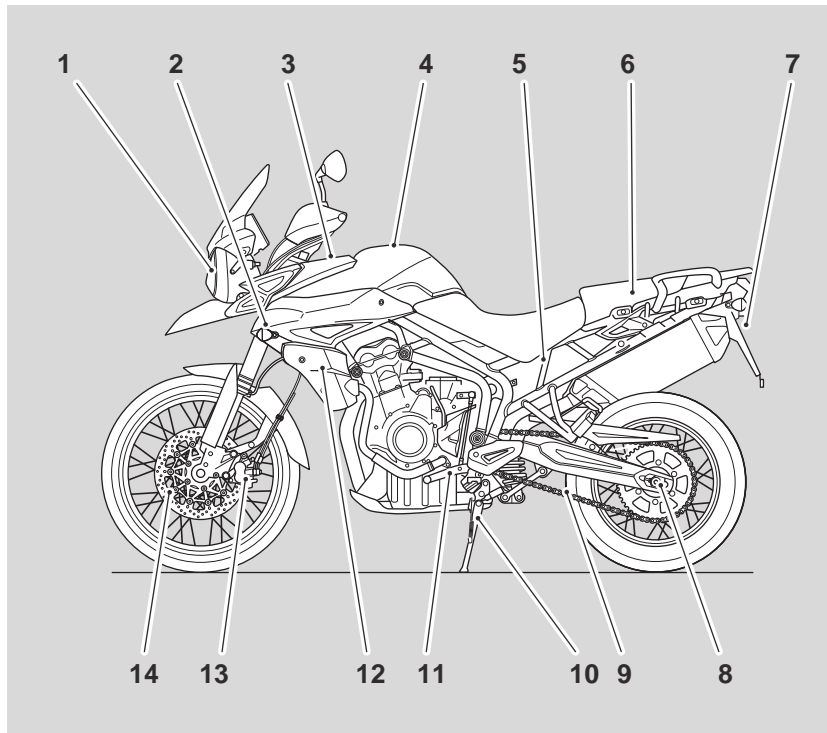

- | | |
|---|-----------------------------------|
| 1. Headlight | 8. Rear wheel adjuster |
| 2. Front indicator | 9. Drive chain |
| 3. Electrical accessory socket | 10. Side stand |
| 4. Fuel tank and fuel filler cap | 11. Gear-change pedal |
| 5. Battery and fuse boxes | 12. Radiator/Coolant pressure cap |
| 6. Tool kit/Accessory U-lock storage location | 13. Front brake caliper |
| 7. Seat lock | 14. Front brake disc |

Parts Identification

Tiger 800XC (continued)

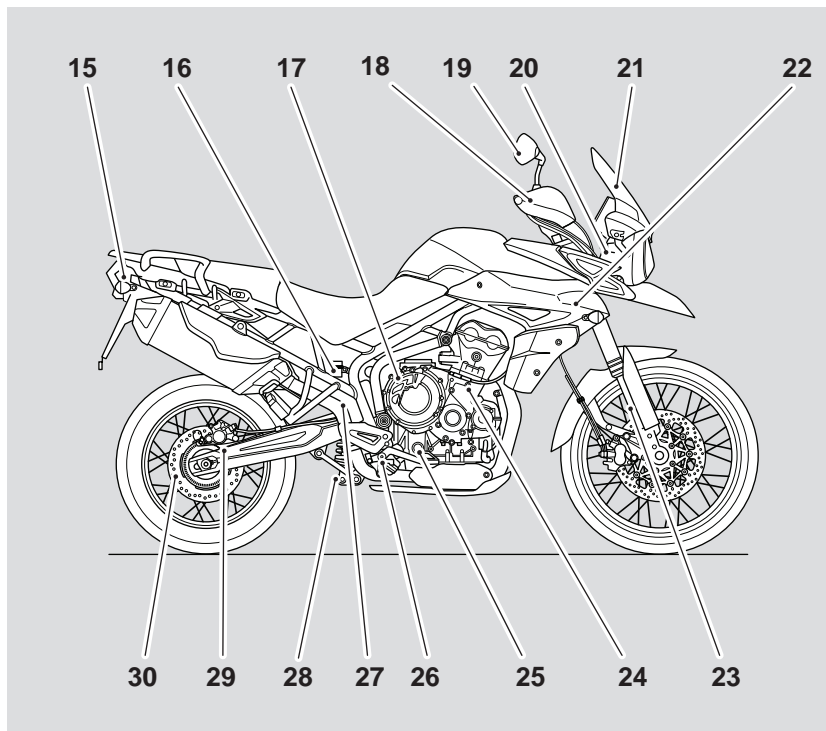

- | | |
|--------------------------------|--|
| 15. Rear light | 24. Clutch cable |
| 16. Rear brake fluid reservoir | 25. Engine oil level sight glass |
| 17. Oil filler cap | 26. Rear brake pedal |
| 18. Handguards | 27. Rear suspension pre-load adjuster |
| 19. Mirror | 28. Rear suspension rebound damping adjuster |
| 20. Headlight adjuster | 29. Rear brake caliper |
| 21. Screen | 30. Rear brake disc |
| 22. Coolant expansion tank | |
| 23. Front fork | |

Parts Identification

All Models (Tiger 800 shown)

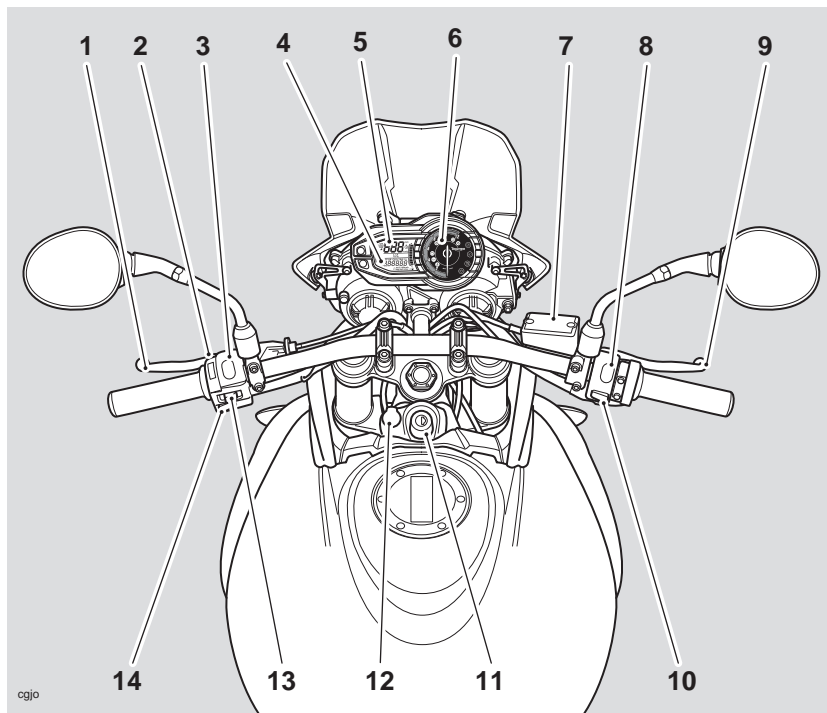

1. Clutch lever
2. Passing button
3. Headlight dip switch
4. Trip computer display
5. Speedometer
6. Tachometer
7. Front brake fluid reservoir

8. Engine stop switch
9. Front brake lever
10. Starter button
11. Ignition switch
12. Electrical accessory socket
13. Direction indicator switch
14. Horn button

SERIAL NUMBERS

Vehicle Identification Number (VIN)

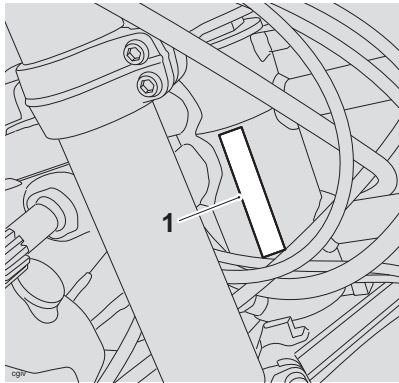

1. VIN number (Tiger 800 shown)

The Vehicle Identification Number (VIN) is stamped into the steering head area of the frame. It is also displayed on a plate, riveted to the frame, on the left hand side of the steering head.

Record the vehicle identification number in the space provided below.

Engine Serial Number

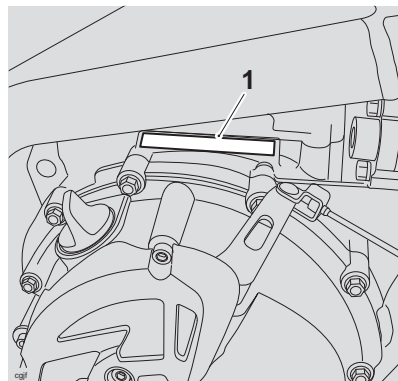

1. Engine serial number (Tiger 800 shown)

The engine serial number is stamped on the engine crankcase, immediately above the clutch cover.

Record the engine serial number in the space provided below.

Serial Numbers

This page intentionally left blank

GENERAL INFORMATION

Table of Contents

Instrument Panel Layout	23
Speedometer and Odometer	24
Tachometer	24
Trip Computer	24
Odometer/Trip Meter	25
Trip Meter	25
Trip Meter Reset	26
Odometer	26
Clock Adjustment	26
Changing Units (Imperial, US or Metric)	27
ABS Disable (models with ABS only)	29
Service Interval Indicator	29
Fuel Gauge	30
Tyre Pressure Monitoring System (TPMS)	30
Function	30
Tyre Pressure Sensor Serial Number	31
System Display	31
Sensor Batteries	32
Tyre Pressures	32
Replacement Tyres	33
Warning Lights	33
Direction Indicators	33
High Beam	33
Low Fuel	33
Neutral	33
Low Oil Pressure Warning Light	33
High Coolant Temperature Warning Light	34
Engine Management System Malfunction Indicator Light	34
Alarm/Immobiliser Indicator Light	35
Tyre Pressure Warning Light	36

General Information

Ignition Key	37
Ignition Switch/Steering Lock	38
Ignition Switch Positions	38
Brake Lever Adjuster	39
Right Handlebar Switches	40
Engine Stop Switch	40
Starter Button	41
Left Handlebar Switches	41
Headlight Dip Switch	41
Direction Indicator Switch	42
Horn Button	42
Pass Button	42
Handlebar Adjustment	42
Fuel Requirement/Refuelling	44
Fuel Grade	44
Fuel Tank Cap	45
Filling the Fuel Tank	45
Tool Kit and Handbook	46
Stand	46
Side Stand	46
Seats	47
Seat Care	47
Rear Seat	48
Rider's Seat	49
Rider's Seat Height Adjustment	49
Helmet Hook	50
Triumph Accessory D-lock Storage	51
Electrical Accessory Socket	52
Running-In	52
Safe Operation	53
Daily Safety Checks	53

General Information

Instrument Panel Layout

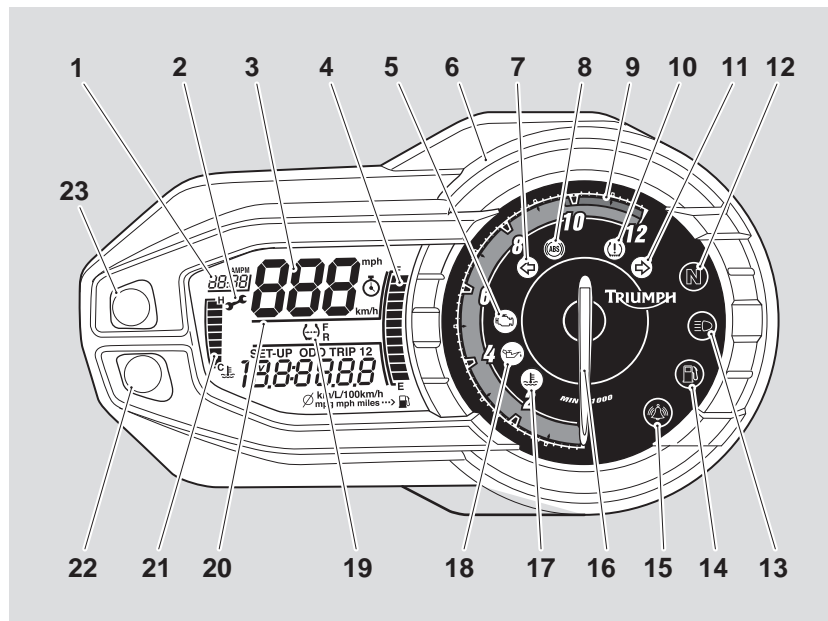

- | | |
|---|---|
| 1. Clock | 13. High beam indicator light |
| 2. Service interval indicator | 14. Low fuel level indicator light |
| 3. Speedometer | 15. Alarm/immobiliser status indicator light (alarm is an accessory fit) |
| 4. Fuel gauge | 16. Tachometer |
| 5. Engine management malfunction indicator light | 17. High coolant temperature warning light |
| 6. Instrument casing | 18. Low oil pressure warning light |
| 7. Left hand direction indicator light | 19. Tyre pressure display (if Tyre Pressure Monitoring System (TPMS) is fitted) (TPMS is not available on Tiger 800XC models) |
| 8. ABS warning light (ABS models only) | 20. Display screen |
| 9. Tachometer 'red zone' | 21. Coolant temperature display |
| 10. Tyre pressure warning light (if Tyre Pressure Monitoring System (TPMS) is fitted) (TPMS is not available on Tiger 800XC models) | 22. Button B |
| 11. Right hand direction indicator light | 23. Button A |
| 12. Neutral indicator light | |

General Information

Speedometer and Odometer

The digital speedometer indicates the road speed of the motorcycle. The read-out displays the motorcycle road speed in increments of one mile (or kilometre) per hour.

The electronic odometer and two trip meters are in the display screen. For details of the operation of the odometer and trip meters, please refer to the following pages.

Tachometer

The tachometer shows the engine speed in revolutions per minute - rpm (r/min). At the end of the tachometer range there is the 'red zone'. Engine rpm (r/min) in the red zone is above maximum recommended engine speed and is also above the range for best performance.

Caution

Never allow engine rpm to enter the 'red zone' as severe engine damage may result.

Trip Computer

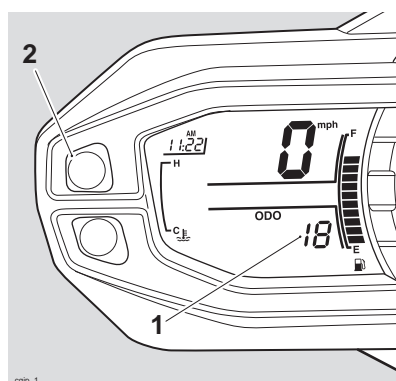

1. Display screen
2. Button A

To access the trip computer information press and release button 'A' until the desired display is visible. The display will scroll through in the following order:

- Trip Meter 1
- Trip Meter 2
- Tyre Pressure Monitoring system - if fitted (available as an accessory on Tiger 800 models only)
- Set up.

Note:

- **The tyre pressure monitoring system (TPMS) is an accessory which must be fitted by your authorised Triumph dealer. The TPMS display will then be activated by your authorised Triumph dealer (TPMS is not available on Tiger 800XC models).**

General Information

Odometer/Trip Meter

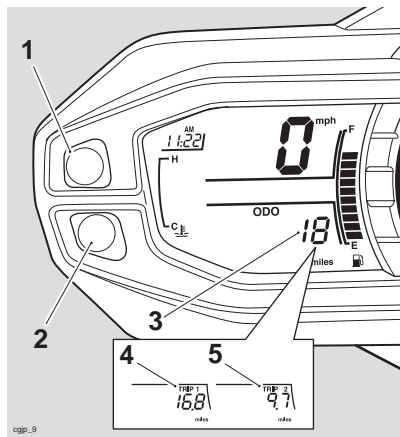

1. **Button A**
2. **Button B**
3. **Odometer/Trip meter display**
4. **Trip meter 1 display**
5. **Trip meter 2 display**

Trip Meter

Either trip meter shows the distance that the motorcycle has travelled, journey time, average fuel consumption, instantaneous fuel consumption and average speed, all since the trip meter on display was last reset to zero.

To access the trip meter information, turn the ignition to the ON position. Press and release button 'A' until the desired trip meter is visible in the display screen.

Press and release button 'B' until the desired display is visible. The display will scroll through in the following order:

- Journey distance
- Range to empty
- Journey time
- Average fuel consumption
- Instantaneous fuel consumption
- Average speed.

Each display provides the following information all calculated since the trip meter was last reset to zero:

Journey Distance

The total journey distance travelled.

Range to Empty

This is an indication of the probable distance that can be travelled on the remaining fuel in the tank.

Journey Time

The total time elapsed.

Average Fuel Consumption

An indication of the average fuel consumption. After being reset the display will show dashes until 0.1 miles/km has been covered.

Instantaneous Fuel Consumption

An indication of the fuel consumption at an instant in time.

Average Speed

The average speed is calculated from when the trip computer was last reset. After being reset the display will show dashes until 1 mile/km has been covered.

General Information

Warning

Do not attempt to switch between odometer and trip meter display modes or reset the trip meter with the motorcycle in motion as this may lead to loss of motorcycle control and an accident.

Trip Meter Reset

To reset either of the trip meters, select and display the trip meter to be zeroed then press button 'B' for 2 seconds. After 2 seconds, the trip meter on display will reset to zero.

Note:

- **When a trip meter is reset to zero, the journey time, average fuel consumption and average speed will also be set to zero for that trip meter.**

To exit the trip meter, press and release button 'A' until the desired display is visible.

Odometer

When the ignition is switched on, the odometer will be displayed for 3 seconds then the last selected trip meter will be shown.

The odometer shows the total distance that the motorcycle has travelled.

To access the odometer, with the motorcycle stationary and in neutral press and release button 'A' until set up is visible in the display screen then press button 'B'. Press and release button 'A' until odometer is visible.

To exit odometer, press and release button 'A' until rEturN is visible then press button 'B'. Trip 1 will be visible in the display screen.

Clock Adjustment

Warning

Do not attempt to adjust the clock with the motorcycle in motion as this may lead to loss of motorcycle control and an accident.

To reset the clock; with the motorcycle stationary and in neutral turn the ignition to the ON position. Press and release button 'A' until set up is visible in the display screen. Press button 'B' and t-SEt will be visible.

Press button 'B' again and either 24 Hr or 12 Hr clock will be shown. Press button 'A' to select the desired clock display and then press button 'B'. The hour display will start to flash and the word Hour is visible in the display screen.

To reset the hour display, ensure that the hour display is still flashing and the word Hour is visible. Press button 'A' to change the setting. Each individual button press will change the setting by one digit. If the button is held, the display will continuously scroll through in single digit increments.

When the correct hour display is shown, press button 'B'. The minutes display will begin to flash and the word Min is visible in the display screen. The minutes display is adjusted in the same way as for the hours.

General Information

Once both hours and minutes are correctly set, press button 'B' to confirm and t-SEt will be visible in the display screen. Press and release button 'A' until rEtturn is visible then press button 'B'. Trip 1 will be visible in the display screen.

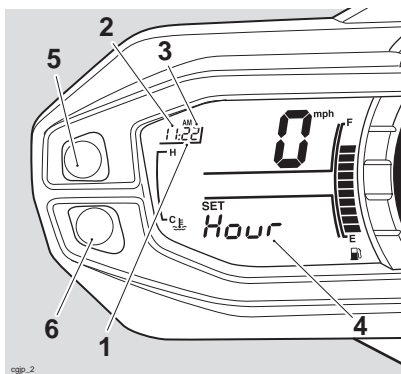

1. **Clock display**
2. **Hours read-out**
3. **Minutes read-out**
4. **Display screen (Hour selected for adjustment)**
5. **Button A**
6. **Button B**

Changing Units (Imperial, US or Metric)

Units has four selectable display modes as described below:

- mpg - Imperial gallons
- mpg US - US gallons
- L/100 km - Metric
- km/L - Metric.

Each display provides the following information:

mpg (Imperial gallons)

The speedometer and odometer will read in miles. The fuel consumption will be measured in imperial gallons.

mpg US (US gallons)

The speedometer and odometer will read in miles. The fuel consumption will be measured in US gallons.

L/100 km (Metric)

The speedometer and odometer will read in kilometres. The fuel consumption will be measured in litres of fuel per 100 km.

km/L (Metric)

The speedometer and odometer will read in kilometres. The fuel consumption will be measured in kilometers per litre of fuel.

Warning

Do not attempt to change the units display with the motorcycle in motion as this may lead to loss of motorcycle control and an accident.

General Information

To access the units display; with the motorcycle stationary and in neutral turn the ignition to the ON position.

Press and release button 'A' until set up is visible in the display screen then press button 'B'.

Press and release button 'A' until UnitS is visible then press button 'B'.

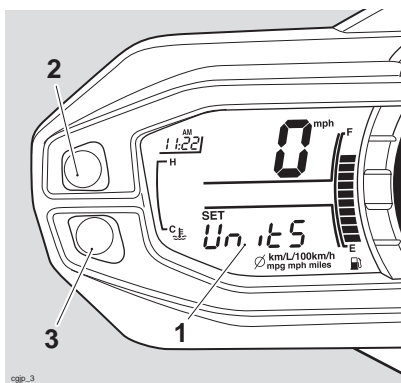

1. Display screen
2. Button A
3. Button B

Press and release button 'A' until the desired display is visible. The display will scroll through in the following order:

- mpg - Imperial gallons
- mpg US - US gallons
- L/100 km - Metric
- km/L - Metric.

Models without TPMS: Press button 'B' and do not touch buttons 'A' or 'B' again until UnitS is visible in the display screen. When UnitS is visible in the display screen, press and release button 'A' until rEturN is visible then press button 'B'. Trip 1 will be visible in the display screen.

Models with TPMS: Press button 'B' and do not touch buttons 'A' or 'B' again until PSI or bAr is displayed. Press and release button 'A' until the desired tyre pressure units are visible. Press button 'B' and wait until UnitS is displayed, then press button 'A' and when rEturN is displayed press button B. Trip 1 will be visible in the display screen.

General Information

ABS Disable (models with ABS only)

It is possible to temporarily disable the ABS system. The ABS system cannot be permanently disabled, it will be enabled when the ignition is turned off and then on again.

Warning

If the ABS is disabled, the brake system will function as a non-ABS braking system. In this situation braking too hard will cause the wheels to lock, and may result in loss of control and an accident.

To Disable the ABS

To access the ABS Disable function, turn the ignition to the ON position.

Press and release button 'A' until set up is visible in the display screen then press button 'B'.

Press and release button 'A' until ABS is visible.

Pressing button 'B' will disable the ABS system; the message ABS OFF will be displayed for 2 seconds, and the ABS warning light will be illuminated.

To Enable the ABS

To enable the ABS system again, turn the ignition off and on.

Service Interval Indicator

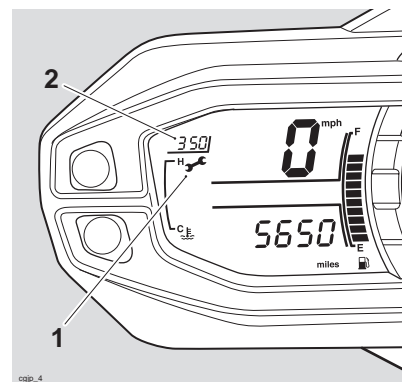

1. Service indicator
2. Remaining distance

When the ignition is switched on and the distance to the next service is 500 miles (800 km) or less, the service symbol will be displayed for 3 seconds and the clock will show the distance remaining before the next service.

When the remaining distance is 0 miles (0 km) the service symbol will remain on until the service has been carried out and the system has been reset by your authorised Triumph dealer. If the service is overdue, the distance will be displayed as a negative number.

General Information

Fuel Gauge

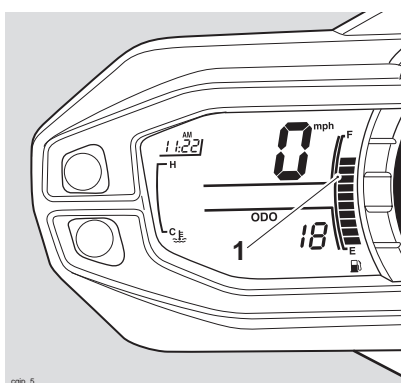

1. Fuel gauge

The fuel gauge indicates the amount of fuel in the tank.

With the ignition switched on, the number of bars shown in the display indicates the level of fuel.

When the fuel tank is full all 12 bars are displayed and when empty, no bars are displayed. Other gauge markings indicate intermediate fuel levels between full and empty.

When 2 bars are displayed the low fuel warning light will illuminate. This indicates there are approximately 4.5 litres of fuel remaining in the tank and you should refuel at the earliest opportunity. If a trip meter display is visible, the range to empty display can be selected by pressing and releasing button 'B' until it is visible.

After refuelling, the fuel gauge and range to empty information will be updated only while riding the motorcycle. Depending on the riding style, updating could take up to five minutes.

Tyre Pressure Monitoring System (TPMS)

Note:

- TPMS is an accessory option on Tiger 800 models only. It is not available on Tiger 800XC models.



Warning

The daily check of tyre pressures must not be excluded because of the fitment of the TPMS. Check the tyre pressure when the tyres are cold and using an accurate tyre pressure gauge (see page 100).

Use of the TPMS system to set inflation pressures may lead to incorrect tyre pressures leading to loss of motorcycle control and an accident.

Function

Tyre pressure sensors are fitted to the front and rear wheels. These sensors measure the air pressure inside the tyre and transmit pressure data to the instruments. These sensors will not transmit the data until the motorcycle is travelling at a speed greater than 12 mph (20 km). Two dashes will be visible in the display area until the tyre pressure signal is received.

General Information

The tyre pressure monitoring system (TPMS) is an accessory fitted item and must be fitted by your authorised Triumph dealer. The TPMS display on the instruments will only be activated when the system has been fitted.

An adhesive label will be fitted to the wheel rim to indicate the position of the tyre pressure sensor which is near the valve.

Tyre Pressure Sensor Serial Number

The serial number for the tyre pressure sensor is printed on a label attached to the sensor. This number may be required by the dealer for service or diagnostics.

When the tyre pressure monitoring system is being fitted to the motorcycle, ensure that the dealer records the serial numbers of the front and rear tyre pressure sensors in the spaces provided below.

Front Tyre Pressure Sensor

Rear Tyre Pressure Sensor

System Display

Warning

Do not attempt to switch between front and rear tyre display modes with the motorcycle in motion as this may lead to loss of motorcycle control and an accident

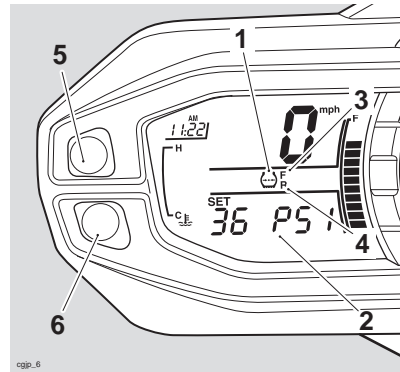

1. TPMS symbol
2. Tyre pressure display
3. Front tyre, identified
4. Rear tyre, identified
5. Button A
6. Button B

To access the tyre pressure display, turn the ignition to the ON position.

Press and release button 'A' until psi or bAr is visible in the display screen.

Press and release button 'B' to select the front or rear tyre pressure.

General Information

When the tyre pressure monitoring system has been selected, — psi or bAr will be visible in the display screen until the motorcycle is travelling at a speed greater than 12 mph (20 km) and the tyre pressure signal is received.

To exit the tyre pressure display, press and release button 'A' to the desired display.

Sensor Batteries

When the battery voltage in a pressure sensor is low, LO bAr will be displayed and the TPMS symbol will indicate which wheel sensor has the low battery voltage. If the batteries are completely flat, only dashes will be visible in the display screen, the red TPMS warning light will be on and the TPMS symbol will flash continuously. Contact your authorised Triumph dealer to have the sensor replaced and the new serial number recorded in the spaces provided on page 31.

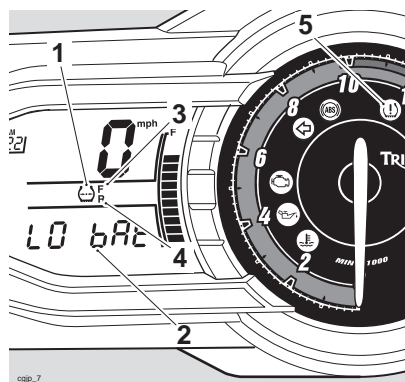

1. TPMS symbol
2. Display screen
3. Front tyre, identified
4. Rear tyre, identified
5. TPMS warning light

With the ignition switch turned to the ON position, if the TPMS symbol flashes for 10 seconds and then remains on there is a fault with the TPMS system. Contact your authorised Triumph dealer to have the fault rectified.

Tyre Pressures

The tyre pressures shown on your instrument panel indicate the actual tyre pressure at the time of selecting the display. This may differ from the inflation pressure set when the tyres are cold because tyres become warmer during riding, causing the air in the tyre to expand and the inflation pressure to increase. The cold inflation pressures specified by Triumph take account of this.

Owners must only adjust tyre pressures when the tyres are cold using an accurate tyre pressure gauge (see page 100), and must not use the tyre pressure display on the instruments.

Warning

The tyre pressure monitoring system is not to be used as a tyre pressure gauge when adjusting the tyre pressures. For correct tyre pressures, always check the tyre pressures when the tyres are cold and using an accurate tyre pressure gauge (see page 100).

Use of the TPMS system to set inflation pressures may lead to incorrect tyre pressures leading to loss of motorcycle control and an accident.

General Information

Replacement Tyres

When replacing tyres, always have an authorised Triumph dealer fit your tyres and ensure they are aware that tyre pressure sensors are fitted to the wheels (see page 102).

Warning Lights

Direction Indicators



When the indicator switch is pushed to the left or right, the turn indicator light will flash on and off at the same speed as the turn indicators.

High Beam



When the ignition is switched on and the headlight dip switch is set to 'high beam', the high beam warning light will illuminate.

Low Fuel



The low fuel indicator will illuminate when there are approximately 4.5 litres of fuel remaining in the tank.

Neutral



The neutral warning light indicates when the transmission is in neutral (no gear selected). The warning light will illuminate when the transmission is in neutral with the ignition switch in the ON position.

Low Oil Pressure Warning Light



With the engine running, if the engine oil pressure becomes dangerously low, the low oil pressure warning light in the tachometer will illuminate.

General Information

Caution

Stop the engine immediately if the low oil pressure warning light illuminates. Do not restart the engine until the fault has been rectified.

Severe engine damage will result from running the engine when the low oil pressure warning light is illuminated.

The low oil pressure warning light in the tachometer will illuminate if the ignition is switched on without running the engine.

High Coolant Temperature Warning Light



With the engine running, if the engine coolant temperature becomes dangerously high, the high coolant temperature warning light in the tachometer will illuminate.

Caution

Stop the engine immediately if the high coolant temperature warning light illuminates. Do not restart the engine until the fault has been rectified.

Severe engine damage will result from running the engine when the high coolant temperature warning light is illuminated.

The high coolant temperature warning light in the tachometer will illuminate if the ignition is switched on without running the engine.

Engine Management System Malfunction Indicator Light



The malfunction indicator light for the engine management system illuminates briefly when the ignition is switched on (to indicate that it is working), but should not become illuminated when the engine is running.

If the malfunction indicator light becomes illuminated when the engine is running, this indicates that a fault has occurred in one or more of the systems controlled by the engine management system. In such circumstances, the engine management system will switch to 'limp-home' mode so that the journey may be completed, if the fault is not so severe that the engine will not run.

Warning

Reduce speed and do not continue to ride for longer than is necessary with the malfunction indicator light illuminated. The fault may adversely affect engine performance, exhaust emissions and fuel consumption. Reduced engine performance could cause a dangerous riding condition, leading to loss of control and an accident. Contact an authorised Triumph dealer as soon as possible to have the fault checked and rectified.

General Information

Note:

- **If the malfunction indicator light flashes when the ignition is switched on, contact an authorised Triumph dealer as soon as possible to have the situation rectified. In these circumstances the engine will not start.**

Alarm/Immobiliser Indicator Light



This Triumph model is fitted with an engine immobiliser which is activated when the ignition switch is turned to the OFF position. If the motorcycle is fitted with a genuine Triumph accessory alarm, the immobiliser will operate as normal but the alarm/immobiliser light will operate as described below.

With Alarm Fitted

The alarm/immobiliser light will only illuminate when the conditions described in the genuine triumph accessory alarm instructions are met.

Without Alarm Fitted

When the ignition switch turned to the OFF position, the alarm/immobiliser light will flash on and off for 24 hours to show that the engine immobiliser is on. When the ignition switch is turned to the ON position the immobiliser and the indicator light will be off. If the indicator light remains on it indicates that the immobiliser has a malfunction that requires investigation. Contact an authorised Triumph dealer as soon as possible to have the fault checked and rectified.

ABS (Anti-Lock Brake System) Indicator light (Only on models fitted with ABS)



When the ignition switch is turned to the ON position, it is normal that the ABS warning light will flash on and off. The light will continue to flash after engine start-up until the motorcycle first reaches a speed exceeding 6 mph (10 km/h) when it will go off.

Unless the ABS system is disabled (see page 29), or there is a fault, it should not illuminate again until the engine is restarted.

If the indicator light becomes illuminated at any other time while riding it indicates that the ABS has a malfunction that requires investigation.

Warning

If the ABS is not functioning, the brake system will continue to function as a non ABS braking system. Do not continue to ride for longer than is necessary with the indicator light illuminated. Contact an authorised Triumph dealer as soon as possible to have the fault checked and rectified. In this situation braking too hard will cause the wheels to lock resulting in loss of control and an accident.

See also Braking on page 59.

General Information

Tyre Pressure Warning Light

Note:

- **TPMS is an accessory option on Tiger 800 models only. It is not available on Tiger 800XC models.**



The tyre pressure warning light works in conjunction with the tyre pressure monitoring system (see page 30).

The warning light will only illuminate when the front or rear tyre pressure is below the recommended pressure. It will not illuminate if the tyre is over inflated.

When the warning light is illuminated, the TPMS symbol indicating which is the deflated tyre and its pressure will automatically be visible in the display area.

The tyre pressure at which the warning light illuminates is temperature compensated to 20°C but the numeric pressure display associated with it is not (see page 100). Even if the numeric display seems at or close to the standard tyre pressure when the warning light is on, a low tyre pressure is indicated and a puncture is the most likely cause.

Warning

Stop the motorcycle if the tyre pressure warning light illuminates. Do not ride the motorcycle until the tyres have been checked and the tyre pressures are at their recommended pressure when cold.

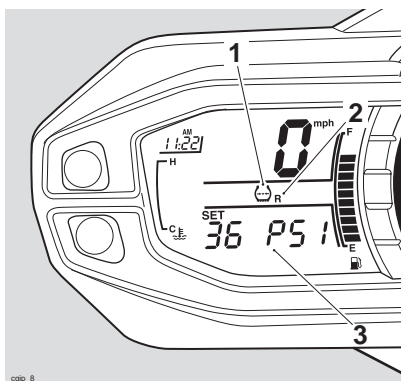

1. **TPMS symbol**
2. **Rear tyre, identified**
3. **Tyre pressure**

General Information

Ignition Key

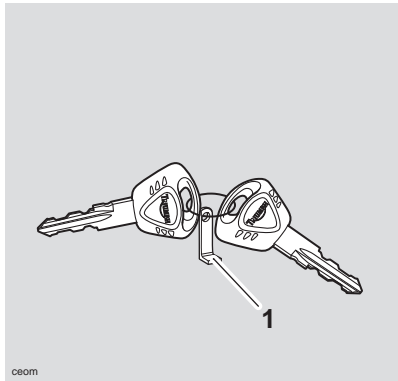

1. Key number tag

In addition to operating the steering lock/ignition switch, the ignition key is required to operate the seat lock and fuel tank cap.

When the motorcycle is delivered from the factory, two keys are supplied together with a small tag bearing the key number. Make a note of the key number and store the spare key and key number tag in a safe place away from the motorcycle.

A transponder is fitted within the key to turn off the engine immobiliser. To ensure the immobiliser functions correctly, always have only one of the ignition keys near the ignition switch. Having two ignition keys near the switch may interrupt the signal between the transponder and the engine immobiliser. In this situation the engine immobiliser will remain active until one of the ignition keys is removed.

Always get replacement keys from your authorised Triumph dealer. Replacement keys must be 'paired' with the motorcycle's immobiliser by your authorised Triumph dealer.

Caution

Do not store the spare key with the motorcycle as this will reduce all aspects of security.

General Information

Ignition Switch/Steering Lock

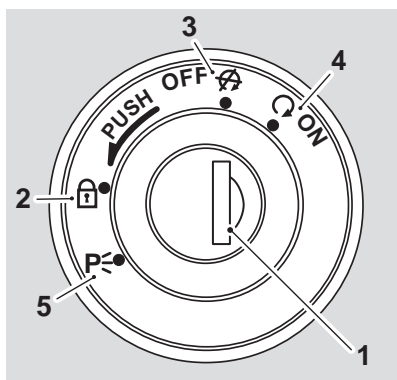

1. Ignition switch/steering lock
2. LOCK position
3. OFF position
4. ON position
5. PARK position

Ignition Switch Positions

This is a four position, key operated switch. The key can be removed from the switch only when it is in the OFF, LOCK or P (PARK) position.

TO LOCK: Turn the handlebar to the left until the arrow on the upper yoke aligns with the ignition key.

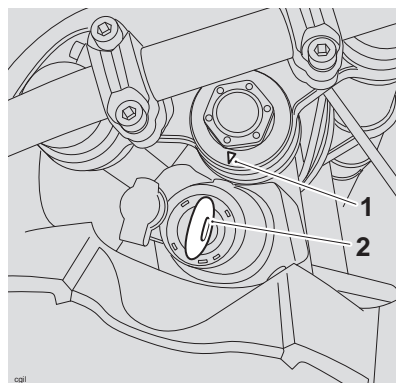

1. Arrow on upper yoke
2. Ignition key

Turn the key to the OFF position, push and fully release the key, then rotate it to the LOCK position.

PARKING: Turn the key from the LOCK position to the P position. The steering will remain locked, and the position lights will be switched on.

Note:

- **Do not leave the steering lock in the P position for long periods of time as this will cause the battery to discharge.**

General Information

Warning

For reasons of security and safety, always move the ignition switch to the OFF position and remove the key when leaving the motorcycle unattended.

Any unauthorised use of the motorcycle may cause injury to the rider, other road users and pedestrians and may also cause damage to the motorcycle.

Warning

With the key in the LOCK or P position the steering will become locked.

Never turn the key to the LOCK or P positions while the motorcycle is moving as this will cause the steering to lock. Locked steering will cause loss of motorcycle control and an accident.

Brake Lever Adjuster

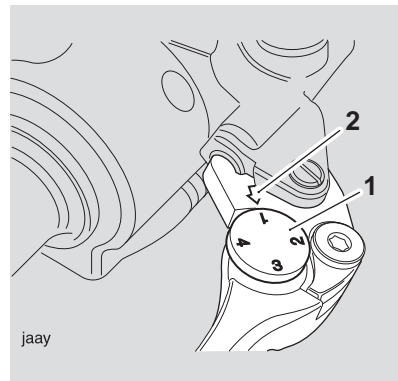

1. Adjuster wheel
2. Triangular mark

An adjuster is fitted to the front brake lever. The adjuster allows the distance from the handlebar to the lever to be changed to one of four positions, to suit the span of the operator's hands.

To adjust the lever, push the lever forward and turn the adjuster wheel to align one of the numbered positions with the triangular mark on the lever holder.

The distance from the handlebar grip to the released lever is shortest when set to number four, and longest when set to number one.

General Information

Warning

Do not attempt to adjust the lever with the motorcycle in motion as this may lead to loss of motorcycle control and an accident.

After adjusting the lever, operate the motorcycle in an area free from traffic to gain familiarity with the new lever setting. Do not loan your motorcycle to anyone as they may change the lever setting from the one you are familiar with causing loss of control or an accident.

Right Handlebar Switches

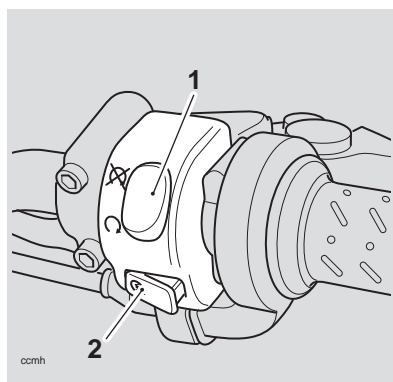

1. Engine stop switch
2. Starter button

Engine Stop Switch

In addition to the ignition switch being turned to the ON position, the engine stop switch must be in the RUN position for the motorcycle to operate.

The engine stop switch is for emergency use. If an emergency arises which requires the engine to be stopped, move the engine stop switch to the STOP position.

Note:

- **Although the engine stop switch stops the engine, it does not turn off all the electrical circuits and may cause difficulty in restarting the engine due to a discharged battery. Ordinarily, only the ignition switch should be used to stop the engine.**

General Information

Caution

Do not leave the ignition switch in the ON position unless the engine is running as this may cause damage to electrical components and will discharge the battery.

Starter Button

The starter button operates the electric starter. For the starter to operate, the clutch lever must be pulled to the handlebar.

Note:

- **Even if the clutch lever is pulled to the handlebar, the starter will not operate if the side stand is down and a gear is engaged.**

With the engine running, the starter button functions as the lap timer 'trigger' button. Momentarily pressing the starter button will start the lap timer recording the next lap.

Left Handlebar Switches

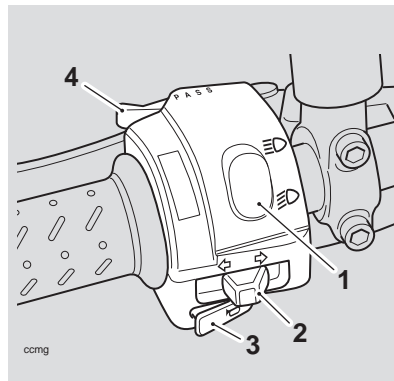

1. **Headlight dip switch**
2. **Direction indicator switch**
3. **Horn button**
4. **Pass button**

Headlight Dip Switch

High or low beam can be selected with the headlight dip switch. To select high beam, push the switch forward. To select low beam, push the switch rearwards. When the high beam is turned on, the high beam indicator light will illuminate.

Note:

- **A lighting on/off switch is not fitted to this model. The headlight, rear light and licence plate light all function automatically when the ignition is turned to the ON position.**

General Information

Direction Indicator Switch

When the indicator switch is pushed to the left or right and released, the corresponding direction indicators will flash on and off. To turn off the indicators, push and release the switch.

Horn Button

When the horn button is pushed, with the ignition switch turned to the ON position, the horn will sound.

Pass Button

When the pass button is pressed, the headlight main beam will be switched on. It will remain on as long as the button is held in and will turn off as soon as the button is released.

Handlebar Adjustment

The handlebars are adjustable for reach by approximately 20 mm.

Warning

It is recommended to have handlebar adjustments carried out by a trained technician of an authorised Triumph dealer. Handlebar adjustments carried out by a technician who is not of an authorised Triumph dealer may affect the handling, stability or other aspects of the motorcycle's operation which may result in loss of motorcycle control and an accident.

Warning

Before starting work, ensure the motorcycle is stabilised and adequately supported. This will help prevent injury to the operator or damage to the motorcycle.

Note:

- **This procedure assumes the handlebars are in the standard position, as delivered from the factory. If the handlebars have already been adjusted as described below, the bolt positions will be reversed.**

General Information

To adjust the handlebars, loosen and remove the handlebar rear (8 mm threaded) clamp bolts, and then the front (10 mm threaded) clamp and riser bolts.

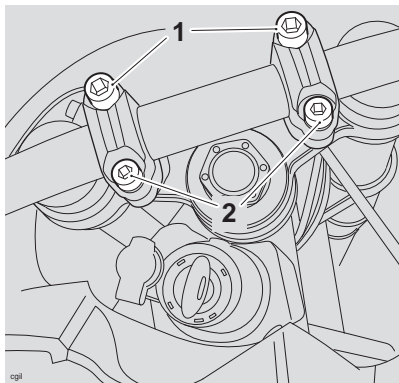

1. 10 mm fixings
2. 8 mm fixings

Lift the handlebars out of the handlebar risers and support with the aid of an assistant.

Rotate both risers through 180° and align the bolt holes.

Reposition the handlebars to the risers.

Refit the upper clamps, and secure with the two 10 mm threaded bolts in the rear bolt positions. Do not fully tighten the bolts at this stage.

Rotate the handlebar so that the etched centre (longer) marking on the handlebar aligns with the split line on the upper clamps/risers.

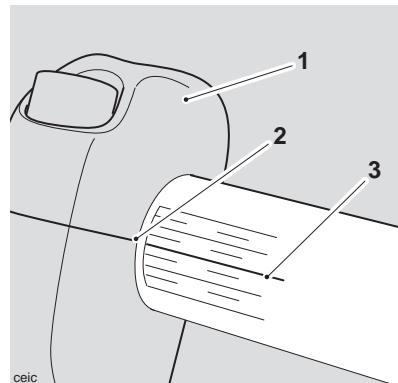

1. Upper clamp
2. Clamp split line
3. Centre marking

Tighten the 10 mm bolts to **35 Nm**.

Refit the 8 mm bolts to the front positions and tighten to **26 Nm**.

General Information

Fuel Requirement/Refuelling

Fuel Grade



Your Triumph engine is designed to use unleaded fuel and will give optimum performance if the correct grade of fuel is used. Tiger 800 and Tiger 800XC models can use unleaded fuel with an octane rating of 91 RON or higher.

Caution

The exhaust system is fitted with a catalytic converter to help reduce exhaust emission levels. The catalytic converter can be permanently damaged if the motorcycle is allowed to run out of fuel or if the fuel level is allowed to get very low. Always ensure you have adequate fuel for your journey.

Caution

The use of leaded fuel is illegal in most countries, states or territories. Use of leaded fuel will damage the catalytic converter.

Warning

To help reduce hazards associated with refuelling, always observe the following fuel safety instructions:

Petrol (fuel) is highly flammable and can be explosive under certain conditions. When refuelling, turn the ignition switch to the OFF position.

Do not smoke.

Do not use a mobile telephone.

Make sure the refuelling area is well ventilated and free from any source of flame or sparks. This includes any appliance with a pilot light.

Never fill the tank until the fuel level rises into the filler neck. Heat from sunlight or other sources may cause the fuel to expand and overflow creating a fire hazard.

After refuelling always check that the fuel filler cap is correctly closed and locked.

Because petrol (fuel) is highly flammable, any fuel leak or spillage, or any failure to observe the safety advice given above will lead to a fire hazard, which could cause damage to property, injury to persons or death.

General Information

Fuel Tank Cap

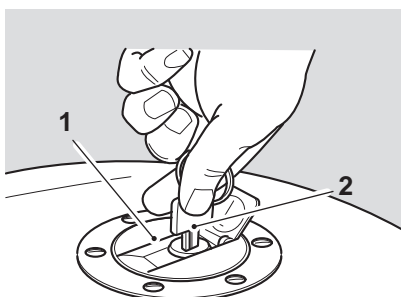

cbmm1

1. Fuel tank cap
2. Key

To open the fuel tank cap, lift up the flap covering the lock itself. Insert the key into the lock and turn the key clockwise.

To close and lock the cap, push the cap down into place with the key inserted, until the lock 'clicks' into place. Withdraw the key and close the key cover.

Caution

Closing the cap without the key inserted will damage the cap, tank and lock mechanism.

Filling the Fuel Tank

Avoid filling the tank in rainy or dusty conditions where airborne material can contaminate the fuel.

Caution

Contaminated fuel may cause damage to fuel system components.

Fill the fuel tank slowly to help prevent spillage. Do not fill the tank to a level above the bottom of the filler neck. This will ensure there is enough air space to allow for fuel expansion if the fuel inside the tank expands through absorption of heat from the engine or from direct sunlight.

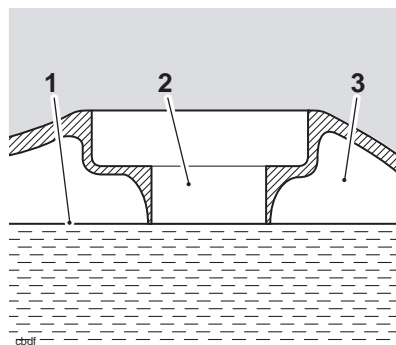

1. Maximum fuel level
2. Fuel filler neck
3. Air space

General Information

Warning

Overfilling the tank can lead to fuel spillage.

If fuel is spilled, thoroughly clean up the spillage immediately and dispose of the materials used safely.

Take care not to spill any fuel on the engine, exhaust pipes, tyres or any other part of the motorcycle.

Because fuel is highly flammable, any fuel leak or spillage, or any failure to observe the safety advice given above may lead to a fire hazard, which could cause damage to property and injury or death to persons.

Fuel spilled near to, or onto the tyres will reduce the tyre's ability to grip the road. This will result in a dangerous riding condition potentially causing loss of motorcycle control and an accident.

After refuelling always check that the fuel filler cap is correctly closed and locked.

Tool Kit and Handbook

The tool kit is located beneath the rear seat.

The handbook is located beneath the pillion's seat.

Stand

Side Stand

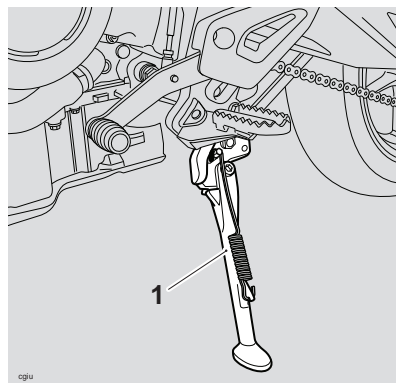

1. Side stand

The motorcycle is equipped with a side stand on which the motorcycle can be parked.

Warning

The motorcycle is fitted with an interlock system to prevent it from being ridden with the side stand in the down position.

Never attempt to ride with the side stand down or interfere with the interlock mechanism as this will cause a dangerous riding condition leading to loss of motorcycle control and an accident.

General Information

Note:

- **When using the side stand, always turn the handlebars fully to the left and leave the motorcycle in first gear.**

Whenever the side stand is used, before riding, always ensure that the side stand is fully up after first sitting on the motorcycle.

For instructions on safe parking, refer to the 'How to Ride the Motorcycle' section.

Seats

Seat Care

To prevent damage to the seat or seat cover, care must be taken not to drop or lean the seat against any surface which may damage the seat or seat cover.

See page 116 for seat cleaning information.

Caution

To prevent damage to the seat or seat cover, care must be taken not to drop the seat. Do not lean the seat against the motorcycle or any surface which may damage the seat or seat cover. Instead, place the seat, with the seat cover facing upwards, on a clean, flat surface which is covered with a soft cloth.

Do not place any item on the seat which may cause damage or staining to the seat cover.

General Information

Rear Seat

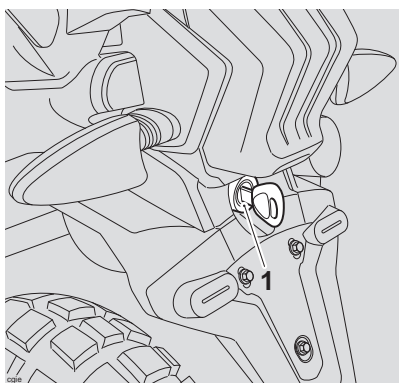

1. Seat lock

The seat lock is located on the rear mudguard, below the rear light unit. To remove the seat, insert the ignition key into the seat lock and turn it anti-clockwise while pressing down on the rear of the seat. This will release the seat from its lock and allow it to be slid rearwards for complete removal from the motorcycle.

To refit the seat, engage the seat's two brackets under the loops on the subframe and press down at the rear to engage in the seat lock.

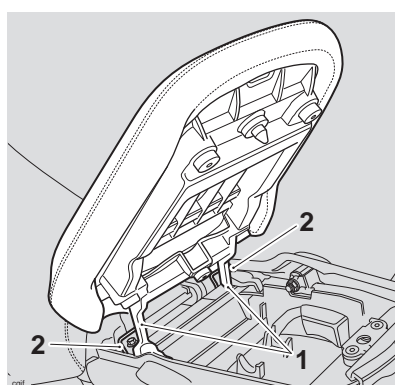

1. Rear seat brackets

2. Subframe loops

Warning

The rider's seat is only correctly retained and supported once the rear seat is correctly fitted. Never ride the motorcycle with the rear seat detached or removed, as the front seat will not be secure and may move.

A loose or detached seat could cause loss of motorcycle control and an accident.

General Information

Warning

To prevent detachment of the seat during riding, after fitting always grasp the seat and pull firmly upwards. If the seat is not correctly secured, it will detach from the lock. A loose or detached seat could cause loss of motorcycle control and an accident.

Rider's Seat

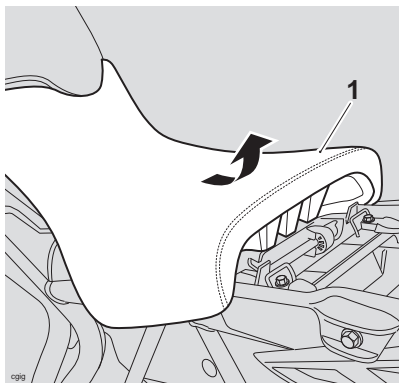

1. Rider's seat

To remove the rider's seat, remove the rear seat (see page 48).

Grasp the rider's seat on either side, and slide it rearwards and upwards for complete removal from the motorcycle.

To refit the seat, engage the seat's front rail into the bracket at the rear of the fuel tank and lower the rear rail in to the rear brackets. Push down firmly on the rear of the seat. Refit the rear seat (see page 48).

Warning

The rider's seat is only correctly retained and supported once the rear seat is correctly fitted. Never ride the motorcycle with the rear seat detached or removed, as the front seat will not be secure and may move.

A loose or detached seat could cause loss of motorcycle control and an accident.

Rider's Seat Height Adjustment

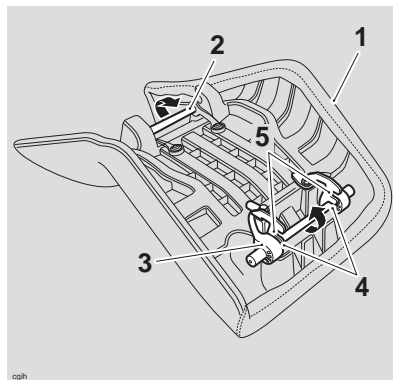

1. Rider's seat
2. Front seat height adjuster
3. Rear seat height adjuster
4. Low seat height position (rear shown)
5. High seat height position (rear shown)

The rider's seat is adjustable for height by approximately 25 mm.

To adjust the rider's seat:

Remove the rider's seat (see page 49).

General Information

Reposition both seat height adjusters to the higher or lower position as required. Ensure both adjuster rails are fully engaged in their brackets on the seat.

Refit the rider's seat (see page 49).

Warning

Always adjust both seat height adjusters. Adjusting only one height adjuster may prevent correct fitment of the seat.

Riding the motorcycle with an incorrectly fitted seat may cause loss of control or an accident.

Warning

After adjusting the seat, operate the motorcycle in an area free from traffic to gain familiarity with the new seat position. Riding the motorcycle with the seat in an unfamiliar position may cause loss of control or an accident.

Helmet Hook

A helmet can be secured to the motorcycle using the helmet hook located on the left hand side of the motorcycle, beneath the seat.

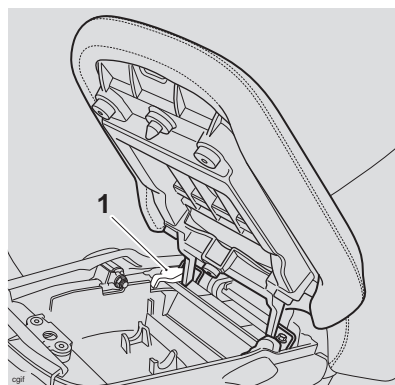

1. Helmet hook

General Information

To attach a helmet to the motorcycle, remove the seat and loop the helmet chin strap over the hook. Ensure the flat area above the hook is not obstructed by the helmet strap, as this will prevent the rear seat engaging correctly.

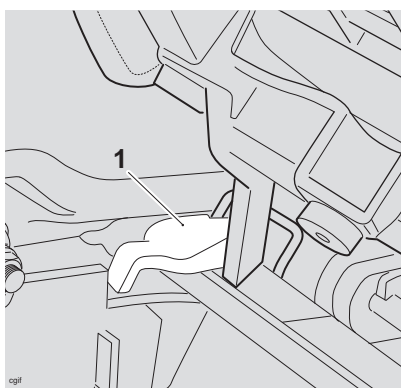

1. Helmet hook flat area

To secure the helmet, re-fit the seat and lock into position.

Warning

Never ride the motorcycle with helmet(s) secured to the helmet hook. Riding the motorcycle with helmet(s) secured to the helmet hook may cause the motorcycle to become unstable leading to loss of control and an accident.

Caution

Do not allow helmets to rest against a hot silencer. The helmet may be damaged.

Triumph Accessory D-lock Storage

Space is provided under the rear seat to store a Triumph accessory D-lock (available from your Triumph dealer).

Secure the lock as follows:

Release the strap securing the tool kit.

Position the U-section of the lock to the rear mudguard support features, ensuring the open end faces towards the rear of the motorcycle.

Secure the U-section using the tool kit strap as shown below.

Position the lock body to the tray in the rear mudguard.

Refit the rear seat to secure the lock body.

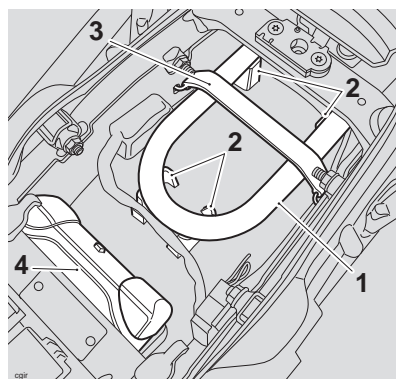

1. Lock U-section
2. Rear mudguard lock support features
3. Tool kit strap (tool kit shown removed for clarity)
4. Lock body

General Information

Electrical Accessory Socket

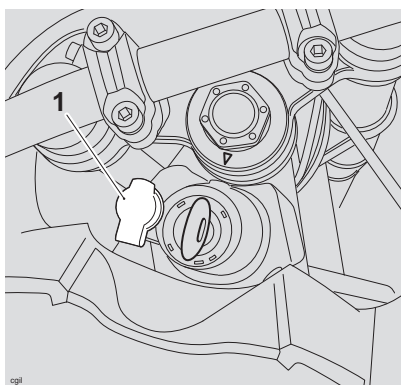

1. Electrical accessory socket

An electrical accessory socket is provided on the motorcycle, located next to the ignition switch.

The socket will provide a 12 Volt electrical supply. Refer to the label in the fuse box lid for fuse amperage (see page 109).

To protect the battery from excessive discharge while using fitted electrical accessories the combined total current which may be drawn through the standard (and auxiliary sockets if fitted) is 5 Amps.

A plug, suitable for use with the accessory socket, is available from your authorised Triumph dealer.

Running-In



Running-in is the name given to the process that occurs during the first hours of a new vehicle's operation.

In particular, internal friction in the engine will be higher when components are new. Later on, when continued operation of the engine has ensured that the components have 'bedded in', this internal friction will be greatly reduced.

A period of careful running-in will ensure lower exhaust emissions, and will optimise performance, fuel economy and longevity of the engine and other motorcycle components.

During the first 500 miles (800 kilometres):

- Do not use full throttle.
- Avoid high engine speeds at all times.
- Avoid riding at one constant engine speed, whether fast or slow, for a long period of time.
- Avoid aggressive starts, stops, and rapid accelerations, except in an emergency.
- Do not ride at speeds greater than 3/4 of maximum engine speed.

General Information

From 500 to 1,000 miles (800 to 1,500 kilometres):

- Engine speed can gradually be increased to the rev limit for short periods.

Both during and after running-in has been completed:

- Do not over-rev the engine when cold.
- Do not let the engine labour. Always downshift before the engine begins to 'struggle'.
- Do not ride with engine speeds unnecessarily high. Changing up a gear helps reduce fuel consumption, reduces noise and helps to protect the environment.

Safe Operation

Daily Safety Checks



Check the following items each day before you ride. The time required is minimal, and these checks will help ensure a safe, reliable ride.

If any irregularities are found during these checks, refer to the Maintenance and Adjustment section or see your authorised Triumph dealer for the action required to return the motorcycle to a safe operating condition.

Warning

Failure to perform these checks every day before you ride may result in serious motorcycle damage or an accident causing serious injury or death.

General Information

Check:

Fuel: Adequate supply in tank, no fuel leaks (page 44).

Engine Oil: Correct level on dipstick. Add correct specification oil as required. No leaks from the engine or oil cooler (page 77).

Drive Chain: Correct adjustment (page 87).

Tyres/Wheels: Correct inflation pressures (when cold). Tread depth/wear, tyre/wheel damage, punctures etc. (page 98).

Nuts, Bolts, Fasteners: Visually check that steering and suspension components, axles, and all controls are properly tightened or fastened. Inspect all areas for loose/damaged fixings.

Steering Action: Smooth but not loose from lock to lock. No binding of any of the control cables (page 94).

Brakes: Pull the brake lever and push the brake pedal to check for correct resistance. Investigate any lever/pedal where the travel is excessive before meeting resistance, or if either control feels spongy in operation (page 91).

Brake Pads: There should be more than 1.5 mm of friction material remaining on all the pads (page 92).

Brake Fluid Levels: No brake fluid leakage. Brake fluid levels must be between the MAX and MIN marks on both reservoirs (page 92).

Front Forks: Smooth action. No leaks from fork seals (page 96).

Throttle: Throttle grip free play 2 - 3 mm. Ensure that the throttle grip returns to the idle position without sticking (page 83).

Clutch: Smooth operation and correct cable free play (page 86).

Coolant: No coolant leakage. Check the coolant level in the expansion tank (when the engine is cold) (page 80).

Electrical Equipment: All lights and the horn function correctly (page 37).

Engine Stop: Stop switch turns the engine off (page 56).

Stands: Returns to the fully up position by spring tension. Return springs not weak or damaged (page 46).

How to Ride the Motorcycle

HOW TO RIDE THE MOTORCYCLE

Table of Contents

To Stop the Engine.....	56
To Start the Engine.....	56
Moving Off.....	58
Changing Gears.....	58
Braking.....	59
ABS (Anti-Lock Brake System) - (if fitted).....	61
Parking.....	62
Considerations for High-Speed Operation.....	63
General.....	64
Steering.....	64
Luggage.....	64
Brakes.....	64
Tyres.....	64
Fuel.....	64
Engine Oil.....	65
Coolant.....	65
Electrical Equipment.....	65
Miscellaneous.....	65

How to Ride the Motorcycle

To Stop the Engine

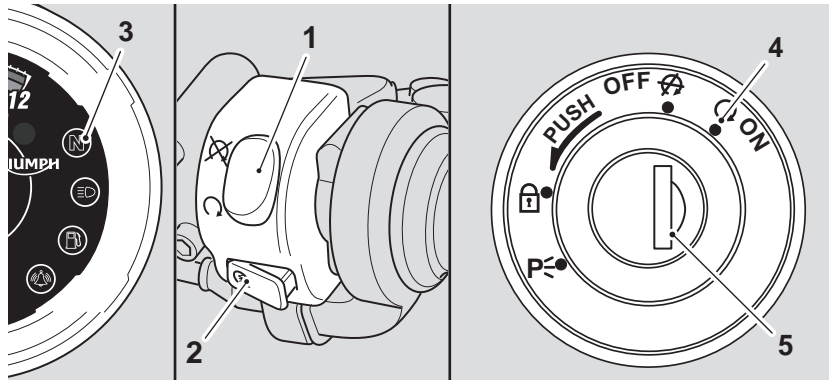

1. Engine stop switch
2. Starter button
3. Neutral indicator light
4. ON position
5. Ignition switch

Close the throttle completely.

Select neutral.

Turn the ignition switch off.

Select first gear.

Support the motorcycle on a firm, level surface with the side stand.

Lock the steering.

Caution

The engine should normally be stopped by turning the ignition switch to the OFF position. The engine stop switch is for emergency use only. Do not leave the ignition switched on with the engine stopped. Electrical damage may result.

To Start the Engine

Check that the engine stop switch is in the RUN position.

Ensure the transmission is in neutral.

Turn the ignition switch on.

Note:

- When the ignition is switched on, the tachometer needle will quickly sweep from zero to maximum and then return to zero. The instrument warning lights will illuminate and will then go off (except those which normally remain on until the engine starts - see 'Warning Lights' on page 33). It is not necessary to wait for the needle to return to zero before starting the engine.

How to Ride the Motorcycle

- **A transponder is fitted within the key to turn off the engine immobiliser. To ensure the immobiliser functions correctly, always have only one of the ignition keys near the ignition switch. Having two ignition keys near the switch may interrupt the signal between the transponder and the engine immobiliser. In this situation the engine immobiliser will remain active until one of the ignition keys is removed.**

Pull the clutch lever fully into the handlebar.

Leaving the throttle fully closed, push the starter button until the engine starts.

Warning

Never start the engine or run the engine in a confined area. Exhaust fumes are poisonous and can cause loss of consciousness and death within a short period of time. Always operate your motorcycle in the open-air or in an area with adequate ventilation.

Caution

Do not operate the starter continuously for more than 5 seconds as the starter motor will overheat and the battery will become discharged. Wait 15 seconds between each operation of the starter to allow for cooling and recovery of battery power.

Do not let the engine idle for long periods as this may lead to overheating which will cause damage to the engine.

Caution

The low oil pressure warning light should go out shortly after the engine starts.

If the low oil pressure warning light stays on after starting the engine, stop the engine immediately and investigate the cause. Running the engine with low oil pressure will cause severe engine damage.

- The motorcycle is equipped with starter lockout switches. The switches prevent the electric starter from operating when the transmission is not in neutral with the side stand down.
- If the side stand is extended whilst the engine is running, and the transmission is not in neutral then the engine will stop regardless of clutch position.

How to Ride the Motorcycle

Moving Off

Pull in the clutch lever and select first gear. Open the throttle a little and let out the clutch lever slowly. As the clutch starts to engage, open the throttle a little more, allowing enough engine speed to avoid stalling.

Changing Gears

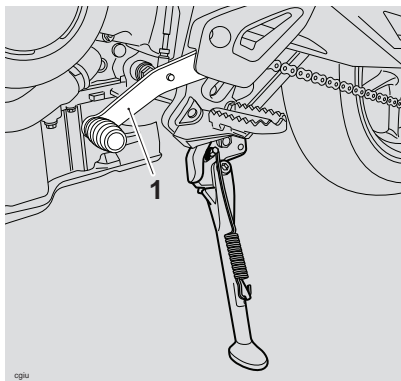

1. Gear-change pedal



Close the throttle while pulling in the clutch lever. Change into the next higher or lower gear. Open the throttle part way, while releasing the clutch lever. Always use the clutch when changing gear.

Warning

Take care to avoid opening the throttle too far or too fast in any of the lower gears as this can lead to the front wheel lifting from the ground (pulling a 'wheelie') and to the rear tyre breaking traction (wheel spin).

Always open the throttle cautiously, particularly if you are unfamiliar with the motorcycle, as a 'wheelie' or loss of traction will cause loss of motorcycle control and an accident.

Note:

- The gear change mechanism is the 'positive stop' type. This means that, for each movement of the gear change pedal, you can only select each gear, one after the other, in ascending or descending order.

Warning

Do not change to a lower gear at speeds that will cause excessive engine rpm (r/min). This can lock the rear wheel causing loss of control and an accident. Engine damage may also be caused. Changing down should be done such that low engine speeds will be ensured.

How to Ride the Motorcycle

Braking

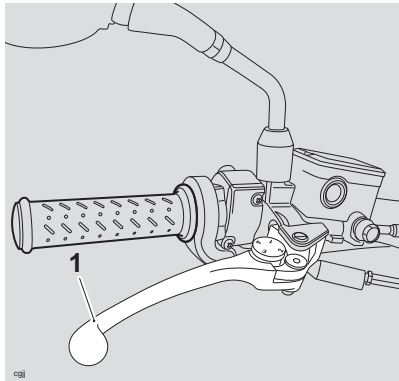

1. Front brake lever

Warning

WHEN BRAKING, OBSERVE THE FOLLOWING:

Close the throttle completely, leaving the clutch engaged to allow the engine to help slow down the motorcycle.

Change down one gear at a time such that the transmission is in first gear when the motorcycle comes to a complete stop.

When stopping, always apply both brakes at the same time. Normally the front brake should be applied a little more than the rear.

Change down or fully disengage the clutch as necessary to keep the engine from stalling.

Never lock the brakes, as this may cause loss of control of the motorcycle and an accident.

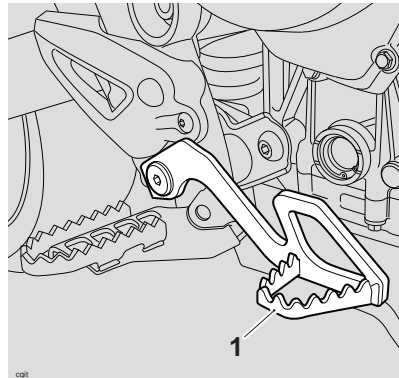

1. Rear brake pedal

How to Ride the Motorcycle

Warning

For emergency braking, disregard down changing, and concentrate on applying the front and rear brakes as hard as possible without skidding. Riders should practice emergency braking in a traffic-free area (see ABS warnings below/over).

Triumph strongly recommends that all riders take a course of instruction, which includes advice on safe brake operation. Incorrect brake technique could result in loss of control and an accident.

Warning

For your safety, always exercise extreme caution when braking (whether or not ABS is fitted), accelerating or turning as any incautious action can cause loss of control and an accident. Independent use of the front or rear brakes reduces overall braking performance. Extreme braking may cause either wheel to lock, reducing control of the motorcycle and causing an accident (see ABS warnings below).

When possible, reduce speed or brake before entering a turn as closing the throttle or braking in mid-turn may cause wheel slip leading to loss of control and an accident.

When riding in wet or rainy conditions, or on loose surfaces, the ability to manoeuvre and stop will be reduced. All of your actions should be smooth under these conditions. Sudden acceleration, braking or turning may cause loss of control and an accident.

Warning

When descending a long, steep gradient, use engine braking by down changing and use the brakes intermittently. Continuous brake application can overheat the brakes and reduce their effectiveness.

Riding with your foot on the brake pedal or your hands on the brake lever may actuate the brake light, giving a false indication to other road users. It may also overheat the brake, reducing braking effectiveness.

Do not coast with the engine switched off, and do not tow the motorcycle. The transmission is pressure-lubricated only when the engine is running. Inadequate lubrication may cause damage or seizure of the transmission, which can lead to sudden loss of motorcycle control and an accident.

Warning

When using the motorcycle on loose, wet, or muddy roads, braking effectiveness will be reduced by dust, mud or moisture collecting on the brakes. Always brake earlier in these conditions to ensure brake surfaces are cleaned by the braking action. Riding the motorcycle with brakes contaminated with dust, mud or moisture may cause loss of control and an accident.

How to Ride the Motorcycle

ABS (Anti-Lock Brake System) - (if fitted)

Warning

Where fitted, ABS prevents the wheels from locking, therefore maximising the effectiveness of the braking system in emergencies and when riding on slippery surfaces. The potentially shorter braking distances ABS allows under certain conditions are not a substitute for good riding practice.

Always ride within the legal speed limit.

Never ride without due care and attention and always reduce speed in consideration of weather, road and traffic conditions.

Take care when cornering. If the brakes are applied in a corner, ABS will not be able to counteract the weight and momentum of the motorcycle. This can result in loss of control and an accident.

Under some circumstances it is possible that a motorcycle equipped with ABS may require a longer stopping distance than an equivalent motorcycle without ABS.

ABS Warning Light



When the ignition switch is turned to the ON position, it is normal for the ABS warning light to flash on and off (see page 33). If the ABS warning light is constantly illuminated it indicates that the ABS function is not available because:

- The ABS has been disabled by the rider (see page 29)
- The ABS has a malfunction that requires investigation.

If the indicator light becomes illuminated while riding, it indicates that the ABS has a malfunction that requires investigation.

Note:

- **Normally, the rider will perceive ABS operation as a harder feel or a pulsation of the brake lever and pedal. As the ABS is not an integrated braking system and it does not control both the front and rear brake at the same time, this pulsation may be felt in the lever, the pedal or both.**
- **The ABS may be activated by sudden upward or downward changes in the road surface.**

How to Ride the Motorcycle

Warning

If the ABS is not functioning, the brake system will continue to function as a non-ABS braking system. Do not continue to ride for longer than is necessary with the indicator light illuminated. In the event of a fault, contact an authorised Triumph dealer as soon as possible to have the fault checked and rectified. In this situation, braking too hard will cause the wheels to lock resulting in loss of control and an accident.

Warning

The ABS warning light will illuminate when the rear wheel is driven at high speed for more than 30 seconds when the motorcycle is on a stand. This reaction is normal.

When the ignition is switched off and the motorcycle is re-started, the warning light will illuminate until the motorcycle reaches a speed exceeding 19 mph (30 km/h).

Warning

The ABS computer operates by comparing the relative speed of the front and rear wheels. Use of non-recommended tyres can affect wheel speed and cause the ABS function not to operate, potentially leading to loss of control and an accident in conditions where the ABS would normally function.

Parking

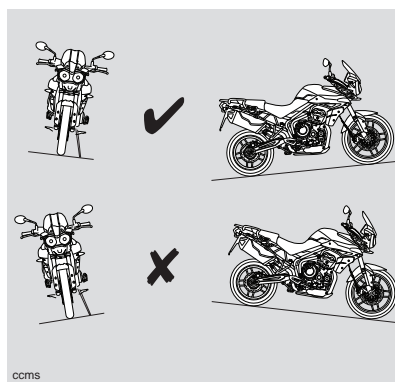

Select neutral and turn the ignition switch to the OFF position.

Lock the steering to help prevent theft.

Always park on a firm, level surface to prevent the motorcycle from falling. This is particularly important when parking off road.

When parking on a hill, always park facing uphill to prevent the motorcycle from rolling off the stand. Engage first gear to prevent the motorcycle from moving.

On a lateral (sideways) incline, always park such that the incline naturally pushes the motorcycle towards the sidestand.

Do not park on a lateral (sideways) incline of greater than 6° and never park facing downhill.

Note:

- **When parking near traffic at night, or when parking in a location where parking lights are required by law, leave the tail, licence plate and position lights on by turning the ignition switch to P (PARK).**

How to Ride the Motorcycle

Do not leave the switch in the P position for long periods of time as this will discharge the battery.

Warning

Do not park on a soft or on a steeply inclined surface. Parking under these conditions may cause the motorcycle to fall over causing damage to property and personal injury.

Warning

Petrol is extremely flammable and can be explosive under certain conditions. If parking inside a garage or other structure, be sure it is well ventilated and the motorcycle is not close to any source of flame or sparks. This includes any appliance with a pilot light.

Failure to follow the above advice may cause a fire resulting in damage to property or personal injury.

Warning

The engine and exhaust system will be hot after riding. DO NOT park where pedestrians and children are likely to touch the motorcycle.

Touching any part of the engine or exhaust system when hot may cause unprotected skin to become burnt.

Considerations for High-Speed Operation

Warning

This Triumph motorcycle should be operated within the legal speed limits for the particular road travelled. Operating a motorcycle at high speeds can be potentially dangerous since the time available to react to given traffic situations is greatly reduced as road speed increases. Always reduce speed in consideration of weather and traffic conditions.

Warning

Only operate this Triumph motorcycle at high speed in closed-course on-road competition or on closed-course racetracks. High-speed operation should only then be attempted by riders who have been instructed in the techniques necessary for high-speed riding and are familiar with the motorcycle's characteristics in all conditions.

High-speed operation in any other circumstances is dangerous and will lead to loss of motorcycle control and an accident.

How to Ride the Motorcycle

Warning

The handling characteristics of a motorcycle at high speed may vary from those you are familiar with at legal road speeds. Do not attempt high-speed operation unless you have received sufficient training and have the required skills as a serious accident may result from incorrect operation.

Warning

The items listed are extremely important and must never be neglected. A problem, which may not be noticed at normal operating speeds, may be greatly exaggerated at high speeds.

General

Ensure the motorcycle has been maintained according to the scheduled maintenance chart.

Steering

Check that the handlebar turns smoothly without excessive free play or tight spots. Ensure that the control cables do not restrict the steering in any way.

Luggage

Make certain that any luggage containers are closed, locked and securely fitted to the motorcycle.

Brakes

Check that the front and rear brakes are functioning properly.

Tyres

High-speed operation is hard on tyres, and tyres that are in good condition are crucial to riding safely. Examine their overall condition, inflate to the correct pressure (when the tyres are cold), and check the wheel balance. Securely fit the valve caps after checking tyre pressures. Observe the information given in the Maintenance and Specification sections on tyre checking and tyre safety.

Fuel

Have sufficient fuel for the increased fuel consumption that will result from high-speed operation.

Caution

The exhaust system is fitted with a catalytic converter to help reduce exhaust emission levels. The catalytic converter can be permanently damaged if the motorcycle is allowed to run out of fuel or if the fuel level is allowed to get very low. Always ensure you have adequate fuel for your journey.

How to Ride the Motorcycle

Engine Oil

Make certain that the engine oil level is correct. Ensure that the correct grade and type of oil is used when topping up.

Coolant

Check that the coolant level is at the upper level line in the expansion tank. (Always check the level with the engine cold.)

Electrical Equipment

Make certain that the headlight, rear/brake light, direction indicators, horn, etc. all work properly.

Miscellaneous

Visually check that all fixings are tight.

How to Ride the Motorcycle

This page intentionally left blank

Accessories, Loading and Passengers

ACCESSORIES, LOADING AND PASSENGERS

The addition of accessories and carriage of additional weight can affect the motorcycle's handling characteristics causing changes in stability and necessitating a reduction in speed. The following information has been prepared as a guide to the potential hazards of adding accessories to a motorcycle and carrying passengers and additional loads.

Adjust the headlight aim to compensate for additional loads, see page 111.

Warning

Incorrect loading may result in an unsafe riding condition leading to an accident.

Always ensure any loads carried are evenly distributed on both sides of the motorcycle. Ensure that the load is correctly secured such that it will not move around while the motorcycle is in motion.

Always check the load security regularly (though not while the motorcycle is in motion) and ensure that the load does not extend beyond the rear of the motorcycle.

Never exceed the maximum vehicle loading weight of:

Tiger 800 - 225 kg (496 lb)

Tiger 800XC - 223 kg (492 lb).

This maximum loading weight is made up from the combined weight of the rider, passenger, any accessories fitted and any load carried.

Warning

Do not install accessories or carry luggage that impairs the control of the motorcycle. Make sure that you have not adversely affected the visibility of any lighting component, road clearance, banking capability (i.e. lean angle), control operation, wheel travel, front fork movement, visibility in any direction, or any other aspect of the motorcycle's operation.

Warning

This motorcycle must not be operated above the legal road speed limit except in authorised closed-course conditions.

Warning

Only operate this Triumph motorcycle at high speed in closed-course on-road competition or on closed-course racetracks. High-speed operation should only then be attempted by riders who have been instructed in the techniques necessary for high-speed riding and are familiar with the motorcycle's characteristics in all conditions.

High-speed operation in any other circumstances is dangerous and will lead to loss of motorcycle control and an accident.

Accessories, Loading and Passengers

Warning

Your passenger should be instructed that he or she can cause loss of motorcycle control by making sudden movements or by adopting an incorrect seated position.

The rider should instruct the passenger as follows:

- It is important that the passenger sits still while the motorcycle is in motion and does not interfere with the operation of the motorcycle.
- To keep his or her feet on the passenger footrests and to firmly hold onto the seat strap or the rider's waist or hips.
- Advise the passenger to lean with the rider when travelling around corners and not to lean unless the rider does so.

Warning

Do not carry animals on your motorcycle. An animal could make sudden and unpredictable movements that could lead to loss of motorcycle control and an accident.

Warning

The handling and braking capabilities of a motorcycle will be affected by the presence of a passenger. The rider must make allowances for these changes when operating the motorcycle with a passenger and should not attempt such operation unless trained to do so and without becoming familiar and comfortable with the changes in motorcycle operating characteristics that this brings about.

Motorcycle operation without making allowances for the presence of a passenger could lead to loss of motorcycle control and an accident.

Warning

Never attempt to store any items between the frame and the fuel tank. This can restrict the steering and will cause loss of control leading to an accident.

Weight attached to the handlebar or front fork will increase the mass of the steering assembly and can result in loss of steering control leading to an accident.

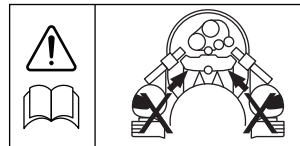

Accessories, Loading and Passengers

Warning

Do not carry a passenger unless he or she is tall enough to reach the footrests provided.

A passenger who is not tall enough to reach the footrests will be unable to sit securely on the motorcycle and may cause instability leading to loss of control and an accident.

Warning

Never ride an accessory equipped motorcycle, or a motorcycle carrying a payload of any kind, at speeds above 80 mph (130 km/h). In either/both of these conditions, speeds in excess of 80 mph (130 km/h) should not be attempted even where the legal speed limit permits this.

The presence of accessories and/or payload will cause changes in the stability and handling of the motorcycle.

Failure to allow for changes in motorcycle stability may lead to loss of control or an accident.

Remember that the 80 mph (130 km/h) absolute limit will be reduced by the fitting of non-approved accessories, incorrect loading, worn tyres, overall motorcycle condition and poor road or weather conditions.

Warning

If the passenger seat is used to carry small objects, they must not exceed 5 kg in weight, must not impair control of the motorcycle, must be securely attached and must not extend beyond the rear or sides of the motorcycle.

Carriage of objects in excess of 5 kg in weight, that are insecure, impair control or extend beyond the rear or sides of the motorcycle may lead to loss of motorcycle control and an accident.

Even if small objects are correctly loaded onto the rear seat, the maximum speed of the motorcycle must be reduced to 80 mph (130 km/h).

Accessories, Loading and Passengers

This page intentionally left blank

Maintenance and Adjustment

MAINTENANCE AND ADJUSTMENT

Table of Contents

Scheduled Maintenance	74
Engine Oil	77
Oil Level Inspection	77
Oil and Oil Filter Change	78
Disposal of Used Engine Oil and Oil Filters	79
Oil Specification and Grade	79
Cooling System	80
Corrosion Inhibitors	80
Coolant Level Inspection	81
Coolant Level Adjustment	82
Coolant Change	82
Radiator and Hoses	83
Throttle Control	83
Inspection	84
Adjustment	84
Clutch	86
Inspection	86
Adjustment	86
Drive Chain	87
Chain Lubrication	87
Chain Free-Movement Inspection	88
Chain Free-Movement Adjustment	88
Chain and Sprocket Wear Inspection	89
Brakes	91
Brake Wear Inspection	91
Breaking-in New Brake Pads and Discs	91
Brake Pad Wear Compensation	92
Disc Brake Fluid	92
Front Brake Fluid Level Inspection and Adjustment	93
Rear Brake Fluid Inspection and Adjustment	93
Brake Light Switches	94

Maintenance and Adjustment

Steering/Wheel Bearings	94
Steering Inspection	94
Inspecting the Steering (Headstock) Bearings for Free Play	95
Wheel Bearings Inspection	95
Front Suspension	96
Front Fork Inspection	96
Rear Suspension	96
Suspension Setting Chart - Tiger 800 only	96
Suspension Setting Chart - Tiger 800XC only	96
Rear Suspension Adjustment	97
Spring Pre-Load Adjustment	97
Rebound Damping Adjustment - Tiger 800XC models only	98
Tyres	98
Tyre Inflation Pressures	100
Tyre Wear	101
Minimum Recommended Tread Depth	101
Tyre Replacement	102
Battery	105
Battery Removal	105
Battery Disposal	106
Battery Maintenance	106
Battery Discharge	106
Battery Maintenance During Storage and Infrequent Use of the Motorcycle	107
Battery Charging	107
Battery Installation	108
Fuse Boxes	108
Fuse Identification	109
Headlights	110
Headlights	110
Headlight Adjustment	111
Headlight Adjustment Lever for Loaded Conditions	111
Headlight Bulb Replacement	112
Rear Light/Licence Plate Light	113
Rear Light/Licence Plate Light Replacement	113

Maintenance and Adjustment

Direction Indicator Lights	113
Bulb Replacement	113
Bank Angle Indicators	114
Cleaning	115
Care of Matt Paintwork	115
Preparation for Washing	115
Where to be Careful	116
After Washing	116
Seat Care	116
Unpainted Aluminium Items	117
Cleaning of the Exhaust System	117
Windscreen Cleaning	117
Washing	118
Drying	118
Protecting	118
Care of Leather Products	119

Maintenance and Adjustment

Scheduled Maintenance

To maintain the motorcycle in a safe and reliable condition, the maintenance and adjustments outlined in this section must be carried out as specified in the schedule of daily checks, and also in line with the scheduled maintenance chart. The information that follows describes the procedures to follow when carrying out the daily checks and some simple maintenance and adjustment items.

Warning

All maintenance is vitally important and must not be neglected. Incorrect maintenance or adjustment may cause one or more parts of the motorcycle to malfunction. A malfunctioning motorcycle may lead to loss of control and an accident. Weather, terrain and geographical location affects maintenance. The maintenance schedule should be adjusted to match the particular environment in which the vehicle is used and the demands of the individual owner.

Special tools, knowledge and training are required in order to correctly carry out the maintenance items listed in the scheduled maintenance chart. Only an authorised Triumph dealer will have this knowledge and equipment.

Since incorrect or neglected maintenance can lead to a dangerous riding condition, always have an authorised Triumph dealer carry out the scheduled maintenance of this motorcycle.

Scheduled maintenance may be carried out by your dealer in three ways; annual maintenance, mileage based maintenance or a combination of both, depending on the mileage the motorcycle travels each year.

1. Motorcycles travelling less than 6,000 miles (10,000 km) per year must be maintained annually. In addition to this, mileage based items require maintenance at their specified intervals, as the motorcycle reaches this mileage.
2. Motorcycles travelling approximately 6,000 miles (10,000 km) per year must have the annual maintenance and the specified mileage based items carried out together.
3. Motorcycles travelling more than 6,000 miles (10,000 km) per year must have the mileage based items maintained as the motorcycle reaches the specified mileage. In addition to this, annual based items will require maintenance at their specified annual intervals.

In all cases maintenance must be carried out at or before the specified maintenance intervals shown. Consult an authorised Triumph dealer for advice on which maintenance schedule is most suitable for your motorcycle.

Triumph Motorcycles cannot accept any responsibility for damage or injury resulting from incorrect maintenance or improper adjustment.

Maintenance and Adjustment

Operation Description	Odometer Reading in Miles (km) or Time Period, whichever comes first					
		First Service	Annual Service	Mileage Based Service		
	Every	500 (800) 1 month	Year	6,000 and 18,000 (10,000) and 30,000	12,000 (20,000)	24,000 (40,000)
Engine oil cooler - check for leaks	Day	*	*	*	*	*
Engine oil - renew	-	*	*	*	*	*
Engine and oil filter - renew	-	*	*	*	*	*
Valve clearances - check/adjust	-				*	*
Air cleaner - renew	-				*	*
Autoscan - carry out a full Autoscan using the Triumph diagnostic tool	-	*	*	*	*	*
ABS and Immobiliser ECMS - check for stored DTCs		*	*	*	*	*
Spark plugs - check	-			*		
Spark plugs - renew	-				*	*
Throttle body plate (butterfly) - check/clean				*	*	*
Throttle bodies - balance	-			*	*	*
Throttle cables - check/adjust	Day	*	*	*	*	*
Cooling system - check for leaks	Day	*	*	*	*	*
Coolant level - check/adjust	Day	*	*	*	*	*
Coolant - renew	Every 3 years, regardless of mileage					
Fuel system - check for leaks, chafing etc.	Day	*	*	*	*	*
Lights, instruments and electrical systems - check	Day	*	*	*	*	*
Steering - check for free operation	Day	*	*	*	*	*
Headstock bearings - check/adjust	-		*	*	*	*
Headstock bearings - lubricate	-				*	*
Forks - check for leaks/smooth operation	Day	*	*	*	*	*
Fork oil - renew	-					*
Brake fluid levels - check	Day	*	*	*	*	*

Maintenance and Adjustment

Operation Description	Odometer Reading in Miles (km) or Time Period, whichever comes first					
		First Service	Annual Service	Mileage Based Service		
	Every	500 (800) 1 month	Year	6,000 and 18,000 (10,000) and 30,000	12,000 (20,000)	24,000 (40,000)
Brake fluid - renew	Every 2 years, regardless of mileage					
Brake pads - check wear levels	Day	*	*	*	*	*
Brake master cylinders - check for fluid leaks	Day	*	*	*	*	*
Brake calipers - check for fluid leaks and seized pistons	Day	*	*	*	*	*
Rear suspension linkage - check/lubricate	-				*	*
Drive chain - lubricate	Every 200 miles (300 km)					
Drive chain - wear check	Every 500 miles (800 km)					
Drive chain slack - check/adjust	Day	*	*	*	*	*
Drive chain rubbing strip - renew	-			*	*	*
Fasteners - inspect visually for security	Day	*	*	*	*	*
Wheels - inspect for damage	Day	*	*	*	*	*
Wheels - check wheels for broken or damaged spokes and check spoke tightness (Tiger 800XC models only)	Day	*	*	*	*	*
Wheel bearings - check for wear/smooth operation	-	*	*	*	*	*
Tyre wear/tyre damage - check	Day	*	*	*	*	*
Tyre pressures - check/adjust	Day	*	*	*	*	*
Clutch cable - check/adjust	Day	*	*	*	*	*
Centre and/or side stand - check operation	Day	*	*	*	*	*
Secondary exhaust clamp bolts - check/adjust	-	*	*	*	*	*
Accessory rack sliding carriage - check for correct operation‡			*	*	*	*
Accessory pannier link mechanism - check for correct operation and adjustment‡		*	*	*	*	*
Fuel and evaporative loss* hoses - renew	Every 4 years, regardless of mileage					

*Evaporative system fitted to models for certain markets only.

‡Only if fitted.

Maintenance and Adjustment

Engine Oil



cbnz

In order for the engine, transmission, and clutch to function correctly, maintain the engine oil at the correct level, and change the oil and oil filter in accordance with scheduled maintenance requirements.

Warning

Motorcycle operation with insufficient, deteriorated, or contaminated engine oil will cause accelerated engine wear and may result in engine or transmission seizure. Seizure of the engine or transmission may lead to sudden loss of control and an accident.

Oil Level Inspection

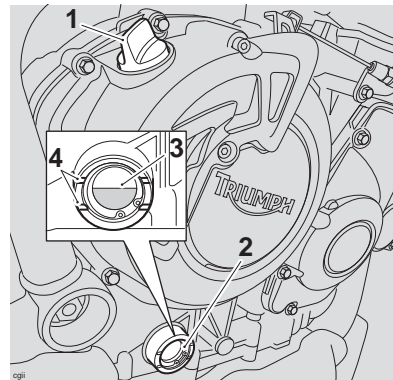

1. Filler
2. Sight glass
3. Oil level (correct level shown)
4. Crankcase oil level lines

Warning

Never start the engine or run the engine in a confined area. Exhaust fumes are poisonous and can cause loss of consciousness and death within a short period of time. Always operate your motorcycle in the open-air or in an area with adequate ventilation.

Caution

Running the engine with insufficient oil will cause engine damage. If the low oil pressure indicator remains on, stop the engine immediately and investigate the cause.

Maintenance and Adjustment

Start the engine and run at idle for approximately five minutes.

Stop the engine, then wait for at least three minutes for the oil to settle.

Note the oil level visible in the sight glass.

When correct, oil should be visible in the sight-glass at a point mid-way between the upper (maximum) and lower (minimum) horizontal lines marked on the crankcase.

Note:

- **An accurate indication of the level of oil in the engine is only shown when the engine is at normal operating temperature and the motorcycle is upright (not on the side stand).**

If it is necessary to top up the oil level, remove the filler plug and add oil, a little at a time, until the level registered in the sight glass is correct.

Once the correct level is reached, fit and tighten the filler plug.

Oil and Oil Filter Change

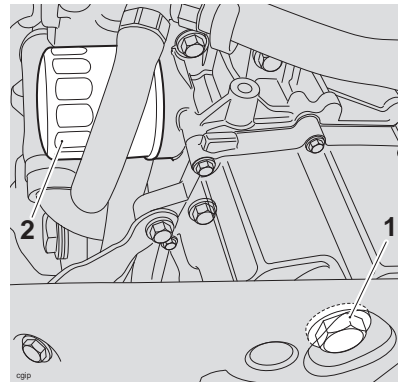

1. Oil drain plug
2. Oil filter

The engine oil and filter must be replaced in accordance with scheduled maintenance requirements.

Warning

Prolonged or repeated contact with engine oil can lead to skin dryness, irritation and dermatitis. In addition, used engine oil contains harmful contamination that can lead to skin cancer. Always wear suitable protective clothing and avoid skin contact with used oil.

Warm up the engine thoroughly, and then stop the engine and secure the motorcycle in an upright position on level ground.

Place an oil drain pan beneath the engine.

Remove the oil drain plug.

Maintenance and Adjustment

Warning

The oil may be hot to the touch. Avoid contact with the hot oil by wearing suitable protective clothing, gloves, eye protection, etc. Contact with hot oil may cause the skin to be scalded or burned.

Unscrew and remove the oil filter using Triumph service tool T3880313. Dispose of the old filter in an environmentally friendly way.

Apply a thin smear of clean engine oil to the sealing ring of the new oil filter. Fit the oil filter and tighten to **10 Nm**.

After the oil has completely drained out, fit a new sealing washer to the drain plug. Fit and tighten the plug to **25 Nm**.

Fill the engine with a 10W/40 or 10W/50 semi or fully synthetic motorcycle engine oil that meets specification API SH (or higher) and JASO MA, such as Castrol Power 1 Racing 4T 10W-40 (fully synthetic).

Start the engine and allow it to idle for a minimum of 30 seconds.

Caution

Raising the engine speed above idle before the oil reaches all parts of the engine can cause engine damage or seizure. Only raise engine speed after running the engine for 30 seconds to allow the oil to circulate fully.

Caution

If the engine oil pressure is too low, the low oil pressure warning light will illuminate. If this light stays on when the engine is running, stop the engine immediately and investigate the cause. Running the engine with low oil pressure will cause engine damage.

Ensure that the low oil pressure warning light extinguishes shortly after starting.

Stop the engine and re-check the oil level. Adjust if necessary.

Disposal of Used Engine Oil and Oil Filters

To protect the environment, do not pour oil on the ground, down sewers or drains, or into watercourses. Do not place used oil filters in with general waste. If in doubt, contact your local authority.

Oil Specification and Grade

Triumph high performance fuel injected engines are designed to use 10W/40 or 10W/50 semi or fully synthetic motorcycle engine oil that meets specification API SH (or higher) and JASO MA, such as Castrol Power 1 Racing 4T 10W-40 (fully synthetic) engine oil, sold as Castrol Power RS Racing 4T 10W-40 (fully synthetic) in some countries.

Do not add any chemical additives to the engine oil. The engine oil also lubricates the clutch and any additives could cause the clutch to slip.

Maintenance and Adjustment

Do not use mineral, vegetable, non-detergent oil, castor based oils or any oil not conforming to the required specification. The use of these oils may cause instant, severe engine damage.

Cooling System



To ensure efficient engine cooling, check the coolant level each day before riding the motorcycle, and top up the coolant if the level is low.

Note:

- **A year-round, Hybrid Organic Acid Technology (known as Hybrid OAT or HOAT) coolant is installed in the cooling system when the motorcycle leaves the factory. It is coloured green, contains a 50% solution of ethylene glycol based antifreeze, and has a freezing point of -35°C (-31°F).**

Corrosion Inhibitors

To protect the cooling system from corrosion, the use of corrosion inhibitor chemicals in the coolant is essential.

If coolant containing a corrosion inhibitor is not used, the cooling system will accumulate rust and scale in the water jacket and radiator. This will block the coolant passages, and considerably reduce the efficiency of the cooling system.

Maintenance and Adjustment

Warning

HD4X Hybrid OAT coolant contains corrosion inhibitors and anti-freeze suitable for aluminium engines and radiators. Always use the coolant in accordance with the instructions of the manufacturer.

Coolant that contains anti-freeze and corrosion inhibitors contains toxic chemicals that are harmful to the human body. Never swallow anti-freeze or any of the motorcycle coolant.

Note:

- **HD4X Hybrid OAT coolant, as supplied by Triumph, is pre-mixed and does not need to be diluted prior to filling or topping up the cooling system.**

Coolant Level Inspection

Note:

- **The coolant level should be checked when the engine is cold (at room or ambient temperature).**

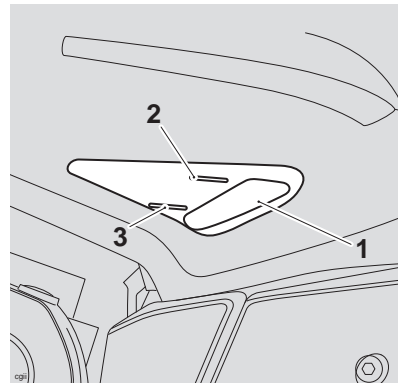

1. Expansion tank
2. MAX mark
3. MIN mark

Position the motorcycle on level ground and in an upright position. The expansion tank can be viewed from the right hand of the motorcycle, below and towards the front of the fuel tank.

Check the coolant level in the expansion tank. The coolant level must be between the MAX and MIN marks. If the coolant is below the minimum level, the coolant level must be adjusted.

Maintenance and Adjustment

Coolant Level Adjustment

Warning

Do not remove the expansion tank or radiator pressure cap when the engine is hot. When the engine is hot, the coolant inside the radiator will be hot and also under pressure. Contact with this hot, pressurised coolant will cause scalds and skin damage.

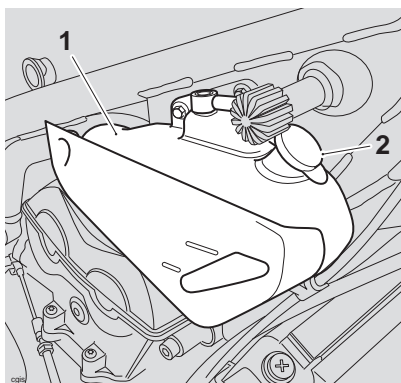

1. Expansion tank (fuel tank shown removed for clarity)
2. Expansion tank cap

Allow the engine to cool.

The expansion tank cap can be removed from the right hand side of the motorcycle, between the front of the fuel tank and the frame.

Remove the cap from the expansion tank and add coolant mixture through the filler opening until the level reaches the MAX mark. Refit the cap.

Note:

- If the coolant level is being checked because the coolant has overheated, also check the level in the radiator and top up if necessary.
- In an emergency, distilled water can be added to the cooling system. However, the coolant must then be drained and replenished with HD4X Hybrid OAT coolant as soon as possible.

Caution

If hard water is used in the cooling system, it will cause scale accumulation in the engine and radiator and considerably reduce the efficiency of the cooling system. Reduced cooling system efficiency may cause the engine to overheat and suffer severe damage.

Coolant Change

Have the coolant changed by an authorised Triumph dealer in accordance with scheduled maintenance requirements.

Maintenance and Adjustment

Radiator and Hoses

Check the radiator hoses for cracks or deterioration, and hose clips for tightness in accordance with scheduled maintenance requirements. Have your authorised Triumph dealer replace any defective items.

Check the radiator grille and fins for obstructions by insects, leaves or mud. Clean off any obstructions with a stream of low-pressure water.

Warning

The fan operates automatically when the engine is running. Always keep hands and clothing away from the fan as contact with the rotating fan can cause injury.

Caution

Using high-pressure water sprays, such as from a car wash facility or household pressure washer, can damage the radiator fins, cause leaks and impair the radiator's efficiency.

Do not obstruct or deflect airflow through the radiator by installing unauthorised accessories, either in front of the radiator or behind the cooling fan. Interference with the radiator airflow can cause overheating, potentially resulting in engine damage.

Throttle Control

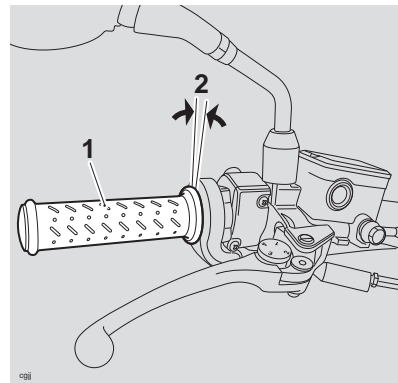

1. Throttle grip
2. Correct setting 2 - 3 mm

Warning

The throttle grip controls the throttle valves in the throttle bodies. If the throttle cables are incorrectly adjusted, either too tight or too loose, the throttle may be difficult to control and performance will be adversely affected.

Check the throttle grip free play in accordance with scheduled maintenance requirements and make adjustments as necessary.

Maintenance and Adjustment

Warning

Always be alert for changes in the 'feel' of the throttle and have the throttle system checked by an authorised Triumph dealer if any changes are detected. Changes can be due to wear in the mechanism, which could lead to a sticking throttle.

An incorrectly adjusted, sticking or stuck throttle will lead to loss of motorcycle control and an accident.

Inspection

Warning

Use of the motorcycle with incorrectly adjusted, incorrectly routed, sticking or damaged throttle cables will interfere with the throttle function resulting in loss of motorcycle control and an accident.

To avoid incorrect adjustment, incorrect routing, or continued use of a sticking or damaged throttle, always have your throttle checked and adjusted by your authorised Triumph dealer.

Check that the throttle opens smoothly, without undue force and that it closes without sticking. Have your authorised Triumph dealer check the throttle system if a problem is detected or any doubt exists.

Check that there is 2 - 3 mm of throttle grip free play when lightly turning the throttle grip back and forth.

If there is an incorrect amount of free play, Triumph recommends that you have adjustments made by your authorised Triumph dealer. However, in an emergency, throttle adjustment may be made as follows:

Adjustment

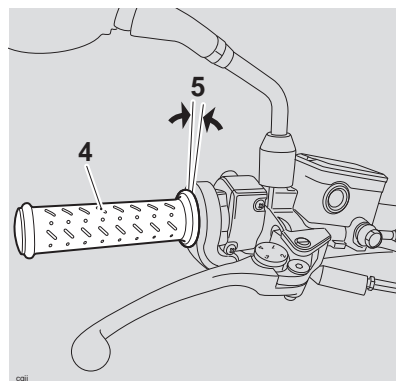
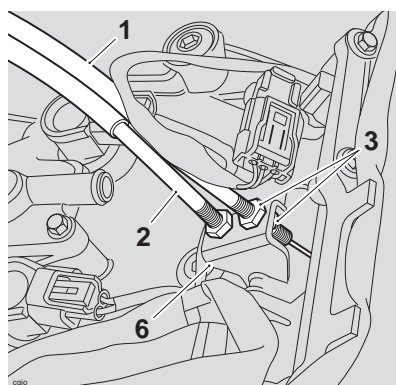

1. Opening cable
2. Closing cable
3. Opening cable adjuster lock nuts
4. Throttle grip
5. Opening cable – free play measurement point
6. Closing cable – free play measurement point

Maintenance and Adjustment

Remove the seat.

Disconnect the battery, negative (black) lead first.

Remove the fuel tank.

Release the lock nuts on the 'opening' cable adjusters.

Rotate the 'opening' cable adjuster at the throttle grip end such that it has an equal amount of adjustment in each direction.

Rotate the 'opening' cable adjuster at the throttle body end of the cable to give 2 - 3 mm of play at the throttle grip. Tighten the lock nut.

Make any minor adjustments as necessary to give 2 - 3 mm of play using the adjuster near the throttle grip end of the cable. Tighten the adjuster lock nut.

With the throttle fully closed, ensure that there is 2 - 3 mm of free play in the 'closing' cable at the throttle cam attached to the throttle bodies. If necessary, adjust at the throttle body end in the same way as the 'opening' cable, until 2 - 3 mm of play is present.

Tighten the adjuster lock nuts.

Refit the fuel tank.

Reconnect the battery, positive (red) lead first.

Refit the rider's seat.

Check that the throttle opens smoothly, without undue force and that it closes without sticking.

Ride carefully to your nearest authorised Triumph dealer and have him check the throttle system thoroughly before riding again.

Warning

Ensure that all the adjuster lock nuts of all cables are tightened, as a loose lock nut could result in a sticking throttle.

An incorrectly adjusted, sticking or stuck throttle can lead to loss of motorcycle control and an accident.

Maintenance and Adjustment

Clutch

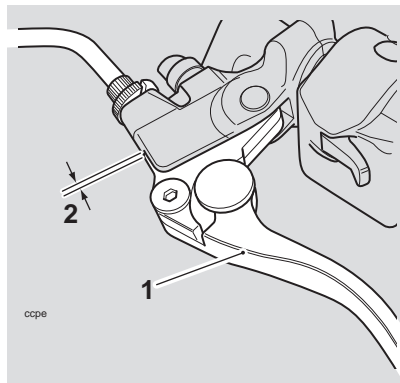

1. Clutch lever
2. 2 - 3 mm

The motorcycle is equipped with a cable-operated clutch.

If the clutch lever has excessive free play, the clutch may not disengage fully. This will cause difficulty in changing gear and selecting neutral. This may cause the engine to stall and make the motorcycle difficult to control.

Conversely, if the clutch lever has insufficient free play the clutch may not engage fully, causing the clutch to slip, which will reduce performance and cause premature clutch wear.

Clutch lever free play must be checked in accordance with scheduled maintenance requirements.

Inspection

Check that there is 2 - 3 mm clutch lever free play at the lever.

If there is an incorrect amount of free play, adjustments must be made.

Adjustment

Turn the adjuster sleeve until the correct amount of clutch lever free play is achieved.

If correct adjustment cannot be made using the lever adjuster, use the cable adjuster at the lower end of the cable.

Loosen the adjuster lock nut.

Turn the outer cable adjuster to give 2 - 3 mm of free play at the clutch lever.

Tighten the lock nut.

Maintenance and Adjustment

Drive Chain



For safety and to prevent excessive wear the drive chain must be checked, adjusted and lubricated in accordance with scheduled maintenance requirements. Checking, adjustment and lubrication must be carried out more frequently for extreme conditions such as salty or heavily gritted roads.

If the chain is badly worn or incorrectly adjusted (either too loose or too tight) the chain could jump off the sprockets or break. Therefore, always replace worn or damaged chains using genuine Triumph parts supplied by an authorised Triumph dealer.

Warning

A loose or worn chain, or a chain that breaks or jumps off the sprockets could catch on the engine sprocket or lock the rear wheel.

A chain that snags on the engine sprocket will injure the rider and lead to loss of motorcycle control and an accident.

Similarly, locking the rear wheel will lead to loss of motorcycle control and an accident.

Chain Lubrication

Lubrication is necessary every 200 miles (300 km) and also after riding in wet weather, on wet roads, or any time that the chain appears dry.

Use the special chain lubricant as recommended in the Specification section.

Apply lubricant to the sides of the rollers then allow the motorcycle to stand unused for at least 8 hours (overnight is ideal). This will allow the oil to penetrate to the chain O-rings etc.

Before riding, wipe off any excess oil.

If the chain is especially dirty, clean first and then apply oil as mentioned above.

Caution

Do not use a pressure wash to clean the chain as this may cause damage to the chain components.

Maintenance and Adjustment

Chain Free-Movement Inspection

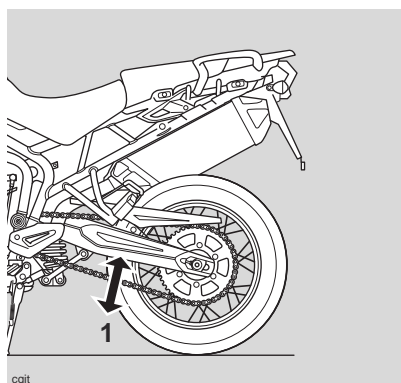

1. Maximum movement position

Warning

Before starting work, ensure the motorcycle is stabilised and adequately supported. This will help prevent injury to the operator or damage to the motorcycle.

Place the motorcycle on a level surface and hold it in an upright position with no weight on it.

Rotate the rear wheel by pushing the motorcycle to find the position where the chain is tightest, and measure the vertical movement of the chain midway between the sprockets.

Chain Free-Movement Adjustment

The vertical movement of the drive chain must be in the range 20 - 30 mm.

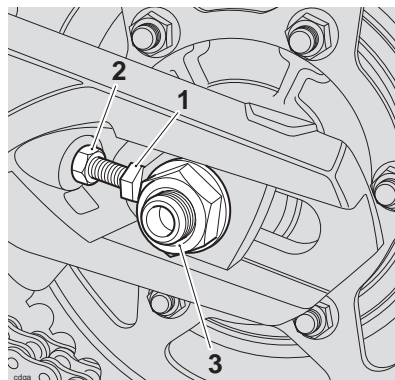

1. Adjuster bolt
2. Adjuster bolt lock nut
3. Rear wheel spindle nut

Loosen the wheel spindle nut.

Release the lock nuts on both the left hand and right hand chain adjuster bolts.

Moving both adjusters by an equal amount, turn the adjuster bolts clockwise to increase chain free-movement and anti-clockwise to reduce chain free-movement.

Maintenance and Adjustment

When the correct amount of chain free-movement has been set, push the wheel into firm contact with the adjuster. Tighten both adjuster lock nuts to **20 Nm** and the rear wheel spindle nut to **110 Nm**.

Repeat the chain adjustment check. Re-adjust if necessary.

Warning

Operation of the motorcycle with insecure adjuster lock nuts or a loose wheel spindle may result in impaired stability and handling of the motorcycle. This impaired stability and handling may lead to loss of control or an accident.

Check the rear brake effectiveness. Rectify if necessary.

Warning

It is dangerous to operate the motorcycle with defective brakes; you must have your authorised Triumph dealer take remedial action before you attempt to ride the motorcycle again. Failure to take remedial action may reduce braking efficiency leading to loss of control or an accident.

Chain and Sprocket Wear Inspection

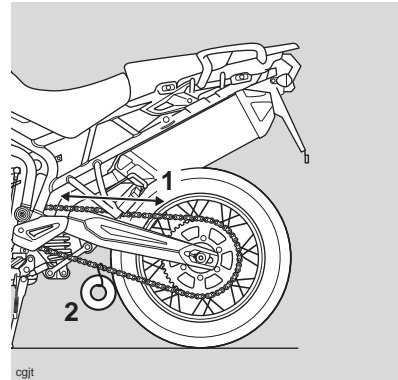

1. **Measure across 20 links**
2. **Weight**

Remove the chain guard.

Stretch the chain taut by hanging a 10 - 20 kg weight on the chain.

Measure the length of 20 links on the straight part of the chain from pin centre of the 1st pin to the pin centre of the 21st pin. Since the chain may wear unevenly, take measurements in several places.

If the length exceeds the maximum service limit of 319 mm, the chain must be replaced.

Rotate the rear wheel and inspect the drive chain for damaged rollers, and loose pins and links.

Maintenance and Adjustment

Also inspect the sprockets for unevenly or excessively worn or damaged teeth.

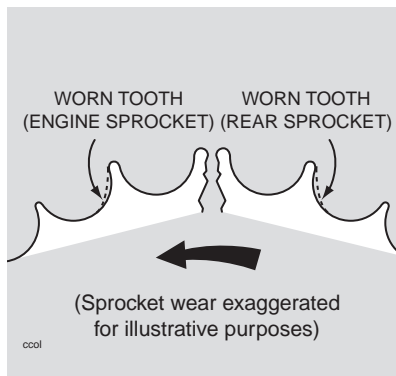

If there is any irregularity, have the drive chain and/or the sprockets replaced by an authorised Triumph dealer.

Replace the chain guard.

Caution

If the sprockets are found to be worn, always replace the sprockets and drive chain together.

Replacing worn sprockets without also replacing the chain will lead to premature wear of the new sprockets.

Warning

The use of non-approved chains may result in a broken chain or may cause the chain to jump off the sprockets.

Use a genuine Triumph supplied chain as specified in the Triumph Parts Catalogue.

Never neglect chain maintenance and always have chains installed by an authorised Triumph dealer.

Maintenance and Adjustment

Brakes

Brake Wear Inspection

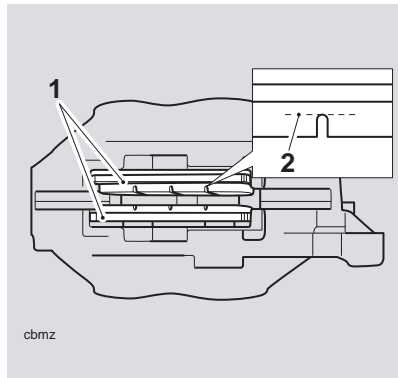

1. Brake pads
2. Minimum thickness line

Brake pads must be inspected in accordance with scheduled requirements and replaced if worn to, or beyond the minimum service thickness.

If the lining thickness of any pad (front or rear brakes) is less than 1.5 mm (0.06 in), that is, if the pad has worn down to the bottom of the grooves, replace all the pads on the wheel.

Breaking-in New Brake Pads and Discs

After replacement brake discs and/or pads have been fitted to the motorcycle, we recommend a period of careful breaking-in that will optimise the performance and longevity of the discs and pads. The recommended distance for breaking-in new pads and discs is 200 miles (300 km).

After fitting new brake discs and/or pads avoid extreme braking, ride with caution and allow for greater braking distances during the breaking-in period.

Warning

Brake pads must always be replaced as a wheel set. At the front, where two calipers are fitted on the same wheel, replace all the brake pads in both calipers.

Replacing individual pads will reduce braking efficiency and may cause an accident.

After replacement brake pads have been fitted, ride with extreme caution until the new pads have 'broken in'.

Warning

Brake pad wear will be increased if the motorcycle is used frequently off-road. Always inspect the brake pads more frequently if the motorcycle is used off-road, and replace the brake pads before they become worn to, or beyond the minimum service thickness.

Riding with worn brake pads may reduce braking efficiency, leading to loss of motorcycle control and an accident.

Maintenance and Adjustment

Brake Pad Wear Compensation

Disc and brake pad wear is automatically compensated for and has no effect on the brake lever or pedal action. There are no parts that require adjustment on the front and rear brakes.

Warning

If the brake lever or pedal feels soft when it is applied, or if the lever/pedal travel becomes excessive, there may be air in the brake pipes and hoses or the brakes may be defective.

It is dangerous to operate the motorcycle under such conditions and your authorised Triumph dealer must rectify the fault before riding.

Riding with defective brakes may lead to loss of motorcycle control and an accident.

Disc Brake Fluid

Inspect the level of brake fluid in both reservoirs and change the brake fluid in accordance with scheduled maintenance requirements. Use only DOT 4 fluid as recommended in the Specification section. The brake fluid must also be changed if it becomes, or is suspected of having become contaminated with moisture or any other contaminants.

Warning

Brake fluid is hygroscopic which means it will absorb moisture from the air.

Any absorbed moisture will greatly reduce the boiling point of the brake fluid causing a reduction in braking efficiency.

Because of this, always replace brake fluid in accordance with scheduled maintenance requirements.

Always use new brake fluid from a sealed container and never use fluid from an unsealed container or from one which has been previously opened.

Do not mix different brands or grades of brake fluid.

Check for fluid leakage around brake fittings, seals and joints and also check the brake hoses for splits, deterioration and damage.

Always rectify any faults before riding.

Failure to observe and act upon any of these items may cause a dangerous riding condition leading to loss of control and an accident.

Maintenance and Adjustment

Front Brake Fluid Level Inspection and Adjustment

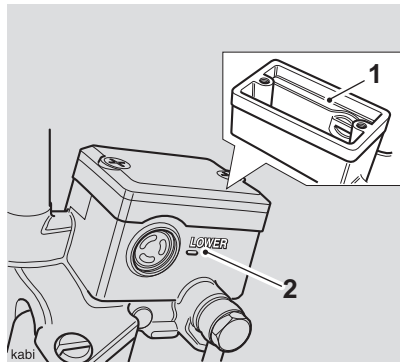

1. Front brake fluid reservoir, upper level line
2. Lower level line

The brake fluid level in the reservoirs must be kept between the upper and lower level lines (reservoir held horizontal).

To inspect the fluid level, check the level of fluid visible in the window at the front of the reservoir body.

To adjust the fluid level, release the cap screws and detach the cover noting the position of the sealing diaphragm.

Fill the reservoir to the upper level line using new DOT 4 fluid from a sealed container.

Refit the cover, ensuring that the diaphragm seal is correctly positioned between the cap and reservoir body. Tighten the cap retaining screws to **1.5 Nm**.

Rear Brake Fluid Inspection and Adjustment

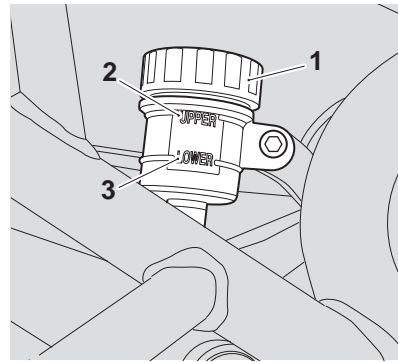

1. Rear brake fluid reservoir
2. Upper level line
3. Lower level line

To inspect the fluid level:

The reservoir is visible from the right hand side of the motorcycle, forward of the exhaust intermediate pipe, below the rider's seat.

To adjust the fluid level:

Remove the reservoir cap. Fill the reservoir to the upper level line using new DOT 4 fluid from a sealed container.

Refit the reservoir cap ensuring that the diaphragm seal is correctly fitted.

Maintenance and Adjustment

Warning

If there has been an appreciable drop in the level of the fluid in either fluid reservoir, consult your authorised Triumph dealer for advice before riding. Riding with depleted brake fluid levels, or with a brake fluid leak is dangerous and will cause reduced brake performance potentially leading to loss of motorcycle control and an accident.

Brake Light Switches

The brake light is activated independently by either the front or rear brake. If, with the ignition in the ON position, the brake light does not work when the front brake lever is pulled or the rear brake pedal is pressed, have your authorised Triumph dealer investigate and rectify the fault.

Warning

Riding the motorcycle with defective brake lights is illegal and dangerous.
An accident causing injury to the rider and other road users may result from use of a motorcycle with defective brake lights.

Steering/Wheel Bearings

Caution

To prevent risk of injury from the motorcycle falling during the inspection, ensure that the motorcycle is stabilised and secured on a suitable support. Do not exert extreme force against each wheel or rock each wheel vigorously as this may cause the motorcycle to become unstable and cause injury by falling from its support. Ensure that the position of the support block will not cause damage to the sump.

Steering Inspection

Lubricate and inspect the condition of the steering (headstock) bearings in accordance with scheduled maintenance requirements.

Note:

- **Always inspect the wheel bearings at the same time as the steering bearings.**

Maintenance and Adjustment

Inspecting the Steering (Headstock) Bearings for Free Play

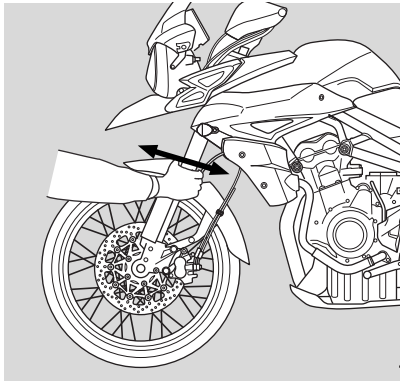

Inspecting the Steering for Free Play

Inspection

Position the motorcycle on level ground, in an upright position.

Raise the front wheel above the ground and support the motorcycle.

Standing at the front of the motorcycle, hold the lower end of the front forks and try to move them forward and backward.

If any free play can be detected in the steering (headstock) bearings, ask your authorised Triumph dealer to inspect and rectify any faults before riding.

Warning

Riding the motorcycle with incorrectly adjusted or defective steering (headstock) bearings is dangerous and may cause loss of motorcycle control and an accident.

Remove the support and place the motorcycle on the side stand.

Wheel Bearings Inspection

If the wheel bearings in the front or rear wheel allow play in the wheel hub, are noisy, or if the wheel does not turn smoothly, have your authorised Triumph dealer inspect the wheel bearings.

The wheel bearings must be inspected at the intervals specified in the scheduled maintenance chart.

Position the motorcycle on level ground, in an upright position.

Raise the front wheel above the ground and support the motorcycle.

Standing at the side of the motorcycle, gently rock the top of the front wheel from side to side.

If any free play can be detected, ask your authorised Triumph dealer to inspect and rectify any faults before riding.

Reposition the lifting device and repeat the procedure for the rear wheel.

Warning

Operation with worn or damaged front or rear wheel bearings is dangerous and may cause impaired handling and instability leading to an accident. If in doubt, have the motorcycle inspected by an authorised Triumph dealer before riding.

Remove the support and place the motorcycle on the side stand.

Maintenance and Adjustment

Front Suspension

Front Fork Inspection

Examine each fork for any sign of damage, scratching of the slider surface, or for oil leaks.

If any damage or leakage is found, consult an authorised Triumph dealer.

To check that the forks operate smoothly:

- Position the motorcycle on level ground.
- While holding the handlebars and applying the front brake, pump the forks up and down several times.
- If roughness or excessive stiffness is detected, consult your authorised Triumph dealer.

 Warning
Riding the motorcycle with defective or damaged suspension is dangerous and may lead to loss of control and an accident.

 Warning
Never attempt to dismantle any part of the suspension units, as all units contain pressurised oil. Skin and eye damage can result from contact with the pressurised oil.

Rear Suspension

Suspension Setting Chart - Tiger 800 only

Loading	Spring Pre-Load ¹
Solo Riding	30
Rider and Luggage	0
Rider and Passenger, or Rider, Passenger and Luggage	0

¹ Number of **clicks** anti-clockwise from the fully clockwise (hardest) position.

Suspension Setting Chart - Tiger 800XC only

Loading	Spring Pre-Load ¹	Rebound Damping ²
Solo Riding	24	1.5
Rider and Luggage	0	1
Rider and Passenger, or Rider, Passenger and Luggage	0	0.5
Off-Road Use	0	0.5

¹ Number of **clicks** anti-clockwise from the fully clockwise (hardest) position.

² Number of **turns** anti-clockwise from the fully clockwise (hardest) position.

The standard suspension settings provide a comfortable ride and good handling characteristics for general, solo riding. The charts above show suggested settings for the rear suspension.

Maintenance and Adjustment

An increase in spring pre-load requires firmer damping, a reduction in spring pre-load requires softer damping.

The damping must be adjusted to the road conditions and the spring pre-load.

Warning

Ensure that the correct balance between front and rear suspension is maintained. Suspension imbalance could significantly change handling characteristics leading to loss of control and an accident. Refer to the the front and rear suspension setting charts for further information or consult your dealer.

Note:

- **The Tiger 800 and the Tiger 800XC are delivered from the factory with the rear suspension set at the standard settings, as shown in the relevant suspension chart (see page 96).**
- **These charts are only a guide. Setting requirements may vary for rider weight and personal preferences. See the following pages for information regarding suspension adjustment.**

Rear Suspension Adjustment

The rear suspension unit on Tiger 800 is adjustable for spring pre-load. The rear suspension unit on Tiger 800XC is adjustable for spring pre-load and rebound damping.

Spring Pre-Load Adjustment

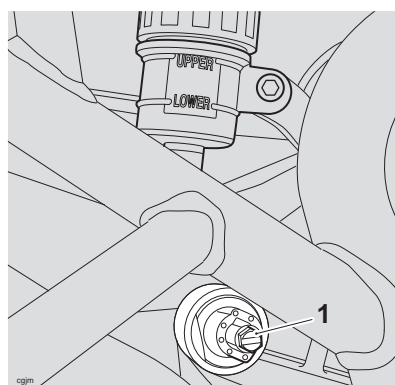

1. Spring pre-load adjuster

The spring pre-load adjuster is situated on the right hand side of the motorcycle, at the top of the rear suspension unit.

To adjust the spring pre-load setting rotate the slotted adjuster clockwise to increase, or anti-clockwise to decrease.

Note:

- **The setting is measured as the number of adjuster 'clicks' anti-clockwise from the fully clockwise (hardest) position.**
- **The Tiger 800 is delivered from the factory with the spring pre-load set to 30 'clicks' anti-clockwise from the fully clockwise position.**
- **The Tiger 800XC is delivered from the factory with the spring pre-load set to 24 'clicks' anti-clockwise from the fully clockwise position.**

Maintenance and Adjustment

Rebound Damping Adjustment - Tiger 800XC models only

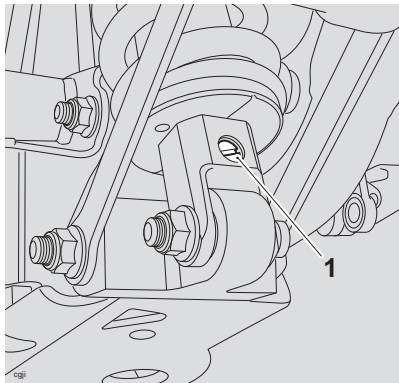

1. Rebound damping adjuster

The rebound damping adjuster is located at the bottom of the rear suspension unit and is accessible from either side of the motorcycle.

To adjust the rebound damping setting, rotate the slotted adjuster clockwise to increase, and anti-clockwise to decrease.

Note:

- **The setting is measured as the number of adjuster turns anti-clockwise from the fully clockwise (hardest) position.**
- **The Tiger 800XC is delivered from the factory with the rebound adjuster set to 1.5 turns anti-clockwise from the fully clockwise position.**

Tyres



0008

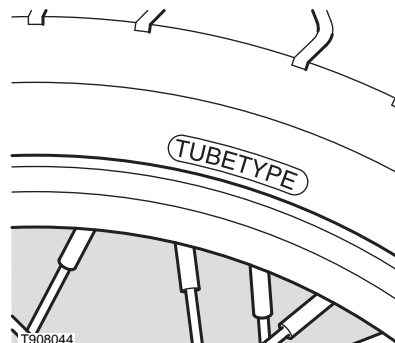

T908044

Typical Tyre Marking

Tiger 800XC models are fitted with spoked wheels which require a tyre suitable for use with an inner tube.

Warning

Failure to use an inner tube in a spoked wheel will cause deflation of the tyre resulting in loss of motorcycle control and an accident.

Tiger 800 models are equipped with tubeless tyres, valves and wheel rims. Use only tyres marked 'TUBELESS' and tubeless valves on rims marked 'SUITABLE FOR TUBELESS TYRES'.

Maintenance and Adjustment

Warning

Do not install tube-type tyres on tubeless rims. The bead will not seat and the tyres could slip on the rims, causing rapid tyre deflation that may result in a loss of vehicle control and an accident. Never install an inner tube inside a tubeless tyre. This will cause friction inside the tyre and the resulting heat build-up may cause the tube to burst resulting in rapid tyre deflation, loss of vehicle control and an accident.

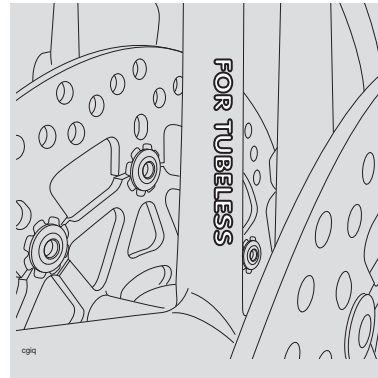

**Wheel Marking -
Tubeless Wheel**

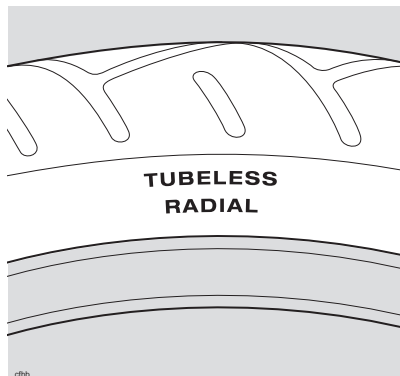

**Typical Tyre Marking -
Tubeless Tyre**

Maintenance and Adjustment

Warning

Inner tubes must only be used on motorcycles fitted with spoked wheels and with tyres marked 'TUBE TYPE'.

Some brands of approved tyre marked 'TUBELESS' may be suitable for use with an inner tube. Where this is the case, the tyre wall will be marked with text permitting the fitment of an inner tube (see illustration below).

Use of an inner tube with a tyre marked 'TUBELESS', and NOT marked as suitable for use with an inner tube, or use of an inner tube on an alloy wheel marked 'SUITABLE FOR TUBELESS TYRES' will cause deflation of the tyre resulting in loss of motorcycle control and an accident.

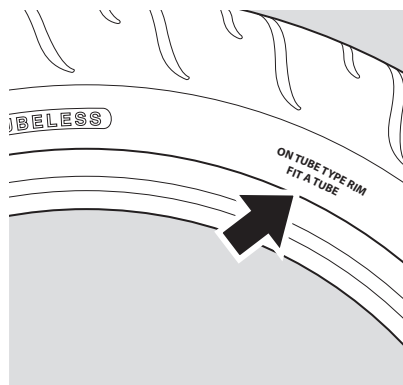

Typical Tyre Marking - Tubeless Tyre Suitable For Use With An Inner Tube

Tyre Inflation Pressures

Correct tyre inflation pressures will provide maximum stability, rider comfort and tyre life. Always check tyre pressures before riding when the tyres are cold. Check tyre pressures daily and adjust if necessary (see Specification section for correct inflation pressures). Alternatively, ask your authorised Triumph dealer to inspect your wheels and tyres.

Tyre Pressure Monitoring System (if fitted)

The tyre pressures shown on your instruments indicate the actual tyre pressure at the time of selecting the display. This may differ from the inflation pressure set when the tyres are cold because tyres become warmer during riding, causing the air in the tyre to expand and increase the inflation pressure. The cold inflation pressures specified by Triumph take account of this.

Owners must only adjust tyre pressures when the tyres are cold using an accurate pressure gauge, and must not use the tyre pressure display on the instruments.

Warning

Incorrect tyre inflation will cause abnormal tread wear and instability problems which may lead to loss of control and an accident.

Under-inflation may result in the tyre slipping on, or coming off the rim. Over-inflation will cause instability and accelerated tread wear.

Both conditions are dangerous as they may cause loss of control leading to an accident.

Maintenance and Adjustment

Warning

Tyre pressures which have been reduced for off-road riding will impair on-road stability. Always ensure the tyre pressure are set as described in the Specification section for on-road use.

Operation of the motorcycle with incorrect tyre pressures may cause loss of motorcycle control leading to an accident.

Tyre Wear



cb0a

As the tyre tread wears down, the tyre becomes more susceptible to punctures. It is estimated that 90% of all tyre problems occur during the last 10% of tread life (90% worn). It is therefore not recommended to use tyres until they are worn to their minimum.

Minimum Recommended Tread Depth

In accordance with the periodic maintenance chart, measure the depth of the tread with a depth gauge, and replace any tyre that has worn to, or beyond, the minimum allowable tread depth specified in the table below:

Under 130 km/h (80 mph)	2 mm (0.08 in)
Over 130 km/h (80 mph)	Rear 3 mm (0.12 in) Front 2 mm (0.08 in)

Warning

This motorcycle must not be operated above the legal road speed limit except in authorised closed-course conditions.

Warning

Only operate this Triumph motorcycle at high speed in closed-course on-road competition or on closed-course racetracks. High-speed operation should only then be attempted by riders who have been instructed in the techniques necessary for high-speed riding and are familiar with the motorcycle's characteristics in all conditions. High-speed operation in any other circumstances is dangerous and will lead to loss of motorcycle control and an accident.

Maintenance and Adjustment

Warning

Operation with excessively worn tyres is hazardous and will adversely affect traction, stability and handling which may lead to loss of control and an accident.

When tyres become punctured, leakage is often very slow. Always inspect tyres very closely for punctures. Check the tyres for cuts, embedded nails or other sharp objects. Operation with punctured or damaged tyres will adversely affect stability and handling which may lead to loss of control or an accident.

Check the rims for dents or deformation and spokes for looseness and damage. Operation with damaged or defective wheels, spokes or tyres is dangerous and loss of control or an accident could result.

Always consult your authorised Triumph dealer for tyre replacement, or for a safety inspection of the wheels, spokes and tyres.

Tyre Replacement

Warning

Inner tubes must only be used on motorcycles fitted with spoked wheels and with tyres marked 'TUBE TYPE'.

Use of an inner tube with a tyre marked 'TUBELESS' and/or on an alloy wheel can lead to loss of motorcycle control and an accident.

Warning

Do not install tube-type tyres on tubeless rims. The bead will not seat and the tyres could slip on the rims, causing rapid tyre deflation that may result in a loss of vehicle control and an accident. Never install an inner tube inside a tubeless tyre. This will cause friction inside the tyre and the resulting heat build-up may cause the tube to burst resulting in rapid tyre deflation, loss of vehicle control and an accident.

Note:

- **Some brands of approved tyre marked 'TUBELESS' may be suitable for use with an inner tube. Where this is the case, the tyre wall will be marked with text permitting the fitment of an inner tube.**

All Triumph motorcycles are carefully and extensively tested in a range of riding conditions to ensure that the most effective tyre combinations are approved for use on each model. It is essential that approved tyres and inner tubes (if installed) fitted in approved combinations, are used when purchasing replacement items. The use of non-approved tyres and inner tubes, or approved tyres and inner tubes in non-approved combinations, may lead to motorcycle instability, loss of control and an accident.

On models fitted with ABS, different wheel speeds, caused by non-approved tyres, can affect the function of the ABS computer.

Maintenance and Adjustment

See the Specification section for details of approved tyre and inner tube combinations. Always have tyres and inner tubes fitted and balanced by your authorised Triumph dealer who has the necessary training and skills to ensure safe, effective fitment.

Tyre Pressure Monitoring System (Only on models fitted with TPMS)

Caution

An adhesive label is fitted to the wheel rim to indicate the position of the tyre pressure sensor. Care must be taken when replacing the tyres to prevent any damage to the tyre pressure sensors. Always have your tyres fitted by your authorised Triumph dealer and inform them that tyre pressure sensors are fitted to the wheels.

Caution

Do not use anti puncture fluid or any other item likely to obstruct air flow to the TPMS sensor's orifices. Any blockage to the air pressure orifice of the TPMS sensor during operation will cause the sensor to become blocked, causing irreparable damage to the TPMS sensor assembly. Damage caused by the use of anti puncture fluid or incorrect maintenance is not considered a manufacturing defect and will not be covered under warranty. Always have your tyres fitted by your authorised Triumph dealer and inform them that tyre pressure sensors are fitted to the wheels.

Warning

If a tyre or inner tube sustains a puncture, the tyre and inner tube must be replaced. Failure to replace a punctured tyre and inner tube, or operation with a repaired tyre or inner tube can lead to instability, loss of motorcycle control or an accident.

Warning

If tyre or inner tube damage is suspected, such as after striking the kerb, ask your authorised Triumph dealer to inspect the tyre both internally and externally and to also inspect the inner tube. Remember, tyre damage may not always be visible from the outside. Operation of the motorcycle with damaged tyres could lead to loss of control and an accident.

Maintenance and Adjustment

Warning

When replacement tyres or inner tubes are required, consult your authorised Triumph dealer who will arrange for the tyres and inner tubes to be selected, in a correct combination, from the approved list and fitted according to the tyre and inner tube manufacturer's instructions.

When tyres and inner tubes are replaced, allow time for the tyres and inner tubes to seat to the rim (approximately 24 hours). During this seating period, ride cautiously as an incorrectly seated tyre or inner tube could cause instability, loss of motorcycle control and an accident.

Initially, the new tyres and inner tubes will not produce the same handling characteristics as the worn tyres and inner tubes and the rider must allow adequate riding distance (approximately 100 miles (160 km)) to become accustomed to the new handling characteristics.

24 hours after fitting, the tyre pressures must be checked and adjusted, and the tyres and inner tubes examined for correct seating. Rectification must be carried out as necessary.

The same checks and adjustments must also be carried out when 100 miles (160 km) have been travelled after fitting.

Use of a motorcycle with incorrectly seated tyres or inner tubes, incorrectly adjusted tyre pressures, or when not accustomed to its handling characteristics may lead to loss of motorcycle control and an accident.

Warning

Tyres and inner tubes that have been used on a rolling road dynamometer may become damaged. In some cases, the damage may not be visible on the external surface of the tyre.

Tyres and inner tubes must be replaced after such use as continued use of a damaged tyre or inner tube may lead to instability, loss of motorcycle control and an accident.

Warning

Accurate wheel balance is necessary for safe, stable handling of the motorcycle. Do not remove or change any wheel balance weights. Incorrect wheel balance may cause instability leading to loss of control and an accident.

When wheel balancing is required, such as after tyre or inner tube replacement, see your authorised Triumph dealer.

Only use self-adhesive weights. Clip on weights may damage the wheel, tyre or inner tube resulting in tyre deflation, loss of motorcycle control and an accident.

Maintenance and Adjustment

Battery

Warning

Under some circumstances, the battery can give off explosive gases; keep sparks, flames and cigarettes away. Provide adequate ventilation when charging or using the battery in an enclosed space.

The battery contains sulphuric acid (battery acid). Contact with skin or eyes may cause severe burns. Wear protective clothing and a face shield.

If battery acid gets on your skin, flush with water immediately.

If battery acid gets in your eyes, flush with water for at least 15 minutes and SEEK MEDICAL ATTENTION IMMEDIATELY.

If battery acid is swallowed, drink large quantities of water and SEEK MEDICAL ATTENTION IMMEDIATELY.

KEEP BATTERY ACID OUT OF THE REACH OF CHILDREN.

Warning

The battery contains harmful materials. Always keep children away from the battery whether or not it is fitted in the motorcycle.

Do not attach jump leads to the battery, touch the battery cables together or reverse the polarity of the cables as any of these actions may cause a spark which would ignite battery gases causing a risk of personal injury.

Battery Removal

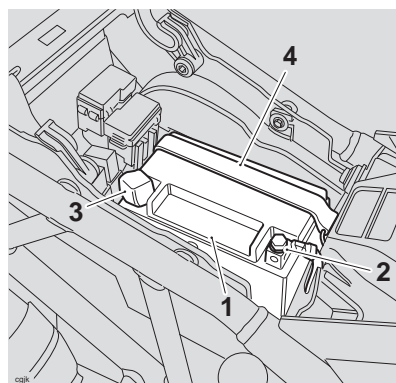

1. **Battery**
2. **Negative (black) terminal**
3. **Positive (red) terminal**
4. **Battery strap**

Remove the rider's seat.

Remove the battery strap.

Disconnect the battery leads, negative (black) lead first.

Take the battery out of the case.

Warning

Ensure that the battery terminals do not touch the motorcycle frame as this may cause a short circuit or spark, which would ignite battery gases causing a risk of personal injury.

Maintenance and Adjustment

Battery Disposal

Should the battery ever require replacement, the original battery must be handed to a recycling agent who will ensure that the dangerous substances from which the battery is manufactured do not pollute the environment.

Battery Maintenance

Clean the battery using a clean, dry cloth. Be sure that the cable connections are clean.

Warning

The battery acid is corrosive and poisonous and will cause damage to unprotected skin. Never swallow battery acid or allow it to come into contact with the skin. To prevent injury, always wear eye and skin protection when handling the battery.

The battery is a sealed type and does not require any maintenance other than checking the Voltage and routine recharging when required, such as during storage.

It is not possible to adjust the battery acid level in the battery; the sealing strip must not be removed.

Battery Discharge

Caution

The charge level in the battery must be maintained to maximise battery life.

Failure to maintain the battery charge level could cause serious internal damage to the battery.

Under normal conditions, the motorcycle charging system will keep the battery fully charged. However, if the motorcycle is unused, the battery will gradually discharge due to a normal process called self discharge; the clock, engine control module (ECM) memory, high ambient temperatures, or the addition of electrical security systems or other electrical accessories will all increase this rate of battery discharge. Disconnecting the battery from the motorcycle during storage will reduce the rate of discharge.

Maintenance and Adjustment

Battery Maintenance During Storage and Infrequent Use of the Motorcycle

During storage or infrequent use of the motorcycle, inspect the battery Voltage weekly using a digital multimeter. Follow the manufacturer's instructions supplied with the meter.

Should the battery Voltage fall below 12.7 Volts, the battery should be charged (see page 107).

Allowing a battery to discharge or leaving it discharged for even a short period of time causes sulphation of the lead plates. Sulphation is a normal part of the chemical reaction inside the battery, however over time the sulphate can crystallise on the plates making recovery difficult or impossible. This permanent damage is not covered by the motorcycle warranty, as it is not due to a manufacturing defect.

Keeping the battery fully charged reduces the likelihood of it freezing in cold conditions. Allowing a battery to freeze will cause serious internal damage to the battery.

Battery Charging

For help with selecting a battery charger, checking the battery Voltage or battery charging, contact your local authorised Triumph dealer.

Warning

The battery gives off explosive gases; keep sparks, flames and cigarettes away. Provide adequate ventilation when charging or using the battery in an enclosed space.

The battery contains sulphuric acid (battery acid). Contact with skin or eyes may cause severe burns. Wear protective clothing and a face shield.

If battery acid gets on your skin, flush with water immediately.

If battery acid gets in your eyes, flush with water for at least 15 minutes and SEEK MEDICAL ATTENTION IMMEDIATELY.

If battery acid is swallowed, drink large quantities of water and SEEK MEDICAL ATTENTION IMMEDIATELY.

KEEP BATTERY ACID OUT OF THE REACH OF CHILDREN.

Maintenance and Adjustment

Caution

Do not use an automotive quick charger as it may overcharge and damage the battery.

Should the battery Voltage fall below 12.7 Volts, the battery should be charged using a Triumph approved battery charger. Always follow the instructions supplied with the battery charger.

For extended periods of storage (beyond two weeks) the battery should be removed from the motorcycle and kept charged using a Triumph approved maintenance charger.

Similarly, should the battery charge fall to a level where it will not start the motorcycle, remove the battery from the motorcycle before charging.

Battery Installation

Warning

Ensure that the battery terminals do not touch the motorcycle frame as this may cause a short circuit or spark, which would ignite battery gases causing a risk of personal injury.

Place the battery in the battery case.

Reconnect the battery, positive (red) lead first.

Apply a light coat of grease to the terminals to prevent corrosion.

Cover the positive terminal with the protective cap.

Refit the battery strap.

Refit the rider's seat.

Fuse Boxes

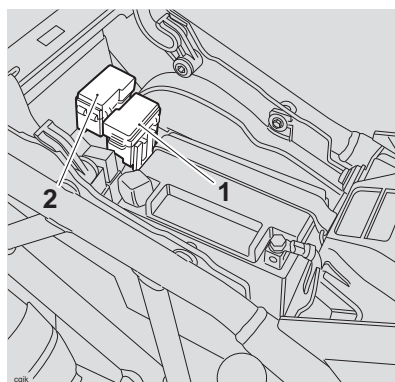

1. Front fuse box
2. Rear fuse box

The fuse boxes are located beneath the rider's seat.

To allow access to the fuse boxes, the rider's seat must be removed.

Warning

Always replace blown fuses with new ones of the correct rating (as specified on the fuse box cover) and never use a fuse of higher rating. Use of an incorrect fuse could lead to an electrical problem, resulting in motorcycle damage, loss of motorcycle control and an accident.

Maintenance and Adjustment

Fuse Identification

A blown fuse is indicated when all of the systems protected by that fuse become inoperative. When checking for a blown fuse, use the tables to establish which fuse has blown.

The fuse identification numbers listed in the tables correspond with those printed on the fuse box covers, as shown below. Spare fuses are located at right angles to the main fuses and should be replaced if used.

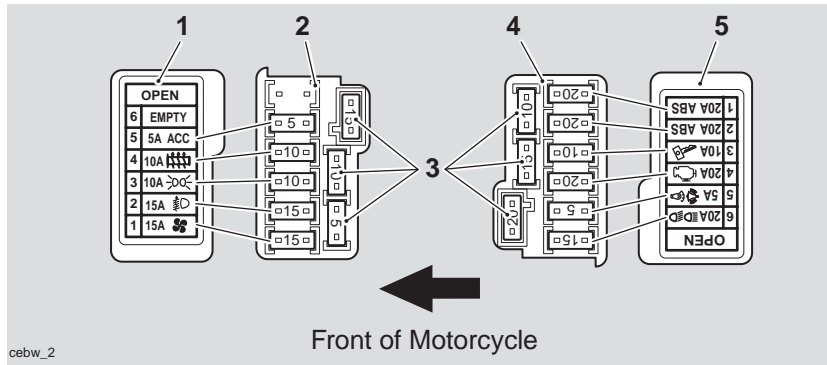

1. Front fuse box cover
2. Front fuse box
3. Spare fuses

4. Rear fuse box
5. Rear fuse box cover

Front fuse box

Circuit Protected	Position	Rating (Amps)
Cooling fan	1	15
Accessory lights	2	5
Auxiliary lighting	3	10
Heated Grips	4	10
Accessory sockets	5	15
Not used	6	-

Rear fuse box

Circuit Protected	Position	Rating (Amps)
ABS	1	20
ABS	2	20
Alarm, instruments, ECM	3	10
Engine management	4	20
Alarm, diagnostic connector, instruments	5	5
Dip and main beam headlights, starter relay	6	20

Note:

- The starter solenoid has an additional 30 Amp fuse, attached

directly to the solenoid, beneath the rider's seat.

Maintenance and Adjustment

Headlights

Headlights

Warning

Adjust road speed to suit the visibility and weather conditions in which the motorcycle is being operated.

Ensure that the beams are adjusted to illuminate the road surface sufficiently far ahead without dazzling oncoming traffic. An incorrectly adjusted headlight may impair visibility causing an accident.

Warning

Never attempt to adjust a headlight beam when the motorcycle is in motion.

Any attempt to adjust a headlight beam when the motorcycle is in motion may result in loss of control and an accident.

Caution

Do not cover the headlight or lens with any item likely to obstruct air flow to, or prevent heat escaping from, the headlight lens.

Covering the headlight lens during operation with items of clothing, luggage, adhesive tape, devices intended to alter or adjust the headlight beam or non genuine headlight lens covers will cause the headlight lens to overheat and distort, causing irreparable damage to the headlight assembly.

Damage caused by overheating is not considered a manufacturing defect and will not be covered under warranty.

If the headlight must be covered during use – such as taping of the headlight lens required during closed-course conditions – the headlight must be disconnected.

Maintenance and Adjustment

Headlight Adjustment

Each headlight can be adjusted by means of vertical and horizontal adjustment screws located on the rear of each headlight. In addition, the headlight is equipped with an easily accessible adjuster to allow the vertical adjustment to be corrected when the motorcycle is fully loaded.

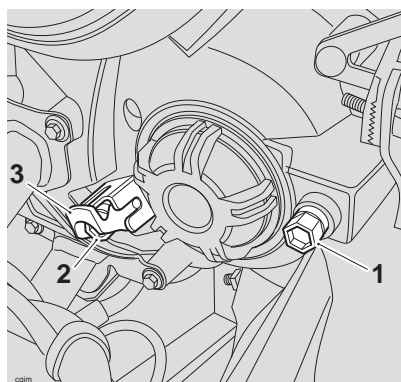

1. **Horizontal (LEFT - RIGHT) adjustment screw**
2. **Vertical (UP - DOWN) adjustment screw**
3. **Headlight adjuster lever for loaded conditions**

Switch the headlight dipped beam on.

Turn the vertical (UP - DOWN) adjustment screw on the headlight clockwise to raise the beam or anti-clockwise to lower the beam.

Turn the horizontal (LEFT - RIGHT) adjustment screw clockwise to move the beam to the right or anti-clockwise to move the beam to the left.

Switch the headlights off when the beam settings are satisfactory.

Headlight Adjustment Lever for Loaded Conditions

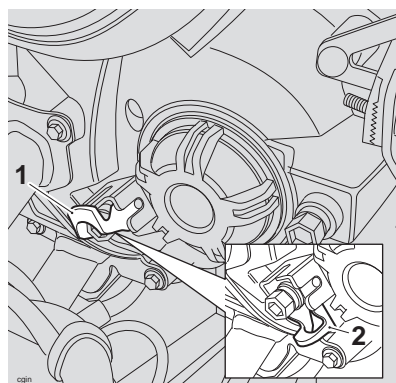

1. **Headlight adjuster lever (unloaded position)**
2. **Headlight adjuster lever (loaded position)**

For normal (unloaded) conditions the headlight adjuster lever should be set in the horizontal position (1).

For loaded conditions rotate the headlight adjuster downwards until it stops (2). This will lower the headlight beams by approximately 2°.

Maintenance and Adjustment

Headlight Bulb Replacement

Caution

The use of non-approved headlight bulbs may result in damage to the headlight lens. Use a genuine Triumph supplied headlight bulb as specified in the Triumph Parts Catalogue.

Always have replacement headlight bulbs installed by an authorised Triumph dealer.

It is not necessary to remove the headlight when bulb replacement becomes necessary.

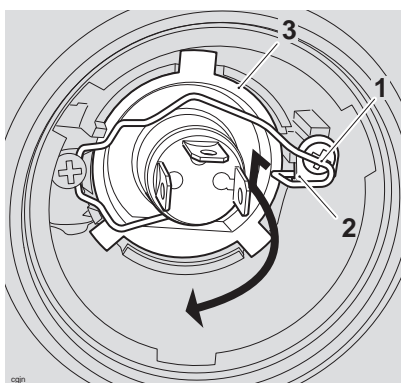

1. Bulb retainer (right hand shown)
2. Bulb retainer hook
3. Bulb

Warning

The bulbs become hot during use. Always allow sufficient time for the bulb to cool before handling. Avoid touching the glass part of the bulb. If the glass is touched or gets dirty, clean with alcohol before reuse.

To replace a bulb:

Remove the rider's seat.

Disconnect the battery, negative (black) lead first.

Remove the bulb cover from the bulb to be replaced by rotating it anti-clockwise.

Disconnect the multi-plug from the bulb.

Detach the bulb retainer from the hook on the headlight assembly and rotate it away from the bulb as shown.

Remove the bulb from the bulb retainer.

Installation is the reverse of the removal procedure.

Position Lamp Bulb Replacement

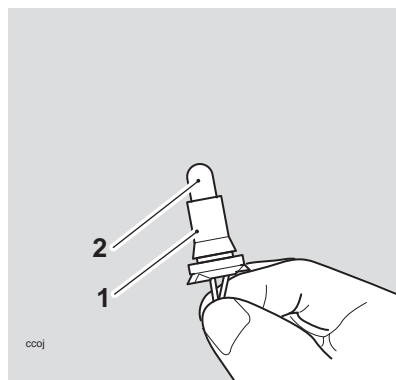

1. Bulb holder
2. Position lamp bulb

The position lamp is fitted to the centre of the headlight. To replace the bulb, remove the four fixings and remove the headlight surround, detach the rubber retainer from the headlight and pull out the bulb.

Installation is the reverse of the removal procedure.

Maintenance and Adjustment

Rear Light/Licence Plate Light

Rear Light/Licence Plate Light Replacement

The rear light unit is a sealed, maintenance free LED unit. The licence plate light is integral to the rear light unit.

Direction Indicator Lights

Bulb Replacement

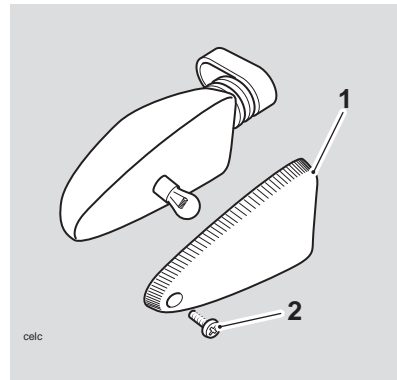

1. Indicator lens
2. Securing screw

The lens on each indicator light is held in place by a securing screw located in the lens of the light.

Release the screw and remove the lens to gain access to the bulb for replacement.

Maintenance and Adjustment

Bank Angle Indicators

Warning

Use of a motorcycle with bank angle indicators worn beyond the maximum limit (as described below) will allow the motorcycle to be banked to an unsafe angle.

Banking to an unsafe angle may cause instability, loss of motorcycle control and an accident causing injury or death.

Bank angle indicators are located on the riders footrests.

Regularly check the bank angle indicators for wear.

Use of a motorcycle with bank angle indicators worn beyond the maximum limit when 10 mm of the bank indicator remains (Tiger 800) or when 5 mm of the bank indicator remains (Tiger 800XC) will allow the motorcycle to be banked to an unsafe angle.

Banking to an unsafe angle may cause instability, loss of motorcycle control and an accident.

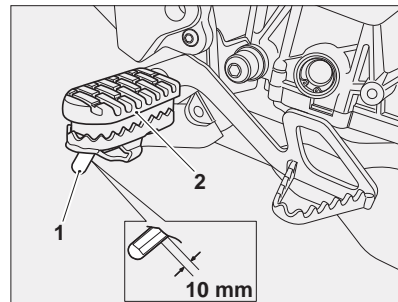

1. Bank angle indicator (Tiger 800)
2. Footrest

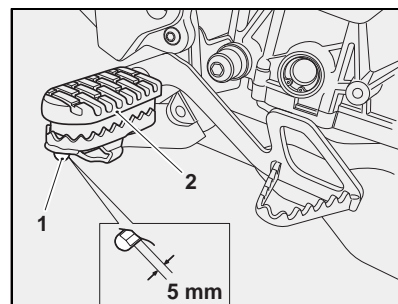

1. Bank angle indicator (Tiger 800XC)
2. Footrest

Maintenance and Adjustment

Cleaning

Frequent, regular cleaning is an essential part of the maintenance of your motorcycle. If regularly cleaned, the appearance will be preserved for many years. Cleaning with cold water containing an automotive cleaner is essential at all times but particularly so after exposure to sea breezes, sea water, dusty or muddy roads and in winter when roads are treated for ice and snow. Do not use household detergent, as the use of such products will lead to premature corrosion.

Although, under the terms of your motorcycle warranty, cover is provided against the corrosion of certain items, the owner is expected to observe this reasonable advice which will safeguard against corrosion and enhance the appearance of the motorcycle.

Care of Matt Paintwork

Matt paintwork requires no greater care than that already recommended for high gloss paintwork.

- Do not use any polish or wax on components
- Do not try and polish out scratches.

Preparation for Washing

Before washing, precautions must be taken to keep water off the following places.

Rear opening of the exhausts: Cover with a plastic bag secured with rubber bands.

Clutch and brake levers, switch housings on the handlebar: Cover with plastic bags.

Ignition switch and steering lock: Cover the keyhole with tape.

Remove any items of jewellery such as rings, watches, zips or belt buckles, which may scratch or otherwise damage painted or polished surfaces.

Use separate cleaning sponges or cleaning cloths for washing painted/polished surfaces and chassis areas. Chassis areas (such as wheels and under mudguards) will be exposed to more abrasive road grime and dust, which may then scratch painted or polished surfaces, if the same sponge or cleaning cloths are used.

Maintenance and Adjustment

Where to be Careful

Avoid spraying water with any great force near the following places:

- Instruments
- Brake cylinders and brake calipers
- Under the fuel tank
- Headstock bearings
- Air intake duct under the rider's seat.

Caution

Any water sprayed around the air intake duct could enter the airbox and engine, causing damage to both items.

Caution

Use of high-pressure spray washers is not recommended. When using pressure washers, water may be forced into bearings and other components causing premature wear from corrosion and loss of lubrication.

Note:

- **Use of soaps that are highly alkaline will leave a residue on painted surfaces, and may also cause water spotting. Always use a low alkaline soap to aid the cleaning process.**

After Washing

Remove the plastic bags and tape, and clear the air intakes.

Lubricate the pivots, bolts and nuts.

Test the brakes before motorcycle operation.

Start the engine and run it for 5 minutes. Ensure adequate ventilation for the exhaust fumes.

Use a dry cloth to absorb water residue. Do not allow water to stand on the machine as this will lead to corrosion.

Warning

Never wax or lubricate the brake discs. Loss of braking power and an accident could result. Clean the disc with a proprietary brand of oil-free brake disc cleaner.

Seat Care

Caution

Use of chemicals or high-pressure spray washers is not recommended for cleaning the seat. Using chemicals or pressure washers may damage the seat cover.

To help maintain its appearance, clean the seat using a sponge or cleaning cloth with soap and water.

Maintenance and Adjustment

Unpainted Aluminium Items

Items such as brake and clutch levers, wheels, engine covers, top and bottom yokes on some models must be correctly cleaned to preserve their appearance. Please contact your dealer if you are unsure which components on your motorcycle are unpainted aluminium parts.

Use a proprietary brand of aluminium cleaner which does not contain abrasive or caustic elements.

Clean aluminium items regularly, in particular after use in inclement weather, where the components must be hand washed and dried each time the machine is used.

Warranty claims due to inadequate maintenance will not be allowed.

Cleaning of the Exhaust System

All parts of the exhaust system of your motorcycle must be cleaned regularly to avoid a deterioration of its appearance.

Note:

- **The exhaust system must be cool before washing to prevent water spotting.**

Windscreen Cleaning

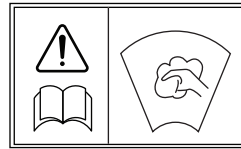

Clean the windscreen with a solution of mild soap or detergent and lukewarm water. After cleaning, rinse well and then dry with a soft, lint free cloth.

Caution

Products such as window cleaning fluids, insect remover, rain repellent, scouring compounds, petrol or strong solvents such as alcohol, acetone, carbon tetrachloride, etc. will damage the windscreen. Never allow these products to contact the screen.

If the transparency of the windscreen is reduced by scratches or oxidation which cannot be removed, the windscreen must be replaced.

Maintenance and Adjustment

Warning

Never attempt to clean the windscreen while the motorcycle is in motion as releasing the handlebars may cause loss of vehicle control and an accident.

Operation of the motorcycle with a damaged or scratched windscreen will reduce the rider's forward vision. Any such reduction in forward vision is dangerous and may lead to an accident causing injury or death.

Caution

Corrosive chemicals such as battery acid will damage the windscreen. Never allow corrosive chemicals to contact the windscreen.

Washing

Prepare a mixture of cold water and mild automotive cleaner. Do not use a highly alkaline soap as commonly found at commercial car washes because it leaves a residue.

Wash the exhaust system with a soft cloth. Do not use an abrasive scouring pad or steel wool. They will damage the finish.

Rinse the exhaust system thoroughly.

Ensure no soap or water enters the mufflers.

Drying

Dry the exhaust system as far as possible with a soft cloth. Do not run the engine to dry the system or spotting will occur.

Protecting

When the exhaust system is dry, rub 'Motorex 645 Clean and Protect' into the surface.

Caution

The use of abrasive cleaners and polishes will damage the system and must not be used.

It is recommended that regular protection be applied to the system as this will both protect and enhance the system's appearance.

Maintenance and Adjustment

Care of Leather Products

We recommend that you periodically clean your leather products with a damp cloth and allow them to dry naturally at room temperature. This will maintain the appearance of the leather and ensure the long life of your product.

Your Triumph leather product is a natural product and lack of care can result in damage and permanent wear. Follow these simple instructions and give your leather product the respect it deserves:

- Do not use household cleaning products, bleach, detergents containing bleach or any kind of solvent to clean your leather product.
- Do not immerse your leather product in water.
- Avoid direct heat from fires and radiators which can dry out and distort the leather.
- Do not leave your leather product in direct sunlight for prolonged periods of time.
- Do not dry your leather product by applying direct heat to it at any time.
- If your leather product does get wet, absorb any excess water with a soft clean cloth then leave the product to dry naturally at room temperature.
- Avoid exposure of your leather product to high levels of salt, for example sea/salt water or road surfaces that have been treated during the winter for ice and snow.
- If exposure to salt is unavoidable, clean your leather product immediately after each exposure using a damp cloth then leave the product to dry naturally at room temperature.
- Gently clean any minor marks with a damp cloth then leave the product to dry naturally at room temperature.
- Place your leather product in a fabric bag or cardboard box to protect it when in storage. Do not use a plastic bag.

Maintenance and Adjustment

This page intentionally left blank

STORAGE

Preparation for Storage

Clean and dry the entire vehicle thoroughly.

Fill the fuel tank with the correct grade of unleaded fuel and add a fuel stabiliser (if available), following the fuel stabiliser manufacturer's instructions.

 **Warning**

Petrol is extremely flammable and can be explosive under certain conditions. Turn the ignition switch off. Do not smoke. Make sure the area is well ventilated and free from any source of flame or sparks; this includes any appliance with a pilot light.

Remove the spark plug from each cylinder and put several drops (5 ml) of engine oil into each cylinder. Cover the spark plug holes with a piece of cloth or rag. With the engine stop switch in the RUN position, push the starter button for a few seconds to coat the cylinder walls with oil. Install the spark plugs, tightening to **12 Nm**.

Change the engine oil and filter (see page 78).

Check and if necessary correct the tyre pressures (see page 127).

Set the motorcycle on a stand so that both wheels are raised off the ground. (If this cannot be done, put boards under the front and rear wheels to keep dampness away from the tyres.)

Spray rust inhibiting oil (there are a host of products on the market and your dealer will be able to offer you local advice) on all unpainted metal surfaces to prevent rusting. Prevent oil from getting on rubber parts, brake discs or in the brake calipers.

Lubricate and if necessary adjust the drive chain (see page 87).

Make sure the cooling system is filled with a 50% mixture of coolant (noting that HD4X Hybrid OAT coolant, as supplied by Triumph, is pre-mixed and requires no dilution) and distilled water solution (see page 80).

Remove the battery, and store it where it will not be exposed to direct sunlight, moisture, or freezing temperatures. During storage it should be given a slow charge (one ampere or less) about once every two weeks (see page 105).

Store the motorcycle in a cool, dry area, away from sunlight, and with a minimum daily temperature variation.

Put a suitable porous cover over the motorcycle to keep dust and dirt from collecting on it. Avoid using plastic or similar non-breathable, coated materials that restrict air flow and allow heat and moisture to accumulate.

Storage

Preparation after Storage

Install the battery (if removed) (see page 108).

If the motorcycle has been stored for more than four months, change the engine oil (see page 78).

Check all the points listed in the Daily Safety Checks section.

Before starting the engine, remove the spark plugs from each cylinder.

Put the side stand down.

Crank the engine on the starter motor several times until the oil pressure light goes out.

Refit the spark plugs, tightening to **12 Nm**, and start the engine.

Check and if necessary correct the tyre pressures (see page 127).

Clean the entire vehicle thoroughly.

Check the brakes for correct operation.

Test ride the motorcycle at low speeds.

Specifications

SPECIFICATIONS

	Tiger 800	Tiger 800XC
Dimensions		
Overall Length	2,215 mm (87.2 in)	2,215 mm (87.2 in)
Overall Width	795 mm (31.3 in)	865 mm (34.1 in)
Overall Height	1,350 mm (53.1 in)	1,390 mm (54.7 in)
Wheelbase	1,530 mm (60.2 in)	1,545 mm (60.8 in)
Seat Height	813 mm (32.0 in)	847 mm (33.3 in)
Weights		
Wet Weight	210 kg (463 lb)	215 kg (474 lb)
Maximum Payload	225 kg (496 lb)	223 kg (492 lb)
Engine		
Type	In-line 3 cylinder	In-line 3 cylinder
Displacement	800 cc	800 cc
Bore x Stroke	74 x 61.94 mm	74 x 61.94 mm
Compression Ratio	11.1:1	11.1:1
Cylinder Numbering	Left to Right	Left to Right
Cylinder Sequence	1 at left	1 at left
Firing Order	1-2-3	1-2-3
Starting System	Electric Starter	Electric Starter

Specifications

	Tiger 800	Tiger 800XC
Performance		
Maximum Power (95/1/EC)	70 kW at 9,300 rpm (95 PS/94 bhp)	70 kW at 9,300 rpm (95 PS/94 bhp)
Maximum Torque	79 Nm at 7,850 rpm (58 lb-ft)	79 Nm at 7,850 rpm (58 lb-ft)
Lubrication		
Lubrication	Pressure Lubrication (wet sump)	Pressure Lubrication (wet sump)
Engine Oil Capacities		
Dry Fill	4.1 litres	4.1 litres
Oil/Filter Change	3.6 litres	3.6 litres
Oil Change Only	3.4 litres	3.4 litres
Cooling		
Coolant Type	Triumph HD4X Hybrid OAT coolant	Triumph HD4X Hybrid OAT coolant
Water/Anti-freeze ratio	50/50 (premixed as supplied by Triumph)	50/50 (premixed as supplied by Triumph)
Coolant Capacity	2.4 litres	2.4 litres
Thermostat Opens (nominal)	71 °C	71 °C

Specifications

	Tiger 800	Tiger 800XC
Fuel System		
Type.....	Electronic Fuel Injection	Electronic Fuel Injection
Injectors.....	Solenoid Operated	Solenoid Operated
Fuel Pump.....	Submerged Electric	Submerged Electric
Fuel Pressure (nominal).....	3 bar	3 bar
Fuel		
Type.....	91 RON unleaded	91 RON unleaded
Tank Capacity (motorcycle upright).....	19.0 litres	19.0 litres
Ignition		
Ignition System.....	Digital Inductive	Digital Inductive
Electronic Rev Limiter (r/min).....	10,000 (r/min)	10,000 (r/min)
Spark Plug.....	NGK CR9EK	NGK CR9EK
Spark Plug Gap.....	0.7 mm	0.7 mm
Gap Tolerance.....	+0.05/-0.1 mm	+0.05/-0.1 mm

Specifications

	Tiger 800	Tiger 800XC
Transmission		
Transmission Type.....	6 Speed, Constant Mesh	6 Speed, Constant Mesh
Clutch Type.....	Wet, Multi-Plate	Wet, Multi-Plate
Final Drive Chain (All markets except Brazil).....	DID O-ring, 122 link	DID O-ring, 124 link
Final Drive Chain (Brazil only).....	DID O-ring, 122 link	DID O-ring, 122 link
Primary Drive Ratio.....	1.667:1 (85/51)	1.667:1 (85/51)
Gear Ratios:		
Final Drive Ratio.....	3.125:1 (50/16)	3.125:1 (50/16)
1 st	2.313:1 (37/16)	2.313:1 (37/16)
2 nd	1.857:1 (39/21)	1.857:1 (39/21)
3 rd	1.500:1 (36/24)	1.500:1 (36/24)
4 th	1.285:1 (27/21)	1.285:1 (27/21)
5 th	1.136:1 (25/22)	1.136:1 (25/22)
6 th	1.043:1 (24/23)	1.043:1 (24/23)

Specifications

	Tiger 800	Tiger 800XC
Tyres		
Triumph Recommended Tyre Sizes:		
Front Size	100/90 - 19 M/C 57V	90/90 - 21 M/C 54V
Rear Size	150/70 R 17 M/C 69V	150/70 R 17 M/C 69V
Front tyre size 110/80 R 19 M/C 59V listed in the options below, may be used in markets where the recommended size is not available.		
On-Road Tyre Pressures (Cold):		
Front	2.5 bar (36 lb/in ²)	2.5 bar (36 lb/in ²)
Rear	2.9 bar (42 lb/in ²)	2.9 bar (42 lb/in ²)

 **Warning**

Use the recommended tyres **ONLY** in the combinations given. Do not mix tyres from different manufacturers or mix different specification tyres from the same manufacturers as this may result in loss of motorcycle control and an accident.

Specifications

	Tiger 800	Tiger 800XC
Approved Road Tyres:		
Option 1, Front	Pirelli Scorpion Trail Standard specification	Pirelli Scorpion Trail Standard specification
Option 1, Rear	Pirelli Scorpion Trail Standard specification	Pirelli Scorpion Trail Standard specification
Option 2, Front	Metzeler Tourance EXP Standard specification	Bridgestone Battle Wing BW501 G
Option 2, Rear	Metzeler Tourance EXP Standard specification	Bridgestone Battle Wing BW502

 **Warning**

The use of dual purpose tyres will result in reduced motorcycle stability. Always operate a motorcycle equipped with dual purpose tyres at reduced speeds. The permissible maximum speed (as shown below) must be indicated by a sticker, positioned so that it is clearly visible to the rider. Operation of the motorcycle above the permissible maximum speed may result in loss of motorcycle control and an accident.

Specifications

Tiger 800XC Only

Approved Dual Purpose Tyres (for off-road and on-road use)*‡

Option 2, Front	Metzeler MCE Karoo 2 (T)
Option 2, Rear	Metzeler MCE Karoo (T)

*The permissible maximum speed for dual purpose tyres is 60 mph (96 km/h).

‡Dual purpose tyres (approved by Triumph for off road and on road use in some countries only).

Warning

Tyre pressures which have been reduced for off-road riding will impair on-road stability. Always ensure the tyre pressures are set as described on page 127 for on-road use. Operation of the motorcycle with incorrect tyre pressures may cause loss of motorcycle control leading to an accident.

Specifications

Tiger 800XC Only

Off-Road Tyre Pressures (Cold):

Front	1.5 bar (22 lb/in ²)
Rear	1.5 bar (22 lb/in ²)

Tiger 800

Tiger 800XC

Electrical Equipment

Battery Type	YTX-16BS	YTX-16BS
Battery Rating	12 Volt, 14 Ah	12 Volt, 14 Ah
Alternator	12 Volt, 34 Amp at 4,000 rpm	12 Volt, 34 Amp at 4,000 rpm
Headlight	2 x 12 Volt, 55/60 watt, H4 Halogen	2 x 12 Volt, 55/60 watt, H4 Halogen
Tail/Brake Light	LED	LED
Directional Indicator Lights	12 Volt, 10 watt	12 Volt, 10 watt

Frame

Rake	23.9°	24.3°
Trail	92.4 mm	95.3 mm

Specifications

All Models

Tightening Torques

Oil Filter	10 Nm
Oil Drain Plug	25 Nm
Spark Plug	12 Nm
Rear Wheel Spindle	110 Nm
Chain Adjuster Lock Nut	15 Nm

Fluids and Lubricants

Engine Oil	Semi or fully synthetic 10W/40 or 10W/50 motorcycle engine oil which meets specification API SH (or higher) and JASO MA, such as Castrol Power 1 Racing 4T 10W-40 (fully synthetic) engine oil, sold as Castrol Power RS Racing 4T 10W-40 (fully synthetic) in some countries.
Brake and Clutch Fluid	DOT 4 Brake and Clutch Fluid
Coolant	Triumph HD4X Hybrid OAT coolant
Bearings and Pivots	Grease to NLGI 2 specification
Drive Chain	Chain spray suitable for O-ring chains

Specifications

This page intentionally left blank

INDEX

A

Accessories 67

B

Bank Angle Indicators..... 11, 114

Battery..... 105

 Charging 107

 Disposal 106

 Installation 108

 Maintenance 106

 Removal..... 105

Brakes 91

 Brake and Clutch Lever Adjusters .. 39

 Braking..... 59

 Disc Brake Fluid..... 92

 Light Switches 94

 Pad Wear Compensation 92

 Wear Inspection..... 91

C

Cleaning 115

 After Washing 116

 Care of Leather Products 119

 Care of Matt Paintwork..... 115

 Drying 118

 Exhaust System..... 117

 Preparation..... 115

 Protecting..... 118

 Unpainted Aluminium Items..... 117

 Washing..... 118

 Where to be Careful 116

Clutch 86

 Adjustment 86

 Inspection..... 86

Considerations for High-Speed

 Operation 63

Cooling System..... 80

 Change..... 82

 Coolant Level Inspection 81

 Corrosion Inhibitors..... 80

 Level Adjustment..... 82

D

Dimensions 123

Direction Indicator Lights 113

Drive Chain 87

 Lubrication 87

 Movement Adjustment 88

 Movement Inspection 88

 Wear Inspection..... 89

E

Electrical Equipment 130

Engine

 Serial Number 19

 Specifications 123

 To Start the Engine 56

 To Stop the Engine 56

Engine Oil 77

 Disposal of Oil and Filters 79

 Grade and Specification..... 79

 Oil and Oil Filter Change 78

 Oil Level Inspection 77

F

Fluids and Lubricants 131

Frame..... 130

Front Suspension..... 96

 Fork Inspection..... 96

Fuel 125

Fuel Requirement 44

 Filling the Fuel Tank..... 45

 Fuel Grade 44

 Fuel Tank Cap 45

Fuel System..... 125

Fuse Box 108

Index

G

- Gears
- Changing Gears 58

H

- Headlights 110
 - Adjustment 111
 - Bulb Replacement 112

I

- Ignition 125
 - Key 37
 - Switch/Steering Lock 38
- Immobiliser and Tyre Pressure Monitoring System 3
- Instrument Panel
 - Change Units 27
 - Clock Adjustment 26
 - Speedometer 24
 - Tachometer 24
 - Trip Meter 25

L

- Left Handlebar Switches 41
 - Direction Indicator Switch 42
 - Headlight Dip Switch 41
 - Horn Button 42
 - Pass Button 42
- Licence Plate Light 113
- Lubrication 124

M

- Maintenance 2

N

- Noise Control System 2

O

- Off-road Use 2
- Owner's Handbook 3

P

- Parts Identification 14
- Performance 124

R

- Rear Light 113
- Rear Seat 48
- Rear Suspension
 - Rebound Damping 98
 - Spring Pre-Load 97
- Rear Suspension Adjustment 96
- Rear suspension setting chart -
 - Tiger 800 96
 - Rear suspension setting chart -
 - Tiger 800XC 96
- Rider's Seat 49
- Right Handlebar Switches 40
 - Engine Stop Switch 40
 - Starter Button 41
- Running-In 52

S

- Safety 6
 - Daily Checks 53
 - Fuel and Exhaust Fumes 7
 - Handlebars and Footrests 10
 - Helmet and Clothing 7
 - Maintenance/Equipment 9
 - Motorcycle 6
 - Parking 8
 - Parts and Accessories 8
 - Riding 9
- Seat Lock 47
- Stand 46
 - Side Stand 46
- Steering/Wheel Bearings 94
 - Inspection 95
- Storage
 - Preparation after Storage 122
 - Preparation for Storage 121

Index

T		V	
Talk to Triumph	4	Vehicle Identification Number	19
Throttle Control	83	W	
Tightening Torques	131	Warning Lights	33
Tool Kit	46	Warnings	
Transmission	126	Warning Label Locations	12
Tyres	2, 98	Warning Labels	2
Minimum Recommended		Warnings, Cautions and Notes	1
Tread Depth	101	Weights	123
Tyre Inflation Pressures	100	Windscreen Cleaning	117
Tyre Replacement	102		
Tyre Wear	101		

Index

This page intentionally left blank