

Audi R8

Owner's Manual

Audi R8 englisch 03.07

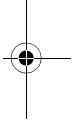

© 2007 AUDI AG

AUDI AG works continuously to develop and further improve all models. You will appreciate that we must therefore reserve the right to alter any part of the vehicle and its equipment or technical specifications at any time. No legal commitment can therefore be implied by the information, illustrations or descriptions in this Manual.

No part of this Owner's Manual translated without the written consent of Audi AG.
under the laws of copyright.
Subject to alteration and amendment.
Date of publication: 02.02.2007



For the sake of the environment
This paper was bleached without the use of chlorine.

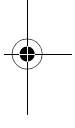

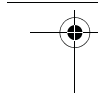

Foreword

Thank you for choosing the Audi R8.

The new Audi R8 combines the latest technology with numerous features for your comfort and convenience. To help you get the best out of these features in everyday use, we recommend that you read this Manual carefully.

As well as information on how to use the controls and equipment, the Owner's Manual contains important notes on care and maintenance. These are relevant to your safety and will help preserve your car's value.

In addition to this Owner's Manual, the Service Wallet also includes the Operating Manual for your infotainment system and the Service Schedule. The Service Schedule contains important information on Audi service requirements and lists the vehicle's fuel consumption figures. We recommend that you keep the Service Wallet in the car at all times.

Our Audi R8 dealers are comprehensively trained and qualified to ensure that you receive the highest level of quality, comfort and convenience. Should you have any further questions regarding your car or if you suspect that your owner's literature is not complete, please contact your Audi R8 dealer or importer. They are always glad to answer your queries and note any suggestions you may have.

We wish you safe and enjoyable motoring with your Audi R8.

AUDI AG

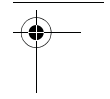
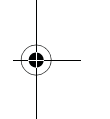
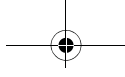
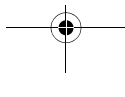

Contents

Notes on this Owner's Manual	5		
			
Controls	7		
Controls and displays	9		
Overview	9		
Instrumenting and warning/indicator lamps	10		
Instruments	10		
Warning and indicator lamps	15		
Driver information system	20		
Introduction	20		
Service interval display	21		
On-board computer	22		
Menus	24		
Lap timer	27		
Speed warning function	31		
Notes and symbols	33		
Doors and windows	40		
Remote control keys	40		
Central locking system	42		
Luggage lid	47		
Anti-theft alarm system	48		
Electric windows	50		
Lights and vision	52		
Lights	52		
Interior lights	57		
Clear vision	58		
Windscreen wipers	59		
Rear-view mirrors	63		
Digital compass	65		
Seats and storage	67		
Manually adjustable front seats ..	67		
Electrically adjustable front seats ..	68		
Bucket seats	70		
Head restraints	71		
Cup holders	72		
Ashtray	72		
Cigarette lighter and electrical socket	72		
Storage compartments	73		
Heating and cooling	75		
Air conditioner	75		
Rear window heating 	79		
Seat heating	80		
Driving	81		
Steering	81		
Ignition lock	81		
Starting the engine	82		
Switching off the engine	83		
Handbrake	83		
Parking aid	85		
Cruise control system	86		
Audi magnetic ride	88		
Automatic gearbox	90		
Description	90		
Manual mode	91		
Automatic mode	92		
Kick-down feature	92		
Launch control programme	93		
Steering wheel with paddle levers ..	93		
Backup programme	94		
HomeLink	95		
Universal transmitter	95		
			
Safety	101		
Safe driving	102		
General notes	102		
Correct sitting positions	104		
Pedal area	107		
Stowing luggage safely	108		
Seat belts	109		
Why is it so important to use seat belts?	109		
Forces acting in a collision	110		
How to wear seat belts properly ..	112		
Belt tensioners	114		
Airbag system	115		
Description of airbag system	115		
Front airbags	116		
Side airbags	118		
Deactivating the airbags	120		

Child safety 122
 Points to remember if children are travelling in the car 122
 Child safety seats 123
 Fitting child safety seats 126

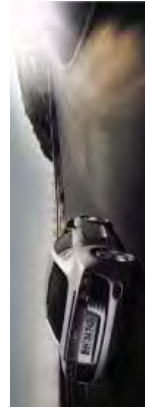

Driving tips 131
 Intelligent technology 132
 Electronic stabilisation program (ESP) 132
 Rear spoiler 134
 Brakes 134
 Power steering 136
 Four-wheel drive (quattro®) 136
 Dry sump lubrication system 137
Your vehicle and the environment 138
 Running in 138
 Emission control systems 138
 Driving abroad 139
 Sporty driving 139
 Environmental compatibility 139



General maintenance .. 143
 Care of vehicle and cleaning ... 144
 General notes 144
 Care of exterior 144
 Care of interior 147
 Fuel and filling the tank 152
 Petrol 152
 Filling the tank 152
Checking and topping up fluids 155
 Engine lid 155
 Engine oil 157
 Cooling system 159
 Brake fluid 161
 Battery 162
 Windscreen washer 164
 Wheels and tyres 166
 Wheels 166
 Tyre pressure monitoring system 172
Accessories and modifications to the vehicle 174
 Accessories, replacement parts and repairs 174
 Modifications 174
 Radio transmitters and business equipment 175



Self-help 177
 Self-help 178
 Breakdown kit 178
 Repairing a tyre 178
 Changing a wheel 182
 Jump-starting 185
 Tow-starting and towing away ... 187
Fuses and bulbs 190
 Fuses 190
 Bulbs 193



Technical data 195
 General notes 196
 Notes 196
 Vehicle identification data 196
Performance, weights and dimensions 198
 R8 4.2 quattro 198
 Dimensions 198
 Capacities 199

4 Contents



Index 201

Notes on this Owner's Manual

This Owner's Manual contains important information, tips, suggestions and warnings.

Please ensure that this Owner's Manual is always kept in the vehicle. It should always be available to anyone else driving the vehicle, i.e. anyone renting, borrowing or buying the vehicle from you.

This manual describes **the equipment available for the vehicle at the time of going to print**. Some of the equipment described here will not be available until a later date, or may only be available in certain markets.

Some sections of this Owner's Manual do not apply to all vehicles. If this is the case, a text at the start of the section indicates which vehicles it applies to, e.g. "Applies to vehicles: with R tronic". This optional equipment is also marked with an asterisk "**".

Illustrations are intended as a general guide, and may vary from the equipment fitted in your vehicle in some details.

At the beginning of this Owner's Manual, you will find a **table of contents** showing all the items described in this manual in the order in which they appear. An **alphabetical index** is included at the end of the Owner's Manual.

All references to **positions** such as "left", "right", "front" or "rear" are given as seen facing in the direction of travel.

* optional equipment

- ▶ The section is continued on the following page.
- Denotes the **end of a section**.
- ® Registered trademarks are marked ®. However, the absence of this symbol does not constitute a waiver of the rights concerning any proprietary name.

⇒ ⚠ Refers to a "WARNING" within the same section. If the WARNING symbol is followed by a page number the warning text referred to is included in a different section.



WARNING

Texts with this symbol contain safety information. They warn you of serious dangers, possibly involving accident or injury.



Caution

Texts with this symbol draw your attention to a possible risk of damage to your vehicle.



For the sake of the environment

Texts with this symbol refer to points relevant to the protection of the environment.



Note

Texts with this symbol contain additional information of a more general nature. ■

Controls

Safety

Driving tips

General maintenance

Self-help

Technical data





8 Controls and displays

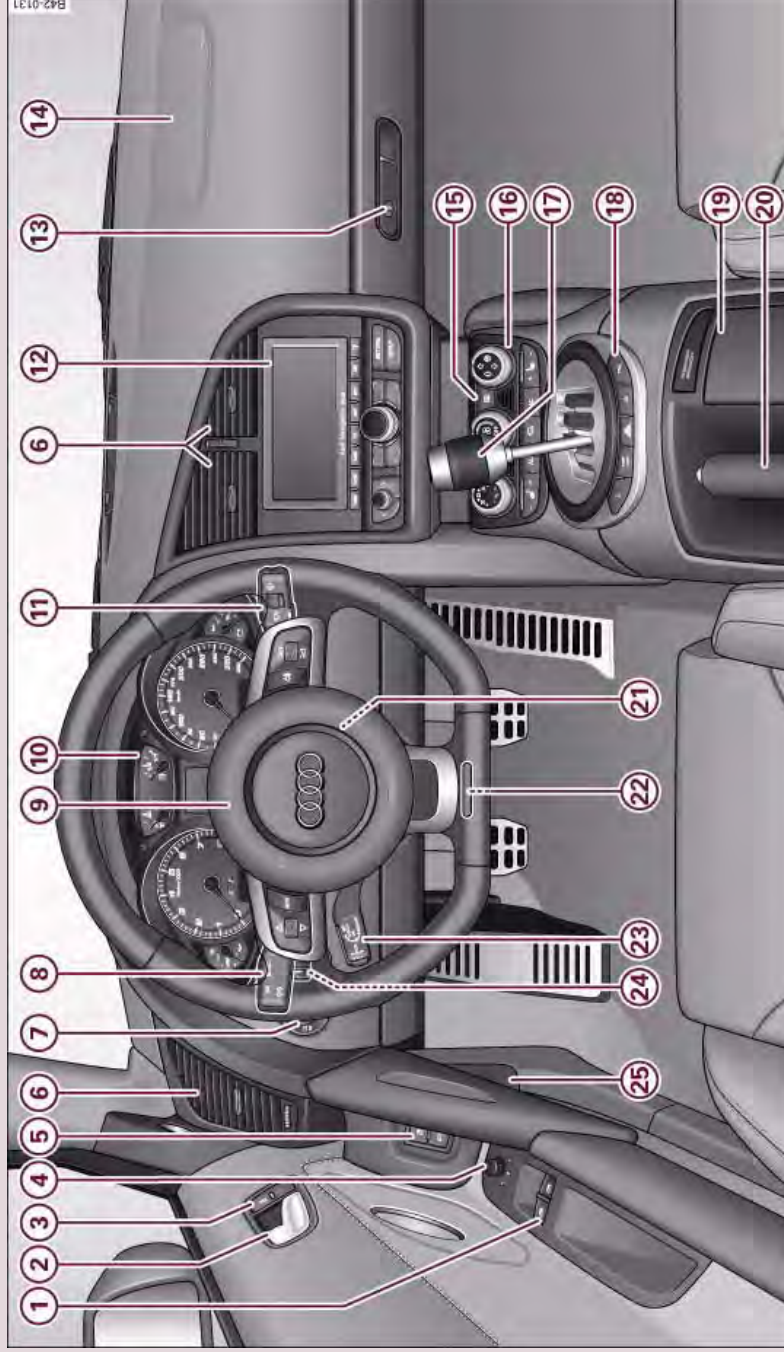

Fig. 1 Some of the items of equipment listed in this section are only fitted on certain models or are optional extras.

Controls and displays

Overview

① Electric windows	50
② Door handle	
③ Central locking switch	45
④ Electric adjuster for exterior mirrors	64
⑤ Switches for	
– Unlocking the luggage lid	47
– Unlocking the fuel tank flap	152
⑥ Air outlets	77
⑦ Light switch	52
⑧ Lever for turn signals and main beam headlights	56
⑨ Steering wheel with:	
– Horn	116
– Driver's airbag	
– Controls for audio, telephone and speech dialogue system	
– Paddle levers for manual gearshift (R tronic)	93
⑩ Instrument cluster	10
⑪ Levers and switches for:	
– Windscreen wipers and washer	59
– On-board computer	22
– Menu display	24
– Lap timer	27
– Speed warning function	31
⑫ Navigation system	
⑬ Lockable glove box	73
⑭ Front passenger's airbag	116
⑮ Switch for heated rear window	79

⑯ Air conditioner	75
⑰ Gear lever/selector lever for:	
– Manual gearbox	90
– R tronic	
⑱ Controls for:	
– Audi magnetic ride	88
– Electronic Stabilisation Program (ESP)	132
– Hazard warning lights	56
– Automatic rear spoiler	134
– Audi parking system	85
⑲ Ashtray, cigarette lighter/socket	
⑳ Handbrake	83
㉑ Ignition lock	81
㉒ Adjustable steering column	81
㉓ Lever for cruise control	86
㉔ Instrument lighting	55
㉕ Engine lid lock release	155

Note

- Separate operating instructions are enclosed if the vehicle is equipped with a factory-fitted navigation system.
- The arrangement of switches and controls on right-hand drive models* may be slightly different from the layout shown in ⇒ page 8, fig. 1. However, the symbols used to identify the controls are the same. ■

Instruments and warning/indicator lamps

Instruments

Instrument cluster overview

The instrument cluster is the driver's information centre.

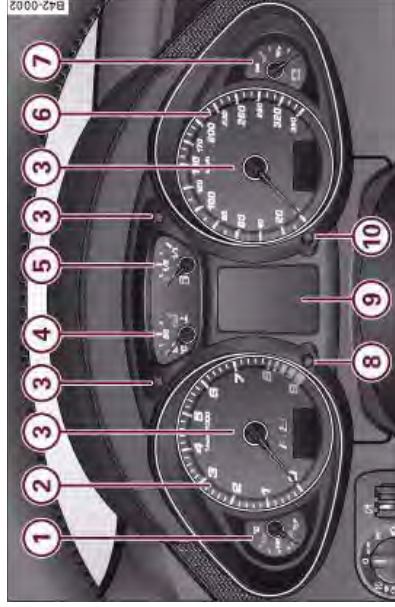

Fig. 2 Instrument cluster

1 Engine oil temperature gauge	10
2 Rev counter incorporating digital clock and date	11, 12
3 Warning and indicator lamps	15
4 Coolant temperature gauge	12
5 Fuel gauge	13
6 Speedometer with mileage recorder	13
7 Voltmeter	14
8 Adjuster/test button	12, 34

9 Driver information system	20
10 Reset button for trip recorder	13

The needles on the dials in the instrument cluster are illuminated when the ignition is switched on. The main instrument lighting (for the dials and needles) comes on when the vehicle's lights are switched on. ■

Engine oil temperature gauge

The engine oil temperature gauge ⇒ fig. 2 only works when the ignition is switched on. In order to avoid possible damage to the engine, please read the following notes for the different temperature ranges.

Engine cold

If the needle is still in the lower range of the dial, this indicates that the engine oil has not yet reached operating temperature. Avoid high engine speeds, full acceleration and heavy engine loads.

Normal temperature

In normal operation the needle will settle somewhere in the centre of the dial once the engine has reached operating temperature. The needle may also go further up when the engine is working hard at high outside temperatures. This is no cause for concern provided the warning lamp  in the display does not start flashing.

Warning lamp

If the symbol  in the display flashes, either the engine oil temperature is too high, or the engine oil level is too low ⇒ page 157.

If the needle is at the top end of the dial, this means the engine oil temperature is too high. **Stop the vehicle, switch off the engine and wait for it to cool down.** If the warning lamp starts flashing again after just a short distance, contact a qualified workshop. ■

Rev counter

The rev counter indicates the number of engine revolutions per minute.

You should select a lower gear, if the engine speed drops below 1500 rpm. The start of the red zone on the dial indicates the maximum engine speed which may be used briefly when the engine is warm and after it has been run in properly. However, it is advisable to change up a gear or lift your foot off the accelerator (or shift out of the R tronic sport model) before the needle reaches the red zone.



Caution

Never allow the rev counter needle \Rightarrow page 10, fig. 2 (2) to go into the red zone on the scale for more than a very brief period: there is a risk of damaging the engine. The start of the red zone on the dial is different for some engine versions. ■

Radio-controlled clock

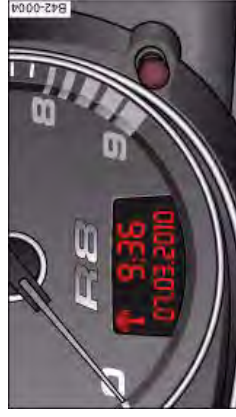

Fig. 3 Detail of the instrument cluster:
Display with signal reception symbol, time and date

When the clock is in "radio-control" mode the signal reception symbol (a radio tower with radio waves) appears in the display \Rightarrow fig. 3. It is then not possible to change the minutes or the date manually. If you take your vehicle into a

different time zone, the hour display will need to be adjusted manually to local time using the adjuster button.

Setting the time zone

- Keep pulling the button \Rightarrow fig. 3 briefly until the time zone display flashes (select setting "0" if you do not wish to change the time zone).
- Then turn the button to the left (to set an earlier time zone: -1/-2) or to the right (to set a later time zone: +1/+2).

Switching date display on and off

- Keep pulling the button briefly until the date display flashes.
- Then turn the button to the left or right.

When the display stops flashing, this means the setting you are performing is completed and the time zone has been successfully stored.

If the clock does not receive a radio signal for three consecutive days, it will automatically switch to "quartz" mode. The signal reception symbol will then disappear. If you need to reset the time and date, proceed as described on \Rightarrow page 12. ■

12 Instruments and warning/indicator lamps

Digital clock with date display

The vehicle is equipped with either a radio-controlled clock or a normal quartz clock with date display.



Fig. 4 Detail of the instrument cluster: Digital clock and date display

The time and date are set using the button ⇒ fig. 4.

Setting the hour

- Pull the adjuster button (the hour display will flash). Then turn the button to the left or right to alter the hour.

Setting the minutes

- Keep pulling the button briefly until the minutes display flashes.
- Then turn the button to the left or right accordingly.

Setting time format (12 or 24 hour display)

- Keep pulling the button briefly until the time format display flashes.
- Then turn the button to the left or right.

Setting the date

- Keep pulling the button briefly until the day, month or year flashes.
- Then turn the button to the left or right.

When the display stops flashing, this means the setting you are performing is completed and the time and date have been successfully stored.

When the ignition is switched off, the display illumination can be switched on for a few seconds by pressing the adjuster/test button ⇒ page 10, fig. 2 ②. ■

Coolant temperature gauge

The coolant temperature gauge ⇒ page 10, fig. 2 ④ only works when the ignition is switched on. In order to avoid possible damage to the engine, please read the following notes for the different temperature ranges.

Engine cold

If the needle is still on the left of the dial, this indicates that the engine has not yet reached operating temperature. Avoid high engine speeds, full acceleration and heavy engine loads.

Normal temperature

In normal operation the needle will settle somewhere in the centre of the dial once the engine has reached operating temperature. The needle may also go further over to the right when the engine is working hard at high outside temperatures. This is no cause for concern provided the warning lamp in the display  does not start flashing. ▲

Warning lamp

If the symbol  flashes in the display, this means that either the coolant temperature is too high or the coolant level is too low ⇒ page 35.

If the needle is over to the far right on the dial, this means the coolant temperature is too high. **Stop the vehicle, switch off the engine and wait for it to cool down.** If the warning lamp starts flashing again after just a short distance, contact a qualified workshop.

WARNING

- Before opening the engine lid and checking the coolant level, please observe the warning information on ⇒ page 155, "Working on components in the engine compartment".
- Never open the engine lid if you can see or hear steam or coolant escaping from the engine compartment; there is a risk of being scalded. Wait until you can no longer see or hear escaping steam or coolant.

Caution

- Additional lights and other accessories in front of the air inlet reduce the cooling effect of the radiator. At high outside temperatures and high engine loads, there is a risk of the engine overheating.
- The front spoiler also ensures proper distribution of the cooling air when the vehicle is moving. If the spoiler is damaged this can reduce the cooling effect, which could cause the engine to overheat. You should obtain professional assistance. ■

Fuel gauge

The gauge only works when the ignition is switched on. When the needle reaches the reserve zone, the symbol  lights up in the

instrument cluster display ⇒ page 36. At this point there are still about 10 litres of fuel left in the tank. This is your reminder to fill up soon.

The tank capacity of your vehicle is given in the **Technical data** section ⇒ page 198.

Caution

Never run the tank completely dry. If there is an irregular fuel supply, misfiring can occur. This allows unburnt fuel to enter the exhaust system, which could cause overheating and damage the catalytic converter. ■

Speedometer with mileage recorder

This instrument indicates the speed of the vehicle and the distance travelled.



Fig. 5 Detail of the instrument cluster: Mileage recorder with reset button

The mileage is normally stated in kilometres (km). On some models, however, the mileage recorder will show miles.

Lower mileage recorder (odometer)

The lower counter records the vehicle's total mileage. ▶

Upper mileage recorder (trip recorder)

The upper mileage recorder shows the distance that has been travelled since the trip recorder was last reset. It is used to measure individual journeys. The last digit of the trip recorder indicates distances of 100 metres or tenths of a mile. The trip recorder can be reset to zero by pressing the reset button ⇒ *page 13*, fig. 5.

When the ignition is switched off, the illumination of the mileage recorder can be switched on for a few seconds by pressing the adjuster/test button ⇒ *page 10*, fig. 2 .

Fault display

If there is a fault in the instruments, the letters **DEF** appear permanently in the trip recorder display. Please have the fault rectified as soon as possible.

Immobiliser

When the ignition is switched on, the security programming of the ignition key is verified electronically.

If an un-coded key is used, **SAFE** will appear continuously in the trip recorder display. The vehicle cannot then be driven ⇒ *page 42*. ■

Voltmeter display

The voltmeter indicates the voltage of the vehicle's electrical system. The voltage of the electrical system should normally be between 12 and 14 volts. If the display drops below 12 volts when the engine is running, have the power supply (battery and alternator) checked by a qualified workshop.

Note

The voltage may drop below 8 volts while the engine is being started. ■

Warning and indicator lamps

Overview







The warning and indicator lamps indicate a number of different functions and possible faults.





Fig. 6 Instrument cluster with warning and indicator lamps

- ① Warning and indicator lamps in the rev counter
- ② Turn signals ⇒ page 17
- ③ Warning and indicator lamps in the driver information system ⇒ page 33
- ④ Warning and indicator lamps in the speedometer ■

① Warning and indicator lamps in the rev counter

	Audi magnetic ride	⇒ page 16
	Tyre pressure too low	⇒ page 16, ⇒ page 172
	Engine management	⇒ page 16
	Electronic stabilisation program (ESP)	⇒ page 16
	Emission control system	⇒ page 17
	Main beam headlights	⇒ page 17
	Rear spoiler	⇒ page 17

④ Warning and indicator lamps in the speedometer

	Cruise control system	⇒ page 17
	Airbag system	⇒ page 17
	Alternator	⇒ page 18

	Seat belt warning lamp	⇒ page 18
	Fault in brake system / handbrake is applied	⇒ page 18
	Anti-lock brake system (ABS)	⇒ page 19

Note

- Yellow symbols are accompanied by one warning chime. The function indicated should be checked as soon as possible.
- A red symbol is accompanied by three warning chimes. The symbol will keep flashing until the fault is corrected. ■

Applies to vehicles: with Audi magnetic ride

Audi magnetic ride

This warning lamp monitors the damping effect of the shock absorbers.

The warning lamp  lights up when the ignition is switched on.

Note

- If the warning lamp lights up while the vehicle is moving, this indicates a vehicle damping malfunction. The suspension should be checked immediately by a qualified workshop. ■

Applies to vehicles: with tyre pressure monitoring system

Tyre pressure monitoring system

The tyre pressure should be corrected as soon as possible if it is too low.

If the  symbol appears, the tyre pressure on at least one of the wheels is too low.

- Stop the vehicle.
- Check the tyre(s).
- Adjust the tyre pressure ⇒ page 167.

For more detailed information on the **tyre pressure monitoring system** please refer to ⇒ page 172. ■

Engine management EPC

This warning lamp monitors the engine management system.

The  warning lamp (Electronic Power Control) lights up when the ignition is switched on to show that the lamp is working properly.

Note

- If the warning lamp lights up while the vehicle is moving, this indicates a fault in the engine management system. The engine should be serviced by a qualified workshop without delay. ■

Electronic stabilisation program (ESP)

This warning lamp monitors the electronic stabilisation program.

The warning lamp  has the following functions:

- It flashes when the ESP or traction control system (ASR) intervenes while the vehicle is in motion.
- It lights up when the ignition is switched on and should go out again after about 2 seconds. This signals that the lamp is working properly.
- It will light up continuously if there is a malfunction in the ESP.
- It will light up continuously if the ESP is switched off. ▲

- It will also come on if a fault should occur in the ABS because the ESP operates in conjunction with the ABS.
If the warning lamp lights up and stays on after the engine is started, this may mean that the control system has temporarily switched off the ESP. In this case the ESP can be reactivated by switching the ignition off and then on again. If the warning lamp goes out, this means the system is fully functional.
For further information on the ESP ⇒ *page 132*.

If the battery is disconnected and then reconnected, this warning lamp will light up when the engine is started and stay on until you have driven a few metres. ■

Emission control system

If the warning lamp **lights up continuously** you should take your vehicle to a qualified workshop as soon as possible in order to have the fault rectified.

If the warning lamp **flashes** drive on at reduced speed and seek professional help in order to avoid damage to the catalytic converter.

For further information on the catalytic converter ⇒ *page 138*. ■

Main beam headlights

The indicator lamp  lights up when the main beams are on or when the headlight flasher is operated.

For further information on the main beam headlights ⇒ *page 56*. ■

Rear spoiler



This warning lamp monitors the automatic electrically operated rear spoiler.

The warning lamp  has the following functions:

- It lights up when the ignition is switched on and should go out again after about 3 seconds. This signals that the lamp is working properly.

- It lights up if a malfunction occurs on the automatic rear spoiler.
For further information on the automatic rear spoiler ⇒ *page 134*. ■

Turn signals and hazard warning lights

Depending on which turn signal is operated, either the left  or right  indicator lamp flashes. Both indicator lamps will flash when the hazard warning lights are switched on.

If one turn signal should fail, the indicator lamp will start flashing twice as fast.

For further information on the turn signals ⇒ *page 56*. ■

Applies to vehicles: with cruise control system

Cruise control

The indicator lamp  in the instrument cluster lights up when the cruise control system is operating. ■

Airbag system

This warning lamp monitors the airbag and seat belt tensioner system.

The warning lamp  should light up for a few seconds when the ignition is switched on. ▲

If the warning lamp does not go out, or if it lights up, flashes or flickers when the vehicle is moving, this indicates a malfunction in the system. This is also the case if the warning lamp does not light up when the ignition is switched on.





WARNING

If a malfunction should occur, have the system checked immediately by a qualified workshop. If this is neglected, there is a risk that the airbag system and/or belt tensioners may not be activated in an accident. ■

Alternator

The warning lamp signals a fault in the alternator or in the vehicle's electrical system.

The warning lamp  lights up when the ignition is switched on. It should go out when the engine starts running.

If the warning lamp  lights up when you are driving, you can normally continue as far as the nearest qualified workshop. However, you should avoid using electrical equipment that is not absolutely necessary because this will drain the battery.



Caution

If the coolant warning lamp  in the instrument display lights up as well while driving => page 35, stop the vehicle immediately and switch off the engine. In this case the coolant pump is no longer being driven, and there is a risk of engine damage. ■

Seat belt warning lamp





The warning lamp acts as a reminder to fasten the seat belts.

After switching on the ignition, the warning lamp  will remain lit until the driver has fastened his seat belt. When the vehicle has gathered speed you will also hear a warning chime.

For further information on the seat belts => page 109. ■

Brake system

The warning lamp flashes if the brake fluid level is too low or if there is a fault in the ABS system.

If the warning lamp  flashes (and the handbrake is not applied), stop the vehicle and obtain professional assistance => . If a failure should occur in the ABS, the ABS warning lamp  will light up together with the brake warning lamp  => .

Handbrake applied

The warning lamp  also lights up when the handbrake is applied. If you drive by mistake with the handbrake still applied, you will hear a warning buzzer.



WARNING

- If the brake warning lamp does not go out, or if it lights up when driving, the brake fluid level in the reservoir is too low – this may cause an increased accident risk. Stop the vehicle and do not drive on. You should obtain professional assistance.
- If the brake warning lamp lights up together with the ABS warning lamp, this can mean that the control function of the ABS is out of action. As a result the rear wheels can lock relatively easily when braking. This could cause the tail of the vehicle to skid

⚠ WARNING (continued)

sideways. Drive carefully to the nearest qualified workshop and have the fault rectified. ■

Anti-lock brake system (ABS) 

The warning lamp monitors the ABS and the electronic differential lock (EDL).

The warning lamp  lights up for a few seconds when the ignition is switched on and while the engine is being started. The lamp goes out again once the system has run through an automatic test sequence.



There is a fault in the ABS if:

- the warning lamp  does not light up when the ignition is switched on,
- the warning lamp does not go out again after a few seconds,
- the warning lamp lights up when the vehicle is moving.

The vehicle can still be braked in the normal way (except that the ABS control function is out of action). Please take the vehicle to a qualified workshop as soon as possible. For further information on the ABS ⇒ *page 132*.

If a fault occurs in the ABS, the ESP warning lamp will also light up.

Fault in the main brake system



If the ABS warning lamp  lights up together with the brake warning lamp  ⇒ *page 35*, this indicates a fault in the ABS function, and possibly a malfunction in the main brake system as well ⇒ **⚠**.

If there is a **malfunction in the brake system** the symbol  will light up in the instrument cluster. Please refer to ⇒ *page 18*.

Fault on the electronic differential lock (EDL)

The EDL works in conjunction with the ABS. If a malfunction should occur in the EDL, this is indicated by the ABS warning lamp . Please take the vehicle to a qualified workshop as soon as possible. For further information on the EDL ⇒ *page 132*.

⚠ WARNING

- If the brake warning lamp  lights up together with the ABS warning lamp , the brake fluid level in the reservoir is too low and this may cause an accident. Stop the vehicle and do not drive on. You should obtain professional assistance.
- If the brake fluid level is OK, the fault in the brake system may have been caused by a failure of the ABS control function. As a result the rear wheels can lock relatively easily when braking. This could cause the tail of the vehicle to skid sideways. Drive carefully to the nearest qualified workshop and have the fault rectified. ■

Driver information system

Introduction

The driver information system in the instrument cluster shows you the status of various on-board systems at a glance.



Fig. 7 Display: Standard display



Fig. 8 Windscreen wiper lever: Reset button and rocker switch

Standard display

The following information is shown in the driver information system display when the ignition is on:

- CD* in the CD player or current radio* station
- Outside temperature*: At temperatures below +5°C a snowflake symbol appears next to the temperature display ⇒ 

- Door catches, engine lid and front lid warning: The warning lamp comes on if the door, engine lid or front lid is open.

Further functions

Press the [Reset] button ⇒ fig. 8 one or more times to call up the following functions in the driver information system display:

On-board computer	⇒ page 22
Digital speedometer*	
Menus	⇒ page 24
Lap timer	⇒ page 27

The speed warning function is also displayed in the driver information system. For information on how to select this setting please refer to ⇒ page 31.

Auto-check control

The system runs a check on certain components and functions when the ignition is switched on and while the vehicle is moving. It gives an audible warning if a fault should occur or if servicing is required, and a red or yellow warning symbol (in some cases with a corresponding driver message) appears in the dashboard display ⇒ page 33.



WARNING

Do not rely on the outside temperature display as an ice warning. Please bear in mind that there may be ice on the roads even at outside temperatures of +5 °C: beware of ice patches.



Note

- On vehicles with R tronic, the displays only appear after the driver has engaged a gear.

- On vehicles equipped with the Audi navigation system* the displays may vary from the normal lay-out during route guidance. ■

Service interval display

This display reminds the driver when the next routine service is due.



Fig. 9 Display: Service interval display

Displaying distance to next service

When you pull the adjuster/test button (10) ⇒ page 10, fig. 2 briefly with the ignition switched on, the display will show how far the vehicle can be driven before the next service is due. The remaining distance to the next service is updated every 500 km.

On a new vehicle, or after a service has been carried out, the display will always show **SERVICE IN ----- KM --- DAYS** for the first 500 km. This also applies to vehicles with "LongLife Service".

Service reminder

The following message will appear in the display when the ignition is switched on, starting at around 2000 km¹⁾ before the next service is due:

SERVICE IN 2000 KM --- DAYS

The display reverts back to the standard display after about 5 seconds. The remaining distance to the next service is updated (and displayed accordingly) every time the ignition is switched on, until the service becomes due.

Service due

The next service is due when the message **SERVICE!** appears in the display immediately after switching on the ignition. The display reverts back to the standard display after about 5 seconds.

Resetting the display

The display is reset by the workshop after the service has been carried out. However, if the service was not carried out by a qualified workshop, the service interval display will have to be reset as described in the following. It is then only possible to set fixed service intervals of 15,000 km.

- Switch on the ignition.
- When you pull the adjuster/test button (10) ⇒ page 10, fig. 2 **SERVICE!** will appear in the display.
- Pull the button until **SERVICE IN ----- KM --- DAYS** is shown in the display. The display switches out of the reset mode if you do not pull the reset button within 5 seconds.



Note

- The distance to the next service cannot be called up if the system has detected a fault (red symbol). ▲

¹⁾ When exactly the service reminder will appear for the first time depends on the way the vehicle is driven (e.g. short or long trips).

- Do not reset the service interval display between services - otherwise the display will be incorrect.
- The information in the service interval display remains intact if the battery is disconnected.
- On vehicles equipped with the driver information system the service interval display can also be called up using the on-board computer. ■

On-board computer

Introduction

The on-board computer provides you with useful information during a journey, including average and current fuel consumption, average speed, fuel range, driving time and distance covered.



Fig. 10 On-board computer: Memory 1

Press the [Reset] button (B) ⇒ page 23, fig. 11 to switch back and forward between the functions of on-board computers 1 and 2. The number in the display ⇒ fig. 10 indicates which of the two memories is currently in use. The figure 1 means that the display is showing the information in the single journey memory (on-board computer 1). The figure 2 means that the display is showing the information in the total journey memory (on-board computer 2).

Single journey memory (on-board computer 1)

The single journey memory processes the information on a journey from the time the ignition is switched on until it is switched off. If the journey is resumed **within two hours** after the ignition is switched off, the new figures are automatically included in the calculation. If the journey is interrupted for **more than two hours** the stored information is automatically erased when you resume your journey.

Total journey memory (on-board computer 2)

Unlike the single journey memory, the total journey memory is not erased automatically. In this way, you can determine the period for which you wish the on-board computer to supply figures.

Fuel range

The estimated fuel range is displayed in km. The fuel range is displayed in increments of 10 km.

Average fuel consumption

This mode shows the average fuel consumption since the memory was last cancelled in litres/100 km.

Current fuel consumption

The display shows the current fuel consumption in litres/100 km. When the vehicle is stationary the computer will display the last value in the memory.

Average speed

This mode shows the average speed driven since the memory was last cancelled (in km/h).

Driving time

This display shows the period of time which has elapsed since the memory was last cancelled. The longest possible period it can cover is 999 hours and 59 minutes.

Distance covered

This display shows the distance you have covered since the memory was last cancelled. The longest possible distance which can be recorded is 9999.9 km.

Note

- The displays for fuel consumption (average and current consumption), fuel range and speed are shown in metric units.
- The information in the memory is cancelled if the battery is disconnected. ■

Controls

The on-board computer is controlled by means of two switches on the windshield wiper lever.



Fig. 11 Windscreen wiper lever: On-board computer controls

Activating on-board computer

- Press the **[Reset]** button **(B)** repeatedly until the on-board computer (memory 1 or 2) is displayed ⇒ *page 22*, fig. 10.

Selecting a function

- Press the top or bottom of the function selector switch **(A)** ⇒ fig. 11. This displays the functions of the on-board computer in sequence.

Resetting to zero

- Press and hold the **[Reset]** button **(B)** for at least two seconds.

The following values can be reset to zero using the **[Reset]** button:

- Driving time
- Distance covered
- Average fuel consumption
- Average speed

The on-board computer can only be operated while the ignition is switched on. When the ignition is switched on, the display shows the function that was last selected.

Note

- You can also reset the values to zero in the menu display **(RESET)** ⇒ *page 24*.
- The information in the memory is cancelled if the battery is disconnected. ■

Menus

Introduction



Fig. 12 Windscreen wiper lever: Controls for menu display



Fig. 13 Display: Main menu

Some of the functions in your vehicle can be adjusted, activated and controlled via **menus** (e.g. parking aid*). With the aid of the menus you can then also select the information you wish to see on the display. This only works when the ignition is on. The menus are activated via the **[Reset]** button and the rocker switch on the windscreen wiper lever ⇒ fig. 12.

The **main menu** lists the different display types (for technical reasons, illustrations in this manual are in German language):

Set (Einstellen)

Check (Abfragen)

Menu off (Menü aus)

Help (Hilfe)

The 4 main menu options have the following submenus:

Set	Clock	⇒ page 26
	Computer	⇒ page 26
	Speed warning	⇒ page 32
	Language: you can select one of 6 languages.	⇒ page 26
	Units: for measuring distance, fuel consumption and temperature	⇒ page 26
	Lights	⇒ page 52 ⇒ page 54
	Wipers (service position)	⇒ page 61
	Windows	⇒ page 43
	Doors (Auto Lock)	⇒ page 43
	Parking aid*	⇒ page 85
Check	Service	
	Chassis number	⇒ page 196
Menu off	The menu display will disappear and the lap timer will appear.	
Help	The Help function explains the symbols in the menu display.	

Selecting options from the menu

The menu display is called up via the **(Reset)** button and the rocker switch on the windscreen wiper lever. Use these controls to make checks and adjust the settings.



Fig. 14 Windscreen wiper lever: Controls for menu display

Functions of the **(Reset)** button (A) and the rocker switch (B) ⇒ fig. 14:

Calling up the menu

- Press the **(Reset)** button (A) until the menu display ⇒ fig. 15 appears.

Selecting options and setting values

- Press rocker switch (B) to select options from the menu. Press "up" or "down" on the switch to select the options accordingly.

Entering and confirming

- Press the **(Reset)** button (A).

Returning to main menu

- Press the **(Reset)** button for longer than 2 seconds to return to the main menu from any of the menu levels.

Use the rocker switch to select the menus and adjust various values. A cursor will appear in front of the values you have selected.

By pressing the **(Reset)** button, you can confirm the option you have selected or the value you have set. **Selected functions** are marked with a tick or are activated immediately. ■

Calling up help



Fig. 15 Display: Main menu, "Help" (Hilfe) selected



Fig. 16 Display: information appearing in Help function

- Press the **(Reset)** button. The main menu will appear ⇒ page 24, fig. 13.
- Use the rocker switch to select the **Help** (Hilfe) function.
- Press the **(Reset)** button to confirm your selection. ▲

- Press the **Reset** button again to exit from the Help function.

The Help menu is for your information only. It is not possible to make settings via this menu.

The following symbols are used:

Cursor	Selected function	Function
>	Cursor	Current position in menu
✓	Tick	Function is selected/activated
☐	Box	Not selected
▲	Triangle pointing upwards	Previous page
▼	Triangle pointing downwards	Next page

Setting (part 1)

The settings in the driver information system are menu-driven.



Fig. 17 Display: "Set" (Einstellen) menu, "Computer" selected (Page 1)



Fig. 18 Display: "Lights" (Beleuchtung) menu selected (Page 2)

- Press the **Reset** button. The main menu will appear ⇒ page 24, fig. 13.
- Keep pressing the rocker switch briefly until the display shows **Set (Einstellen)**.
- Press the **Reset** button. The display will show all the available menus.
- Press the rocker switch repeatedly until the desired line is highlighted (cursor) ⇒ fig. 17.
- Press the **Reset** button.
- You can scroll within the menu to view the full list by selecting the "Next page" or "Previous page" symbol and pressing the pushbutton.

If you select Computer and confirm by pressing the **Reset** button, the display will show two computer menus (Computer 1 and Computer 2). Now you can select the desired computer menu with the rocker switch and activate it by pressing the **Reset** button. ■

Setting (part 2)



Fig. 19 Display:
"Computer 1" menu,
"Fuel range" (Reich-
weite) selected



Fig. 20 Display:
"Computer 1" menu,
"Back" (Zurück)
selected

- Press the rocker switch repeatedly until the desired function is selected in the menu (highlighted on a red background) ⇒ fig. 19.
- Activate or deactivate the selected function by pressing the **[Reset]** button to enter or remove a tick in the box.
- To go back to a previous menu, press the rocker switch until **Back (Zurück)** is selected ⇒ fig. 20, then press the **[Reset]** button.

In some cases it is necessary to enter values or figures, for example when setting the date. This is also done by pressing the rocker switch. ■

Lap timer

Introduction

The lap timer allows you to record and analyse lap times.

The time (in minutes, seconds and tenths of a second) is shown in the instrument cluster display. The hour automatically appears in the display if the session lasts for over an hour. The maximum time which can be recorded in a single measurement is 99 hours, 59 minutes, 59 seconds and 9/10 of a second. If this time is exceeded, the lap timer will automatically stop recording and switch to the pause mode ⇒ *page 29*.



WARNING
Please direct your full attention to the road at all times! As the driver, you have full responsibility for the safety of the vehicle and other road users. For this reason, you should only use the functions in a manner that allows you to maintain control of the vehicle in all situations - accident risk!



Note

The on-board computer can be used in the normal way while the stopwatch of the lap timer is running. ■

Calling up the lap timer



Fig. 21 Controls



Fig. 22 Display: Lap timer

- With the ignition switched on, keep pressing the **[RESET]** button (B) ⇒ fig. 21 until the lap timer ⇒ fig. 22 appears. ■

Recording your first lap time



Fig. 23 Display: Lap 1



Fig. 24 Display: Lap 1 recorded; lap 2 started

The current lap appears at the top of the display: e.g. **LAP 2** (= second lap).

Starting the lap time

- Press the top part of the rocker switch. Line (A) ⇒ fig. 23 shows the current lap time.

Storing the lap time

- Press the top part of the rocker switch again. The time for the next lap starts simultaneously. ▲

Each time a lap time is stored, it moves one line up the display ① ⇒ page 28, fig. 24. The time for the new lap appears in the bottom line ②. ■

Recording further lap times



Fig. 25 Display: Lap 2 recorded

Each time you press the top part of the rocker switch when the lap timer is running, the current lap time is stored and the next lap time is started simultaneously. Simply repeat this procedure to record subsequent laps.

The current lap time always appears in the bottom line of the display ③ ⇒ fig. 25.

When you store a lap time, it moves up one line ④ ⇒ fig. 25 from the bottom of the display. The previous lap time also moves up one line again ⑤. The time for the new lap appears in the bottom line ③. ■

Displaying split times and pausing the lap timer

The split time (for an intermediate section of a lap, etc.) is marked with an asterisk.



Fig. 26 Display: Split time

You can retrieve split times for different sections of the lap. You can pause the lap timer if you want to take a break during a session.

Displaying a split time and pausing the lap timer

- Press the bottom part of the rocker switch to **display the split time** ③. The recording of the lap time continues in the background while the split time (marked with an asterisk) is displayed.
- Press the bottom part of the rocker switch again if you want to **pause the timer**. The lap timer is interrupted and the asterisk in the bottom line disappears.

Resuming recording of lap time

- Press the top part of the rocker switch to resume lap time recording from the split time or pause mode. ■

Switching the display between lap timer and on-board computer

You can call up information from the on-board computer while the stopwatch of the lap timer is running.

Calling up the on-board computer

- Briefly press the **[Reset]** button to display the on-board computer. You can now use the on-board computer in the usual way.

Calling up the lap timer

- Keep pressing the **[RESET]** button until the lap timer ⇒ *page 28*, fig. 22 appears. ■

Finishing the session and evaluating or resetting lap times



Fig. 27 Display:
Fastest, slowest and
average lap times

After evaluating the lap times, you can reset the lap timer data or continue recording further laps ⇒ *page 31*.

Finishing the lap time session

- When you cross the start/finish line, press the top part of the rocker switch to store the final lap time. The new lap time (which always starts simultaneously) will not be recorded if you now evaluate the lap times.

Evaluating lap times

- Press the **[Reset]** button for about two seconds. A summary of key lap times appears in the display.

Resetting the lap timer

- While the overall results are shown in the display ⇒ fig. 27, press and hold the **[Reset]** button for at least two seconds to reset all data of the lap timer to zero.

Overall lap time results

The display will show ⇒ fig. 27:

- + the fastest lap time
- the slowest lap time
- ∅ the average lap time



Note

- Recorded lap times cannot be deleted individually from the overall results.
- In addition to the overall results ⇒ fig. 27, the lap timer will only display the recorded times for the last lap and last lap but one ⇒ *page 29*, fig. 25.
- The data recorded in the lap timer remain stored after the ignition is switched off.
- The session can be resumed later ⇒ *page 31*.
- All the data will remain stored in the lap timer unless the driver deliberately resets the lap timer. ■

Resuming the lap time session later

When you have evaluated the lap times, you can resume the session and continue recording lap times later.

- Keep pressing the **[Reset]** button until the lap timer appears ⇒ [page 30](#), [fig. 27](#).
- Press the top part of the rocker switch to start recording a new lap time.
- To record further lap times, repeat the procedure described earlier ⇒ [page 29](#), "Recording further lap times". To evaluate the overall results, refer to ⇒ [page 30](#), "Finishing the session and evaluating or resetting lap times". ■

Speed warning function

Applies to vehicles: with speed warning function

Introduction

The speed warning function can help you keep below a pre-set maximum speed.



Fig. 28 Display: Speed warning

The speed warning function will warn you if the vehicle exceeds the pre-set maximum speed. The system gives an audible warning signal if the set speed is exceeded by about 10 km/h. A warning symbol will also appear in the display ⇒ [fig. 28](#).

The speed warning function has two different **warning levels***, which operate independently and serve slightly different purposes:

Speed limit warning 1

With speed limit warning 1, the maximum speed can be changed while driving. The speed limit that has been set remains stored until the ignition is switched off.

The speed limit warning symbol for speed warning 1 ⇒ [fig. 28](#) will appear in the display if you exceed the pre-set speed. It goes out again if the speed is reduced below the set speed limit.

The symbol also goes out if the speed is *increased* to more than about 40 km/h above the set speed for at least 10 seconds. However, this does not cancel the speed limit that was originally set.

Setting speed limit warning 1 ⇒ [page 32](#).

Speed limit warning 2

With speed limit warning 2, the speed limit can only be changed or cleared when the ignition is switched off. You are recommended to store this speed limit warning if you *always* wish to be reminded of a particular speed limit. This could be when driving in countries with general speed limits, or if you need to keep below a particular speed when winter tyres are fitted, etc.

The speed limit warning symbol for speed warning 2 will appear in the display if you exceed the pre-set speed. Unlike speed limit warning 1, the warning symbol only goes out once the road speed has dropped below the stored value again.

Setting speed limit warning 2 ⇒ [page 32](#).

**Note**

Please bear in mind that, even with the speed warning function, it is still important to keep a check on the car's speed with the speedometer and to observe the statutory speed limits. ■

Applies to vehicles: with speed warning function

Setting speed limit warning 1

Speed limit warning 1 is controlled via the adjuster/test button.

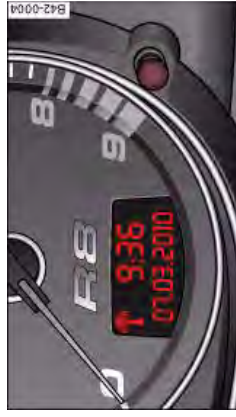



Fig. 29 Detail of the instrument cluster:
Adjuster/test button

Selecting speed limit

- Drive at the desired maximum speed.
- Press the adjuster/test button ⇒ fig. 29 and hold it down until the symbol ⇒ page 31, fig. 28 appears.

Clearing speed limit

- Drive the vehicle at a minimum of 5 km/h.
- Press the adjuster/test button for at least two seconds.

The speed warning symbol  lights up briefly in the display when the button is released to confirm that the selected speed has been stored. The speed limit that has been set remains stored until

another speed is set with a brief push of the button, or until the memory is cleared with a long push of the button. ■

Applies to vehicles: with speed warning function

Setting speed limit warning 2

Speed limit warning 2 is set using the switches on the windscreen wiper lever.

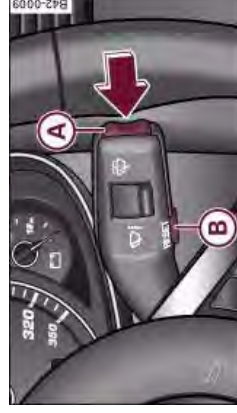

Fig. 30 Controls

Selecting speed limit

- Switch off the ignition.
- Briefly press the adjuster/test button in the instrument cluster ⇒ fig. 29. The mileage recorder display and the digital clock will light up.
- Press the adjuster/test button for at least 2 seconds. The display will show the speed limit which is currently set **or**, if no speed limit has been set, the crossed out warning symbol for speed limit 2.
- To change the speed limit, press the top or bottom of the function selector switch on the windscreen wiper lever (A ⇒ fig. 30. The speed limit displayed will then increase or decrease in increments of 10 km/h. ▲

Clearing speed limit

- Switch off the ignition.
- Briefly press the adjuster/test button in the instrument cluster ⇒ *page 32*, fig. 29. The mileage recorder display and the digital clock will light up.
- Press the adjuster/test button for at least 2 seconds. The display will show the speed limit which is currently set.
- Now press and hold the **Reset** button on the windscreen wiper lever **(B)** ⇒ *page 32*, fig. 30 until the crossed-out warning symbol for speed limit 2 appears on the display.

The display lighting for the mileage recorder and digital clock goes off again a few seconds after the button is released.



Note

This speed limit function can also be operated via the on-board computer ⇒ *page 25*, "Selecting options from the menu". ■

Notes and symbols

Red symbols

A red symbol warns of a serious malfunction.

- Stop the vehicle.
- Switch off the engine.
- Check the function displayed. Obtain professional assistance if necessary.

	Fault in the brake system	⇒ <i>page 35</i>
	Coolant level too low / coolant temperature too high	⇒ <i>page 35</i>
	Engine oil pressure too low	⇒ <i>page 36</i>
	Tyre pressure monitoring system*	⇒ <i>page 36</i>

A red symbol is accompanied by three warning chimes. The symbol will keep flashing until the fault is corrected. If several faults are detected at the same time, the symbols are displayed one after the other for about 2 seconds at a time.



Note











- You can press the left adjuster button to display a message that gives you more information.
- On vehicles equipped with a navigation system the warning symbol is displayed in the top section of the display while the route guidance is active. ■

Yellow symbols

A yellow symbol indicates a malfunction or other item requiring attention.

	Fuel level low	⇒ <i>page 36</i>
	Check engine oil level	⇒ <i>page 37</i>
	Engine oil sensor defective	⇒ <i>page 37</i>

34 Driver information system

	Brake pads worn	⇒ page 37
	Speed warning 1*	⇒ page 37
	Speed warning 2*	⇒ page 37
	Dynamic headlight range control faulty	⇒ page 37
	Washer fluid level low	⇒ page 37
	Battery voltage too high or too low	⇒ page 37
	Bulb monitor	⇒ page 37
	Brake light failure	⇒ page 38
	Light sensor/rain sensor (automatic headlights) defective	⇒ page 38
	Selector lever defective* No R gear**	⇒ page 38
	Clutch overheating*	⇒ page 38

Yellow symbols are accompanied by one warning chime. The function indicated should be checked as soon as possible. If several faults are detected at the same time, the symbols are displayed one after the other for about 2 seconds at a time. ■

Driver messages

Additional messages to assist the driver are displayed in conjunction with the warning lamps and symbols in the instrument cluster.

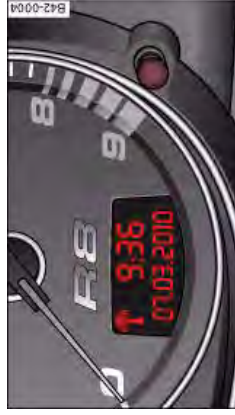



Fig. 31 Detail of the instrument cluster: Adjuster/test button

The display will show the appropriate message if the system detects a bulb failure ⇒ page 37; if the brake pads are worn or you have not yet selected a gear on a vehicle with R tronic.

The driver can also call up messages in the display for additional information if a red warning symbol starts flashing.

Calling up driver messages

For example, in the event of an oil pressure malfunction the oil pressure symbol  will appear in the display. If you now press the adjuster/test button ⇒ fig. 31 for at least one second, the following message will appear in the display:

SWITCH OFF ENGINE AND CHECK OIL LEVEL



The message will disappear from the display after about 5 seconds. If required, the message can be called up again by briefly pressing the adjuster/test button. ■

Fault in the brake system

The warning lamp flashes when the handbrake is applied, or if the brake fluid level is too low or if there is a fault in the ABS system.

If the symbol  flashes in the display when the handbrake is not applied, there is a fault in the brake system. One of the following messages will appear in the display together with the symbol:

- Stop vehicle and check brake fluid level**
- Brake fault ! Drive carefully to nearest workshop**

- Stop the vehicle.
 - You should obtain professional assistance.
- If the ABS fails, the ABS warning lamp  will light up together with the brake warning symbol  ⇒ .

Handbrake applied

The warning lamp  also lights up when the handbrake is applied. In addition to this, a warning buzzer will sound after driving for 3 seconds at a speed above 5 km/h.

WARNING

- If the brake fluid level in the reservoir is too low, this could result in an accident. Do not drive on. You should obtain professional assistance.
- If the brake warning lamp lights up together with the ABS warning lamp, this can mean that the control function of the ABS is out of action. As a result the rear wheels can lock relatively easily when braking. This could cause the tail of the vehicle to skid sideways. Drive carefully to the nearest qualified workshop and have the fault rectified. ■

Fault in the cooling system

Faults in the cooling system must be rectified immediately.

If the  symbol flashes in the display, this means that either the coolant temperature is too high or the coolant level is too low. The following message will appear in the display together with the symbol:

Switch off engine, check coolant level

- Stop the vehicle.
- Switch off the engine.
- Check the coolant level ⇒ page 160.
- Add more coolant if necessary ⇒ page 160.
- Wait for the symbol to go out before driving on.
- Obtain professional assistance if necessary.

If the coolant level is correct, the overheating may be caused by a malfunction of the radiator fan.

If the alternator warning lamp lights up as well ⇒ page 18, it is possible that the drive belt has broken.

WARNING

- If your vehicle should break down for technical reasons, stop it at a safe distance away from moving traffic, switch off the engine and turn on the hazard warning lights ⇒ page 56, "Hazard warning lights ".
- Never open the engine lid if you can see or hear steam or coolant escaping from the engine compartment; there is a risk of being scalded. Wait until you can no longer see or hear escaping steam or coolant.

Driver information system

WARNING (continued)

- The engine compartment of any motor vehicle is a dangerous place. Before carrying out any work in the engine compartment, switch off the engine and allow it to cool down. Please observe the important safety warnings ⇒ *page 155*, "Working on components in the engine compartment".

Caution

Do not drive on if the symbol  has come on to indicate a fault in the cooling system, otherwise there is a risk of damaging the engine. ■

Engine oil pressure too low

If the engine oil pressure is too low the fault must be rectified immediately.

If the  symbol flashes in the display, the oil pressure is too low. The following message will appear in the display together with the symbol:

Switch off engine and check oil level

- Stop the vehicle.
 - Switch off the engine.
 - Check the engine oil level ⇒ *page 157*.
 - Obtain professional assistance if necessary.
- If the engine oil level is too low**
If the engine oil level is too low, add more oil ⇒ *page 158*.

If the engine oil level is correct

If the  symbol flashes and the engine oil level is correct, obtain professional assistance. Do not drive on. Do not continue to run the engine, **not even at idle speed**. ■

Applies to vehicles: with tyre pressure monitoring system

Tyre pressure monitoring system

The tyre pressure should be corrected as soon as possible if it is too low.

If the  symbol appears, the tyre pressure on at least one of the wheels is too low. The message **Tyre pressures too low** will be displayed.

- Stop the vehicle.
- Check the tyre(s).
- Adjust the tyre pressure ⇒ *page 167*.

For more detailed information on the **tyre pressure monitoring system** please refer to ⇒ *page 172*. ■

Fuel level low

When this symbol  comes on for the first time, there are about 10 litres of fuel left in the tank. You should fill up as soon as possible ⇒ *page 152*.

If this warning symbol lights up although the fuel tank is sufficiently filled, there is a malfunction in the fuel tank system. The display will also show the driver message **Tank system malfunction ! Contact workshop**. Please take the vehicle to a qualified workshop. ■

Check engine oil level

Please check oil level

If the  symbol lights up, add 1 litre of oil at the next opportunity ⇒ [page 158](#). ■

Engine oil sensor defective

If the  symbol lights up, take the vehicle to a qualified workshop and have the oil level sensor checked. ■

Front brake pads worn

If the  symbol lights up, have the front brake pads (and, for safety's sake the rear pads as well) inspected by a qualified workshop. ■

Speed warning 1

If the  symbol lights up, this means you are exceeding the speed that has been pre-set with the speed warning function. You should reduce your speed accordingly ⇒ [page 31](#). ■

Speed warning 2

If the  symbol lights up, this means you are exceeding the speed that has been pre-set for speed warning 2. You should reduce your speed accordingly ⇒ [page 31](#). ■

Headlight range control defective

This symbol  indicates a malfunction in the dynamic headlight range control. Take the vehicle to a qualified workshop to have the dynamic headlight range control function repaired. ■

Washer fluid level low

If the  symbol lights up, top up the fluid for the windscreen washer and headlight washer system ⇒ [page 164](#). ■

Battery voltage too high or too low

If the  symbol lights up, take the vehicle to a qualified workshop and have the following items checked:

- Poly-V belt
- Battery condition

It is also advisable to check whether the alternator warning lamp has come on ⇒ [page 18](#). ■

Bulb monitor

The bulb monitor checks whether the lights on the vehicle are working.

If a defective bulb is detected, or if one of the lights has failed for any reason, the bulb monitor symbol  will appear in the display together with an additional message (which goes out after 5 seconds). For instance, if the rear left turn signal is not working, the display in the instrument cluster will show the following message:

REAR LEFT TURN SIGNAL ▲

Driver information system

The message disappears after 5 seconds. Press the adjuster/test button  => *page 10*, fig. 2 briefly if you wish to call up the message again.

If the display indicates that one of the lights is not working, this can have a number of causes:

- Bulb failure => *page 193*.
- A "blown" fuse => *page 190*, "Changing fuses".
- Defective electrical wiring.

Have the components replaced or the wiring repaired as necessary by a qualified workshop.

WARNING

- **Bulbs are sensitive to pressure. The glass can break when you touch the bulb, causing injury.**
- **Incorrect handling of the high-voltage element of xenon gas-discharge bulbs can have potentially fatal consequences.** ■

Brake light failure

If the symbol  or the text BRAKE LIGHT lights up, check the following components:

- Brake light bulbs
- Wiring connections
- Brake light switch

Have the components repaired or replaced by a qualified workshop.

Note

The brake light switch is only tested during the initial systems check after starting the engine. ■

Applies to vehicles: with light sensor/ rain sensor

Light sensor/rain sensor

This indicator lamp comes on if the automatic headlights/ automatic wipers are defective.

If the  symbol appears, this means that the light sensor/ rain sensor is not functioning. For safety reasons, the dipped beam headlights will then be switched on permanently when the light switch is set to the **AUTO** position. However, you can still switch the lights on and off in the normal way with the light switch. If the rain sensor is defective, the functions operated via the windscreen wiper lever will still be available. You should have the light sensor/ rain sensor checked by a qualified workshop as soon as possible. ■

Applies to vehicles: with R tronic

Selector lever defective and

Selector lever defective! No R gear!



If these symbols light up, there is a fault in the R tronic selector lever. The indicators on the selector lever will go out or flash. It is no longer possible to engage reverse gear. If you were using the gearbox in manual mode, it will switch back to automatic mode.

You can continue to change gear manually. Starting in neutral (N), pull the  paddle lever on the steering wheel to engage first gear. The gearbox will now remain in manual mode and you can select the gears using the paddle levers.

You should have the selector lever checked by a qualified workshop as soon as possible. ■

Applies to vehicles: with R tronic

Clutch overheating and

  Clutch is overheating ! If possible please stop vehicle. ▶

If these symbols light up, the clutch has overheated and could be damaged if you continue driving.

Stop the car and obtain professional assistance. ■

Controls

Safety

Driving tips

General maintenance

Self-help

Technical data

Doors and windows

Remote control keys

Set of keys



Fig. 32 Set of keys



Fig. 33 Remote control key: indicator lamp

The set of keys for your vehicle ⇒ fig. 32 includes:

- Ⓐ two remote control keys
- Ⓑ one spare key

Remote control key

The remote control key will lock and unlock the car via the central locking system and start the engine. Press the release button

⇒ fig. 32 (arrow) to make the key spring out of the handle and to fold it back in.

Spare key

The spare key should be used only temporarily, if the remote control key has been misplaced or lost.

Replacing a key

If one of the keys has been lost, you should take the vehicle to an Audi R8 dealer to have the remote control coding for *that* key deactivated. For this purpose you should bring all available keys with you.

It is also important to notify your insurance company if a key has been lost.

Checking the key battery level

The indicator lamp ⇒ fig. 33 lights up as soon as you press one of the buttons. If the indicator lamp does not light up or flash, this means the battery is exhausted and must be replaced.

Changing the battery ⇒ page 41.

⚠ WARNING

- Always switch off the ignition and take the key with you when leaving the vehicle - even if you only intend to be gone for a short time. This is especially important if children are left in the car. They might otherwise be able to start the engine or use power-operated equipment such as the electric windows - this could lead to injuries.
- Wait for the vehicle to come to a standstill before removing the ignition key from the lock. Otherwise the steering lock could engage suddenly, causing an accident. ■

Remote control key

The remote control will lock and unlock the vehicle without having to insert the key in the lock.

The remote control transmitter and the battery are integrated in the handle of the key. The receiver is in the interior of the vehicle. The maximum range of the remote control depends on various factors. The range is reduced when the battery starts to lose power.

If the receiver has been repaired or replaced, or if a replacement key is used, the system will need re-programming by a qualified workshop. This is necessary so that the receiver can recognise your remote control key.

The remote control keys (which are radio-operated) conform with all relevant requirements for Germany and have been approved by the Federal Approvals Office for Telecommunications of the Federal Republic of Germany. All components are marked in accordance with the current legal requirements. This certification forms the basis for approval for use in other countries.

Personalised remote control key



When you switch off the ignition or lock the vehicle, the settings of various convenience features are automatically stored and assigned individually to the remote control key that is currently in use. The settings stored for the remote control key are then recalled automatically the next time the vehicle is unlocked, the door is opened or the ignition is switched on.

Note

- The remote control key is automatically deactivated when the ignition is switched on.
- The function of the remote control key may be impaired by interference from other nearby radio signals (for example from a mobile telephone or TV transmitter) if these are in the same frequency range. ■

Synchronisation

If the remote control fails to unlock the vehicle, it will be necessary to re-synchronise the system.

- Press the unlock button  on the remote control.
- Use the key to manually unlock the driver's door within 30 seconds.
- Press the unlock  or the lock button .



Replacing the battery for the remote control key

Each remote control key contains a battery which is located in the cover of the key.



Fig. 34 Remote control key. Opening the cover

We recommend having the battery changed by a qualified workshop if required. However, if you decide to change the used battery yourself:

- **Carefully** prise apart the key \Rightarrow fig. 34  and the cover  using a coin.
- Remove cover in the direction of the arrow. 

Doors and windows

- Take the used battery out of the cover.
- Insert the new battery. Make sure that the “+” symbol on the battery is facing downwards. The correct polarity is indicated on the cover.
- After inserting the battery, align the cover and key and press the two parts together.



For the sake of the environment

Used batteries must be disposed of appropriately and must not be discarded with ordinary household waste.



Note

The new battery must be of the same type as the original one. ■

Electronic immobiliser

The immobiliser is designed to prevent unauthorised persons from driving the vehicle.

An electronic chip inside the key automatically deactivates the immobiliser when the ignition is switched on. When the ignition is switched off after coming to a stop the electronic immobiliser is activated automatically.

If an uncoded key is used, **SAFE** will appear continuously in the mileage recorder display.



Note

- The engine can only be started using an original Audi key with the correct code.
- It may not be possible to start the engine with the key if there is another ignition key from a different make of vehicle on the same key ring. ■

Central locking system

Description

The central locking system allows both doors to be locked and unlocked simultaneously.

The central locking system on your vehicle locks and unlocks both doors simultaneously.

The remote control key locks and unlocks the vehicle by means of a radio signal ⇒ *page 43*.

Locking and unlocking the vehicle using the key

In addition to the other functions, you can lock and unlock the vehicle in the normal way by turning the key in the driver's door lock. However, please note that when you unlock the vehicle with the key, this only unlocks the *mechanical* lock on the doors set in the menu display ⇒ *page 24*. In order to switch off the anti-theft alarm, you must insert the key in the ignition lock and switch on the ignition within 15 seconds after opening the driver's door. The alarm will be set off if the ignition is not switched on within 15 seconds.

When you lock the vehicle, this automatically locks both of the doors and activates the anti-theft alarm.

Windows

The windows can be opened or closed together via the central locking system ⇒ *page 43*.

Deadlock mechanism

The central locking system is combined with a **deadlock mechanism**. Once the vehicle has been locked from the outside, the door handles on the inside are deactivated. This makes it more difficult to break into the vehicle.

However, it is also possible to lock the vehicle without activating the deadlock mechanism. ▲

Driver's door lock: Turn the key in the driver's door to the "lock" position twice within 2 seconds.

Automatic locking function (Auto Lock)

The **Auto Lock** function locks all the doors and the luggage lid when the vehicle exceeds a speed of about 15 km/h.

The vehicle is unlocked again automatically when the ignition key is removed. Alternatively, the vehicle can also be unlocked via the central locking switch  or by pulling one of the inside door handles. If desired, you can deactivate the Auto Lock feature in the menu display \Rightarrow page 24 or have it deactivated by a qualified workshop.

Turn signals

All the turn signals will flash as confirmation when the vehicle is locked or unlocked. The turn signals flash twice when the vehicle is unlocked and once when the vehicle is locked, provided that the luggage lid and all the doors are closed. In addition, the interior lights will automatically light up when the vehicle is unlocked and go out when the vehicle is locked, provided that the switches are in the courtesy light position.

WARNING

Do not leave anyone (especially children) in the car if it is locked from the outside and the deadlock mechanism is activated: the doors and windows cannot then be opened from the inside. Locked doors could delay assistance in an emergency, potentially putting lives at risk.

Note

- If the central locking system should fail to work, you can still lock and unlock the driver's door with the key. The passenger's door can be locked manually \Rightarrow page 46.
- The deadlock mechanism and the anti-theft alarm cannot be activated if the central locking is not functioning.

- Never leave any valuable items in the vehicle unattended. Even a locked vehicle is not a safe. ■

Locking and unlocking the vehicle



Fig. 35 Remote control key. Control buttons

Unlocking the vehicle

- Press button **A** once \Rightarrow fig. 35.

Locking the vehicle

- Press button **B** once \Rightarrow .

Unlocking the luggage lid

- Press button **C** for at least one second.

Opening all the windows

- Press and hold button **A** until all windows are open.

Closing all the windows

- Press and hold button **B** until all windows are closed \Rightarrow .

The turn signals will flash twice as confirmation when you unlock the car. The vehicle will be locked again automatically if you do not \blacktriangleright

44 Doors and windows

open one of the doors or the luggage lid within 30 seconds after unlocking the car. This function prevents the vehicle from remaining unlocked if the unlocking button is pressed by mistake.

On vehicles with the **security central locking** feature, you can unlock just the driver's door by pressing button **(A)** once, or the whole vehicle by pressing the button twice.

The turn signals flash once when the vehicle is locked to confirm that the doors and luggage lid are properly locked.

WARNING

- Do not leave anyone (especially children) in the car if it is locked from the outside and the deadlock mechanism is activated: the doors and windows cannot then be opened from the inside. Locked doors could delay assistance in an emergency, potentially putting lives at risk.
- Take care when closing the windows. Careless use of the windows can cause injuries.
- For safety reasons, you should only use the remote control open and close functions within about 2 metres of the vehicle. To avoid injuries, always keep an eye on the windows when pressing the button to close them. The windows stop moving as soon as the button is released.

Note

- The remote control should only be used when the doors and the front lid are closed.
- The remote control should not be used when the vehicle is out of sight.
- The anti-theft alarm can be accidentally activated and the vehicle locked if you press the locking button **(L)** on the remote control inside the vehicle before inserting the key in the ignition. If this should happen by mistake, press the unlocking button **(U)**.

- The convenience open/close function for the windows only works when the "Convenience open" function is activated in the menu display ⇒ page 24. ■

Locking and unlocking the vehicle using the key

If the central locking system should fail to operate, the vehicle can still be locked and unlocked by turning the key in the lock.



Fig. 36 Lock on driver's door

Unlocking

- Turn the key in the driver's door lock to position **(A)** ⇒ fig. 36.

Locking

- Turn the key in the driver's door lock **once** to position **(B)** ⇒ .
- If you turn the key to position **(B)** in the driver's door lock a **second time within 2 seconds**, this will lock the vehicle **without activating the deadlock mechanism**. ▲

**WARNING**

Do not leave anyone (especially children) in the car if it is locked from the outside and the deadlock mechanism is activated: the doors and windows cannot then be opened from the inside. Locked doors could delay assistance in an emergency, potentially putting lives at risk.

**Note**

- The deadlock mechanism and the anti-theft alarm cannot be activated if the central locking is not functioning.
- However, please note that when you unlock the vehicle with the key, this only unlocks the *mechanical* lock on the doors set in the menu display ⇒ [page 24](#).
- Both doors are automatically locked when you lock the vehicle. ■

Central locking switch

The central locking system can be activated using the central locking switch on the driver's door.



Fig. 37 Detail of the driver's door: Central locking switch

Locking the vehicle

- Press the upper switch  ⇒ [fig. 37](#) ⇒ .

Unlocking the vehicle

- Press the lower switch .

Please note the following when you use the central locking switch to lock your vehicle:

- It is not possible to open the doors from the *outside* (for safety reasons, e.g. when stopped at traffic lights).
- The LED in the central locking switch lights up when all the doors and the luggage lid are closed and locked.
- You can open the doors individually from the inside by pulling the inside door handle.
- When the driver's door is open, it cannot be locked by pressing the central locking switch and then closing the door. This helps to prevent you from being locked out of the vehicle. The door has to be locked separately after it has been closed.
- In the event of an accident in which the airbags inflate, doors locked from the inside will be automatically unlocked to facilitate access and assistance.

**WARNING**

The central locking switch is still operative when the ignition is switched off. You can use it to lock both doors automatically. However, since this makes it difficult to enter the car from the outside, you should never leave children unattended in the vehicle. Locked doors could delay assistance in an emergency, potentially putting lives at risk.

**Note**

The central locking switch inside the vehicle will not be operative if the deadlock mechanism has been activated. ■

Locking passenger's door manually

If the central locking system should fail to work at any time, the passenger's door will have to be locked separately.



Fig. 38 Manual locking device on the passenger's door pillar



Fig. 39 Locking the door manually

For this purpose, a manual locking device (only visible when the door is open) is provided on the passenger's door.

- Open the door.
- Pull the cap out of the opening ⇒ fig. 38.
- Insert the key in the slot inside ⇒ fig. 39 and turn it to the right as far as the stop.

- Replace the cap.

Once the door has been closed it can no longer be opened from the outside. The door can be opened from the inside by pulling the door handle. ■

Applies to vehicles with security central locking

Security central locking

The security central locking feature allows the driver's door to be unlocked separately, without unlocking other areas.

Unlocking the driver's door

- Turn the key to the unlock position once.

Unlocking both doors at the same time

- Turn the key to the unlock position twice within 5 seconds.

The deadlock mechanism is immediately deactivated even if just the driver's door is unlocked. ■

Luggage lid

Opening and closing the luggage lid



Fig. 40 Driver's door:
Unlocking the luggage lid



Fig. 41 Luggage lid
unlocked: Release lever

The windscreen wipers must be switched off and the wiper arms must be in contact with the windscreen when the luggage lid is opened. Otherwise the paint may get damaged.

Opening luggage lid

- Press the centre button on the remote control key, or
- Press the unlock switch on the driver's door ⇒ fig. 40.

- Pull the release lever ⇒ fig. 41 in the direction indicated (arrow). This will release the arrester hook.
- Pull the luggage lid up.

Closing luggage lid

- To close the luggage lid, pull it down to overcome the spring pressure.
- Close the luggage lid.
- Press down the luggage lid carefully with both hands until you hear it engage ⇒

WARNING

- For safety reasons the luggage lid must always be completely closed when the vehicle is moving. After closing it always check that it is properly secured. The luggage lid must be flush with the adjacent body panels.
- Should you notice that the luggage lid is not safely secured when the vehicle is moving, stop the vehicle immediately and close the luggage lid properly, otherwise it could cause an accident.

Caution

Make sure that no objects protrude beyond the edges of the storage well otherwise the luggage lid could be damaged.

Note

The door catches/luggage lid warning symbol lights up in the instrument cluster if the luggage lid is not properly closed when the ignition is switched on. ■

Doors and windows

Manual release of the luggage lid

The luggage lid can be released manually if it will not open in the normal way.



Fig. 42 Detail: Manual release

- Fold out the foot rest in the passenger's footwell
⇒ page 190.
- Pull the plastic cord towards you ⇒ fig. 42. ■

Anti-theft alarm system

Description

The anti-theft alarm triggers an alarm if anyone attempts to break into the vehicle.

The anti-theft alarm helps to prevent the vehicle being broken into or stolen. If the system senses interference with the vehicle it triggers an audible and visible alarm.

How is the system switched on (armed)?

The anti-theft alarm system switches on automatically when the vehicle is locked with the remote control or by turning the key in the driver's door (if the door is closed). The system becomes active about 30 seconds after the vehicle is locked.

If you turn the key *twice* to the lock position within one second, the anti-theft warning system is *not* activated.

How is the system switched off?

The anti-theft alarm is only switched off when the vehicle is unlocked **using the remote control**. The vehicle will lock itself again automatically if none of the doors is opened within 60 seconds after pressing the remote control button.

If the vehicle is opened *with the key* on the driver side door, the passenger side door remains locked. The anti-theft alarm is only switched off if the key is inserted into the ignition lock within 15 seconds and the ignition is switched on. Otherwise the system **triggers the alarm**. On some export versions the alarm is already triggered **as soon as** the driver's door is unlocked with the key and opened.

When does the system trigger an alarm?

The anti-theft alarm monitors and protects the following parts of the car:

- Engine compartment (engine lid)
- Luggage compartment
- Doors
- Ignition
- Interior ⇒ page 49

If any of the named areas are entered or tampered with, the alarm will sound.

How is the alarm switched off?

The alarm can be switched off by unlocking the vehicle using the remote control, or by switching on the ignition with the key and thus "disarming" the system. The alarm will also switch itself off when it comes to the end of its cycle. ▲

Turn signals

The turn signals flash briefly when the vehicle is locked to confirm that the doors, the engine lid and the luggage lid are properly closed and locked.

If the turn signals do not flash, check the doors, engine lid and luggage lid to make sure they are properly closed. The turn signals will flash briefly if one of the doors, the luggage lid or the engine lid is closed after the system has been switched on.

Note

- To make sure that the alarm is fully operative when leaving the vehicle, briefly check that all the doors and windows are closed.
- If the vehicle is unlocked at the driver's door using the key, the central locking switch only becomes fully functional after the ignition is switched on.
- The alarm is triggered immediately if one of the battery cables is disconnected while the alarm system is active. ■

Interior monitor

The interior monitor triggers an alarm if it detects movement inside the vehicle.



Fig. 43 Switches for the interior monitor in the door trim (only visible when the driver's door is open)

You should deactivate the interior monitor if there is a possibility that the alarm could be set off, for instance, by a pet or by an object moving about inside the car ⇒ . The tow-away protection function* should be deactivated if the car is being towed or transported (for instance by rail or ship).

Deactivating interior monitor

- Press the switch **(A)** on the door ⇒ fig. 43.
- Then lock the vehicle.

Deactivating the tow-away protection*

- Press the switch **(B)** on the door.
- Then lock the vehicle.

The diode in the switch or will light up when the interior monitor / tow-away protection* function is deactivated. In addition, the diode on the dashboard will light up for about 3 seconds. The diode on the dashboard will flash rapidly for about 3 seconds after the vehicle is locked. There then follows an interval of about 30 seconds before the diode starts flashing slowly.

The interior monitor / tow-away protection* function is automatically switched on again next time the vehicle is locked.

WARNING

Do not leave anyone (especially children) in the car if it is locked from the outside and the deadlock mechanism is activated: the doors and windows cannot then be opened from the inside. Locked doors could delay assistance in an emergency, potentially putting lives at risk. ■

50 Doors and windows

Electric windows

Controls

The driver can operate all the electric windows in the vehicle.



Fig. 44 Detail of the driver's door: Controls



Fig. 45 Switch on front passenger's door

The electric windows are controlled by **two-stage switches**:

Opening the windows

- Press the switch as far as the **first stop** and hold it until the window has moved to the desired position.
- Press the switch briefly **to the second stop**: the window will automatically open all the way.

Closing the windows

- Pull the switch as far as the **first stop** and hold it until the window has moved to the desired position.
- Pull the switch briefly **to the second stop**: the window will automatically close all the way.

WARNING

- Always take the key with you when leaving the vehicle - even if you only intend to be gone for a short time. This is especially important if children are left in the car. They might otherwise be able to start the engine or use power-operated equipment such as the electric windows - this could lead to injuries. The window switches are only deactivated when the driver's door or the front passenger's door is opened.
- Always be careful when closing the windows. Careless use of the electric windows can cause severe injuries.
- When locking the vehicle from the outside, make sure that nobody is inside the vehicle, as the windows cannot be opened from the inside in an emergency.

Note

- When the doors are opened the windows will automatically come down approximately 10 mm.
- You can also open the windows using the remote control key ⇒ *page 43*. ■

Possible malfunctions

The one-touch open and close function will not work if the battery has been temporarily disconnected. The function can be restored as follows:

- Close the window as far as it will go by lifting and holding the window switch.
- Release the switch and then lift it again for one second. This will reactivate the automatic function. ■

Lights and vision

Lights

Switching lights on and off



Fig. 46 Detail of the dashboard: Light switch

Switching on the side lights

- Turn the light switch \Rightarrow fig. 46 to position \Rightarrow ☞. The indicator lamp \Rightarrow ☞ lights up when the side lights are on.

Switching on the dipped or main beam headlights

- Turn the light switch to position \Rightarrow ☞.
- Press the main beam lever forward \Rightarrow page 56.

Switching off the lights

- Turn the light switch to position 0.

The dipped beam headlights will only work with the ignition on. The headlights are switched to side lights while the engine is being started and after the ignition has been switched off.

The daytime running lights are activated when you switch on the ignition if the light switch is in position 0 or AUTO, provided that the daytime running lights function has been activated in the menu display \Rightarrow page 24.

Note

- If the lights are left on after the key has been taken out of the ignition lock, a buzzer sounds when the driver's door is opened.
- The use of the lighting described here is subject to the relevant statutory requirements.
- The headlights and rear lights may mist up temporarily on the inside in cool or damp weather.
 - This is due to the difference in temperature on the inside and the outside of the headlight glass.
 - When the headlights are switched on the surface heated by the light will soon be demisted, however the glass may still be misted up inside, around the edges.
 - This phenomenon has no influence on the life expectancy of the vehicle lights.
- Switch on the headlights when the ambient light starts to fade or in conditions of poor visibility. ■

Applies to vehicles: with automatic headlights

Automatic (sensor-controlled) headlights

If you set the switch to "AUTO", the headlights will come on and switch off automatically according to the ambient light level.



Fig. 47 Detail of the dashboard: Light switch

The automatic headlight setting only activates the dipped beam headlights (not the main beam headlights) ⇒ page 52.

Activating automatic headlights

- Turn the light switch ⇒ fig. 47 to the **AUTO** position.

Deactivating automatic headlights

- Turn the light switch to position **O**.

The symbol in the switch lights up when the switch is in the **AUTO** position.

The dipped beams, side lights, rear lights and number plate lights come on together when the headlights are switched on automatically.

When you are using the automatic headlights you can also operate the main beam headlights; however, please note the following: If

you activate the main beam headlights while using the automatic headlights function (e.g. when driving through a tunnel), but do not deactivate them again, only the dipped beam headlights will come on the next time the lights are automatically switched on. To be able to use the main beam headlights again you must first pull the main beam lever back to the "off" position and then push it forward again to "on".

The side lights, headlights and rear fog light can still be switched on manually in the normal way by using the light switch ⇒ page 52.

Sensors in the mounting for the interior mirror monitor the ambient light level. The headlights will be switched on automatically if the available light drops below a preset value (for instance when driving through a tunnel, etc.). The headlights switch off again automatically when the light level increases ⇒ ⚠.

Malfunction of light sensor

If a malfunction should occur in the light sensor, the symbol  will light up in the display. For safety reasons, the dipped beam headlights will then be switched on permanently when the light switch is set to the **AUTO** position. However, you can still switch the lights on and off in the normal way with the light switch. You should have the light sensor checked by a qualified workshop as soon as possible.

⚠ WARNING

- The automatic headlights are only intended to assist the driver. The driver must always ensure that the headlights are used when required, and may have to switch them on manually when the light conditions or visibility are poor. The light sensors are, for example, not able to detect rain and fog - you should therefore always switch on the headlights  in these conditions and when driving after dark.
- Observe all relevant statutory requirements when using the lighting systems described here.





54 Lights and vision

Note

- When the automatic headlights have been activated, the dipped-beam headlights will go out when the ignition is switched off, and the side lights will go out when the key is taken out.
- Do not attach any stickers to the windscreen in front of the sensor, as this would interfere with the operation of the automatic headlights and the automatic anti-dazzle function for the mirrors. ■

Rear fog light

The light switch can also be used to turn on the rear fog light.

- Do not turn the light switch  ⇒ page 52, fig. 46 to the symbol .
- First turn the light switch  ⇒ page 52, fig. 46 to position .
- Then pull out the light switch to switch on the rear fog light.

The symbol  next to the switch will light up when the rear fog light is on.

Caution

To avoid dazzling the traffic behind you, the rear fog light should only be used in accordance with statutory regulations. ■

Applies to vehicles: with coming home/leaving home function

Coming home/leaving home function

After dark the area around the car is lit up with the aid of the coming home / leaving home function.



Fig. 48 Detail of the dashboard: Coming home / leaving home switch

Activating the functions

- Press the button  ⇒ fig. 48. The diode will be lit in the button.

Deactivating the functions

- Press the button . The diode in the button will go off.

The coming home / leaving home function is controlled by light sensors in the mounting for the rear view mirror. The system will function when the following requirements are met:

- The diode in the button is lit .
- The headlights and the ignition are switched off.
- Dark conditions; the sensors register little or no light.
- The leaving home function is activated in the menu display ⇒ page 24. ▲

Coming home function

When the system is activated and it is dark, the coming home function will illuminate the vehicle and its surroundings by switching on the dipped headlights, rear lights, engine compartment lighting* and number plate lights when the driver's door is opened.

The dipped headlights will stay on for about four minutes as long as one of the doors or the luggage lid is open.

The dipped headlights stay on for about 30 seconds to light up the area in front of the car after all the doors and the luggage lid have been closed.

If required, you can set the time interval to between 0 and 60 seconds in the driver information system (**Lights** menu) ⇒ [page 24](#).

Leaving home function

The dipped headlights and the engine compartment lighting* are switched on when the vehicle is unlocked with the  button on the remote control key if the leaving home function is activated in the menu display ⇒ [page 24](#).

The dipped headlights and the engine compartment lighting* switch off when the driver's door is opened. If the driver's door is not opened, the dipped headlights and the engine compartment lighting* will be switched off when the car automatically locks again ⇒ [page 41](#).



Note

- If you always wish to use the coming home / leaving home function, you can leave it switched on permanently. As the system is controlled via a light sensor, it will only work in dark conditions.
- Permanent use of the coming home / leaving home function, in particular on short journeys, will increase the load on the battery. To make sure the battery is always sufficiently charged, occasionally drive longer distances.
- Observe all relevant statutory requirements when using the lighting systems described here. ■

Instrument lighting

The brightness of the instrument lighting, displays and centre console lighting can be varied as required.



Fig. 49 Instrument lighting

The basic level of brightness for the instrument lighting is adjusted using the left-hand thumbwheel  ⇒ [fig. 49](#).

The lighting of the needles in the instrument dials is regulated by a photo-transistor integrated in the instrument cluster. When the vehicle's lights are switched on, the illumination of the centre console and instruments (needles and dials) is automatically adjusted according to the prevailing light conditions. The driver can also vary the brightness of the illumination manually if required:

With the ignition switched on

When the ignition is on, the basic level of brightness of the needles in the instrument cluster can be adjusted by turning the thumbwheel.

With the vehicle's lights switched on:

When the vehicle's lights are switched on, the brightness of the instrument lighting, displays and centre console lighting can be varied by turning the thumbwheel. ■



Hazard warning lights 

The hazard warning lights are used to make other road users aware of your vehicle in hazardous situations.



Fig. 50 Centre console: Switch for hazard warning lights

- Press the switch  to switch the hazard warning lights on or off \Rightarrow fig. 50.

All four turn signals flash simultaneously when the hazard warning lights are switched on. The two turn signal indicator lamps  and the indicator lamp in the switch  will flash at the same time. The hazard warning lights also work when the ignition is switched off. In an accident in which the airbags are activated, the hazard warning lights are switched on automatically.

Note

You should switch on the hazard warning lights to warn other road users, for instance:

- When reaching the tail end of a traffic jam
- If your vehicle breaks down or there is an emergency
- If your vehicle is being towed away, or if you are towing another vehicle. ■

Turn signal  and main beam lever 

The turn signal and main beam lever also operates the parking lights and the headlight flasher.



Fig. 51 Turn signal and main beam headlight lever

The turn signal and main beam headlight lever has the following functions:

Turn signals 

- Move the lever all the way up \Rightarrow fig. 51 to indicate right, or all the way down to indicate left.
- Move the lever up or down to the point of resistance and hold it there to signal *briefly*, for instance when changing lane.
- Move the lever briefly up or down as far as the point of resistance and release it to signal *three times* with the turn signals. This **one-touch signaling** function must be activated in the menu display \Rightarrow page 24.

Main beam headlights 

- Press the lever forward to switch on the main beams.
- Pull the lever back towards you to switch the main beam headlights off again. ▲





Headlight flasher

- Pull the lever towards the steering wheel to operate the flasher.

Parking lights

- Switch off the ignition.
- Move the lever up or down to turn on the right or left-hand parking lights respectively.

Notes on these functions

- The *turn signals* only work when the ignition is switched on. The corresponding indicator lamp  or  flashes in the instrument cluster ⇒ *page 15*.
- The turn signals are cancelled automatically when the steering wheel is returned to the straight-ahead position.
- The *main beam headlights* can only be switched on if the dipped beam headlights are already on. The main beam headlight indicator lamp  then comes on in the instrument cluster.
- The *headlight flasher* comes on for as long as you pull the lever – even if no other lights are switched on. The main beam headlight indicator lamp  then comes on in the instrument cluster.
- When the *parking lights* are switched on, the headlight and the rear light on one side of the car light up with reduced intensity. The parking lights will only work with the ignition off. A warning buzzer will sound for as long as the driver's door is open.

Caution

Do not use the main beam headlights or the headlight flasher if this would dazzle oncoming traffic. ■

Interior lights

Interior lights

The interior light also incorporates the reading lights for the driver and front passenger.

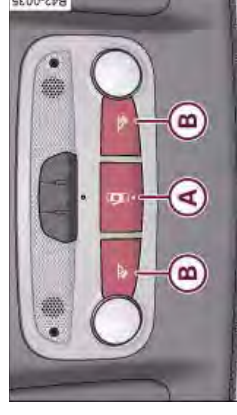

Fig. 52 Detail of headliner: Interior lights

Activating the courtesy light function

- Press switch **(A)**. The diode in the switch will light up.

Deactivating the courtesy light function

- Press switch **(A)**. The diode in the switch will go out.

Front reading lights

- Press the switches **(B)** to switch the left and right reading lights on and off.

If the switch is in the courtesy light position, the interior light comes on automatically when the vehicle is unlocked or the doors are opened. The light also comes on when the key is pulled out of the ignition. It goes out approximately 30 seconds after the doors are closed. The interior light is switched off immediately when the vehicle is locked or when the ignition is switched on. ▲

58 Lights and vision

If a door is left open, the light is switched off after about 10 minutes to prevent the battery from running flat.

The brightness of the light is automatically adjusted by a dimmer when it is switched on. ■

Luggage compartment light

The light is on the right of the luggage compartment.

The light switches on automatically when the luggage lid is opened. The luggage compartment light is switched off automatically if the luggage lid is left open for more than about 10 minutes. ■

Applies to vehicles: with engine compartment lighting

Engine compartment lighting

The lighting is on both sides of the engine compartment interior.

The lighting is automatically switched on when the coming home/leaving home function* is activated ⇒ [page 54](#). ■

Clear vision

Sun visors

The sun visors can improve visibility and contribute to safety.



Fig. 53 Sun visor

There are covers on the make-up mirrors in the sun visors. ■

Windscreen wipers

Windscreen wipers

The windscreen wiper lever controls the windscreen wipers and the automatic wash and wipe.



Fig. 54 Windscreen wiper lever

The windscreen wiper lever \Rightarrow fig. 54 has the following settings:

Brief wipe

- Move the lever down to position ① to give the windscreen a *brief* wipe.

Intermittent wipe (activating light sensor/ rain sensor*)

- Move the lever up to the stop ②.
- Move the control **A** to set the wiper intervals or the sensitivity of the light sensor/ rain sensor*.

Slow wiper speed

- Move the lever up to the stop ③.

Fast wiper speed

- Move the lever up to the stop ④.

Automatic wash and wipe

- Pull the lever to position ⑤.
- Release the lever again. The washer will stop and the wipers will keep running for approximately 4 seconds. The number of wipe cycles varies according to the length of time the lever is pulled.

Switching off the wipers

- Move the lever to the "off" position ⑥.

Lifting the wiper arms

- Do **not** lift the wiper arms away from the windscreen when they are in their normal park position; this could damage the paintwork on the luggage lid.
- In icy conditions, check that the wiper blades are not frozen to the windscreen.
- Place the wipers in the "service position" \Rightarrow page 61.

The washers and wipers will only work when the ignition is switched on.

To reduce the sensitivity level of the light sensor/ rain sensor* move control **A** downwards. To increase the sensitivity level of the light sensor/ rain sensor move the control upwards. If you have selected a high sensitivity level for the rain sensor the windscreen wipers will react sooner to any moisture on the windscreen. The wiper intervals in the intermittent wipe setting are also varied automatically according to the road speed (in addition to the sensitivity setting). If you stop briefly, e.g. at traffic lights, the wiper speed will automatically be reduced by one level. \blacktriangle

The windshield washer jets are heated when the ignition is switched on.

When the lights are switched on you should only pull the lever briefly to wash the windshield, otherwise the headlight washers will also be activated. This will use an unnecessary amount of fluid from the reservoir.

WARNING

- **Poor visibility can cause accidents. Always ensure that the wiper blades are in good condition** ⇒ page 62, "Changing wiper blades".
- **The light sensor/ rain sensor* is only intended to assist the driver. The driver is still obliged to manually operate the windshield wipers and the lights as required depending on visibility.**
- **Do not use water-repellent coatings on the windshield. In bad visibility conditions such as light rain, low sun or when driving at night these coatings can cause increased dazzle, which is a serious safety hazard. Such coatings can also cause the wiper blades to judder.**

Caution

- In icy conditions, always check that the wiper blades are not frozen to the glass before using the wiper for the first time. If you switch on the wipers when the wiper blades are frozen to the glass, this could damage both the wiper blades and the wiper motor.
- Make sure you switch off the windshield wiper system (lever in position "0") before you use an automatic car wash. This will avoid inadvertent triggering of the wipers and possible damage to the wiper system.

Note

- Check that the washer fluid reservoir is full before starting a long journey. Filling the reservoir ⇒ page 164.

- Worn or dirty wiper blades can cause smearing on the glass which can also impair the effectiveness of the light sensor/ rain sensor*. Please check the wiper blades regularly.
- If you leave the windshield wiper lever set to the intermittent wipe function when the ignition is switched off, the light sensor/ rain sensor* will not be activated until you reach a road speed of at least 6 km/h.
- Applies to vehicles with light sensor/ rain sensor: If the windshield wipers have been activated manually and it is raining, the automatic headlights* will come on ⇒ page 53, "Automatic (sensor-controlled) headlights". In the daytime the headlights will automatically go off again once the wipers are switched off. The automatic headlights* function is only available if the light switch is in the "AUTO" position ⇒ page 53, fig. 47. ■

Headlight washer system

With the lights switched on, operate the automatic windshield wash and wipe ⇒ page 59, fig. 54 , and keep the lever pulled towards you for at least 1 second.

The headlight washer jets come out of the bumper automatically (under water pressure).

Clean off stubborn dirt (insects, etc.) from the lenses at regular intervals, for instance when stopping for fuel.

To ensure that the system works properly in winter, keep the nozzle holders free of snow and remove any ice with a de-icer spray. ■

Service position

The wiper blades can only be replaced when the wiper arms are in the service position.



Fig. 55 Windscreen wiper lever

The windscreen wipers will only function if the luggage lid is completely closed.

Moving the wiper blades into the service position

- In icy conditions, check that the wiper blades are not frozen to the windscreen.
- Switch on the ignition.
- Move the windscreen wiper lever to position **0**.
- Press the **[Reset]** button repeatedly until the **DISPLAY TYPE** menu appears in the driver information system display.
- Use the rocker switch and the **[Reset]** button to select **SET > WIPERS > FRONT > SERVICE POSITION ON**. The wiper arms will move into the service position.

Returning the wiper blades to their normal park position

- Make sure that the wiper blades are resting on the windscreen.
- Switch the ignition on and push the windscreen wiper lever \Rightarrow fig. 55 from position **0** to **1**. The wiper arms will return to their normal park position.

! Caution

Never move the vehicle with the wiper arms in a raised position as they are automatically moved back to their normal park position above a speed of 6 km/h. The paintwork on the luggage lid may be damaged as a result.

i Note

- You can also use the service position, for example, if you want to fix a cover over the windscreen in the winter to keep it clear of ice.
- The service position is automatically set to **off** when you operate the windscreen wiper lever or the road speed exceeds 6 km/h. ■

Changing wiper blades

Good wiper blades are essential for clear vision.

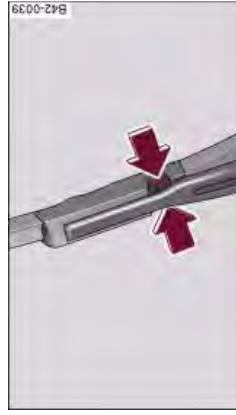

Fig. 56 Releasing the wiper blades



Fig. 57 Removing the wiper blades

Taking off the wiper blade

- Place the wipers in the service position ⇒ page 61.
- Lift the wiper arm away from the glass.
- Press both sides of the plastic retainer at the top end of the wiper arm together in the direction of the arrows ⇒ fig. 56.
- Now twist the wiper blade off the wiper arm in the direction of the arrow **A** ⇒ fig. 57.

- Lift the wiper blade off in direction of the arrow **B**.

Fitting the wiper blade

- Fit the plastic cap of the wiper blade onto the end of the wiper arm (in **opposite** direction of arrow **B** ⇒ fig. 57).
- Make sure you hear the retainer click into place on the wiper arm.
- Fold the wiper arm back down onto the glass.
- Switch the ignition on and briefly press the windscreen wiper lever downwards ⇒ page 61, fig. 55. The wipers will return to their normal park position.

WARNING

- To prevent smearing on the glass, the wiper blades should be cleaned regularly using a window cleaner solution. If the wiper blades are very dirty (insects etc.), they should be cleaned using a sponge or cloth – bad visibility can cause accidents.
- For safety, the wiper blades should be changed once or twice a year.

Caution

The ignition must not be switched on while the front wiper arms are in a raised position. The wipers would otherwise return to their park position when you operate the windscreen wiper lever and damage the paintwork on the luggage lid.

Note

The windscreen wiper blades differ in length, the wiper blade on the driver's side is the shorter of the two. ■

Rear-view mirrors

Manual anti-dazzle adjustment

Normal setting

- Push the lever at the bottom of the mirror away from you.

Anti-dazzle setting

- Pull the lever at the bottom of the mirror towards you. ■

Applies to vehicles: with automatic anti-dazzle adjustment for interior mirror

Automatic anti-dazzle interior mirror

The automatic anti-dazzle function can be switched on and off as desired.

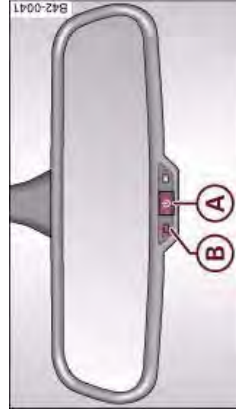

Fig. 58 Anti-dazzle interior mirror: Indicator lamp and on/off switch

Switching off anti-dazzle function

- Press button (A) ⇒ fig. 58 - the indicator lamp (B) will go out.

Switching on anti-dazzle function

- Press button (A) ⇒ fig. 58 - the indicator lamp (B) will light up.

Anti-dazzle function

The anti-dazzle function is activated every time the ignition is switched on. The green indicator lamp lights up in the mirror housing.

When the anti-dazzle function is activated the interior mirror will darken *automatically* according to the amount of light it receives (for example from the headlights of a vehicle behind). The mirror will **not** darken automatically:

- when the interior lighting is switched on
- when reverse gear is engaged

Sensors for automatic headlights

When the light switch is set to the **AUTO** position the dipped beam headlights are switched on and off automatically according to the ambient light level with the aid of the sensors located in the mirror ⇒ page 53.

WARNING

Electrolyte fluid can leak from a broken mirror. This fluid can cause irritation to the skin, eyes, and respiratory organs. Wash thoroughly with clean water should you come into contact with this fluid. Seek medical assistance if needed.

Caution

Electrolyte fluid leaking from a broken mirror can cause damage to plastic surfaces. Use a sponge or similar to remove the fluid as soon as possible.

Note

- If you switch off the anti-dazzle function for the interior mirror, this will also deactivate the anti-dazzle function* for the exterior mirrors. ▲

64 Lights and vision

- The automatic anti-dazzle function will only work properly if there are no objects preventing light from reaching the interior mirror. **(A)**
- Do not attach any stickers to the windscreens in front of the sensors, as this would interfere with the operation of the automatic headlights and the automatic anti-dazzle function for the mirror. ■

Exterior mirrors

The exterior mirrors are adjusted electrically.

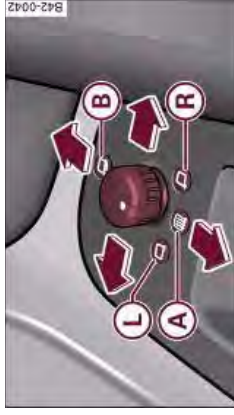

Fig. 59 Detail of the armrest: Adjuster knob

Adjusting exterior mirrors

- Turn the adjuster knob to position **(L)** (left exterior mirror) or position **(R)** (right exterior mirror) ⇒ fig. 59.
- Move the knob as required to adjust the exterior mirror for a good rearward view.

Heated mirrors

- Turn the knob to position **(A)**.

Retracting both exterior mirrors*

- Turn the knob to position **(B)**.

The mirrors are heated depending on the outside temperature until the ignition is switched off, even if the knob is no longer in position **(A)**.
It may be advisable to retract* the exterior mirrors to protect them when parking or when driving through tight spaces.

Caution

- Convex or wide-angle exterior mirrors give a larger field of vision. However, they also make objects appear further away than they actually are. For this reason, you should not rely on these mirrors for judging the distance of vehicles behind.
- If one of the mirror housings is knocked out of position (e.g. when parking), the mirrors must first be fully retracted with the electric control. Do not readjust the mirror housing by hand, as this will interfere with the mirror adjuster function.

Note

If the electrical adjustment should ever fail to operate, the mirrors can be adjusted by hand by lightly pressing the edge of the mirror glass. ■

Applies to vehicles: with automatic anti-dazzle adjustment for exterior mirrors

Automatic anti-dazzle adjustment for exterior mirrors

The exterior mirrors darken together with the automatically adjusting interior mirror. When the ignition is on, the mirrors will darken automatically according to the amount of light received (for example from the headlights of a vehicle behind).

When the interior lights are switched on, or when reverse gear is engaged, the mirrors revert to their original (i.e. not darkened) condition. ▲



WARNING
Electrolyte fluid can leak from a broken mirror. This fluid can cause irritation to the skin, eyes, and respiratory organs. Wash thoroughly with clean water should you come into contact with this fluid. Seek medical assistance if needed.



Caution
Electrolyte fluid leaking from a broken mirror can cause damage to the paintwork or plastic surfaces. Use a sponge or similar to remove the fluid as soon as possible.



- Note**
- If you switch off the automatic anti-dazzle function for the interior mirror, this will also deactivate the automatic anti-dazzle function for the exterior mirrors.
 - The automatic anti-dazzle function will only work properly if there are no objects preventing light from reaching the interior mirror. ■

Digital compass

Applies to vehicles: with digital compass

Activating and deactivating the compass

The compass direction will appear in the mirror.

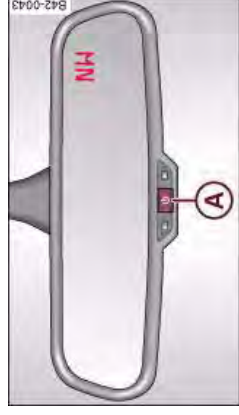

Fig. 60 Interior mirror: activated digital compass

- To switch the compass on and off, press and hold button **A** until the compass display in the mirror appears or disappears.

The digital compass only works when the ignition is on. The points of the compass are displayed as follows: **N** (North), **NE** (North East), **E** (East), **SE** (South East), **S** (South), **SW** (South West), **W** (West), **NW** (North West).



Note

To avoid inaccurate compass readings, do not hold any remote controls or other electrical devices or metal objects near the interior mirror. ■

Applies to vehicles: with digital compass

Setting the correct compass calibration zone

The correct compass calibration zone must first be set before the compass can give an accurate reading.



Fig. 61 Map of compass calibration zones

- Press and hold button **(A)** ⇒ page 65, fig. 60 until the currently set zone number is displayed on the interior mirror.
- Press button **(A)** repeatedly until the correct zone number appears. The adjustment mode will be ended automatically after a few seconds. ■

Applies to vehicles: with digital compass

Calibrating compass

The compass must be re-calibrated if the display is incorrect or inaccurate.

- Press and hold button **(A)** until the letter **C** appears in the interior mirror.
- Drive in a circle at a speed of about 10 km/h until a point of the compass is displayed in the interior mirror.

! WARNING

Calibrate your compass at a location where there is no traffic so that you do not endanger yourself or other road users (accident risk). ■

Seats and storage

Manually adjustable front seats

Applies to vehicles: with manual seat adjustment

Seat adjuster controls

There are several seat adjustment functions for your comfort and convenience

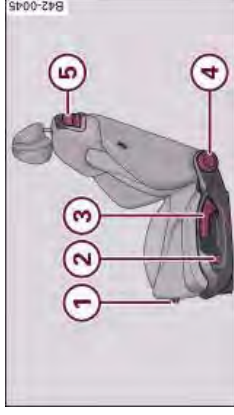

Fig. 62 Adjuster controls on driver's seat

Some of the controls shown are only fitted on certain models or are optional extras.

Adjuster controls

- ① Moves seat backwards or forwards
- ② Adjusts lumbar support*
- ③ Adjusts seat height
- ④ Adjusts backrest angle
- ⑤ Unlocks backrest ■

Applies to vehicles: with manual seat adjustment

Seat adjustment

It is possible to adjust the position, angle and shape of the seat so that you can travel in a safe and comfortable sitting position.

Before adjusting your seat, please read and observe the warnings ⇒ .

Moving seat backwards or forwards

- Lift the lever ① ⇒ fig. 62 and move the seat to the desired position.
- Then release the lever ① and move the seat further until the catch engages.

Adjusting contour of lumbar support*

- Press the front or rear part of the adjuster switch ② to increase or decrease the curvature of the lumbar support as required.

Adjusting height of lumbar support*

- Press the top or bottom part of the adjuster switch ② to move the lumbar support upwards or downwards as required.

Adjusting seat height

- Pull the lever ③ up or down.

Adjusting the backrest angle

- Lean forwards to take your weight off the backrest. ▶

Seats and storage

- Turn the adjuster wheel (4) to set the angle of the backrest as required.

Unlocking backrest

- Push the handle (5) upwards.
- Fold the backrest forwards

! WARNING

- Never adjust the driver's seat when the vehicle is moving - this could lead to an accident.
- Be careful when adjusting the seat angle. Careless or uncontrolled use of the seat adjustment can cause injuries.
- Do not drive with the backrests of the front seats reclined too far as otherwise the seat belt and airbag could fail to restrain the wearer properly in an accident, possibly leading to injury.
- For safety reasons the front seat backrests must be locked while driving. ■

Electrically adjustable front seats

Applies to vehicles: with electric seat adjustment

Seat adjuster controls

The arrangement of the switches corresponds with the design of the seats.

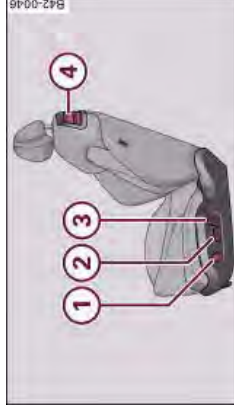

Fig. 63 Front seat: Adjuster controls

The adjustment switches for the seat and backrest correspond with the design of the seat. The seats can be adjusted simply by pressing the corresponding switch in the required direction.

Adjuster controls

- 1 Adjusts lumbar support
- 2 Adjusts seat height and moves seat backwards or forwards
- 3 Adjusts backrest angle
- 4 Unlocks backrest ■

Applies to vehicles: with electric seat adjustment

Seat adjustment

You can use the electrical adjustment to set the position, angle and shape of the seat so that you can travel in a safe and comfortable sitting position.

Before adjusting your seat, please read and observe the warnings ⇒ .

Adjusting contour of lumbar support*

- Press the front or rear part of the adjuster switch  ⇒ page 68, fig. 63 to increase or decrease the curvature of the lumbar support as required.

Adjusting height of lumbar support*

- Press the top or bottom part of the adjuster switch  to move the lumbar support upwards or downwards as required.

Moving seat backwards or forwards

- Press the switch  forwards or backwards.

Adjusting seat height

- Press the switch  up or down.

Raising/lowering seat at front

- Press the front of switch  up or down.

Raising/lowering seat at rear

- Press the rear of switch  up or down.

Adjusting the backrest angle

- Press the switch  forwards or backwards.

Unlocking backrest

- Push the handle  upwards.
- Fold the backrest forwards

WARNING

- Never adjust the driver's seat when the vehicle is moving - this could lead to an accident.
- The electrical seat adjustment also works when the ignition is off and when the key is not in the ignition. To avoid accidental injuries, never leave children unattended in the vehicle.
- Be careful when adjusting the seat height. Careless or uncontrolled use of the height adjustment can cause injuries.
- Do not drive with the backrests of the front seats reclined too far as otherwise the seat belt and airbag could fail to restrain the wearer properly in an accident, possibly leading to injury.
- For safety reasons the front seat backrests must be locked while driving. ■

Bucket seats

Applies to vehicles: with bucket seats

Seat adjuster controls

The bucket seat has several adjustment functions.

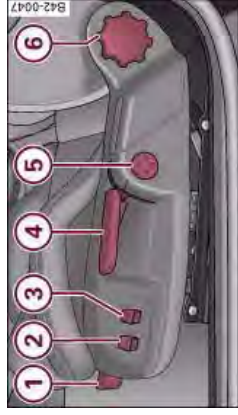

Fig. 64 Adjuster controls on driver's seat

Adjuster controls

- ① Moves seat backwards or forwards
- ② Inflates and deflates side padding
- ③ Inflates and deflates backrest side padding
- ④ Adjusts seat height
- ⑤ Adjusts lumbar support
- ⑥ Adjusts backrest angle ■

Applies to vehicles: with bucket seats

Seat adjustment

You can use the electrical adjustment to set the position, angle and shape of the seat so that you can travel in a safe and comfortable sitting position.

Before adjusting your seat, please read and observe the warnings ⇒ ⚠.

Moving seat backwards or forwards

- Lift the lever ① ⇒ fig. 64 and move the seat to the desired position.
- Then release the lever ① and move the seat further until the catch engages.

Inflating and deflating side padding

- Press the button ②.

Inflating and deflating backrest side padding

- Press the button ③.

Adjusting seat height

- Pull the lever ④ up or down.

Reinforcing top section of backrest

- Press the top of the adjuster control ⑤.

Reinforcing bottom section of backrest

- Press the bottom of the adjuster control ⑤.

Reinforcing both sections of backrest

- Press the front of the adjuster control ⑤.

Returning backrest sections to their "normal" positions

- Press the rear of the adjuster control ⑤.

Adjusting the backrest angle

- Lean forwards to take your weight off the backrest. ▲

- Turn the adjuster wheel (6) to set the angle of the backrest as required.

Unlocking backrest

- Press one of the two levers (4) ⇒ page 68, fig. 63 upwards and fold down the backrest.

! WARNING

- Never adjust the driver's seat when the vehicle is moving - this could lead to an accident.
- The electrical seat adjustment also works when the ignition is off and when the key is not in the ignition. To avoid accidental injuries, never leave children unattended in the vehicle.
- Be careful when adjusting the seat height. Careless or uncontrolled use of the seat adjustment can cause injuries.
- Do not drive with the backrests of the front seats reclined too far as otherwise the seat belt and airbag could fail to restrain the wearer properly in an accident, possibly leading to injury.
- For safety reasons the front seat backrests must be locked while driving. ■

Head restraints

Front head restraints

In combination with properly worn seat belts, the head restraints offer effective protection. However, they must always be properly adjusted to suit the height of the occupant.

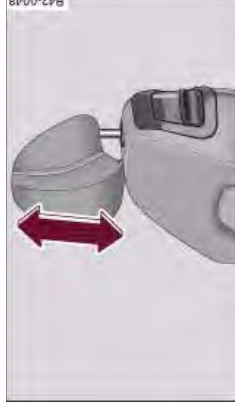

Fig. 65 Head restraint

- Take hold of the sides of the head restraint with both hands.
- Adjust the head restraint so that the top of the head restraint is level with the top of your head.

The height of the head restraints is adjustable. They should be set to suit the height of the occupant. In combination with the seat belts, the head restraints offer effective protection, provided they are properly adjusted. ■

72 Seats and storage

Cup holders



Fig. 66 Cup holders

WARNING

- Do not put any hot drinks in the cup holders while the vehicle is moving. You could be scalded if the hot liquid is spilt.
- Do not use hard china cups or glasses. These could cause injury in the event of an accident.

Caution

You should avoid putting open drinks containers in the cup holders. The drinks could otherwise spill over and cause damage to e.g. the electrical equipment or the seat covers. ■

Ashtray

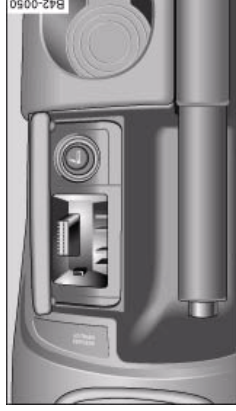

Fig. 67 Centre console:
Ashtray open

Opening ashtray

- Lift the cover.

Removing ashtray

- Open the cover all the way to the right.
- Take out the ashtray.

Inserting ashtray

- Insert the ashtray and press it into its mountings.

WARNING

Never put waste paper in the ashtray, as this could cause a fire. ■

Cigarette lighter and electrical socket

The 12 Volt socket for the cigarette lighter can also be used as a power source for other electrical appliances.

The cigarette lighter and electrical socket only work when the ignition is on. ▲

Using cigarette lighter

- Open the ashtray cover to access the cigarette lighter
⇒ page 72.
- Press in the cigarette lighter knob.
- Wait for the lighter to spring out.
- Pull out the cigarette lighter immediately.
- Use the glowing heater element of the cigarette lighter to light your cigarette.
- Put the cigarette lighter back in its socket.

Operating electrical socket

- Open the cover to access the cigarette lighter.
- Take out the cigarette lighter.
- Insert the plug of the electrical appliance into the cigarette lighter socket.

The cigarette lighter employs a standard 12 Volt socket which can also be used as a power source for electrical appliances. The appliances connected to the socket must not exceed a power rating of 100 W.



WARNING

Take care when using the cigarette lighter. Carelessness or negligence when using the cigarette lighter can cause burns.



Caution

Always use the correct type of plugs to avoid damaging the sockets.



Note

Using electrical appliances with the engine switched off will drain the battery. ■

Storage compartments

Glove box

The lockable glove box is equipped with a light.



Fig. 68 Glove box

Opening glove box

- Pull the catch on the lid in the direction indicated (arrow)
⇒ fig. 68 and open the lid.

Closing glove box

- Close the lid and push it in until it engages.

If the side lights or headlights are switched on, the light in the glove box comes on when the glove box is opened. You will find a compartment for (sun)glasses in the lid.

The glove box has a standard 12 Volt socket which can also be used as a power source for electrical appliances. The appliances

connected to the socket must not exceed a power rating of 100 W.
The socket will only work when the ignition is switched on.



WARNING

To avoid the risk of injuries, always keep the glove box lid closed when driving. ■

Applies to vehicles with storage compartments in the front seats

Storage compartments in the front seats

There is a fold-out drawer in the front part of each front seat.

Opening

- Pull the handle to open the compartment.

Closing

- Close the lid and push it in until it engages.



Note

The storage compartment will hold a maximum weight of 1 kg. ■

Heating and cooling

Air conditioner

Controls

The air conditioner is designed to keep the passenger compartment at the temperature you find most comfortable at all times of the year.



Fig. 69 Air conditioner controls

Recommended settings:

- Turn the control ⇒ fig. 69 ② to the right to switch the air conditioner on.
- Set the temperature to 22 °C (72 °F).
- Press the **(AUTO)** button ⇒ fig. 69.

This setting quickly provides a comfortable temperature inside the vehicle. If necessary it can be changed to suit individual preferences or particular circumstances.

The air conditioner provides heating and ventilation and also cools and dehumidifies the air inside the vehicle.

The air conditioner is fully automatic, and will maintain the desired temperature at a constant level. To achieve this, the temperature of the air supplied to the interior, the blower speed (volume of air delivery) and the air distribution are regulated automatically. The system also allows for the effect of strong sunlight, so there is no need for manual adjustment. For these reasons it is advisable to use the **automatic mode** for the comfort of all the passengers in virtually all conditions throughout the year ⇒ page 78.

Please note:

The humidity of the air is automatically reduced when the system cools the interior of the vehicle. This helps to prevent condensation on the windows. The air conditioner (compressor) will be switched off automatically at low outside temperatures (below zero) and will no longer dehumidify the air inside the vehicle.

If the humidity and temperature outside the vehicle are high, **condensation** can drip off the evaporator in the air cooling system and form a pool underneath the vehicle. This is normal and does not indicate a leak.

If the outside temperature is low, the blower normally only switches to a higher speed once the coolant has warmed up sufficiently (this does not apply to the defrost setting).

In order to achieve maximum engine power, the air conditioner compressor is temporarily switched off when pulling away from a standstill with full throttle. ▲

Heating and cooling

The compressor also switches off if the coolant temperature is excessively high, to ensure adequate engine cooling under extreme loads.

The functions can be set by turning the rotary control and are switched on and off by briefly pressing the buttons. The LEDs in the buttons light up when the function is switched on.

Buttons	Function	Page
Rotary control ①	Temperature selection	⇒ page 76
Rotary control ② 	Switches air conditioner on/off Blower	⇒ page 77
Rotary control ③ 	Air distribution	⇒ page 77
	Defrosting windows	⇒ page 78
	Heated rear window	⇒ page 79
	Seat heating* (driver's side/front passenger's side)	⇒ page 80
	Air recirculation mode	⇒ page 78
	Switching the air conditioner on	⇒ page 79

Pollution filter

The pollution filter (a particle filter) serves as a barrier against impurities in the outside air, including dust and pollen. The air is also filtered when the air recirculation mode is activated.

For the air conditioner to work with maximum efficiency, the pollution filter element must be replaced at the intervals specified in the Service Schedule.

If the vehicle is driven in areas with a high level of air pollution and the filter is no longer fully effective, it may be necessary to change the filter element more frequently.



WARNING
For safety reasons it is important that all the windows are kept free of ice, snow and condensation. These can cause poor visibility and lead to an accident. Please familiarise yourself with the operating controls for the air conditioner, including the demist/defrost functions for the windows.



Caution

- If you suspect that the air conditioner is damaged, switch it off to prevent further damage and have the system checked by a qualified workshop.
- Repairs to the air conditioning system require specialist knowledge and special tools. For this reason, please contact a qualified workshop if the system is not working properly.



Note

- Keep the air intake slots in front of the windscreen clear of snow, ice and leaves to ensure unimpaired heating and cooling, and to prevent the windows misting over.
- The air conditioner operates most effectively with the windows closed. However, if the vehicle has heated up after standing in the sun for some time, the air inside can be cooled more quickly by opening the windows for a short time. ■

Temperature selection

- Turn the rotary control ① ⇒ page 75, fig. 69 to the required temperature setting.

Turn the rotary control to the left to reduce the temperature. Turn the rotary control to the right to increase the temperature. There are several intermediate positions, allowing you to adjust the temperature as required. ■

Switching air conditioner on or off

Switching air conditioner on or off

- Turn the control ② ⇒ page 75, fig. 69 clockwise to switch the air conditioner on. The diode next to the word OFF will go out.
- Turn the control ② ⇒ page 75, fig. 69 anti-clockwise to switch the air conditioner off. The diode next to the word OFF will light up.

Regulating the blower speed

- Turn the control ② ⇒ page 75, fig. 69 to the desired setting for the blower speed (amount of air to be delivered).

In automatic mode, the air conditioning system automatically regulates the blower speed according to the interior temperature. However, you can also adjust the blower speed manually.

Note

The blower speed will automatically be adjusted if the difference between the selected temperature and the actual temperature in the vehicle is too high. This ensures that the selected temperature is reached as quickly as possible. ■

Air distribution

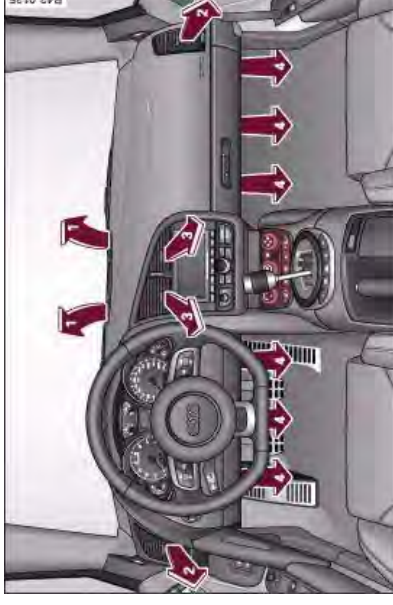













Fig. 70 Dashboard: Location of air outlets

- Turn the rotary control ③ ⇒ page 75, fig. 69 to the desired setting.
- The outlets can be opened and closed by turning the adjustment ring.
- The direction of air delivery from these outlets can be adjusted horizontally and vertically using the adjuster in the centre of each outlet grille.

Air distribution:

- In position  the air will flow only to the windows. Air outlets ① and ② will be opened. For maximum defrosting effect on the side windows in the driver's door and front passenger's door the outlets ② should be directed at the side windows. ▲

Heating and cooling



- In position  the air will flow only to the driver/front passenger. Air outlets  and  will be opened.
 - In position  the air will flow only to the footwells. Air outlets ,  and  will be opened.
 - In position  the air will flow only to the windows and the footwells. Air outlets ,  and  will be opened.
- In addition to this there are several other possible combinations (using intermediate positions), allowing you to adjust the air distribution to suit individual requirements.

Note

When the air conditioner is operating in the cooling mode, the air should be directed mainly to outlets  and . To ensure adequate cooling effect, you should not close these outlets completely. ■

Defrosting

The windshield and side windows are defrosted or demisted as quickly as possible.

- To switch on, press the  button ⇒ page 75, fig. 69.
- To switch off, press the  button again, or press the  button.

The temperature is regulated automatically. The air output is increased to maximum and most of the air comes out of outlets 1 ⇒ page 77.

A small, residual amount of air will emerge from outlets 2, if they are open ⇒ page 77.

The air recirculation mode is switched off when the  button is pressed. ■

Automatic mode

Standard operating mode for all seasons.

Switching on automatic mode



- Set the desired temperature.
- Press the  button ⇒ page 75, fig. 69.

The automatic mode maintains a constant temperature inside the vehicle and dehumidifies the air. Air temperature, air delivery and air distribution are regulated automatically to reach the desired interior temperature as quickly as possible, and then to maintain this temperature. The system automatically compensates for any variations in the outside temperature and for the effect of direct sunlight. ■

Air recirculation mode

The air recirculation setting prevents fumes etc. from entering the interior.

Switching on the air recirculation mode

- Press the  button ⇒ page 75, fig. 69, ⇒ .

Switching off the air recirculation mode

- Press the  button again, or
- Press the  button, or
- Press the  button.

In this setting, the air is drawn from the interior of the vehicle, filtered and continuously recirculated. We recommend using the air recirculation mode for a brief period in the following circumstances ⇒ :

When driving through a tunnel or in queues of traffic, to prevent fumes entering the interior of the vehicle.



WARNING

For reasons of safety you should not leave the air recirculation switched on for too long. This mode prevents fresh air from entering the vehicle, so the windows can mist over if the air cooling is switched off. Bad visibility can cause an accident. ■

AC mode

Activating the AC mode

- Press the  button ⇒ *page 75*, fig. 69.

Deactivating the AC mode

- Press the  button again.

In the AC mode, the air cooling system is switched on and the heating and ventilation are regulated automatically.



Note

If the LED in the AC button should continue to light up when the AC mode has been switched off (i.e. the air conditioner has been switched off) this is due to a defect in one of the air conditioner components. If a malfunction should occur, please contact a qualified workshop. ■

Economical operation of the air conditioner

Economical operation of the air conditioner will help to save fuel.

When the air conditioner is operating in the cooling mode it reduces engine power and increases fuel consumption. To ensure that the cooling mode is activated only when really necessary, please note the following points:

- Switch the AC mode off if you wish to save fuel.
- Switch the AC mode off if you decide to open the windows while driving.
- If the vehicle has heated up after standing in the sun, open the windows and doors for a short time to cool the vehicle.



For the sake of the environment

By saving fuel you also reduce the amount of pollutants emitted from your vehicle. ■

Rear window heating

The rear window heating helps to demist the rear window.

- Press the  button ⇒ *page 75*, fig. 69 to switch the rear window heating on or off.

The rear window heating only works when the engine is running. An indicator lamp in the button lights up when the rear window heater is switched on.

The rear window heating switches off automatically after about 10 minutes. ▲

 **For the sake of the environment**

Switch off the heated rear window manually as soon as the rear window is clear. By saving electrical power you can also save fuel. ■

Applies to vehicles: with seat heating

Seat heating  

The seat cushions and backrests of the front seats can be heated electrically.

- Press the button for seat heating   ⇒ *page 75, fig. 69* to set the desired seat temperature.

Possible settings range from 1 to 3. The selected seat heating setting is indicated by LEDs above the button.

 **Caution**

To avoid damaging the heating elements of the seat heating, please do not kneel on the seat or apply sharp pressure at a single point. ■

Driving

Steering

Adjusting the steering wheel position

The height and reach of the steering wheel can be adjusted as required to suit the driver.

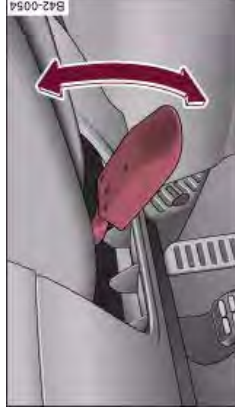

Fig. 71 Lever beneath steering column

- Push the lever ⇒ fig. 71 down ⇒ ⚠.
- Move the steering wheel to the desired position.
- Then push the lever towards the steering column until the catch engages.

⚠ WARNING

- Never adjust the position of the steering wheel when the vehicle is moving - this could cause an accident.
- For safety reasons, the lever must be securely engaged in its top position to prevent the steering wheel from accidentally changing position while driving, which could cause an accident. ■

Ignition lock

Ignition lock

The ignition key is used to start and switch off the engine.



Fig. 72 Ignition key positions

Ignition off ①

In position ① ⇒ fig. 72 the ignition and the engine are switched off, and the steering wheel lock can be engaged.

To engage the steering wheel lock, take out the key and turn the wheel until you hear the pin engage. You should always engage the steering lock when you leave the vehicle. This will help to deter theft ⇒ ⚠.

Ignition on (normal running position) ②

The needles in the instrument cluster will sweep across the dials once after you switch on the ignition.

If the key is difficult to turn in the lock, move the steering wheel (to take the load off the steering lock mechanism) until the key turns freely. ▲

Starting the engine ③

Turn the key to this position to start the engine. While the engine is being started the headlights are switched back to side lights and other major electrical equipment is switched off. After the engine has started the ignition key returns to position ② by itself.

The ignition key has to be turned back to position ① before re-starting the engine. The **starter inhibitor** in the ignition lock prevents the starter motor from engaging when the engine is running, as this could cause damage.

WARNING

- **Wait for the vehicle to come to a standstill before removing the ignition key from the lock. Otherwise the steering lock could engage suddenly, which could cause an accident.**
- **Always take the key with you when leaving the vehicle – even if you only intend to be gone for a short time. This is especially important if children are left in the car. They might otherwise be able to start the engine or use power-operated equipment such as the electric windows - this could lead to injuries.**

Note

If the battery has been disconnected and then reconnected it will be necessary to leave the key in position ② for about 5 seconds before starting the engine. ■

Starting the engine

The engine can only be started with an original Audi key.

On vehicles with R tronic, the engine can be started in neutral (N) or in any gear (1 - 6 or R).

- Apply the handbrake firmly ⇒ .

- Push the clutch pedal all the way down (vehicles with manual gearbox).
- Press and hold the brake pedal.
- Turn the ignition key to position ③ ⇒ *page 81, fig. 72* without pressing the accelerator.
- Release the ignition key as soon as the engine starts; the starter motor must not be allowed to run on with the engine. Neutral gear (N) will be engaged on vehicles with R tronic.

When starting from cold the engine may be a little noisy for the first few seconds until oil pressure has built up in the hydraulic tappets. This is quite normal, and no cause for concern.

If the engine fails to start straight-away, switch off the starter after about 10 seconds and try again after about half a minute.

WARNING

- **Never run the engine in confined spaces. The exhaust gases are toxic.**
- **If the engine is running and a gear is engaged, you will need to hold the car with the footbrake.**

Caution

Avoid high engine speeds, full throttle and extreme load conditions until the engine has reached its normal operating temperature, otherwise this can damage the engine.

For the sake of the environment

Do not warm up the engine when the vehicle is stationary. You should drive off immediately whenever possible. This will help avoid unnecessary exhaust emissions. ■

Switching off the engine

On vehicles with R tronic, the engine can be switched off in neutral (N) or in any gear (1 - 6 or R).

- Turn the ignition key to position ① ⇒ *page 81*, fig. 72.

WARNING

- Never switch off the engine until the vehicle is stationary.
- The brake servo and the power steering system work only when the engine is running. You need more strength to steer and brake the vehicle when the engine is switched off. This would mean a greater risk of accidents and serious injury, because you cannot steer and brake in the normal manner.

Caution

- If the engine has been working hard for a long time, there is a risk of heat building up in the engine compartment after the engine has been switched off; this could cause engine damage. For this reason, you should leave the engine idling for a few minutes or drive at a moderate speed to let the engine cool down before switching it off ⇒ *page 139*.

- Because the engine can get very hot after working hard, do not park the vehicle on surfaces which could catch fire (e.g. on grass or at the forest edge).

Note

After the engine is stopped the radiator fan may run on for up to 10 minutes, even if the ignition is switched off. The fan may also start running again after some time if the coolant temperature rises due to a build-up of heat, or if the engine is hot and the engine compartment is heated up further by direct sunlight. ■

Handbrake

Handbrake

The handbrake should be applied firmly to prevent the vehicle from accidentally rolling away.

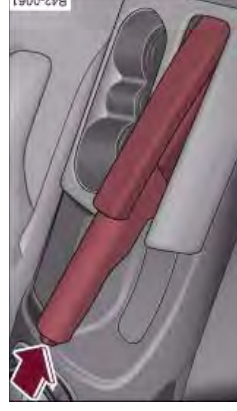



Fig. 73 Detail of the centre console: Handbrake applied

Applying the handbrake

- Pull the handbrake lever up all the way.

Releasing the handbrake

- Pull the lever up slightly and *at the same time* press in the release button ⇒ fig. 73 -arrow-.
- Keep the release button pressed and push the lever all the way down ⇒ .

The handbrake warning lamp  lights up when the handbrake is applied with the ignition on. ▲

! WARNING

Please note that the handbrake should be released all the way. If it is only partially released this will cause overheating of the rear brakes, which can impair the function of the brake system and could lead to an accident.

! Caution

Once the vehicle has come to a standstill, always apply the handbrake firmly and then engage a gear. ■

Parking the car

Please note the following points to ensure there is no risk of the car rolling away accidentally after it is parked.

- Use the foot brake to stop the vehicle.
- Apply the handbrake firmly.
- Switch the engine off.
- Engage a gear ⇒ **!.**

When parking on gradients

Turn the steering wheel so that the vehicle would roll into the kerb if it did start to move accidentally.

! WARNING

Do not leave anyone (especially children) in the vehicle when it is locked. Locked doors could delay assistance in an emergency, potentially putting lives at risk.

Never leave children unsupervised in the vehicle. They could, for example, release the handbrake or put the gearbox in neutral. The vehicle could then start moving and cause an accident. ■

Applies to vehicles: with hill hold assist

Driving away on a slope

The hill hold assist function makes it easier to drive away on a slope. The system is activated when you press and hold the brake pedal for a few seconds.

When you release the brake pedal the braking force will be maintained for a moment in order to hold the vehicle and make it easier for you to drive away.

! WARNING

- If you do not drive away immediately after releasing the brake pedal the vehicle could start to roll back. You should therefore immediately press the brake pedal or apply the handbrake.
- If the engine should stall you must immediately press the brake pedal or apply the handbrake firmly.
- If you are driving away on a slope in stop-and-go traffic press and hold the brake pedal for a few seconds before driving off. This will prevent the vehicle from rolling back unintentionally.

i Note

To find out whether your vehicle is equipped with the "hill hold assist" function please contact an Audi R8 dealership or qualified workshop. ■

Parking aid

Applies to vehicles: with 8-channel parking aid

Front and rear parking aid

The parking aid warns you if there are any obstacles behind or in front of the car.



Fig. 74 Parking aid switch in centre console

Description

The front and rear acoustic parking aid (8-channel parking aid) uses ultrasonic sensors to measure the distance between the vehicle and an obstacle. The sensors are located in the front and rear bumpers.

The measuring range of the sensors starts at **approximately**:

Side sensors	0.60 m
Centre sensors at rear	1.50 m
Centre sensors at front	1.00 m

Activating

The parking aid is activated automatically when **reverse gear** is engaged. This is confirmed by a short beep.

The parking aid can also be activated **manually** by pressing the switch P_{PA} in the centre console \Rightarrow fig. 74. This is also confirmed by a short beep. At the same time a diode in the switch will light up.

Activate the system **manually** if you are driving *forwards* and would like the system to give warning as you approach potential obstacles, for instance when parking.

Deactivating

The parking aid is switched off automatically when the vehicle reaches a speed of about 15 km/h. It also switches itself off when you stop the engine.

You can also deactivate the parking aid manually with the switch P_{PA} \Rightarrow fig. 74.

Warning beeps

The warning beeps are produced by sound boxes located at the front and rear of the vehicle. You can adjust the volume and pitch of the beeps \Rightarrow page 24.

Reversing

When the vehicle is reversing, the system starts to beep when it registers an obstacle within its detection range (see above). The warnings will beep increasingly rapidly as the vehicle approaches the obstacle.

When the vehicle is less than 0.35 m away from the obstacle the warning tone will sound continuously. The driver should then not reverse any further.

Please note that low obstacles detected by the system may no longer be registered by the sensors as the car moves closer, so the system will not give any further warning.

Driving forwards

The same proximity warnings are given when driving forwards, but obstacles have to be within a slightly closer range before they are detected (the front measuring range is shorter). The warning tone will sound continuously when the vehicle is less than 0.30 m away from the obstacle. \blacktriangle

Driving

Parking

If the parking manoeuvre involves shunting backwards and forwards, the warning sound will be switched off temporarily while you change gear. The warning beeps will start again as soon as the vehicle comes closer to an obstacle.

Possible faults

If you hear a long beep when you engage reverse gear (or when you activate the system using the switch) and the diode in the switch starts flashing, there is a fault in the system. The long warning beep is given just once to indicate the fault. If you try activating the parking aid again, the warning beep will not sound and fault is only indicated by the flashing diode. This also applies if you switch the ignition off and then on again: the long warning beep will only sound the first time you try activating the parking aid. Have the fault rectified.

If there is a fault in the system there will be no confirming beep when you activate the parking aid.

To ensure that the acoustic parking aid works properly, the sensors must be kept clean and free of ice.

WARNING

- The sensors have blind spots in which obstacles are not registered. It is particularly important to ensure that there are no small children or animals near the vehicle when reversing, as the sensors may not always be able to detect them.
- The parking aid cannot replace the full concentration of the driver. The driver is always responsible for safety during parking and other manoeuvres.

Caution

Please note that low obstacles detected by the system may no longer be registered by the sensors as the car moves closer, so the system will not give any further warning. Certain kinds of obstacles

(such as wire fences, chains, thin painted posts or trailer draw bars, etc) may not always be detected by the system, so take care not to damage the vehicle in such cases.

Note

Your vehicle has low ground clearance. To help you prevent damage to the vehicle, warning beeps will sound when you approach a steep slope (e.g. in a car park or garage). ■

Cruise control system

Applies to vehicles with cruise control system

Introduction

The cruise control system allows you to maintain a constant speed.

The cruise control system allows you to maintain any desired constant cruising speed at speeds above about 30 km/h. Of course, this is subject to power output and braking ability of the engine. This helps to reduce fatigue, especially on long journeys.

The indicator lamp  in the instrument cluster lights up when the cruise control system is operating.

The cruise control system is automatically deactivated immediately by

- pressing the brake pedal.
- pressing the clutch pedal.

WARNING

For safety reasons the cruise control system should not be used in dense traffic or poor road conditions (such as slippery surfaces, heavy rain, loose grit or gravel) – this could cause an accident.

! Caution

do not move the gear lever into neutral without depressing the clutch when the cruise control system is active. Otherwise the engine could rev up and be damaged.

i Note

The cruise control cannot maintain a constant speed when traveling down steep hills. The vehicle tends to accelerate under its own weight. Change down to a lower gear in good time or use the foot brake to slow the vehicle. ■

Applies to vehicles: with cruise control system

Setting speed

The desired cruising speed needs to be stored in the memory.



Fig. 75 Controls for the cruise control system

- Drive at the desired speed.
- Pull the lever (A) to position ⇒ fig. 75 (1) to switch on the system.
- Briefly press button (B).

When button (B) is released, the current speed is stored in the memory and the vehicle will then maintain this speed. ■

Applies to vehicles: with cruise control system

Adjusting stored speed

The desired cruising speed can be adjusted up or down as required.

To set a higher speed

- Move the lever (A) up towards ⇒ fig. 75 (+).
- Release the lever to store the current cruising speed.

To set a lower speed

- Move the lever (A) down towards ⇒ fig. 75 (-).
- Release the lever to store the current cruising speed.

You can still use the accelerator pedal to increase speed in the normal way. The previously programmed speed will be resumed when the accelerator pedal is released.

However, if the vehicle exceeds the programmed speed by more than 10 km/h for more than 5 minutes, the cruise control system will be deactivated. The speed setting will remain stored.

Pressing lever (A) briefly

You can increase the set speed in steps of 2 km/h by briefly pressing the lever (A) up towards ⇒ fig. 75 (+).

You can decrease the set speed in steps of 2 km/h by briefly pressing the lever (A) down towards ⇒ fig. 75 (-). ■

Applies to vehicles: with cruise control system

Switching off cruise control temporarily

- Press the brake pedal, or
- Press the clutch pedal, or
- Press the lever **(A)** ⇒ *page 87*, fig. 75 to position **(2)** (click stop not engaged).

The speed stored at this point remains in the memory if the system is only temporarily deactivated.

To resume the programmed cruising speed, release the clutch or brake pedal and pull the lever **(A)** to position **(1)**.

If no speed was stored when the system was temporarily deactivated, a new speed can be set as follows: drive at the desired cruising speed and briefly press button ⇒ *page 87*, fig. 75 **(B)** (SET).

WARNING

Do not resume the programmed cruising speed if this is too high for the traffic conditions - this can cause accidents. ■

Applies to vehicles: with cruise control system

Switching off cruise control

- Press the lever **A** ⇒ *page 87*, fig. 75 to position **(2)** (click stop engaged).

The stored speed will be deleted once the ignition is switched off.

Note

Always switch off the cruise control system completely after each journey. When beginning a new journey, the speed must be reset ⇒ *page 87*. ■

Applies to vehicles: with Audi magnetic ride

Audi magnetic ride

The damping effect of the shock absorbers can be adjusted according to the driver's requirements, and will adapt automatically to suit the driving conditions.



Fig. 76 Centre console: Switch for Audi magnetic ride

- Press the switch ⇒ fig. 76 to activate or deactivate the sport driving mode.

Audi magnetic ride is an electronically controlled damping system. By means of control processes going on in the background it assists the driver and adapts automatically to particular situations when driving. The adaptive **damping** varies the stiffness of the shock absorbers to suit individual requirements. For example, if the driver selects the comfort setting, the suspension damping is relatively soft and only becomes firmer when required, such as in a corner or under braking.

Normal driving mode

Select the normal setting for comfort-oriented suspension characteristics. ▲

Sport driving mode

Select the sport setting for performance-oriented suspension characteristics. The diode in the switch  will light up to indicate that the sport mode is on.

Note

The warning lamp  lights up in the instrument cluster if a malfunction occurs. Drive to the nearest qualified workshop as soon as possible and have the fault corrected. ■

Automatic gearbox

Applies to vehicles: with R tronic

Description



Fig. 77 Gear shift pattern



Fig. 78 Display: Engaged gears

R tronic is an automatic sequential-shift gearbox using shift-by-wire technology to operate the clutch and change the gears.

The gears are engaged manually (the principle is similar to a manual gearbox) but they can also be shifted automatically. The engine can be started and stopped in any gear ⇒ page 82.

The driver information system displays the selected mode, the engaged gear and the sport function ⇒ fig. 78.

M - Manual mode

In this mode, you use the selector lever ⇒ page 91 or the paddle levers on the multi-function steering wheel ⇒ page 93 to change the forward gears up and down.

A - Automatic mode

In this mode the forward gears are shifted up and down automatically according to the engine load and road speed ⇒ page 92.

R - Reverse gear

Reverse gear must only be engaged when the vehicle is stationary and the engine is idling ⇒ .

To engage reverse gear press the brake pedal then move the selector lever to the right before pulling it briefly towards the R symbol. The reversing lights come on when reverse gear is engaged with the ignition on.

N - Neutral

To engage neutral gear, the selector lever has to be moved to the right or left. If reverse gear is engaged, move the selector lever to the left. If a forward gear is engaged, move the selector lever to the right.

Sport function

Press the **(SPORT)** button to activate the sport function. Upshifts are then delayed to make use of the maximum engine power. The shift time is reduced and the accelerator pedal has a lighter response. In addition, the car does **not** automatically shift up a gear before the maximum engine speed is reached when you are in manual mode. The car will automatically shift up a gear in the normal way when you are in automatic mode. ▲

WARNING

- The accelerator pedal must on no account be pressed inadvertently when a gear is engaged with the vehicle stationary. If this were to happen, the vehicle would start to move immediately, and even a firmly applied handbrake might not restrain it (accident risk).
- To avoid accidents, apply the handbrake firmly and select neutral gear (N) before opening the engine lid and working on the vehicle with the engine running. Please observe the important safety warnings ⇒ *page 155*, "Working on components in the engine compartment".

**Note**

If you accidentally shift to N when driving, you can engage a gear in the normal way using the selector lever or paddle levers. ■

Applies to vehicles: with R tronic

Manual mode

R tronic allows the driver to change gears manually.

Driving away from a standstill

- Press and hold the brake pedal.
- Move the selector lever to the left.
- Briefly push the selector lever forwards ⊕.
- Release the brake and press the accelerator ⇒ ⚠.

Changing gear

- Briefly push the selector lever forwards ⊕ to change up a gear.

- Briefly pull the selector lever back ⊖ to change down a gear.

Stopping briefly

- Apply the foot brake to hold the vehicle when stationary (for instance at traffic lights).
- Do not press the accelerator while waiting. Neutral gear (N) will be engaged automatically and a warning tone will sound after a certain period if the vehicle is at a standstill and you do not press the brake pedal or accelerator.

Parking

- Press and hold the brake pedal ⇒ ⚠.
- Apply the handbrake firmly.
- Engage a gear.
- Switch off the ignition.

Stopping on a slope

- Always apply the footbrake to hold the vehicle and prevent it "rolling back" down the slope ⇒ ⚠. Do **not** try to stop the vehicle "rolling back" by increasing the engine speed when a gear is engaged.
- Apply the handbrake firmly.

Driving away on a slope

- Once you have engaged a gear, release the footbrake, press the accelerator and gradually release the handbrake.

When accelerating in 1st, 2nd, 3rd, 4th or 5th gear, the R tronic gearbox automatically shifts up into the next gear shortly before the ▲

Automatic gearbox

maximum engine speed is reached, unless you have activated the sport function ⇒ *page 90*.

If you select a lower gear, the R tronic gearbox will not shift down until there is no risk of overreving the engine.

You can change over to automatic mode at any time ⇒ *page 92*.

WARNING

- The driver should never get out of the vehicle when the engine is running and a gear is engaged. If you have to leave your vehicle while the engine is running, you must apply the parking brake and engage neutral gear (N).
- If the engine is running and a gear is engaged, you will need to hold the car with the footbrake.
- Do not press the accelerator while selecting a gear with the vehicle stationary and the engine running, as this could cause an accident.
- To avoid rolling back on gradients always hold the vehicle with the footbrake if you have to stop. Never attempt to hold the vehicle with the clutch when stopping on a gradient. The clutch is disengaged automatically if it is overloaded and becomes too hot - accident risk! Before the clutch is disengaged, the vehicle will jolt and the driver information system will display a warning that the clutch is overloaded.
- Before you drive down a steep gradient, reduce the speed and use the R tronic to select a lower gear.
- Never allow the brake to drag and do not use the brake pedal too often or for long periods. Constant braking will cause the brakes to overheat and will considerably reduce the effectiveness of the brakes. It will increase the braking distance and could cause the brake system to fail. ■

Applies to vehicles: with R tronic

Automatic mode

The gearbox changes the forward gears up and down automatically.

Driving away from a standstill

- Press and hold the brake pedal.
- Briefly push the selector lever towards position A.
- Release the brake and press the accelerator ⇒  in "Manual mode" on *page 91*.

In some situations (such as when driving on mountain roads) it can be advantageous to switch temporarily to the manual shift programme ⇒ *page 91*, so that the gear ratios can be selected manually to suit the driving conditions. ■

Applies to vehicles: with R tronic

Kick-down feature

When the accelerator pedal is pressed right down past the point of resistance at full throttle, the R tronic gearbox will shift down to a lower gear, depending on road speed and engine speed. The upshift to the next higher gear is delayed until the engine reaches maximum rpm. This does not apply if you have activated the sport function.



WARNING

Please note that if the road surface is slippery or wet, the kick-down feature could cause the driving wheels to spin, which could result in skidding. ■

Applies to vehicles: with R tronic

Launch control programme

The launch control programme enables maximum acceleration.

- Press the ESP switch once while the engine is running. The ESP warning lamp  will light up in the driver information system display.
- Press and hold the brake pedal with your left foot.
- Engage a gear.
- Press the **(SPORT)** button.
- Press the accelerator all the way down with your right foot until the engine reaches a constant rpm speed.
- Take your left foot off the brake ⇒ .

WARNING

- Always adapt your driving style to the traffic conditions.
- Only use the launch control programme when road and traffic conditions permit, and make sure your manner of driving and accelerating the vehicle does not inconvenience or endanger other road users.
- Please note that, when the ESP is switched off, the driven wheels may start to spin, causing the vehicle to lose grip, in particular on slippery or wet roads - danger of skidding!
- When acceleration has been completed, the ESP should be reactivated by pressing the ESP switch.



Note

Accelerating with the launch control programme places a heavy load on all parts of the vehicle. This can result in increased wear and tear. ■



Applies to vehicles: with R tronic

Steering wheel with paddle levers

The paddle levers behind the steering wheel allow you to change gear manually without taking your hands off the steering wheel.



Fig. 79 Sports steering wheel with Paddle levers

- Briefly pull the left-hand paddle lever  to change down to a lower gear.
- Briefly pull the right-hand paddle lever  to change up to a higher gear.

The manual shift programme can, of course, still be operated using the selector lever in the centre console. ■

94 Automatic gearbox

Applies to vehicles: with R tronic

Backup programme

A back-up system is in place if a fault should occur in the control system.

The R tronic gearbox switches to the back-up programme if a fault should occur in the control system. If this happens, a red bar will light up or flash in the driver information system display.

A permanently lit bar indicates that you can continue driving the vehicle.

A flashing bar indicates a serious system fault:

- The programme will only move into certain gears.
- The engine may stall.
- The engine cannot be started again after it is switched off.
- The vehicle may be damaged if you continue driving.



Caution
If the R tronic gearbox should ever switch to the back-up programme you should take the vehicle to a workshop as soon as possible. ■

HomeLink

Universal transmitter

Applies to vehicles: with HomeLink

Description

The HomeLink universal transmitter can be programmed to replace the hand-held controls of devices already in use.

The HomeLink universal transmitter allows you to conveniently activate garage doors, estate gates, security systems, home or office lighting and other electric devices by means of control buttons inside your car.

The single remote control unit that HomeLink provides will replace up to three hand-held transmitters operating existing devices on your property. This will be possible for most transmitters which control the drive units for a garage door or external gates, etc. Programming of the individual hand-held transmitters for your remote control is done at the centre of the front bumper. This is where the control unit is located.

To be able to control systems with HomeLink, you need to perform initial programming on the HomeLink transmitter first. If systems fail to respond after the initial programming, check whether these systems work with a "rolling code" (variable security code) ⇒ page 97.



WARNING

When you are programming the HomeLink universal transmitter, make sure that no persons or objects are close to the devices receiving the transmitter signals. If a gate or door is inadvertently set into motion during programming, persons might be injured or other damage caused by moving parts.



Note

- For additional information on HomeLink® and/or products compatible with HomeLink®, please call the toll-free HomeLink® hotline (0) 08000466 35465 (in Germany) or alternatively +49 (0) 6838 907 277, or visit the HomeLink® website at: www.homelink.com
- HomeLink® is a registered trademark of Johnson Controls. ■

Applies to vehicles: with HomeLink

Programming the universal transmitter

Programming of the HomeLink universal transmitter is done on the operating unit located above the interior mirror and at the front bumper.

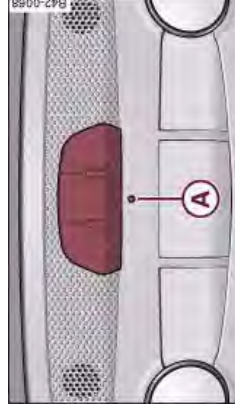

Fig. 80 Operating unit above the interior mirror

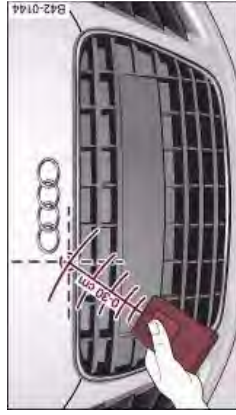

Fig. 81 Front bumper

At the operating unit

1. Switch on the ignition (do not start the engine).
2. Press and hold down the two outer buttons of the HomeLink® operating unit ⇒ *page 95*, fig. 80 until the indicator diode **A** ⇒ *page 95*, fig. 80 begins to flash after about 20 seconds. This means that all previously stored data has been deleted.
3. Press the particular HomeLink button which you would like to program.
4. Wait until the diode **A** ⇒ *page 95*, fig. 80 begins to flash. The HomeLink module now remains in training mode for 5 minutes.
5. Now step in front of your vehicle with the **original hand-held transmitter** for the garage door opener or any other device you wish to assign to the HomeLink control button ⇒ fig. 81.

At the front bumper

6. Hold the **original hand-held transmitter for the device you wish to program** close to the front bumper, directly above the radiator grille ⇒ fig. 81.

7. Press the activator button on the **original hand-held transmitter**.

8. As you do so, watch the turn signals on your vehicle. HomeLink confirms successful programming by flashing all four turn signals **three times**.

9. If the turn signals fail to flash three times, repeat the procedure with the transmitter held at a different distance from the bumper.

The proper distance between the hand-held transmitter and the HomeLink module inside the front bumper depends on the system you want to train. It may require several attempts.

The turn signals will flash **once** if the time limit for the programming mode has been exceeded. In this case the programming procedure needs to be performed again. Repeat the sequence on the operating unit starting with step 3.

The programming instructions above also apply to the other control buttons. Start with step 3 on the operating unit if you wish to proceed and program the other two buttons.

If the garage door or other devices still fail to be activated with the HomeLink control buttons after programming is completed, it is possible that these systems might be working with a rolling code instead of the normal fixed security code. If this is the case, a **rolling code programming** is required in addition to the steps described above ⇒ *page 97*. ■

Applies to vehicles: with HomeLink

Rolling code programming

Some devices require rolling code programming of the HomeLink universal transmitter.

Identifying a rolling code

- Press the already programmed HomeLink button again and hold it down.
- Watch HomeLink diode (A) ⇒ *page 95*, *fig. 80*. If the diode starts flashing rapidly and turns into a constant light after about 2 seconds, this indicates that the device you wish to operate (e.g. a garage door opener) is equipped with a rolling code.
- Program the rolling code as follows:

Activating the garage door opener drive unit

- Locate the programming button on the garage door drive. The exact location and colour of the button may vary depending on the type of garage door opener.
- Press the programming button on the door drive unit (this will normally cause a "programming mode indicator lamp" on the unit to light up). You now have about **30 seconds** to start and complete programming of the HomeLink control button on the operating unit.

Programming of the operating unit above the interior mirror

- Press and release the already programmed HomeLink button.
- Press the HomeLink button again to complete rolling code programming.

After programming at the operating unit, the garage door opener should recognise the HomeLink signal and respond when the HomeLink button is pressed. Now the other control buttons can be programmed as required.



Note

- Having a second person assist you makes programming of the rolling code easier and faster. For some makes of garage door openers the HomeLink button may have to be pressed a third time to complete the training sequence.
- If you encounter problems programming the rolling code you may find helpful information in the operating instructions of the garage door opener or other device you wish to operate. ■

Applies to vehicles: with HomeLink

Operating HomeLink

The programmed devices are activated by means of the HomeLink control buttons above the interior mirror.

- Switch on the ignition (do not start the engine).
- Press the programmed HomeLink button ⇒ *page 95*, *fig. 80*. The device assigned to that button (e.g. garage door) will be activated.

The HomeLink indicator diode ⇒ *page 95*, *fig. 80* will light up when you press the button. ■

Applies to vehicles: with HomeLink

Erasing the HomeLink® button programming

You can erase the complete HomeLink programming by pressing the two outer buttons.

- Switch on the ignition (do not start the engine). ▶

- Press and hold down the two outer buttons until the indicator diode starts to flash ⇒ *page 95*, fig. 80.
- Then release the buttons.

After the programming of the HomeLink® universal transmitter has been erased, the system will return to the training mode and is ready to be re-programmed at any time.

Note

- Programmed buttons cannot be erased individually.
- For security reasons it is advisable to erase the programming of the HomeLink buttons prior to selling your vehicle. ■

Applies to vehicles: with HomeLink

Reprogramming a HomeLink® button

A HomeLink button can be re-programmed individually without affecting the other button allocations.

At the operating unit

- Press and hold down the selected HomeLink® button until the indicator diode ⇒ *page 95*, fig. 80 starts flashing slowly.

At the front bumper

- Hold the **original hand-held transmitter** for the garage door opener or other device close to the front bumper directly below the right headlight ⇒ *page 96*, fig. 81. The exact distance depends on the system that you want to program.
- Press the button on the **original hand-held transmitter** for the garage door opener or other device.

- As you do so, watch the turn signals on your vehicle. HomeLink confirms successful programming by flashing all four turn signals **three times**.

- If the turn signals fail to flash three times, repeat the procedure with the transmitter held at a different distance from the bumper.

When the turn signals have flashed three times, this means the device previously stored in HomeLink has been erased and the new system programmed in its place. To activate the new system, press the HomeLink button that has just been re-programmed.

Note

It may require several attempts before programming is successful. When programming a new device, keep the button pressed for at least 15 seconds before trying again with the transmitter in a different position. Keep watching the turn signals during that time. ■

Applies to vehicles: with HomeLink

Conformity certification

The HomeLink universal transmitter is registered in the following countries under the following certification numbers:

Country	Certification number
Andorra	16SEP2003
Belgium	RTT/D/X2064
Denmark	98.3142-266
Germany	D800038K
Finland	F198080106
France	97619 RD

Country	Certification number
Gibraltar	RTTE 20754/0087847
Greece	JCI 05JUL2000 RTTE
Great Britain	RTTE 20754/0087847
Republic of Ireland	TRA 24/5/109/5
Iceland	IS-3418-00
Italy	DGPGF/4/341032/TB 0002573
Croatia	SRD-156/03
Luxembourg	L2433/10510-03J
Malta	WT/122/98
Monaco	PC/cp-CI.T55-03/04672
Netherlands	NL99030970
Norway	NO20000026
Austria	GZ104569-ZB/98
Poland	URT-GP-CLBT-431-66/2002/C
Portugal	JCI 03JUL2000 RTTE
Sweden	Ue990195
Switzerland	BAKOM 98.0746.K.P
Slovak Republic	R 267 2001 N
Spain	0416 00
Czech Republic	CTU 2000 3 R 1194
Turkey	0425/TGM-TR/JOCO-EURO
Hungary	BB-5793-1/2000
Cyprus	MCW129/95 12/2000

Controls

Safety

Driving tips

General maintenance

Self-help

Technical data





Safe driving

General notes

Safety is the first priority

Your safety is our first priority.

This chapter contains important information, tips, suggestions and warnings that you should read and observe for your own safety and the safety of your passengers.

WARNING

- The information in this chapter is important for the driver of the vehicle and all passengers. The other chapters in this manual (and, where applicable, in the other literature supplied with the vehicle) contain further important notes which you should read and observe for your own safety and that of your passengers.
- Ensure that the complete vehicle wallet is always in the vehicle. This is especially important when you lend or sell the vehicle to others. ■

Safety features

The safety features listed here are part of the vehicle's occupant restraint system. They work together to help reduce the risk of injury in a wide variety of accident situations.

Your safety and the safety of your passengers should not be left to chance. In the event of an accident, the safety features incorporated in your vehicle are capable of reducing the risk of injury. These are just a few of the safety features in your Audi:

- Three-point seat belts for all seats,

- Belt force limiters for the front seats,
- Belt pre-tensioners for the front seats,
- Front airbags,
- Head/thorax airbags in the backrests,
- "ISOFIX" mountings* for "ISOFIX" child safety seats on the front passenger's seat,
- Height-adjustable head restraints in the backrests,
- Adjustable steering column.

These individual safety features are harmonised to provide you and your passengers with the best possible protection in accident situations. However, they can only be effective if you and your passengers sit in the correct position and adjust and use the safety equipment properly.

For these reasons, this chapter explains why these safety features are so important, how they can protect you, what you need to remember when using them, and how you and your passengers can gain the most benefit from them. There are also a number of important safety warnings which you and your passengers should always observe in order to minimise the risk of injury.

Safety is everyone's responsibility! ■

Before every trip

The driver is responsible for the safety of the passengers and the safe operation of the vehicle at all times.

For your own safety and the safety of your passengers, always note the following points before every trip:

- Make sure that all lights and turn signals are working properly. ▲

- Check the tyre pressures.
 - Make sure that all windows are clean and give good visibility to the outside.
 - Secure all luggage and other items carefully.
 - Make sure that no objects can interfere with the pedals.
 - Adjust the front seat, head restraint and mirrors correctly.
 - Make sure that the head restraints for all passengers are adjusted to the correct position.
 - Make sure that children are protected with suitable safety seats and properly worn seat belts ⇒ page 122.
 - Sit in the correct position in your seat and make sure that your passengers do the same. ⇒ page 67.
 - Fasten your seat belt correctly. Make sure that your passengers do the same ⇒ page 109. ■
- ! WARNING**

 - Distractions while driving or any kind of impairment to your driving ability increase the risk of accident and injury.
 - Do not store loose objects on the dashboard. These objects could fly around the interior when the vehicle is moving (under acceleration or whilst cornering) and distract the driver – this could lead to an accident. ■
- Obey all traffic regulations and speed limits.
 - Always adjust your speed to suit the road, traffic and weather conditions.
 - Take frequent breaks on long trips. Do not drive for more than two hours without a stop.
 - If possible, avoid driving when you are tired or stressed.

What affects driving safety?

Safety on the road is directly related to how you drive, and can also be affected by the passengers in the vehicle.

The driver is responsible for the safety of the vehicle and all its occupants. If your ability to drive is impaired in any way, you endanger yourself and other road users ⇒ . Therefore:

- Do not let yourself be distracted by passengers or by using a mobile phone, etc.
- Never drive when your driving ability is impaired (by medication, alcohol, drugs, etc.).

Correct sitting positions

Correct sitting position for driver

The correct driving position is important for safe and fatigue-free driving.



Fig. 82 Minimum distance between driver and steering wheel

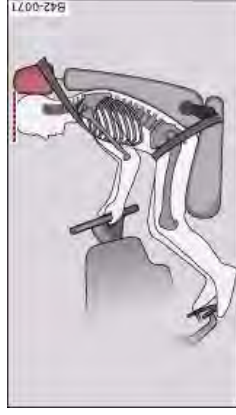



Fig. 83 Correct head restraint position for the driver

For your own safety, and to reduce the risk of injury in the event of an accident, we recommend the following driving position.

- Adjust the steering wheel so there is a distance of at least 25 cm between the steering wheel and your breastbone ⇒ fig. 82.

- Move the driver's seat forwards or backwards so that you can press the accelerator, brake and clutch pedals all the way to the floor with your knees slightly bent ⇒ .
- Make sure that you can comfortably reach the top of the steering wheel.
- Adjust the head restraint so that the top of the head restraint is level with the top of your head ⇒ fig. 83.
- Adjust the backrest to an upright position so that your back remains in contact with the upholstery.
- Fasten your seat belt correctly ⇒ page 109.
- Keep both feet in the footwell so that you are in full control of the vehicle at all times.

For detailed information on how to adjust the driver's seat, see ⇒ page 67, "Seats and storage".

WARNING

An incorrect driver sitting position can result in serious personal injury.

- Adjust the driver's seat so there is a distance of at least 25 cm between your breastbone and the centre of the steering wheel ⇒ fig. 82. The airbag system will not be able to protect you properly if you sit closer than 25 cm.
- If physical limitations prevent you from maintaining the minimum distance of 25 cm, please consult a qualified workshop. The workshop will be able to tell you whether your vehicle can be suitably modified.
- While driving, always hold the steering wheel with both hands on the outside of the rim at about the 9 o'clock and 3 o'clock position. This reduces the risk of injury if the driver's airbag inflates.

- Fasten your seat belt correctly ⇒ *page 112*.

In **exceptional cases** you can disable the front passenger's airbag ⇒ *page 120*.

For detailed information on how to adjust the front passenger's seat, see ⇒ *page 67*, "Seats and storage".

WARNING (continued)

- Never hold the steering wheel at the 12 o'clock position, or with your hands inside the rim or on the steering wheel hub. This could result in serious injuries to the arms, hands and head if the driver's airbag inflates.
- To reduce any risk of injury to the driver during a sudden brake application or in an accident, never drive with the backrest tilted too far back. The airbag system and seat belts can only provide proper protection when the backrest is in an upright position and the driver is wearing the seat belt in the correct position. The further the backrest is tilted back, the greater the risk of injury due to incorrect positioning of the belt webbing or an incorrect sitting position.
- Adjust the head restraint properly so that it can give maximum protection. ■

Correct sitting position for front passenger

The front seat passenger must sit at least 25 cm away from the dash panel so that the airbag has enough room to inflate and give maximum protection in an accident.

For your own safety and to reduce the risk of injury in the event of an accident, we recommend adjusting the front passenger's seat as follows:

- Move the front passenger's seat as far back as possible ⇒ .
- Adjust the backrest to an upright position so that your back remains in contact with the upholstery.
- Adjust the head restraint so that the top of the head restraint is level with the top of your head ⇒ *page 106*.
- Keep both feet in the footwell in front of the seat.

WARNING

A passenger sitting out of position in the front seat can suffer serious injuries.

- Adjust the front passenger's seat so there is a distance of at least 25 cm between your breastbone and the dash panel. The airbag system will not be able to protect you properly if you sit closer than 25 cm.
- If physical limitations prevent you from maintaining the minimum distance of 25 cm, please consult a qualified workshop. The workshop will be able to tell you whether your vehicle can be suitably modified.
- Always keep your feet on the floor when the vehicle is moving; never rest them on the instrument panel, out of the window or on the seat. If you sit in an incorrect position, you increase your risk of injury in the event of sudden braking or an accident. If the airbag is triggered, you could sustain potentially fatal injuries by sitting out of position.
- To reduce the risk of injury to the front passenger in the case of sudden braking or an accident, the passenger should never travel in a moving vehicle with the backrest reclined. The airbag system and seat belt can only provide proper protection when the backrest is in an upright position and the passenger is wearing the seat belt in the correct position. The further the backrest is tilted back, the greater the risk of injury due to incorrect positioning of the belt webbing or an incorrect sitting position.
- Always adjust the head restraints properly for maximum protection. ■

Correct adjustment of head restraints

Properly adjusted head restraints are an important part of the vehicle's occupant protection system. They can help to reduce the risk of injuries in most accident situations.

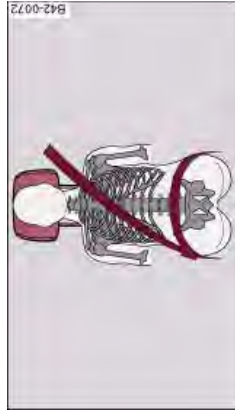

Fig. 84 Correctly adjusted head restraint (seen from the front)

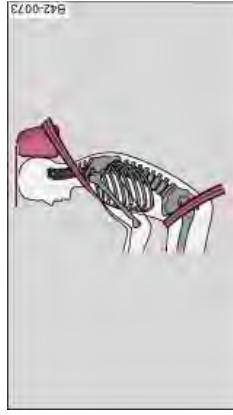

Fig. 85 Correctly adjusted head restraint (seen from the side)

The head restraints must be adjusted properly to provide maximum protection.

- Adjust the head restraint so that the top of the head restraint is level with the top of your head ⇒ fig. 84 and ⇒ fig. 85.

For more information on how to adjust the head restraints, see ⇒ page 71.

WARNING

Travelling with the head restraints removed or incorrectly adjusted increases the risk of severe injuries.

- Incorrectly adjusted head restraints could lead to death in the event of a collision or accident.
- Incorrectly adjusted head restraints can also increase the risk of injury during sudden or unexpected braking or other manoeuvres.
- The head restraints must always be adjusted according to the occupant's size. ■

Examples of incorrect sitting positions

Occupants can suffer severe or fatal injuries if they sit in an incorrect position while the vehicle is moving.

Seat belts can only provide maximum protection if the belt webbing is positioned correctly. Sitting out of position greatly reduces the effectiveness of the seat belts and increases the risk of injury since the belt webbing is not worn in the position for which it is designed. The driver is responsible for the safety of all vehicle occupants, especially for children.

- Never allow anyone to sit out of position while the vehicle is moving ⇒

The following list shows just some examples of incorrect sitting positions which can be dangerous to all occupants. The list is not complete, but will help to make you aware of possible dangers which can be avoided.

Therefore, whenever the vehicle is moving:

- never stand up in the vehicle,

- never stand on the seats,
- never kneel on the seats,
- never travel with the backrest reclined too far,
- never lean against the dash panel,
- never sit on the front edge of a seat,
- never sit sideways,
- never lean out of the window,
- never put your feet out of the window,
- never put your feet on the dash panel,
- never put your feet on the seat cushion,
- never ride in the footwell,
- never travel on a seat without wearing the seat belt.

**WARNING**

Sitting out of position increases the risk of severe injuries.

- **Sitting out of position exposes the occupants to potentially fatal injuries: if the airbags inflate they can strike any occupant who is not in one of the designed seat positions.**
- **Before starting a trip, sit in the correct position and stay in this position as long as the vehicle is moving. Before every trip, make sure all passengers are sitting in the correct positions and remain correctly seated at all times ⇒ page 67, "Seats and storage". ■**

Pedal area

Pedals

The pedals must always be free to move and must never be obstructed by floor mats or any objects in the footwell.

- Make sure that the accelerator, brake and clutch pedals are not obstructed and can be pressed all the way down to the floor.
- Make sure that all pedals are able to return freely to their original positions.

Only use floor mats which leave the pedal area free and can be securely fastened in the footwell.

If one of the brake circuits should fail, increased brake pedal travel will be required to bring the vehicle safely to a stop.

**WARNING**

Any obstructions that restrict pedal travel can cause loss of vehicle control and critical situations in traffic.

- **Never place objects in the driver's footwell. Such objects could move under the pedals and interfere with their proper function. In the event of sudden braking or a change of direction, you would not be able to use the pedals. This could result in a loss of control and possibly cause an accident. ■**

Floor mats on the driver's side

Use only floor mats which can be securely fastened in the footwell and do not obstruct the pedals.

- Make sure that floor mats are securely fastened and cannot interfere with the pedals ⇒ .

Use only floor mats that leave the pedal area unobstructed and are firmly secured to prevent them from slipping. You can obtain suitable floor mats from your dealer or a specialist retailer.

WARNING

Any obstructions that restrict pedal travel can cause loss of vehicle control and increase the risk of serious personal injury.

- Always make sure that floor mats are properly secured.
- Never lay or install additional floor mats or other floor coverings over the existing floor mats; this would restrict the pedal area and possibly obstruct the pedals, which could cause an accident. ■

Stowing luggage safely

Notes

All luggage and objects must be securely stowed.

Loose items can cause a safety hazard or impair the handling of the vehicle by changing the weight distribution.

During a collision or an accident, even small and light objects can possess so much energy that they can cause very severe injuries. The amount of this "kinetic energy" depends on the speed of the vehicle and the weight of the object. The most significant factor, however, is the speed of the vehicle.

An example: An object weighing 4.5 kg is lying unsecured in the vehicle. During a frontal collision at a speed of 50 km/h, this object generates a force corresponding to 20 times its weight. That means that the effective weight of the object increases to about 90 kg. You can imagine the severity of the injuries which might be sustained if this "projectile" strikes an occupant as it flies through the passenger compartment.

WARNING

- Always stow objects in the luggage compartment.
- Transporting heavy objects may affect the vehicle's handling by shifting the centre of gravity – this could cause an accident. Take extra care when driving and adjust your speed accordingly.
- Never exceed the maximum axle loads or the maximum gross weight for the vehicle ⇒ *page 198*, "Performance, weights and dimensions". Exceeding the permitted axle loads or gross weight limit can affect the vehicle's handling characteristics, and increase the risk of accidents, personal injuries or damage to the vehicle.
- Never leave your vehicle unattended when the luggage lid is open. Children could climb into the luggage compartment and close the luggage lid from the inside. In this case the child would be unable to get out of the vehicle without help. This could have fatal consequences.
- Never allow children to play in or around the vehicle. Always close and lock the luggage lid and all the doors when you leave the vehicle.
- Never let passengers ride in the luggage compartment. All occupants must be properly restrained by the seat belts at all times ⇒ *page 109*. ■

Seat belts

Why is it so important to use seat belts?

Seat belts provide effective protection

The common belief that passengers can brace their weight with their hands in a minor collision is false.



Fig. 86 Driver with properly positioned seat belt – good protection if the brakes are applied suddenly

It is an established fact that seat belts provide good protection in accidents. Therefore wearing a seat belt is required by law in most countries.

Properly worn seat belts hold the occupants in the best position for maximum protection → fig. 86. The seat belts are capable of absorbing much of the kinetic energy arising in a collision. Also they help to prevent uncontrolled movements which could lead to severe injuries → page 110, "Important safety instructions for using seat belts".

If they wear the seat belts correctly, the passengers benefit greatly from the ability of the belts to reduce the kinetic energy gradually. The front crumple zones and other passive safety features (such as the airbag system) are also designed to absorb the kinetic energy generated in a collision. Taken together, all these features reduce

the forces acting on the occupants and consequently the risk of injury.

Although these examples are based on a frontal collision, the physical principles involved are the same in other types of accidents and for vehicles with an airbag system. This is why it is so important to put on the seat belts before every trip – even when "just driving around the corner". Ensure that your passengers wear their seat belts as well → .

Properly worn seat belts have been shown to be an effective means of reducing the potential for injury and improving the chances of survival in a serious accident → page 110, "Forces acting in a collision".

For information on how children can travel safely in the car → page 122, "Points to remember if children are travelling in the car".

WARNING

- **Seat belts must be put on before every trip – even when driving in town. This also applies to the rear passengers (injury risk).**
- **During pregnancy, women should always ensure they wear a seat belt. The best way to protect the unborn child is to protect the mother → page 113, "Wearing and adjusting the seat belts during pregnancy".** ■

Important safety instructions for using seat belts

There are a number of safety points concerning the seat belts which you should remember. This will help to reduce the risk of injury in an accident.

! WARNING

- The seat belts can only provide maximum protection if the seats are adjusted properly ⇒ *page 67, "Seats and storage"*.
- To ensure proper protection, it is important to wear the seat belts in the correct position ⇒ *page 112, "How to wear seat belts properly"*. Ensure that the seat belts are worn exactly as recommended in this chapter. Belts which are not worn properly can increase the risk of injury in accidents considerably.
- Do not allow the seat belt to become twisted or jammed, or to rub on any sharp edges.
- Never allow two passengers (even children) to share the same seat belt. It is especially dangerous to place a seat belt over a child sitting on your lap.
- Do not wear the belt over hard or fragile objects (such as glasses or pens, etc.) because this can cause injuries.
- Loose, bulky clothing (such as an overcoat over a jacket) impairs the proper fit and function of the belts.
- The belts must be kept clean, otherwise the retractors may not work properly ⇒ *page 150, "Seat belts"*.
- The slot in the seat belt buckle must not be blocked with paper or other objects, as this can prevent the latch plate from engaging properly.
- The latch plate of the belt must always be engaged in the correct buckle for that seat, otherwise the belt will not be fully effective.
- Check the condition of the seat belts at regular intervals. If you notice that the belt webbing, fittings, retractor mechanism or

! WARNING (continued)

buckle of any of the belts is damaged, the belt must be replaced by a qualified workshop.

- The seat belts must not be removed or modified in any way. Do not attempt to repair a damaged belt yourself.
- Seat belts which have been worn in an accident and stretched must be replaced by a qualified workshop. The belt anchorages should also be checked. ■

Forces acting in a collision

The physical principles involved in a frontal impact

Very large forces are generated during a collision; these forces have to be absorbed.



Fig. 87 Passengers of a vehicle which is headed for a brick wall. They are not using seat belts.

What happens to passengers not wearing seat belts?

Passengers not wearing seat belts risk fatal injuries in the event of an accident.



Fig. 88 The vehicle crashes against the wall

The physical principles involved in a frontal collision are relatively simple:

Both the moving vehicle and the passengers possess energy, which is known as "kinetic energy" ⇒ page 110, fig. 87. The amount of "kinetic energy" depends on the speed of the vehicle and the weight of the vehicle and passengers. The higher the speed and the greater the weight, the more energy there is to be absorbed in an accident. The most significant factor, however, is the speed of the vehicle. If the speed doubles from 25 km/h to 50 km/h, for example, the kinetic energy increases by a factor of four. Because these passengers are not restrained by seat belts, the entire amount of kinetic energy has to be absorbed at the point of impact ⇒ fig. 88. This would result in serious or potentially fatal injury.

Even at urban speeds of 30 km/h to 50 km/h, the forces acting on the occupants in a collision can reach the equivalent of 1 ton (1000 kg) or more. At greater speed these forces are even higher. A rule of thumb: if the speed doubles, the forces increase by a factor of four. Passengers who do not wear seat belts are not "attached" to the vehicle. In a frontal collision they will continue to move forward at the speed their car was travelling just before the impact. ■



Fig. 89 A driver not wearing a seat belt can be thrown forwards

In a frontal collision, unbelted passengers will be thrown forwards and make violent contact with the steering wheel, dashboard, windscreen, etc ⇒ fig. 89. Passengers not wearing their belts risk being thrown out of the car, resulting in potentially fatal injuries.

The common belief that occupants can brace their weight with their hands in a minor collision is false. Even at low speeds the forces acting on the body in a collision are so great that it is not possible to hold yourself in the seat. ■

How to wear seat belts properly

Putting on the three-point seat belts

Always fasten your seat belts before driving off.



Fig. 90 Positioning of head restraints and seat belts



Fig. 91 Driver's seat: Belt buckle and latch plate

- Adjust the front seat and head restraint correctly before putting on the seat belt ⇒ [page 67](#), "Seats and storage".
- To fasten the belt, take hold of the latch plate and pull it slowly across your chest and lap ⇒ .
- Insert the latch plate into the buckle for the appropriate seat and push it down until it is securely locked with an audible click ⇒ [fig. 91](#).

- Pull the belt to check that it is now securely fastened.

The three-point inertia reel belts are tensioned automatically. The retractor system gives complete freedom of movement, as long as the pull on the belt is slow. Hard braking locks the belt. The belt will also lock when you accelerate, drive up or down a steep hill or in a sharp curve.

WARNING

- Always make certain that the belt is positioned properly ⇒ [fig. 90](#) – risk of injury ⇒ [page 112](#), "Adjusting the seat belts".
- The latch plate of the belt must always be engaged in the correct buckle for that seat. Otherwise the belt will not be fully effective and the danger of injury increases. ■

Adjusting the seat belts

Always position seat belts properly for maximum safety.

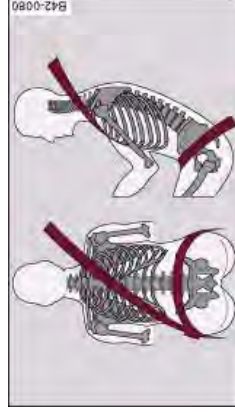

Fig. 92 Adjusting shoulder and lap belt

Your vehicle is equipped to help you position the seat belt properly to suit your height:

- Seat height adjustment (front seats)

**WARNING**

- The diagonal part of the belt should never be positioned across the neck, but roughly over the centre of the shoulder; it should fit closely against the upper part of the body. The lap part of the belt must be worn tightly across the hips, and not over the abdomen => page 112, fig. 92. Pull the belt tight if necessary to take up any slack.
- Always make sure that belt is positioned properly. Incorrectly worn seat belts can give rise to injuries even in a minor collision.
- Seat belts worn too loose can result in injuries because they allow excessive forward movement in a crash; the occupant will be brought to a sudden stop by the belt webbing. ■

Wearing and adjusting the seat belts during pregnancy

To afford the best protection for the unborn child it is important for the mother to wear the seat belt properly at all times.



Fig. 93 Positioning seat belts during pregnancy

Women should always ensure they adjust the seat belt correctly during pregnancy.

- Adjust the front seat and head restraint correctly before putting on the seat belt => page 67, "Seats and storage".
- To fasten the belt, take hold of the latch plate and pull it slowly down across your chest. Wear the lap portion of the seat belt as low as possible over the hips so that there is no pressure on the stomach => fig. 93, => ▲.
- Insert the latch plate into the buckle for the appropriate seat and push it down until it is securely locked with an audible click => page 112, fig. 91.
- Pull the belt to check that it is now securely fastened.

**WARNING**

During pregnancy, women should especially make sure to wear the lap portion of the seat belt as low as possible across the hips so that there is no pressure on the stomach. ■

Taking off the seat belts

The red button releases the belt from the buckle.



Fig. 94 The latch plate of the belt springs out of the buckle

- Press the red button in the seat belt buckle => fig. 94. The latch plate will spring out of the buckle. ▲

- Guide the belt back by hand so that it is taken up by the retractor. ■

Belt tensioners

How the belt tensioners work

The seat belts for the driver and front passenger are equipped with belt tensioners.

The seat belts on the front seats are tensioned automatically in frontal and side impacts above a certain degree of severity. This helps to reduce the forward motion of the occupants.

In a less severe accident, or in the event of a roll-over, the belt tensioners are not activated.



WARNING

- Any work on the tensioner system or removal and installation of system components for other repairs must be performed by a qualified workshop.
- The belt tensioners can only be activated once. If they have been activated at any time, the system must be replaced.



Note

- Some smoke may be released when the belt tensioners are activated. This does not mean there is a fire in the vehicle.
- The relevant safety requirements must be observed when the vehicle or components of the system are scrapped. Your authorised Audi R8 dealer is familiar with these regulations and will be pleased to pass on the information to you. ■

Airbag system

Description of airbag system

General notes on airbag system

The airbag is an integral part of the car's passive safety system.

In conjunction with the three-point seat belts, the airbag system gives the front occupants additional protection for the head and chest in the event of a severe frontal collision.

In a side collision the side airbags reduce the risk of injury to the areas of the body facing the impact ⇒ .

In addition to their normal function of protecting the occupants in a collision, the seat belts also hold them in a position where the airbags can inflate properly and provide maximum protection.

The airbag system will only work with the ignition on. The airbag system is monitored electronically; the airbag warning lamp indicates whether the system is functioning properly.

The main parts of the airbag system are:

- the electronic monitoring system (control unit and sensors),
- the two front airbags,
- The two side airbags,
- The airbag warning lamp in the instrument cluster.

There is a fault in the airbag system if the warning lamp

- does not come on when the ignition is switched on,
- does not go out about 3 seconds after the ignition is switched on,
- goes out and then comes on again after the ignition is switched on,

- comes on or flickers while the car is moving.

WARNING

• The airbags are not a substitute for the seat belts; they are an integral part of the car's overall passive safety system. The airbags can only offer effective protection if the occupants are wearing their seat belts. For this reason it is very important to wear the seat belts at all times ⇒ page 109, "Why is it so important to use seat belts?".

• The seat belts and airbags can only provide maximum protection if the occupants are seated correctly ⇒ page 67, "Seats and storage".

• If you do not wear a seat belt, if you lean forward, or are not seated correctly while the vehicle is in motion, you are at greater risk of injury should the airbag system be triggered in an accident.

• Components of the airbag system are located in various parts of the vehicle. If repairs to other vehicle components make it necessary to perform work on the airbag system or to remove or install parts of the airbag system, this may cause damage to the airbag system. As a result, the airbags may not inflate correctly or may not be triggered at all in an accident situation.

• If a fault should occur in the airbag system, have the system checked immediately by a qualified workshop. Otherwise the system may fail to trigger in an accident.

• Do not attempt to modify components of the airbag system in any way.

• Never make any alterations to the front bumper or the body.

• The airbag system can only be activated once; if the airbag has been triggered, the system must be replaced. Should the airbag system or airbag modules have to be replaced, the qualified workshop carrying out the replacement will document all details in the appropriate section of the Service Schedule.

WARNING (continued)

- If you sell the vehicle, please remember to pass on the complete Service Wallet to the new owner. If the front passenger's airbag has been deactivated, it is important that the new owner is also given the relevant documents.
- The relevant safety requirements must be observed when the vehicle or components of the airbag or belt tensioner systems are scrapped.
- In an accident in which one or more airbags are triggered the alternator and the starter are - for safety reasons - both disconnected from the battery via a pyrotechnic circuit breaker.
 - Any repairs to the pyrotechnic circuit breaker must always be performed by a qualified workshop (accident risk).
 - The relevant safety requirements must be observed when the vehicle or the circuit breaker are scrapped. ■

different types of accident will vary considerably. Important factors include, for example, the nature (hard or soft) of the object which the car hits, the angle of impact, vehicle speed and so on.

Whether the airbags are triggered depends primarily on the vehicle deceleration rate resulting from the collision. By processing the signals from the sensors located in the vehicle, the electronic control unit is immediately able to evaluate the severity of the collision and activate the restraint systems accordingly. If the deceleration rate is below the predefined reference value in the control unit the airbags will not be triggered, even though the accident may cause extensive damage to the car.

**Note**

The airbag releases a fine dust when it inflates. This is quite normal and does not mean there is a fire in the vehicle. ■

Front airbags

Description of front airbags

The airbag system is not a substitute for the seat belts.

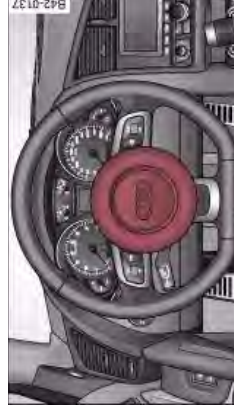

Fig. 95 Driver's airbag in steering wheel ▲

When are the airbags triggered?

The airbag system is triggered in collisions with a severe impact.

The airbag system is designed so that the airbags for the driver and front passenger are triggered in a severe **frontal collision**.

In severe **side collisions** the side airbags are triggered on the impact side of the vehicle.

In certain types of accident the front airbags and the side airbags may be triggered together.

The airbag system is **not triggered** in minor frontal or side collisions, or in rear collisions or if the car overtakes. In these situations the occupants are protected by wearing the seat belts.

Factors determining the triggering response

It is not possible to define the exact triggering response of the airbag system in all possible situations, since the circumstances in



Fig. 96 Front passenger's airbag in dashboard

The front airbag for the driver is located in the padded hub of the steering wheel ⇒ page 116, fig. 95. The front airbag for the front passenger is in the dashboard above the glove box ⇒ fig. 96. The locations of the airbags are marked with the word "AIRBAG".

In conjunction with the three-point seat belts, the front airbags give additional head and chest protection for the driver and front passenger in the event of a severe frontal collision ⇒ ⚠ in "important safety notes on the front airbag system" on page 117. ■

How the front airbags work

When fully inflated, the airbags reduce the risk of head or chest injury.



Fig. 97 Front airbags in inflated condition

The airbag system is designed so that the airbags for the driver and front passenger are triggered in a severe frontal collision.

In certain types of accident the front airbags and the side airbags may be triggered together.

When the system is triggered, the airbags fill with a propellant gas and open out in front of the driver and front passenger ⇒ fig. 97. In order to provide the desired extra protection in an accident, the airbags have to inflate extremely rapidly (within fractions of a second). The fully deployed airbags cushion the forwards movement of the front occupants and help to reduce the risk of injury to the head and the upper part of the body.

Special openings in the airbag allow the gas to escape at a controlled rate to restrain the forward movement of the occupant's head and torso. Once the impact has been absorbed, the airbag deflates sufficiently for the front occupants to see forward. ■

Important safety notes on the front airbag system

There are a number of safety points concerning the airbag system which you should remember. This will help to reduce the risk of injury in an accident.



Fig. 98 Minimum distance from steering wheel

⚠ WARNING

- It is important for the driver and front passenger to maintain a distance of at least 25 cm from the steering wheel or dashboard ⇒ *page 117*, *fig. 98*. The airbag system will not be able to give the required protection if you sit too close to the steering wheel or dashboard. There is also a risk of injury if the airbags are inflated. The front seats and head restraints must always be positioned correctly for the height of the occupant.
- If you do not wear a seat belt, if you lean forward or to the side, or are not seated correctly while the vehicle is in motion, you are at greater risk of injury. Should the airbag system be triggered in an accident there is an even greater risk of injury.
- Never let a child travel on the front seat without an appropriate restraint system. If the airbag is triggered in an accident, the child could sustain serious or fatal injuries ⇒ *page 122*, "Child safety".
- Never install a rearward-facing child safety seat on the front passenger's seat unless the front passenger's airbag has been deactivated. However, if you have no alternative but to use a rearward-facing child seat on the front passenger's seat, the front passenger's airbag must be deactivated beforehand by means of the key-operated switch ⇒ *page 120*, "Deactivating the airbags". Failure to observe this precaution could result in serious or potentially fatal injury.
- Occupants sitting in the front of the car must never carry any objects or pets in the space between them and the airbags, or allow children or other passengers to travel in this position.
- Do not cover or stick anything on the steering wheel hub or the soft plastic surface of the airbag unit on the passenger's side of the dashboard, and do not obstruct or modify them in any way. These parts should only be cleaned with a dry cloth (or with a cloth moistened with plain water). It is also important not to attach any objects such as cup holders or telephone mountings to the surfaces covering the airbag units.

⚠ WARNING (continued)

- Any work on the airbag system or removal and installation of the airbag components for other repairs (such as repairs to the steering wheel) should be performed by a qualified workshop.

i Note

If necessary, you can deactivate the front passenger's airbag by means of the key-operated switch ⇒ *page 120*, "Deactivating the airbags". ■

Side airbags

Description of side airbags

The airbag system is not a substitute for the seat belts.



Fig. 99 Location of side airbag in driver's seat

The side airbags are located in the backrest padding of the front seats ⇒ *fig. 99*. The locations of the airbags are marked with the word "AIRBAG".

In conjunction with the three-point seat belts, the side airbags give the occupants additional protection for the whole upper part of the body (i.e. the chest, stomach and pelvis) in the event of a severe side

collision ⇒  in "Important safety notes on the side airbag system" on page 119.

In a side collision the side airbags reduce the risk of injury to the areas of the body facing the impact. ■

How the side airbags work

When fully inflated, the side airbags reduce the risk of head or chest injury.



Fig. 100 Side airbag in inflated condition

In certain types of **side collisions** the side airbag is triggered on the impact side of the vehicle ⇒ fig. 100.

In certain types of accident the front airbags and the side airbags may be triggered together.

When the system is triggered, the airbag is filled with propellant gas.

In order to provide the desired extra protection in an accident, the airbags have to inflate extremely rapidly (within fractions of a second). The airbag releases a fine dust when it inflates. This is quite normal and does not mean there is a fire in the vehicle.

The fully deployed airbags cushion the impact of the occupants and help to reduce the risk of injury to the head and upper part of the body on the side facing the door. ■

Important safety notes on the side airbag system

There are a number of safety points concerning the airbag system which you should remember. This will help to reduce the risk of injury in an accident.

WARNING

- If you do not wear a seat belt, if you lean forward, or are not seated correctly while the vehicle is in motion, you are at greater risk of injury should the side airbag system be triggered in an accident.
- If children are not seated correctly, they are at greater risk of injury in an accident. This is particularly the case if the child is travelling on the front passenger's seat and the airbag system is triggered in an accident. This could result in serious or potentially fatal injury ⇒ page 122, "Child safety".
- It is also important not to attach any accessories (such as cup holders) to the doors. This would impair the protection offered by the side airbags.
- The sensors for the airbags are located in the front doors. You must therefore not make any modifications to the doors or door trim (e.g. retrofitting loudspeakers), as this could impair the function of the side airbags. Any damage to the front doors could lead to faults in the system. Repairs or any other work on the front doors must therefore always be carried out by a qualified workshop.
- Do not apply excessive force to the sides of the backrests (such as hard knocks or kicks), as this could damage parts of the system. The side airbags could then fail to operate when required.
- If you intend to fit protective covers over the seats, these must be of the specific type approved for use on Audi seats with side airbags. Conventional seat covers would obstruct the side airbag when it inflates out of the backrest, and seriously reduce the airbag's effectiveness.

WARNING (continued)

- Any damage to the original seat upholstery or around the seams of the side airbag units must be repaired immediately by a qualified workshop.
- Any work involving the side airbag system or removal and installation of the airbag components for other repairs (such as repairs to the seats) should always be performed by a qualified workshop. Otherwise the airbag system may fail to work properly. ■

WARNING

- Never install a rearward-facing child safety seat on the front passenger's seat unless the front passenger's airbag has been deactivated – this can result in potentially fatal injuries to the child ⇒ *page 123*.
- Make sure that the front passenger's airbag is reactivated by means of the key-operated switch as soon as the child seat is no longer needed on the front passenger's seat. ■

Applies to vehicles: with key-operated switch for front passenger's airbag

Key-operated switch for front passenger's airbag

The front passenger's airbag can be deactivated with the key-operated switch.

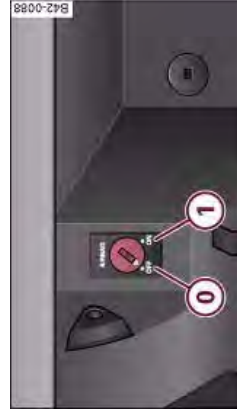

Fig. 101 Key-operated switch for deactivating front passenger's airbag

Deactivating the airbags**Deactivating airbags**

If airbags have been deactivated, they should be reactivated as soon as possible so that they can continue to give the required protection.

There are two ways of deactivating the airbags: you can deactivate the front passenger's airbag yourself by means of the key-operated switch ⇒ *page 120*. The other airbags can be deactivated by your Audi R8 dealer.

Deactivating front passenger's airbag when a child safety seat is in use

If you have no alternative but to install a rearward-facing child safety seat on the front passenger's seat you must deactivate the front passenger's airbag beforehand.

Monitoring of airbag system

The airbag warning lamp will light up for a few seconds every time the ignition is switched on.



Fig. 102 Lamp indicates that front passenger's airbag has been deactivated via key-operated switch

WARNING (continued)

- It is the driver's responsibility to ensure that the key-operated switch is set to the correct position. ■

The key-operated switch for deactivating the front passenger's airbag is located in the glove box ⇒ *page 120*, fig. 101.

- To deactivate the front passenger's airbag, insert the ignition key in the switch and turn it to position ①.
- The front passenger's airbag can be reactivated by turning the key to position ①.

If the front passenger's airbag has been deactivated via the key-operated switch, the indicator lamp "PASSENGER AIRBAG OFF" will light up constantly as a reminder ⇒ *page 121*, fig. 102. Please refer also to the description of the **AIRBAG** warning lamp in the instrument cluster ⇒ *page 17*.

WARNING

- If you have no alternative but to install a rearward-facing child seat on the front passenger's seat, the front passenger's airbag must be deactivated beforehand – otherwise this can result in potentially fatal injuries to the child.
- If you have deactivated the front passenger's airbag, reactivate it as soon as the child seat is no longer needed so that the airbag can continue to give the required protection.

Child safety

Points to remember if children are travelling in the car

Introduction

The physical principles involved and the forces acting in a collision apply to children just as much as adults ⇒ *page 110*, "Forces acting in a collision". But, unlike adults, children do not have fully developed muscle and bone structures. This means that children are subject to a greater risk of injury.

To reduce this risk, children must always use special child restraint systems when travelling in the car.

Use only child restraint systems which are officially approved under the European standard ECE R 44 and are suitable for the child. ECE R refers to the Economic Commission of Europe Recommendation, which categorises child restraint systems in 5 groups ⇒ *page 123*, "Child seat categories". Child restraints that have been tested and approved under the ECE R 44 standard bear the ECE-R 44 test mark on the seat (the letter E in a circle with the test number below it).

We recommend using child restraint systems from the range of Audi Genuine Accessories available from Audi R8 dealers. The "Huckepack" range includes suitable restraint systems for all ages. These systems have been specially designed for use in Audi vehicles and comply with the ECE R 44 standard.

Follow the manufacturer's instructions and observe any statutory requirements when installing and using child restraints ⇒  in "Important safety notes for using child safety seats". ■

Important safety notes for using child safety seats

Correct use of child safety seats can help to reduce the risk of injury in an accident.

WARNING

- All vehicle occupants, especially children, must wear a seat belt while the vehicle is in motion.
- Children who are less than 1.5 metres tall must not wear a normal seat belt without a child restraint, as this could cause injuries to the abdominal and neck areas.
- Babies and children must never travel on another occupant's lap.
- A suitable child safety seat can protect your child ⇒ *page 123*, "Child safety seats".
- Never allow two children to occupy one child safety seat.
- Never leave a child without supervision in a child safety seat.
- Never allow a child to travel in the car without a suitable child restraint.
- Never allow a child to stand up or kneel on a seat while the car is moving. In an accident, the child could be catapulted through the car, causing possibly fatal injuries to itself and other occupants.
- If children lean forward or are otherwise out of position when the car is moving, they are at greater risk of injury in an accident. This is especially the case if the airbag is activated during an accident. There is then a risk of serious or potentially fatal injury.
- To ensure proper protection, it is important to wear the seat belts in the correct position ⇒ *page 112*, "How to wear seat belts properly". Always check that the belt is properly positioned

WARNING (continued)

according to the instructions provided by the manufacturer of the child safety seat. Incorrectly worn seat belts can give rise to injuries even in a minor collision.

- Never install a rearward-facing child safety seat on the front passenger's seat unless the front passenger's airbag has been deactivated.
- Extra caution is advised if you are installing a child safety seat using the same mounting bolts as the existing car seat belts. The bolts must be screwed in all the way to the full depth of the mounting holes and tightened to a torque of 50 Nm. Failure to observe this precaution could result in potentially fatal injury. We recommend having the installation performed by a qualified workshop.
- Do not use a rearward-facing child safety seat on the front passenger's seat unless the front passenger's airbag has been deactivated. The child seat would be directly in the path of the airbag as it inflates, and the child could sustain serious or fatal injuries if the airbag were to be deployed.
- However, if you have no alternative but to use a rearward-facing child seat on the front passenger's seat, the front passenger's airbag must be deactivated beforehand by means of the key-operated switch. Failure to observe this precaution could result in serious or potentially fatal injury.
- Make sure that the front passenger's airbag is reactivated by means of the key-operated switch as soon as the child seat is no longer needed on the front passenger's seat.
- When using a child safety seat of the type which faces in the direction of travel, the front passenger's seat must be moved back to the rearmost position. ■

Child safety seats**Child seat categories**

Only use child restraint systems that are officially approved and suitable for the child.

Child restraint systems are covered by the European standard ECE R 44 (issued by the Economic Commission of Europe).

The child seats are divided into 5 categories:

Category	Weight	
0	0 - 10 kg	⇒ page 124
0+	up to 13 kg	⇒ page 124
1	9 - 18 kg	⇒ page 124
2	15 - 25 kg	⇒ page 125
3	22 - 36 kg	⇒ page 125

Children who are taller than 1.5 metres can use the existing seat belts without a booster cushion.

Child restraints that have been tested and approved under the ECE R 44 standard bear the ECE-R 44 test mark on the seat (the letter E in a circle with the test number below it). ■

Child safety seat: category 0 / 0+

A suitable child safety seat and a correctly worn seat belt can protect your child.



Fig. 103 Child safety seat: Category 0 / 0+

Babies up to about 9 months old/ 10 kg and infants up to about 18 months old/ 13 kg are best protected by child safety seats that can be adjusted to a horizontal position ⇒ fig. 103.

Follow the manufacturer's instructions and observe any statutory requirements when installing and using child restraints ⇒ page 122. "Important safety notes for using child safety seats".

	WARNING
Never install a rearward-facing child safety seat on the front passenger's seat if the front passenger's airbag has not been deactivated ⇒ page 122. This can result in serious or possibly fatal injury. ■	

Child safety seats: category 1

A suitable child safety seat and a correctly worn seat belt can protect your child.

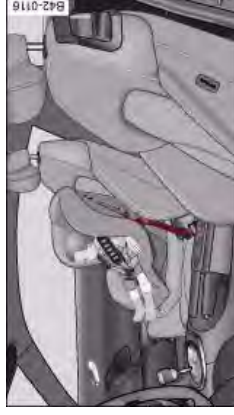

Fig. 104 A category 1 forward-facing child seat fitted on the passenger seat

Babies and small children up to about 4 years of age weighing between 9 and 18 kg are best protected by child safety seats of the type where the child faces the front of the vehicle ⇒ fig. 104.

Follow the manufacturer's instructions and observe any statutory requirements when installing and using child restraints ⇒ page 122. "Important safety notes for using child safety seats".

	WARNING
Never install a rearward-facing child safety seat on the front passenger's seat if the front passenger's airbag has not been deactivated ⇒ page 122. This can result in serious or possibly fatal injury. ■	

Child safety seats: category 2/3

A suitable child safety seat and a correctly worn seat belt can protect your child.



Fig. 105 A category 2/3 forward-facing child seat (with backrest) fitted on the passenger seat



Fig. 106 A category 3 forward-facing child seat (without backrest) fitted on the passenger seat

Children up to about 12 years of age weighing between 15 and 36 kg but less than 1.5 metres tall are best protected by a child safety seat in conjunction with the three-point seat belts ⇒ fig. 105.

Follow the manufacturer's instructions and observe any statutory requirements when installing and using child restraints ⇒ page 122, "important safety notes for using child safety seats".

WARNING

The diagonal part of the belt should be positioned roughly over the centre of the shoulder and fit closely against the upper part of the body. It must never be allowed to run across the neck. The lap part of the belt should fit closely over the hips. It must not be positioned over the stomach. Pull the belt tight if necessary to take up any slack.



Note

We recommend that you fit child safety seats with backrests. ■

Fitting child safety seats

General information



Fig. 107 Example of an approval number on a child safety seat

Label on a child safety seat ⇒ fig. 107

- ① Approval number
 - ② Manufacturer's serial number.
- The label also shows information on the use and weight class of the child seat.

List of recommended child safety seats

Weight class	Identification "Huckepack"	Audi Genuine Accessories catalogue number	Manufacturer	Model	Approval number
0+ (up to 13 kg)	G0 Plus	00A.019.900.A	Britax Römer	Baby-Safe Plus	E1 033 01146
1 (9 to 18 kg)	G1 ISOFIX Duo Plus	00A.019.909.B	Britax Römer	Duo Plus	E1 033 01133
2 (15 to 25 kg)	G3 Plus	00A.019.906	Britax Römer	Kid Plus	E1 033 01169
3 (22 to 36 kg)	G3 Plus	00A.019.906	Britax Römer	Kid Plus	E1 033 01169

For the current range of child seats from Audi Genuine Accessories visit: <http://www.audi.com>

Extended list of recommended child restraint systems

Weight class	Identification	Catalogue number	Manufacturer	Model / Mode of securing seat	Approval number
1 (9 to 18 kg)	ISOFIX FWF	4590.xx., 4610.xx ¹⁾	FAIR	FAIR G0/ ISOFIX forward-facing with special platform type SP (FWF)	E4 044 43513
	Universal	4590.xx ¹⁾	FAIR	FAIR G0/ ISOFIX standard three-point seat belt	E4 034 43416

¹⁾manufacturer details:

Company: FAIR srl

Address: Strada della Cisa 249/251, I- 42040 Sorbolo Levante di Brescello (RE) / Italy.
<http://www.fairbimbofix.com> ■

Possible alternatives for securing a child safety seat

A child safety seat can be secured on the passenger's seat.

The following alternatives are available for safely securing a child safety seat on the passenger seat:

- Child safety seats of the categories **0 to 3** can be secured with the standard three-point seat belts.
- Child safety seats of the categories **0, 0+ and 1** with the "ISOFIX" system can be secured without seat belts using the "ISOFIX" retainers ⇒ *page 128*.

Compatibility of vehicle seat positions for child safety seats (according to EC directive 77/541):

Weight class	Front passenger's seat
0, 0+	u, a, b, c
1	u, a, b, c
2	u, a
3	u, a

u "universally compatible"

- a The front passenger's *backrest* must be set as far forward as possible or adapted to the child safety seat as required, and the seat height must be adjusted to its highest position.
- b The front passenger's seat can be equipped with optional "ISOFIX" retainers (this does not apply to bucket seats).
- c The front passenger's airbag must be deactivated if a rearward-facing child seat is used.

! WARNING

While the vehicle is moving, children must always be protected with a restraint system which is suited to their age, height and weight. Please refer to the chapter "Child seat categories".

- Never install a rearward-facing child safety seat on the front passenger's seat unless the front passenger's airbag has been

WARNING (continued)

deactivated. This could result in potentially fatal injuries. Deactivating the passenger's airbag. Please refer to the chapter "Deactivating airbags".

- Note the important information and warnings concerning the use of child safety seats found in the chapter "Important safety notes when using child safety seats" and the installation instructions provided by the manufacturer of the child safety seat. ■

Applies to vehicles with ISOFIX system

"ISOFIX" child seat mounting system

Child safety seats with the "ISOFIX" system can be secured quickly, easily and safely.



Fig. 108 Retainers (B) for ISOFIX child safety seats between backrest and seat cushion of passenger seat



Fig. 109 The ISOFIX child safety seat can be secured after fitting the protective sleeves.

When removing or fitting the child safety seat, please be sure to follow the manufacturer's instructions.

- Fit the protective sleeves (A) onto the retainers (B) between the backrest and the seat cushion ⇒ fig. 108.
- Push the mountings on the child safety seat into the protective sleeves until they engage audibly (2x) ⇒ fig. 109.
- Pull on the child safety seat to check whether both catches have engaged properly.

Child safety seats with the "ISOFIX" system can be secured quickly, easily and safely on the passenger seat. Detailed fitting instructions are supplied with the child safety seat. Child seats with "ISOFIX" mountings are available from Audi R8 dealers and specialist retailers.

WARNING

The retainers used here are specially designed for child safety seats with "ISOFIX" mountings. Do not attempt to secure other types of child safety seat, seat belts or other objects with these retainers – this could result in serious or possibly fatal injury. ■

Technical data

Self-help

General maintenance

Driving tips

Safety

Controls



Driving tips

131



Intelligent technology

Electronic stabilisation program (ESP)

The Electronic Stabilisation Program increases the car's stability.



Fig. 110 Centre console with ESP switch

Description

The anti-lock brake system (ABS), the electronic differential lock (EDL) and the traction control system (ASR) are all integrated into the electronic stabilisation program (ESP). The ESP is designed to enhance the control over the vehicle in critical handling situations, such as when accelerating and cornering. It reduces the tendency to skid at all speeds under all road conditions and improves the stability and roadholding of the vehicle. ESP helps the car to start moving, accelerate and climb a gradient in slippery conditions where this may otherwise be difficult or even impossible. The ESP is switched on automatically when the engine is started. It should normally be left switched on at all times for optimum car stability.

Driving situations

If the car is oversteering (rear wheels losing grip first) the ESP mainly brakes the outside front wheel; if the car is understeering (front wheels losing grip first), the ESP brakes the inside rear wheel and possibly also other wheels. This automatic brake application is accompanied by characteristic noises.

If, when braking, one of the wheels is turning too slowly in relation to the road speed and is close to locking up, the system will reduce the pressure in the brake line to this wheel. The driver is made aware of this control process by a pulsating of the brake pedal and accompanying noise. In this situation it is important to keep the brake pedal fully depressed so the ABS can regulate the brake application - **do not** "pump" the brake pedal. However, the ABS will not necessarily guarantee shorter *stopping distances* in all conditions. For instance, on loose gravel or fresh snow on top of an icy surface the stopping distance with ABS may even be slightly *longer*.

Whenever it detects a significant *difference in the speed of the driven wheels of one axle* (for example, if the road is slippery *on one side*) the electronic differential lock (EDL) applies the brake to slow down the spinning wheel so that more of the power is directed to the other wheels. This function is active up to about 100 km/h. The brake system will make noises while it is working.

If one wheel has less grip and starts spinning (for instance, if one of the driven wheels is on ice), press the accelerator *hard* until the car starts moving.

If the wheels start to spin, the traction control system (ASR) automatically reduces the engine torque to match the amount of grip available.

Activating the sport mode

If required (for instance if you want to use the launch control), you can switch the traction control system (ASR) and electronic stabilisation program (ESP) to sport mode by pressing the **[ESP]** button once. The ESP warning lamp will light up and the message **ASR off** will appear in the driver information system display. The amount of wheel slip is regulated according to the road speed. You should only use this feature if your driving ability and traffic conditions allow you to do so safely. ▲

Switching off the ESP and traction control system (ASR)

To switch off the ASR and ESP in certain situations (e.g. when driving with snow chains, in deep snow, or on a loose surface, or when rocking the car backwards and forwards to free it from mud) press the **[ESP]** button for longer than 3 seconds. The ESP warning lamp will light up and the message **ESP switched off** will appear in the driver information system display. You should only use this feature if your driving ability and traffic conditions allow you to do so safely.

Switching on the ESP/traction control system (ASR)

To activate the ASR/ESP, press the **[ESP]** button again.

Overheating of the brakes

To prevent the disc brake of a braked wheel from overheating, the EDL cuts out automatically on the wheel in question if subjected to excessive loads. The car remains operational and will behave in the same way as a car without EDL.

The EDL will switch on again automatically when the brake has cooled down.

WARNING

- The grip provided by the ESP, ABS, EDL and ASR systems is still subject to the physical limits of adhesion. Always bear this in mind, especially on wet or slippery roads. If you notice the systems cutting in, you should reduce your speed immediately to suit the road and traffic conditions. Do not let the extra safety features tempt you into taking any risks when driving – this can cause accidents.
- Please remember that the accident risk always increases if you drive too fast, especially in corners or on a slippery road, or if you follow too close behind the vehicle in front of you. Please bear in mind that even ESP, ABS, EDL and ASR cannot compensate for the increased accident risk.

WARNING (continued)

- When accelerating on a uniformly slippery surface (for instance all four wheels on ice or snow), press the accelerator gradually and carefully. The driven wheels may otherwise start to spin (in spite of the EDL), which would impair the car's stability and could lead to an accident.
- Please note that, when the traction control system (ASR) or ASR/ESP is switched off, the driven wheels may start to spin, causing the vehicle to lose grip, in particular on slippery or wet roads - danger of skidding!

Note

- In the event of a malfunction in the rear spoiler system or in the Audi magnetic ride, it may not be possible to switch off the traction control system (ASR) or ASR/ESP, or the ASR/ESP may be reactivated automatically from the deactivated status.
- If a malfunction should occur in the EDL, this is indicated by a warning lamp ⇒ page 19.
- Some racing circuits (e.g. with banked curves) can affect the behaviour of the ESP. ■

Controls

Safety

Driving tips

General maintenance

Self-help

Technical data

Rear spoiler

The automatic rear spoiler increases the car's stability.



Fig. 111 Switch for rear spoiler

The rear spoiler can be extended or retracted manually or automatically.

Automatic mode (normal operation)

- Automatic extension: The rear spoiler is automatically extended at road speeds above approximately 100 km/h.
- Automatic retraction: The rear spoiler is automatically retracted at road speeds below approximately 35 km/h.

Manual mode

- Manual extension: Press the switch \Rightarrow page 134, fig. 111 briefly to extend the rear spoiler all the way out.
 - Manual retraction: At road speeds up to about 20 km/h, press and hold the switch to retract the rear spoiler. At road speeds between 20 km/h and 100 km/h, press the switch briefly to retract the rear spoiler all the way back.
- Manual mode will be deactivated for up to 2.5 minutes after 15 extension and retraction cycles. The system switches to automatic mode at road speeds above approximately 100 km/h.

WARNING

- If the rear spoiler warning lamp lights up, the rear spoiler may have failed to extend. In this case, the car's handling may be different at high speeds. We recommend you not to exceed 140 km/h. Drive to a qualified workshop as soon as possible and have the fault corrected.
- When extending or retracting the rear spoiler, please make sure that no persons or objects are close to the moving spoiler - risk of injury!

Caution

- If you need to push the vehicle, never put your weight on the rear spoiler - Risk of damage!
- Do not operate the rear spoiler manually when the engine lid is open - Risk of damage!

Note

Clean the rear spoiler housing every 2 to 3 months. The rear spoiler housing must be free of ice, snow and leaves in order to operate correctly. ■

Brakes

New brake pads

New brake pads do not give full braking effect for the first 400 km, they must first be "bedded in". However, you can compensate for the slightly reduced braking effect by applying more pressure on the brake pedal. Avoid placing a heavy load on the brakes during the running-in period. ▲

Wear

The rate of wear on the **brake pads** depends a great deal on how you drive and the conditions in which the vehicle is operated. Negative factors are, for instance, city traffic, frequent short trips or hard driving with abrupt starts and stops.

Wet roads; road salt

When you are driving at a speed *higher than* 70 km/h and have the windshield wipers *switched on* (at or above intermittent setting 4) the brake pads are very briefly brought into contact with the brake discs. This automatic process which goes unnoticed by the driver is carried out at regular intervals and is intended to improve braking response in wet conditions.

In certain conditions, such as in heavy rain, or after washing the car or driving through water, the full braking effect can be delayed by moisture (or in winter by ice) on the discs and brake pads. The brakes should be "dried" by pressing the pedal to restore full braking effect.

The effectiveness of the brakes can also be temporarily reduced if the car is driven for some distance without using the brakes when there is a lot of salt on the road in winter. The layer of salt that accumulates on the discs and pads can be removed with a few cautious brake applications.

Corrosion

There may be a tendency for dirt to build up on the brake pads and corrosion to form on the discs if the car is used infrequently, or if you only drive low mileages without using the brakes very much.

If the brakes are not used frequently, or if corrosion has formed on the discs, it is advisable to clean off the pads and discs by braking firmly a few times from a moderately high speed ⇒ .

Faults in the brake system

If the brake pedal travel should ever increase *suddenly*, this may mean that one of the two brake circuits has failed. Drive immediately to the nearest qualified workshop and have the fault rectified.

On the way to the dealer, be prepared to use more pressure on the brake pedal and allow for longer stopping distances.

Low brake fluid level

Malfunctions can occur in the brake system if the brake fluid level is too low. The brake fluid level is monitored electronically.

Brake servo

The brake servo amplifies the pressure you apply to the brake pedal. It only works when the engine is running.



WARNING

- When applying the brakes to clean off deposits on the pads and discs, select a clear, dry road. Be sure not to inconvenience or endanger other road users; do not risk an accident.
- Never let the car coast with the engine switched off (this can cause accidents).



Caution

- Never let the brakes "drag" by leaving your foot on the pedal when you do not really intend to brake. This overheats the brakes, resulting in longer stopping distances and greater wear.
- Before driving down a long, steep gradient, it is advisable to reduce speed and select a lower gear. In this way you will make use of the engine braking effect and relieve the load on the brakes. If you still have to use the brakes, it is better to brake firmly at intervals than to apply the brakes continuously.



Note

- If the brake servo is out of action due to a malfunction, or if the car has to be towed, you will have to press the brake pedal considerably harder to make up for the lack of servo assistance.
- If you wish to equip the car with accessories such as a front spoiler or wheel covers, it is important that the flow of air to the

front wheels is not obstructed, otherwise the brakes can overheat. ■

Power steering

The power steering assists the driver when turning the steering wheel (with the engine running).

The power steering assists the driver by reducing the force needed to turn the steering wheel.

The power steering does not function when the engine is switched off. In this case the steering wheel is very hard to turn.

If the steering is held at its *turning limit* when the car is stationary, this will place an excessive load on the power steering system. In this case, the power steering system will make noises. It will also reduce the idling speed of the engine.



Caution

Do not keep the steering in the full-lock position for longer than 15 seconds when the engine is running – this could cause damage to the power steering system.



Note

- If the power steering should fail at any time or the engine is switched off (for instance when being towed), the car can still be steered. However, more effort will be required to turn the steering wheel.
- If the system is leaking or malfunctioning, please take the car to a qualified workshop as soon as possible.
- The power steering requires a special hydraulic fluid. The container for the fluid is located in the engine compartment. The correct fluid level in the reservoir is important for the power steering to function properly. The hydraulic fluid level is checked at the Inspection Service. ■

Four-wheel drive (quattro®)

On quattro models the engine power is distributed to all four wheels

General notes

On four-wheel drive vehicles, the engine power is distributed to all four wheels. The distribution of power is controlled automatically according to your driving style and the road conditions. Also refer to ⇒ page 132.

Winter tyres

Thanks to its four-wheel drive, your car will have plenty of *traction* in winter conditions, even with the standard tyres. Nevertheless, we still recommend that winter tyres should be fitted *on all four wheels* when winter road conditions are expected, mainly because this will give a better *braking response*.

Snow chains

On roads where snow chains are mandatory, this also applies to cars with four-wheel drive ⇒ page 171, "Snow chains".

Replacing tyres

The dimensions of the wheels and tyres used on four-wheel drive vehicles must comply with the manufacturer's specifications ⇒ page 168, "Replacing wheels and tyres".

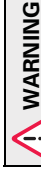

WARNING

- Even with four-wheel drive, you should always adjust your speed to suit the conditions. Do not let the extra safety provided tempt you into taking any risks when driving – this can cause accidents.
- The braking ability of your car is limited by the grip of the tyres. In this respect, your car is no different from a car without four-wheel drive. So do not be tempted to drive too fast on icy or slippery roads.

⚠ WARNING (continued)

pery roads just because the car still has good acceleration in these conditions (accident risk).

- On wet roads bear in mind that the front wheels may start to “aquaplane” and lose contact with the road if the car is driven too fast. If this should happen, there will be no sudden increase in engine speed to warn the driver, as with a front-wheel drive car. So do not drive too fast in the wet: adjust your speed to suit the conditions (accident risk). ■

Dry sump lubrication system

Large lateral and longitudinal forces act on the engine and vehicle when a sporty driving style is adopted. A dry sump system ensures that the engine continues to be supplied with oil and lubricated optimally under these conditions.

In a “normal” car, the oil is stored in the oil sump and is pumped from there to the lubrication points inside the engine. The oil then flows from there back into the oil sump. In extreme situations this can cause air to be sucked into the oil pump with the result that the oil pressure is no longer high enough.

In a dry sump lubrication system, the oil is stored in a separate oil tank instead of the oil sump (which is “dry”). While one pump sends oil to the engine, a second pump returns the oil from the engine to the oil tank. The tall and slim shape of the oil tank means that the oil pressure can be kept constant even in extreme conditions.

In addition, the oil sump is much lower on vehicles with dry sump lubrication. This means that the engine can also be arranged lower down for a lower centre of gravity and improved handling. ■

Controls

Safety

Driving tips

General maintenance

Self-help

Technical data

Your vehicle and the environment

Your vehicle and the environment

Running in

A new vehicle should be run in over a distance of 2,500 km. During the first 1,000 km do not use full throttle and do not exceed an engine speed of 6,000 rpm. From 1,000 to 2,000 km you should also avoid using full throttle. From 2,000 to 2,500 km you can then increase engine speed gradually and briefly to 8,250 rpm.

During its first few hours of running, the internal friction in the engine is greater than later on when all the moving parts have bedded down.

How the vehicle is driven for the first 2,500 km also influences the engine quality. After the first 2,500 km you should continue driving at moderate engine speeds, in particular when the engine is cold. This helps to reduce wear and tear on the engine and increases the potential mileage which can be covered by the engine.

You should also avoid driving with the engine speed too low. Change down to a lower gear when the engine no longer runs "smoothly". Excessively high engine speeds are prevented by an automatic rev limiter. ■

Emission control systems

The vehicle must only be used with unleaded petrol, otherwise the catalytic converter will be destroyed.

Never run the tank completely dry. The irregular fuel supply can cause misfiring, which would allow unburnt fuel to enter the exhaust system, which could cause overheating and damage the catalytic converter.



WARNING

- Because of the high temperatures which can occur in the emission control system, do not park the vehicle where the exhaust can come into contact with flammable materials under the car (e.g. on grass or at the forest edge). - Fire hazard!
- Do not apply any underseal agents in the area around the exhaust system - fire hazard! ■

Driving abroad

Unleaded petrol

A car with catalytic converter must *not* be run with leaded petrol ⇒ *page 138*. Before driving abroad make sure that **unleaded petrol** is available there.

Changing over headlight dip settings

The asymmetric low beams of the headlights are designed to light up the near side of the road more intensely. If you drive in a country where traffic drives on the opposite side of the road to the home country, this will dazzle oncoming traffic.

The headlight dip settings must be changed to avoid dazzling oncoming traffic. For safety reasons, you should have the dip settings changed by a qualified workshop.

For further information about changing the dip settings on xenon* headlights, please contact your Audi R8 dealer or other qualified workshop. ■

Sporty driving

Letting the engine warm up and cool down

You can reduce the amount of wear and tear on your vehicle during a sporty driving session simply by adopting a more restrained driving style while the engine is warming up and cooling down.

You should allow the engine to warm up by keeping the engine speed below 7000 rpm until the engine oil reaches at least 90 °C. In addition, the tyres will not develop their full grip potential until they have had a chance to warm up on the road.

Even though the engine continues to be cooled after you switch it off, it is particularly important to give it time to cool down before parking. The engine, brakes, exhaust system and gearbox will all reach very high temperatures when you adopt a sporty driving style. Before you park the vehicle, allow it to cool down to normal temperature by driving at moderate rpm speeds for several miles. ■

Driving on a racing circuit

Before you take your car out on a racing circuit, please ensure that it is in perfect condition. You should check the tyre tread and brake pads for wear. It's also a good idea to increase the tyre pressure by 0.3 bar.

The oil consumption may be slightly higher than "normal" when driving on a racing circuit ⇒ *page 157*.

You should always check your vehicle after driving hard. Are the brake pads ok? Do you notice any problems with the tyres (e.g. tread worn, blistering, etc.)? Are the air intakes free of leaves and deposits? Is the oil level ok?

Your Audi R8 dealer will be glad to carry out an inspection before and after you use the car on a racing circuit.



Note

- Some racing circuits (e.g. with banked curves) can affect the behaviour of the ESP.
- Driving the car on a racing circuit places a heavy load on all parts of the vehicle. This can result in increased wear and tear. ■

Environmental compatibility

Environmental protection is a top priority in the design, choice of materials and production of your new Audi. Particular importance has been attached to the following aspects:

Design measures for economical recycling

- Joints and connections designed for ease of dismantling
- Modular construction to facilitate dismantling
- Increased use of single-grade materials
- Plastic parts and elastomers are labelled in accordance with ISO 1043, ISO 11469 and ISO 1629

Choice of materials

- Nearly all materials used can be recycled
- Similar types of plastics grouped together for easy recycling
- Recycled materials used in manufacture
- Reduced vapour emissions from plastics
- CFC-free refrigerant in air conditioner

Compliance with the laws prohibiting the use of:

- Cadmium
- Asbestos
- Lead
- Mercury
- Chrome VI

Controls

Safety

Driving tips

General maintenance

Self-help

Technical data

Manufacturing methods

- Plastic components made from recycled materials
- Solvent-free cavity sealing
- Solvent-free wax for protecting the vehicles in transit
- Solvent-free adhesives
- No CFCs used in production
- Surplus materials used extensively for energy conversion and building materials
- Overall water consumption reduced
- Heat recovery systems
- Water-soluble paint ■



General maintenance

143



Care of vehicle and cleaning

General notes

Regular care helps to maintain the value of the vehicle.

Regular and careful care helps to **maintain the value** of the vehicle. This may also be one of the requirements for upholding any warranty claims in the event of corrosion or paint defects.

Audi R8 dealers and specialist retailers carry stocks of suitable **car care products**. Please follow the instructions for use on the packaging.

WARNING

- **Cleaning products and other materials used for car care can damage health if misused.**
- **Car care materials can contain toxic substances and must always be kept in a safe place out of reach of children.**



For the sake of the environment

- When purchasing car care products, try to select ones which are not harmful to the environment.
- Surplus cleaning materials should not be disposed of together with ordinary household waste. ■

Care of exterior

Washing the car

The longer substances like insects, bird droppings, resinous tree sap, road dirt, industrial deposits, tar, soot or road salt and other aggressive materials remain on the vehicle, the more damage they

do to the paintwork. High temperatures (for instance in strong sunlight) further intensify the corrosive effect.

After the period when salt is put on the roads it is important to have the **underside** of the vehicle washed thoroughly.

Automatic car washes

Before going through a car wash, be sure to take the usual precautions such as closing the windows. If the vehicle is fitted with special accessories such as spoilers or a two-way radio aerial, etc., it is advisable to consult the car wash operator ⇒ .

It is best to use a car wash without revolving brushes if possible.

Washing your car with a high-pressure cleaner

When cleaning the vehicle with a high-pressure cleaner, always follow the operating instructions for the equipment. This applies particularly to the **operating pressure** and the **spraying distance**. Do not hold the spray nozzle too close to soft materials, such as rubber hoses or seals.

Do not use a nozzle that sprays the water out in a **direct stream** or one that has a **rotating jet** for forcing off dirt.

Washing the car by hand

When washing the car by hand, use plenty of water to soften the dirt first, and rinse off as well as possible.

Then clean the vehicle with a soft **sponge, glove or brush**, using only slight pressure. You should start on the roof and work down. Special **car shampoo** should only be used for very persistent dirt.

Rinse the sponge or glove thoroughly and often.

Wheels, sills and similar should be cleaned last. Use a second sponge for this. ▲



- WARNING**
- Do not wash the vehicle with the ignition switched on – risk of accident.
 - Do not clean the underside of the car or inside the wheel arches without protecting your hands and arms. You may cut yourself on sharp metal parts.
 - Take care when washing the car during the winter: moisture and ice on the brakes may affect braking efficiency – this could cause an accident.



- Caution**
- Compare the track width of your vehicle with the distance between the guide rails for the wheels in the car wash. Otherwise there may be a risk of damaging the wheel rims and tyres.
 - Compare the ground clearance of your vehicle with the height of the guide rails for the wheels in the car wash to prevent any damage to the underside.
 - Compare the width of your vehicle with the available width when entering and driving through the car wash.
 - Retract the exterior mirrors to avoid damage. Electrically retractable exterior mirrors must NOT be folded in or out by hand. Always use the electrical power control.
 - Do not wash the vehicle in direct sunlight – otherwise the paint can be damaged.
 - Do not use insect sponges, or abrasive household sponges, etc. – they can damage the surfaces.
 - The headlights should only be washed with water – do not wipe them with a dry cloth or sponge. It is best to use soapy water.
 - Never wash tyres with a jet that sprays the water out in a direct stream. This could damage the tyres – even if the spray is kept at a distance and only used for a very short time.



For the sake of the environment

The car should only be washed in special wash bays. This prevents oily water from getting into the public drains. In some districts, washing vehicles anywhere else may be prohibited. ■

Waxing and polishing

Waxing

Waxing protects the paintwork. It is time to apply a good coat of **wax** when water no longer **forms droplets** and rolls off the clean paintwork.

Even if a **wax solution** is used regularly in the car wash, it is advisable to protect the paint with a coat of wax at least twice a year. In the summer, you will find it is much easier to remove dead insects (which accumulate on the bumper and front lid) if the car has been waxed *recently*.

Polishing

Polishing is only necessary if the paint has lost its shine, and the gloss cannot be brought back by putting on wax.

The car must be waxed **after** polishing if the polish used does not contain wax compounds to seal the paint.



Caution

Matt painted and plastic parts must not be treated with wax or polish. ■

Ornamental trim and moldings

The metal brightwork on the body is made of aluminium rather than chrome (for environmental reasons). ▲

Controls

Safety

Driving tips

General maintenance

Self-help

Technical data

Dirt or marks on the trim mouldings should be removed with an **acid-free cleaning agent** (do not use a chrome cleaner). Body polish is also unsuitable for use on trim mouldings. The intensive cleaning fluids often used before the car goes into a car wash may contain alkaline substances, which can cause dull or milky patches when they dry out.

Audi R8 dealers carry stocks of cleaning products which have been tested and approved for use on your vehicle and which are not harmful to the environment. ■

Plastic parts

Plastic parts will come clean with regular washing. If this is not sufficient, plastic parts should only be treated with a special solvent-free **plastic cleaning agent**. Do not use paint cleaners, polishes or wax on plastic parts. ■

Applies to vehicles: with carbon parts

Carbon parts

The carbon parts on your vehicle have a painted surface. They do not need any special care and are cleaned just like any other painted part ⇒ *page 144*. ■

Paint damage

Minor damage to the paint, such as scratches or stone chips, should be touched up *without delay* before the metal starts to corrode. Suitable **touch-up brushes** or **sprays** for your car can be obtained from an Audi R8 dealer.

The number of the original paint finish on the vehicle is given on the data sticker ⇒ *page 196*.

If corrosion is already visible it must be thoroughly removed by a qualified workshop. ■

Windows

Clear vision is an essential safety factor.

The windshield must not be cleaned with insect remover or wax, otherwise the windshield wipers will not function properly (juddering).

Traces of rubber, oil, grease or silicone can be removed with a **window cleaning solution** or a **silicone remover**. Wax residue can only be removed with a special cleaner. Your Audi R8 dealer will be able to provide you with more detailed information.

The windows should also be cleaned on the inside at regular intervals.

Use a separate cloth or chamois to dry the windows. Cloths used for waxing and polishing contain residues that will cause smears on the glass.



WARNING

Do not use water-repellent coatings on the windshield. In bad visibility conditions such as light rain, low sun or when driving at night these coatings can cause increased dazzle, which is a serious safety hazard. Such coatings can also cause the wiper blades to judder.



Caution

- Remove snow and ice from windows and mirrors with a **plastic scraper** only. To avoid scratches caused by dirt on the glass, the scraper should only be pushed in one direction and not moved to and fro.

- The heating element for the rear window is located on the inner side of the window. To avoid damaging the heating element, do not put stickers on the inner side of the window.
- Never use warm or hot water to remove snow and ice from windows and mirrors. This could cause the glass to crack! ■

Rubber seals (weatherstrips)

The weatherstrips on the doors, windows, engine lid and luggage lid will remain pliable and last longer if they are occasionally treated with a suitable care product (for example silicone spray). This will also prevent premature ageing and leaks. The doors will be easier to open as well, if they are kept pliable, the door seals will be less likely to freeze up in the winter. ■

Wheels

The wheels require regular attention to preserve their appearance. It is important to remove road salt and brake dust by washing the wheels at regular intervals, otherwise the finish will be impaired.

After washing, the wheels should only be cleaned with an "acid-free" cleaning agent for alloy wheels. This is available from Audi R8 dealers and specialist retailers. Never leave the cleaning agent on the rims for any longer than specified in the instructions before rinsing it off. If the wheel cleaner fluid contains acid it can attack the surfaces of the wheel bolts.

Car polish or other abrasive agents should not be used. If the protective paint coating is damaged by stone chips etc., the damaged area should be touched up immediately.



Please note when cleaning the wheels that water, ice and road salt can impair the effectiveness of the brakes – this can cause an accident. ■

Care of interior

Plastic parts and leatherette

Plastic parts and leatherette can be cleaned with a damp cloth. If this is not sufficient, plastic parts and leatherette should only be treated with a **special solvent-free plastic cleaner**. ■

Applies to vehicles: with carbon parts

Carbon parts

The carbon parts on your vehicle have a painted surface. They do not need any special care and are cleaned just like plastic parts ⇒ *page 147*. ■

Textile covers and trim parts

Textile covers and trim parts (e.g. seats, door trim) should be cleaned regularly with a vacuum cleaner. This will remove surface dirt which could otherwise be rubbed into the textile material during use. Do not use steam cleaners, as the steam could carry the dirt deeper into the textile material.

Normal cleaning

We recommend that you use a soft sponge or lint-free, micro-fibre cloth for normal cleaning. Only use brushes on floor coverings and mats, as other textile surfaces could become damaged. ▲

In the case of normal surface dirt you can use a foam cleaner. Use a sponge to spread the foam on the textile surface and to work it into the material lightly. However, make sure that the textile material does not become soaking wet. Then dab off the foam with a dry and absorbent cloth (e.g. a micro-fibre cloth) and vacuum off any residue once the surface is completely dry.

Removal of stains

To treat stains caused by spilled drinks (coffee, fruit, juice or similar) make up a solution with a mild detergent for sensitive fabrics and apply it with a sponge. If the stains are difficult to remove, a washing paste can be applied directly onto the stain and worked into the fabric. The surface will then have to be wiped with clear water to remove any residue left by the paste. To do so, use a damp cloth or sponge and then dab the stain with an absorbent cloth.

Treat chocolate or make-up stains with a washing paste and then rinse off with water (using a damp sponge).

A spirit-based cleaner can be used to remove grease, oil, lipstick or ball point pen. Then dab the dissolved grease or colour particles off with an absorbent cloth or similar. You may also have to treat the stain once more using washing paste and water.

If the covers or textile trim panels are badly soiled we recommend that you have them cleaned by a professional cleaning company.



Note

Please make sure you close any velcro fasteners on your clothing, as these could otherwise damage the upholstery. ■

Applies to vehicles; with leather upholstery

Natural leather

Audi does everything possible to preserve the special qualities of leather as a natural product.

General notes

We have a wide selection of leathers. The main type used is nappa in various forms, that is leather with a smooth surface in a selection of colours.

The amount of dye used determines the appearance and properties of leather. If the leather is left in a more natural state, it retains its typical natural appearance and is pleasant and comfortable for the seat occupants. Fine veins, healed scars, insect bites, wrinkles and a subtle variation in shading remain visible; these are the characteristic features of genuine natural leather.

Natural napped leather does not have a protective surface coating of dye. It is therefore somewhat more prone to damage. You should bear this in mind if children or pets often travel in the car, or if there are other factors that could lead to damage.

Types of leather with a coloured surface coating are likely to be more resistant to damage. This has a great advantage for day-to-day use. However, this means that the typical natural characteristics of the surface are less apparent, though this does not affect quality.

Cleaning and care

Because of the natural properties of the specially selected hides employed, the finished leather has a certain sensitivity to grease and dirt, etc. so a degree of care is required in everyday use and when looking after the leather. Dark clothing (especially if damp or incorrectly dyed) may stain leather upholstery. Dust and grit in the pores and seams can have an abrasive effect and damage the surface of the leather. Therefore leather should be cleaned at regular intervals, depending on the actual amount of use. When they have been in use for a certain time, your car seats will acquire

a typical and distinctive patina. This is characteristic for real leather upholstery, and is a sign of genuine quality.

To maintain the value of natural leather you should note the following points:

⚠ Caution

- Avoid exposing leather to direct sunlight for long periods, otherwise it may tend to lose some of its colour. If the car is left for a prolonged period in the bright sun, it is best to cover the leather.
- Sharp-edged objects on clothing, such as belts, zip fasteners, rivets or similar, can also leave permanent scratches and rough marks on the surface of the leather.

ℹ Note

- Use a suitable impregnating cream with ultra-violet protection at regular intervals and after cleaning. This cream will nourish and moisturise the leather, keep it supple and able to breathe. In addition, it will also help to protect the surface of the leather.
- Clean the leather every 2 to 3 months and remove fresh dirt as necessary.
- Remove stains from fresh ball-pen and other inks, lipstick, shoe cream and similar stains as soon as possible.
- Preserve the colour of the leather. A special coloured cream will renew the colour of the leather when required and will eliminate differences in colour. ■

Applies to vehicles: with leather upholstery

Cleaning and care of leather upholstery

Natural leather requires an extra degree of attention and care.

Normal cleaning

- Moisten a cotton or woollen cloth with water and wipe over the leather surfaces.

More stubborn dirt

- More stubborn dirt can be removed using a mild soap solution (pure liquid soap: two tablespoons dissolved in one litre of water).
- It is very important not to let the water soak through the leather or penetrate into the seams.
- Then wipe off with a soft, dry cloth.

Removal of stains

- Remove fresh **water-based** stains such as coffee, tea, juices, blood etc. with an absorbent cloth or kitchen roll, dried-on stains with the cleaning agent from the care set.
- Remove fresh **fat-based** stains on the surface such as butter, mayonnaise, chocolate, etc. with an absorbent cloth or kitchen roll or with the cleaning agent from the care set.
- Treat **fat-based, dried-in** stains with grease-dissolving spray.
- Treat **less common stains** such as ball-pen and other inks, felt-tip pens, nail polish, dispersion paint, shoe cream etc. with a special leather stain remover. ▲

Controls

Safety

Driving tips

General maintenance

Self-help

Technical data

Care of vehicle and cleaning

Leather care products

- The leather should be treated regularly (about twice a year) with a special leather-care product.
- Apply the cream very sparingly.
- Then wipe off with a soft, dry cloth.

Should you have any questions regarding the care and cleaning of the leather upholstery in your vehicle, we recommend that you contact your Audi R8 dealer. The staff there will gladly provide you with further information on cleaning and care of your upholstery and on our complete range of leather care products:

- Cleaning and care set
- Coloured leather-care cream
- Stain remover for ball-pen inks, shoe cream etc.
- Grease dissolving spray
- New products and further developments



Caution

On no account use solvents (such as petrol, turpentine), wax polish, shoe cream or similar materials. ■

Applies to vehicles with Alcantara seat covers

Cleaning Alcantara

Removing dust and dirt

- Moisten a cloth *just a little* and wipe down the seat covers.

Removing stains

- Moisten a cloth with lukewarm water or diluted **methylated spirits**.

- Dab at the stain. Start at the outside and work inwards.
- Dry the area you have cleaned with a soft cloth.

Do not use leather cleaning products on Alcantara seat covers.

You may use a suitable shampoo on dust and dirt.

Dust and grit in the pores and seams can have an abrasive effect and damage the surface of the leather. If the car is left standing in the sun for long periods, the leather should be protected against direct sunlight to prevent it from fading. However, slight colour variations will arise in normal use.



Caution

- Do not use solvents, wax polish, shoe cream, stain removers, leather cleaning products or any similar products on Alcantara.
- To avoid damage, stubborn stains should be removed by a qualified workshop.
- On no account use brushes, hard sponges or similar utensils. ■

Seat belts

- Keep the seat belts clean.
- For cleaning, use a mild soap solution.
- Check the condition of the seat belts at regular intervals.

Very dirty belts may not retract properly. Make sure that the inertia reel seat belts are completely dry before allowing them to retract.



Caution

- Do not remove the seat belts from the vehicle to clean them. ▲

- Do not use chemical cleaning agents on the seat belts, as this can damage the webbing. Ensure that the belts do not come into contact with corrosive fluids.
- If you find any damage to the belt webbing, belt fittings, the belt retractor or the buckle, the belt in question must be replaced by a qualified workshop. ■

Fuel and filling the tank

Fuel and filling the tank

Petrol

Petrol grade

The correct grade of petrol is listed inside the fuel tank flap.

The vehicle is equipped with a catalytic converter and must only be run on **unleaded petrol**. Unleaded petrol must comply with the European EN 228 standard. The petrol grades have different **octane ratings** (RON). If, in exceptional circumstances, the correct octane rating is not available, please note the following:

Your engine normally requires **Super Plus unleaded petrol (98 RON)**. Premium unleaded fuel with 95 RON can also be used. This can, however, result in a slight loss of power under certain driving conditions. If premium unleaded petrol is not available, the engine can be run on regular unleaded petrol with 91 RON as an *emergency measure*. In this case only use moderate engine speeds and a light throttle. Avoid using full throttle. Fill up with premium or Super Plus petrol as soon as possible.



Caution

- Petrol complying with the EN 228 standard can contain small quantities of ethanol. However, "bioethanol fuels", which are retailed under various different names such as E50 and E85, and which contain a large proportion of ethanol, must **not** be put into the vehicle, as this would damage the fuel system.
- Even one tankful of leaded fuel would permanently impair the efficiency of the catalytic converter.
- High engine speed and full throttle can damage the engine when using petrol with an octane rating lower than the correct grade for the engine. ■

Filling the tank

Filling the tank



Fig. 112 Tank flap release button in the driver's door trim



Fig. 113 Fuel tank flap with tank cap attached

Unscrewing the tank cap

- Press the top button to open the fuel tank flap.
- Unscrew the tank cap anti-clockwise.
- Hook the cap onto the open flap ⇒ fig. 113. ▲

Closing the tank cap

- Screw on the tank cap clockwise until it clicks audibly.
- Close the tank flap.

When the automatic filler nozzle is operated correctly it will switch itself off as soon as the tank is "full". Do not try to put in more fuel after the nozzle cuts out, as this will fill the expansion chamber in the fuel tank.

The correct fuel grade for your vehicle is given on a sticker on the inside of the tank flap. Further notes on fuel ⇒ *page 152*.

The tank capacity of your vehicle is given in the **Technical data** section ⇒ *page 198*.

WARNING

Fuel is highly inflammable and can cause serious burns and other injuries.

- When filling your tank or a spare fuel canister with fuel, do not smoke and keep away from naked flames. Risk of explosion!
- Observe all relevant statutory regulations on using, storing and transporting spare fuel canisters.
- For safety reasons we do not recommend carrying a spare fuel canister in the vehicle. The canister could become damaged in an accident and leak.
- If, in exceptional circumstances, you have to carry a spare fuel canister, please observe the following warnings:
 - Never fill fuel into the spare fuel canister with the canister placed in or on top of the vehicle. An electrostatic charge could build up during filling, causing the fuel vapour to ignite. Danger of explosion. Always place the canister on the ground to fill it.
 - Insert the filler nozzle as far as possible into the spare fuel canister.

WARNING (continued)

- If the spare fuel canister is made of metal, the filler nozzle must be in contact with the canister during filling. This helps prevent an electrostatic charge building up.
- Make sure you never spill fuel in the vehicle or in the luggage compartment. Fuel vapour is explosive. Risk of fatal accident!

Caution

- If any fuel is spilt onto the vehicle, it should be removed immediately as it could otherwise damage the paintwork.
- Never run the tank completely dry. If there is an irregular fuel supply, misfiring can occur. As a result unburnt fuel can enter the exhaust system and cause damage to the catalytic converter(s).



For the sake of the environment

Do not overfill the fuel tank – it may cause the fuel to overflow if it becomes warm.



Note

- Should the fuel tank flap become frozen stuck during inclement weather, press the middle of the flap with the palm of the hand and try again.
- When the fuel filler pump switches itself off, wait 5 seconds before pulling out the fuel nozzle so that any remaining fuel flows into the tank opening. ■

154 Fuel and filling the tank

Releasing the tank flap manually

The tank flap can be released manually if the tank unlocking system should fail to operate.



Fig. 114 Engine compartment: Manual release

- Open the engine lid.
- Pull the plastic cord firmly to the left until the tank flap springs open. ■

Checking and topping up fluids

Engine lid

Opening the engine lid

The engine lid is released from inside the vehicle.



Fig. 115 Detail of footwell on driver's side:
Release lever

- Open the driver's door.
- Make sure that the rear spoiler is retracted ⇒ [page 134](#).
- To release the engine lid, pull the lever under the dashboard ⇒ [fig. 115](#).
- Open the engine lid ⇒

The engine lid is held open by two gas-filled struts.

WARNING

To avoid the risk of being scalded, never open the engine lid if you see steam or coolant escaping from the engine compartment. Wait until no steam or coolant can be seen before opening the engine lid. ■

Working on components in the engine compartment

Extra caution is necessary when working on components in the engine compartment.

Always be aware of the danger of injury and scalding as well as the risk of accident or fire when working in the engine compartment (e.g. when checking and refilling fluids). Always observe the warnings listed below and follow all normal safety precautions. The engine compartment of any motor vehicle is a potentially hazardous area ⇒

WARNING

- Switch off the engine.
- Apply the handbrake firmly.
- Put the gear lever in neutral or the R tronic selector lever in N.
- Remove the ignition key.
- Wait for the engine to cool down.
- Keep children away from engine compartment.
- Never spill fluids on hot engine components. These fluids can cause a fire (e.g. radiator anti-freeze).
- Take care not to cause short circuits in the electrical system, especially when working on the battery.
- Do not unscrew the cap on the expansion tank when the engine is hot. The cooling system is under pressure.
- Protect face, hands and arms by covering the cap with a large, thick rag to protect against escaping coolant and steam.
- If any tests have to be performed with the engine running, there is an extra safety risk from the rotating parts, such as the

Checking and topping up fluids

⚠ WARNING (continued)
drive belts and alternator, etc., and from the high-voltage ignition system.

- Observe the following additional warnings if work on the fuel system or the electrical system is necessary:
 - Always disconnect the battery
 - Do not smoke
 - Never work near open flames
 - Always keep an approved fire extinguisher immediately available.

⚠ Caution

When topping up fluids make sure the correct fluid is put into the correct filler opening. This can otherwise cause serious malfunctions or engine damage.

🌿 For the sake of the environment

Inspect the ground underneath your vehicle regularly so that any leaks are detected at an early stage. If you find oil spots or other fluids, have your vehicle inspected by a qualified workshop.

ℹ Note

On right-hand drive vehicles* some of the containers/ reservoirs mentioned below are located on the other side of the engine compartment. ■

Closing the engine lid

- Make sure that the rear spoiler is retracted ⇒ *page 134*.
- To close the engine lid, pull it down to overcome the spring pressure.

- Then let it drop into the catches; *do not press down* ⇒ **⚠**.

⚠ WARNING

For safety reasons the engine lid must always be completely closed when the vehicle is moving. After closing it always check that it is properly secured. The engine lid must be flush with the adjacent body panels. ■

Engine compartment layout

Main components for checking and refilling



Fig. 116 Typical locations of fluid containers, engine oil dipstick and engine oil filler cap

① Hydraulic fluid reservoir for power steering	136
② Engine oil filler cap (🔑)	158
③ Engine oil dipstick	157
④ Radiator expansion tank (⬆)	160 ■

Engine oil

General notes

We recommend that you have the oil change carried out by an Audi R8 dealership or qualified workshop according to the intervals stated in the Service Schedule or according to the service interval display in the instrument cluster.

Whether your vehicle is serviced at *flexible* service intervals or *fixed* service intervals is shown in the Service Schedule.

The correct oil specifications for your engine are listed in the **Technical data** section ⇒ *page 198*, "Performance, weights and dimensions".

Check that the specifications quoted (VW standards) appear on the container either singly or in combination with other specifications.

Flexible service intervals (LongLife Service*)

Special engine oils ⇒ *page 198*, "Performance, weights and dimensions" have been developed as part of the Audi LongLife Service (⇒ "Service Schedule").

This type of oil **must** be used if you intend to take advantage of the extended maintenance intervals allowed by Audi's LongLife Service.

- Do not mix the LongLife oil with oil intended for fixed service intervals, as the requirements for the extended service intervals are then no longer guaranteed.
- In exceptional circumstances, if the engine oil level is too low ⇒ *page 157* and you cannot obtain the specified LongLife oil, you can put in a small quantity of oil for **fixed service intervals** - ⇒ *page 198*, "Performance, weights and dimensions". This should not be done more than once and no more than 0.5 litres should be used.

Fixed service intervals (Inspection Service*)

If you do not take advantage of the LongLife service for your car, you can use the oils for **fixed service intervals** - ⇒ *page 198*, "Performance, weights and dimensions". In this case, your car must be serviced after a fixed interval of 1 year / 15,000 km (10,000 miles) - see Service Schedule.

- In exceptional circumstances, if the engine oil level is too low ⇒ *page 157* and you cannot obtain the oil specified for your vehicle, you can put in a small quantity of oil conforming to the specification ACEA A2 or ACEA A3. This should not be done more than once and no more than 0.5 litres should be used. ■

Checking the oil level



Fig. 117 Instrument cluster: Engine oil temperature display

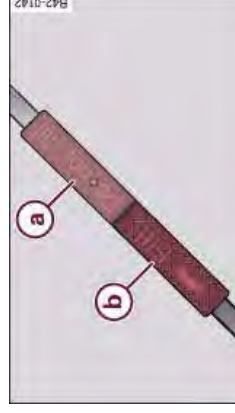

Fig. 118 Markings on oil dipstick

Checking and topping up fluids

Checking oil level

- Warm up the engine by driving the vehicle until the oil temperature shown in the instrument cluster is between 100 °C and 110 °C ⇒ *page 157*, fig. 117.
- Park your vehicle on a level surface.
- Allow the warm engine to run for about two minutes at idling speed.
- Switch off the engine and wait for two minutes.
- Check the oil level using the dipstick ⇒ *page 157*, fig. 118.

Oil level in area **a**

- Do *not* top up oil.

Oil level in area **b**

- Add 1 litre of oil ⇒ *page 158*. After topping up the oil level should be in area **a**.

Depending on how you drive and the conditions in which the car is used, oil consumption can be up to 1.0 ltr./1000 km. Oil consumption is likely to be higher for the first 5000 km. ■

Topping up the engine oil



Fig. 119 Engine compartment: Engine oil filler cap

- Unscrew cap from oil filler opening ⇒ fig. 119.
- Top up carefully using the correct oil ⇒ *page 198*.
- Check the oil level again ⇒ *page 157*.
- Top up with oil if necessary.
- Replace the oil filler cap carefully and push the dipstick all the way in.

WARNING

- Ensure that no oil comes into contact with hot engine components when topping up: this could cause a fire.
- Wash your skin thoroughly if it comes into contact with engine oil.

Caution

- The oil level must never be above area **a**, as this may result in damage to the catalytic converter or to the engine. Contact a qualified workshop to extract the engine oil if necessary. ▲

- No additives should be used with engine oil. Any damage caused by the use of such additives would not be covered by the factory warranty.

For the sake of the environment

- Never pour oil down drains or into the ground.
- Always observe statutory requirements when disposing of empty oil canisters. ■

Cooling system

Coolant

The purpose of the coolant is to carry heat away from the engine. The correct amount of anti-freeze is important to prevent the cooling system from freezing in winter.

The cooling system is filled for life at the factory, so the coolant does not need to be changed. The coolant consists of a mixture of water and anti-freeze additive G12++. This is a glycol-based anti-freeze with anti-corrosion additives.

Anti-freeze additive

The amount of anti-freeze additive required depends on the temperatures to be expected in the winter season. If the anti-freeze concentration is too low the coolant can freeze, resulting in failure of the cooling system and heater.

The cooling system is filled at the factory with the correct amount of anti-freeze for the country concerned.

In most cases the mixture consists of **60% water and 40% additive**. This mixture gives the required anti-freeze protection at temperatures down to -25°C and protects the alloy parts of the cooling system against corrosion. It also prevents scaling and raises the boiling point of the coolant.

Countries with warm climate

The coolant concentration must not be reduced by adding plain water, even in the summer or in warm climates. The concentration of the anti-freeze additive must always be **at least 40%**.

Countries with cold climate

If greater anti-freeze protection is required in very cold climates, the proportion of the anti-freeze additive G12++ can be increased. A concentration of 60% offers protection down to about -40°C . The concentration of the anti-freeze additive must **not be more than 60%**, otherwise this would reduce the anti-freeze protection. In addition, the cooling effect will be adversely affected.

Vehicles for export to countries with a cold climate (such as Sweden, Norway and Finland) are supplied with antifreeze protection down to about -35°C . The concentration of the antifreeze additive for these countries should always be at least 50%.

Caution

- It is advisable to have the cooling system checked before the winter season to make sure that the anti-freeze concentration is adequate for the conditions to be expected. This applies particularly if you intend to take the car into a colder climate zone. If necessary, have the anti-freeze concentration increased to 50 - 60% as required.
- Use only antifreeze additive G12++, an additive meeting the specification "TL-VW 774G". Other additives may give considerably inferior corrosion protection. The resulting corrosion in the cooling system can lead to a loss of coolant, causing serious damage to the engine.
- The coolant additive G12++ must not be mixed with any other additives. ■

Checking and topping up fluids

Checking coolant level

Be careful when checking the coolant.



Fig. 120 Engine compartment: Markings on radiator expansion tank

- Switch off the ignition.
- Cover the cap on the expansion tank with a cloth, and **carefully** unscrew the cap anti-clockwise ⇒ .
- Read off the coolant level on the inside of the radiator expansion tank ⇒ fig. 120. When the engine is cold it must be above the "min" mark. When the engine is hot it may be slightly above the marked area.

The expansion tank is located in the engine compartment on the right. Its location is also shown in the illustration of the engine compartment ⇒ *page 156*.

The coolant level should be checked with the engine switched off.

The coolant level is monitored by a warning lamp in the instrument cluster ⇒ *page 35*. However, we recommend that it should be checked occasionally.

Coolant losses

Any loss of coolant normally indicates a **leak** in the cooling system. In this case the cooling system should be inspected by a qualified

workshop without delay. It is not sufficient merely to top up the coolant.

If there are **no leaks** in the system, a loss of coolant can only occur if the coolant boils and is forced out of the system as a result of overheating.

WARNING

- The cooling system is under pressure. Do not unscrew the cap on the expansion tank when the engine is hot: you could be scalded by escaping steam
- The coolant and coolant additive can be a health hazard. Store the coolant additive in the original container in a safe place out of reach of children – risk of poisoning.

Caution

Radiator sealants must not be added to the coolant. Such additives could seriously impair the function of the cooling system. ■

Topping up the coolant

- Add coolant.
- Turn the cap clockwise until it engages.

Make sure that the coolant meets the required specifications ⇒ *page 159*, "Coolant". Do not use a different type of additive if anti-freeze additive G12++ is not available. In this case use only water and bring the coolant concentration back up to the correct level as soon as possible by putting in the specified additive.

Always top up with *fresh, unused* coolant.

Fill up only to the top edge of the marked area. Excess coolant is forced out of the system through the valve in the filler cap when the engine gets hot. ▲

If a lot of coolant has been lost, wait for the engine to *cool down* before putting in cold coolant. Failure to do so could result in serious engine damage.



WARNING

The coolant and coolant additive can be a health hazard. Store the coolant additive in the original container in a safe place out of reach of children – risk of poisoning.



For the sake of the environment

Drained off coolant should not be used again. Drain off the used coolant into a suitable container and dispose of it in the proper manner (observe environmental regulations). ■

Radiator fan

The radiator fan can start running spontaneously.

The radiator fan is powered electrically. The speed of the fan is varied according to the temperature registered by a thermostat.

- The radiator fan or auxiliary fan can continue to run for as long as 10 minutes after stopping the engine – even after the ignition is switched off. It may also start running suddenly after a while if
- residual heat raises the coolant temperature, or
 - the hot engine compartment is additionally heated up by the sun. ■

Brake fluid

Note

When required, the brake fluid should be changed by a competent mechanic with the proper equipment.

Brake fluid gradually absorbs moisture from the atmosphere. If the water content in the brake fluid is too high, this may cause corrosion in the brake system over time. In addition, the boiling point of the brake fluid will be considerably reduced. This could adversely affect the braking ability in certain circumstances.

For this reason the brake fluid must be changed periodically.

Your vehicle's Service Schedule will tell you when the brake fluid has to be changed.

The brake fluid is replaced by your Audi R8 dealer as part of the Inspection Service. They are familiar with the procedure and have the necessary special tools and spare parts as well as the proper facilities for disposing of the old fluid.

Use only the genuine brake fluid specified by the factory. Qualified workshops know that the brake fluid "DOT 4" is approved by Audi. The brake fluid must be fresh and unused.



WARNING

Heavy use of the brakes may cause a vapour lock if the brake fluid is left in the system for too long. This would seriously affect the efficiency of the brakes and the safety of the car – risk of accident. ■

Checking and topping up fluids

Battery

General notes

All work on batteries requires specialist knowledge.

The battery is located behind the cover in the luggage compartment. To remove the cover, slide it to the left and lift it out.

The battery is virtually maintenance-free and is checked in the Inspection Services.

We recommend that you replace a battery once it is older than 5 years.

Disconnecting the battery

If the battery is disconnected, some of the vehicle's functions will become inoperative (e.g. electric windows). These functions will require resetting after the battery is reconnected. For this reason, the battery should only be disconnected from the vehicle's electrical system when absolutely necessary.

If the vehicle is not used for long periods

The battery will gradually lose its charge because certain electrical equipment continues to draw current even when the ignition is off. If you park the vehicle for long periods of time in **winter** you should have your Audi R8 dealer take the battery out of the vehicle and keep it in a frost-proof room. This ensures that it cannot "freeze up" and be damaged. At **warm** outside temperatures it is sufficient to disconnect the negative terminal of the battery. Even when the battery is not connected you should charge it from time to time.

Winter conditions

The battery is drained more in cold weather, which means that the starting power is reduced. For this reason, have the battery checked and charged if necessary before the start of winter.

Replacing the battery

A replacement battery **must** have the same capacity, voltage and current rating. It must also have the same dimensions as the original, factory-fitted battery and have sealed caps. The Audi batteries which have been specially developed fulfil the maintenance, performance and safety specifications for your vehicle.

We recommend to use only maintenance-free batteries or **deep-cycle resistant and leakproof** batteries which comply with the standards TL 825 06 (dated December 1997 or later) and VW 7 50 73 (August 2001 or later).

Since the battery is difficult to access, we recommend having it replaced by an Audi R8 dealer or qualified workshop.

WARNING

- **All work on batteries requires specialist knowledge. For queries regarding the vehicle battery please contact an Audi R8 dealership or other qualified workshop (risk of chemical burns / risk of explosion).**
- **The battery must not be opened. Do not attempt to make any changes to the electrolyte level of the battery. Otherwise, there is a risk that a mixture of oxygen and hydrogen gas can accumulate and cause an explosion.**

Caution

- The battery holder and clamps must always be correctly secured.
- Before starting any work on the battery, always observe the **warnings** listed under  in "Important safety warnings for handling a car battery" on *page 163*.







For the sake of the environment

- ✘ Batteries contain toxic substances including sulphuric acid and lead. They must be disposed of appropriately and must not be put together with ordinary household waste. Make sure the battery 

removed from the vehicle cannot tip over. Otherwise, sulphuric acid could escape. ■

Important safety warnings for handling a car battery

	Wear safety glasses!
	Battery acid is extremely corrosive. Wear protective gloves and safety glasses.
	Keep open flames, sparks, uncovered lights and lit cigarettes away from battery!
	A highly explosive mixture of gases is given off when the battery is under charge!
	Keep children away from the battery and battery acid.

WARNING
Always be aware of the danger of injury and chemical burns as well as the risk of accident or fire when working on the battery and the electrical system.

- Switch off all electrical equipment and remove the ignition key before starting any work on the vehicle electrical system. The minus cable of the battery must be disconnected. When changing a light bulb, it is sufficient to only turn off the light.
- Keep children away from the battery and battery acid.
- Battery acid is extremely corrosive. Wear protective gloves and safety glasses. Do not tilt the battery - acid can leak out of the vapour vent. Do not allow acid or lead particles to come into contact with eyes, skin or clothing. If electrolyte should splash into the eyes rinse at once for several minutes using clear water. Then seek medical care immediately. Neutralize any acid splashes

WARNING (continued)
on the skin or clothing with soap solution, and rinse off with plenty of water. If acid is swallowed by mistake, consult a doctor immediately.

- Keep open flames, sparks, uncovered lights and lit cigarettes away from battery. Avoid sparks (including those from static charges) when handling cables and electrical equipment. Never cross the battery poles. The resulting high-energy sparks can cause injury.
- A highly explosive mixture of gases is given off when the battery is under charge. Only charge battery in a well ventilated area.
- When disconnecting the battery from the vehicle's electrical system, first disconnect the minus cable and then the plus cable.
- Before reconnecting the battery, turn off all electrical equipment. First connect the plus cable, then the minus cable. The battery cables must not be connected to the wrong battery poles - serious risk of cable fire.
- Never charge a frozen or thawed out battery - risk of explosion and chemical burns! A battery must be replaced once it has been frozen. When it is discharged the battery can freeze at temperatures around 0°C.
- Never use a damaged battery - risk of explosion! Replace the damaged battery immediately.



Caution

- Never disconnect the car's battery with the engine running or with the ignition turned on, otherwise the electrical system or electrical components will be damaged.
- Do not expose the battery to direct sunlight over a long period of time, as the intense ultraviolet radiation can affect the battery housing. ■

Checking and topping up fluids

Charging the battery

A fully-charged battery is important for reliable starting.

- Note the warnings ⇒  in "Important safety warnings for handling a car battery" on page 163 and ⇒ .
- Switch off the ignition and all electrical equipment.
- Only if "fast-charging": both battery cables must be disconnected (first the "negative" cable, then the "positive" cable).
- Connect the charger cables to the battery terminals, noting the colour code (red is used for "positive", black or brown for "negative").
- Now connect the battery charger to the mains and switch on.
- After charging the battery: switch off the battery charger and disconnect the mains cable.
- Now disconnect the charger cables.
- If necessary, reconnect both battery cables to the battery (first the "positive" cable, then the "negative" cable).

When charging with a low current (for example with a **small battery charger**) the battery cables do not normally have to be disconnected. However, both battery cables must be disconnected before "**fast-charging**" the battery with a *high* current. However, always follow the instructions given by the manufacturer of the battery charger.

*Fast-charging a battery is **dangerous** ⇒  in "Important safety warnings for handling a car battery" on page 163. This work should only be performed by a competent mechanic with the proper equipment. If necessary, we therefore recommend that this work should only be performed by a qualified workshop.*

When it is discharged the battery can **freeze** at temperatures around 0°C. A frozen battery must be thawed before charging ⇒ . However, it is advisable to replace the battery if it has frozen, because the ice can crack the battery casing and allow the battery acid to escape.

The battery caps should not be opened while the battery is being charged.

WARNING

Never charge a frozen battery – it could explode. ■

Windscreen washer

Plain water on its own is not sufficient for the windscreen washer system.



Fig. 121 Luggage compartment: Windscreen washer container

The container for the windscreen washer  is located in the luggage compartment and contains the cleaning fluid for the windscreen and the headlight washer system ⇒ fig. 121. Container capacity: ⇒ page 199.

Plain water on its own is not enough to clean the glass properly. It is therefore advisable to add a suitable washer fluid additive (with

wax solvent) to the water. A washer fluid with freeze-resistant additive should be used in winter.

 **Caution**

- Never put in radiator anti-freeze or other additives.
- Never use washer fluid which contains paint thinners or solvents as it can damage the paintwork. ■

Wheels and tyres

Wheels

General notes

- When driving with **new tyres**, be especially careful during the first 500 km.
- If you have to drive over a kerb or similar obstacle, drive very slowly and as near as possible at a right angle to the kerb.
- Inspect the tyres regularly for damage (cuts, cracks or blisters, etc.). Remove any foreign bodies embedded in the treads.
- Damaged wheels and tyres must be replaced immediately.
- Keep grease, oil and fuel off the tyres.
- Replace any missing valve caps as soon as possible.
- Mark the wheels before taking them off so that they rotate in the same direction when put back.
- When removed, the wheels or tyres should be stored in a cool, dry and preferably dark place.

New tyres

New tyres do not give maximum **grip** straight away and should therefore be "run in" by driving carefully and at moderate speeds for about the first 500 km. This will also help to make the tyres last longer.

The **tread depth** of new tyres may vary, according to the type and make of tyre and the tread pattern.

Concealed damage

Damage to tyres and rims is often not readily visible. If you notice unusual **vibration** or the car **pulling to one side**, this may indicate that one of the tyres is damaged. Reduce speed immediately if there is any reason to suspect that damage may have occurred. Inspect the tyres for damage. If no external damage is visible, drive slowly and carefully to the nearest qualified workshop and have the car inspected.

Tyres with directional tread pattern

An arrow on the tyre sidewall indicates the direction of rotation on tyres with directional tread. Always note the direction of rotation indicated when mounting the wheel. This guarantees optimum grip and helps to avoid aquaplaning, excessive noise and wear.

Wheels with bolted rim flange*

Light-alloy wheels with a bolted rim flange consist of several components. A special technique is applied to bolt these components together. Apart from safety and true running this also ensures that the wheel functions correctly and that there is no leakage. Damaged rims must therefore be replaced; you must never attempt to repair or dismantle them ⇒ ⚠.

Wheels with bolted trim parts*

Light-alloy wheels can be fitted with interchangeable trim parts which are attached to the rim using self-locking bolts. Should you wish to replace damaged trim parts please contact a qualified workshop.



WARNING
Never remove the bolts on a wheel with bolted rim flange* (accident risk). ■

Tyre service life

Correct inflation pressures and sensible driving habits will increase the service life of your tyres.

- Check the tyre pressures at least once a month.
- The tyre pressures should only be checked when the tyres are *cold*. The slightly raised pressures of warm tyres must not be reduced.
- The pressures must be altered to suit major changes in the load being carried.
- Avoid fast cornering and hard acceleration.
- Inspect the tyres for irregular wear from time to time.

The service life of your tyres depends on the following factors:

Tyre pressure

Under-inflation or over-inflation will reduce the life of the tyres considerably and also impair the car's handling. The inflation pressures are listed on a sticker on the driver's door pillar.

Correct inflation pressures are very important, especially at **high speeds**. The pressures should therefore be checked at least once a month and before starting a journey.

Driving habits

Fast cornering, heavy acceleration and hard braking (squealing tyres) all increase tyre wear.

Wheel balancing

The wheels on new vehicles are balanced. However, various factors encountered in normal driving can cause them to become unbalanced, which results in steering vibration.

Unbalanced wheels should be rebalanced, as they otherwise cause excessive wear on steering, suspension and tyres. A wheel must also be rebalanced when a new tyre is fitted or if a tyre is repaired.

Incorrect wheel alignment

Incorrect wheel alignment causes excessive tyre wear, impairing the safety of the vehicle. If you notice excessive tyre wear, contact your Audi R8 dealer.



WARNING

- Always adapt the tyre pressure accordingly when the vehicle load changes.
- Under-inflated tyres flex more and can overheat at continuous high speeds. This can cause tread separation and tyre blow-out, which could result in an accident. Always observe the recommended tyre pressures.



For the sake of the environment

Under-inflated tyres will increase the fuel consumption. ■

Tread wear indicators

The tread wear indicators show the condition of the tyre treads.



Fig. 122 Tyre tread:
Tread wear indicators

The original tyres on your vehicle have 1.6 mm high "tread wear indicators" ⇒ fig. 122 running across the tread. Depending on the make, there will be 6 to 8 of them spaced at equal distances around the tyre. Markings on the tyre sidewall (for instance the letters "TWI" or a triangle) indicate the positions of the tread wear indicators.

The minimum tread depth required by law in Germany is 1.6 mm (measured in the tread grooves next to the tread wear indicators). Different figures may apply in other countries.

! WARNING

To avoid putting safety at risk, the tyres must be replaced at the latest when the tread is worn down to the tread wear indicators.

- Especially in difficult driving conditions such as wet or icy roads, it is important that the tyres have sufficient tread depth. The tread depth should be the same on the tyres of both the front and the rear axles.

- The decrease in driving safety due to insufficient tread depth is particularly evident in vehicle handling, when there is a risk of

! WARNING (continued)

aquaplaning in deep puddles of water and when driving through corners. Braking is also adversely affected.

- The speed has to be adapted accordingly, otherwise there is a risk of losing control over the vehicle. ■

Replacing wheels and tyres

It is important to use the correct wheels and tyres when replacement is necessary.

- All four wheels must be fitted with tyres of the same type and preferably the same tread pattern.
- If possible, tyres should be replaced at least in pairs and not individually (i.e. both front tyres or both rear tyres together).
- Never use tyres whose actual size exceeds the dimensions of the factory-approved makes of tyre.
- If you wish to fit the vehicle with non-standard rims or tyres, it is advisable to consult an Audi R8 dealer before purchasing them.

The tyres and wheel rims are an essential part of the vehicle's design. The tyres and rims approved by Audi are specially matched to the characteristics of the vehicle and make a major contribution to good roadholding and safe handling ⇒ **! WARNING**

The sizes of the rims and tyres approved for your vehicle are listed in the vehicle's documents (e.g. EC Certificate of Conformity or COC document²⁾). The vehicle documents vary depending on the country of residence.

²⁾ COC = Certificate of conformity

Understanding the tyre designations makes it easier to choose the correct tyres. For example, radial ply tyres have the following **tyre designations** marked on the sidewall:

235 / 35 R 18 91 Y

This contains the following information:

235	Tyre width in mm
35	Height/width ratio in %
R	Tyre construction: Radial
18	Rim diameter in inches
91	Load rating code
Y	Speed rating code letter

The **manufacturing date** is also indicated on the tyre sidewall (possibly only on the *inner* side of the wheel):

DOT ... 1010...

means, for example, that the tyre was produced in the 10th week of 2010.

Please note that with some types of tyres, the actual tyre size can differ from the nominal size marked on the tyre (for instance 235/35 R 18 91 Y), and there may be significant differences in the contours of the tyres, even though the tyres are marked with the same nominal size designation. When replacing the tyres, it is therefore important to make sure that the actual size of the new tyres does not exceed the dimensions of the factory-approved makes of tyre. Failure to observe this requirement can affect the clearance needed for the tyres. This could result in contact between the tyres and suspension components or bodywork. The brake lines could also be damaged and the vehicle's safety could be severely impaired ⇒ ⚠. When using tyres with the maximum permitted nominal dimensions, this can also void the vehicle's registration.

If you use tyres that are approved by Audi you can be sure that the actual tyre dimensions will be correct for your vehicle. If you decide to fit a different type of tyre, you must obtain the appropriate manufacturer's certificate from the tyre retailer to confirm that the tyres are suitable for your vehicle. Keep this certificate in a safe place. Your local Audi R8 dealer will be able to advise you on which tyres may be fitted to your vehicle.

On vehicles with **four-wheel drive**, all four tyres must always be fitted with tyres of the same type, make and tread pattern, as otherwise the driveline can be damaged by continuous variations in the wheel speeds. For the same reason, only use a spare wheel with the same tyre dimensions as the normal road wheels.

It is not permissible to use a **wheel** which is of a type different to those already fitted on the vehicle (for instance when using winter tyres) - even if you have a puncture.

It is best to have all servicing of wheels and tyres performed by a **qualified workshop**. They have the necessary special tools and replacement parts, trained personnel and facilities for disposing of the old tyres.

⚠ WARNING

- It is very important to ensure that the tyres you have chosen have adequate clearance. When selecting replacement tyres, do not rely entirely on the nominal tyre size marked on the tyre; with some makes of tyre the effective tyre size can differ significantly from the nominal dimensions, even though the tyres have the same size designation. Inadequate tyre clearance can result in damage to the tyres or the vehicle, causing a serious safety risk. It may also invalidate the vehicle's type approval for use on public roads.
- Avoid running the car on tyres that are more than 6 years old. If you have no alternative, you should drive slowly and with extra care at all times.

WARNING (continued)

- If wheel trims are fitted after the car is purchased, ensure that there is an adequate flow of air for cooling the brakes.

**For the sake of the environment**

Old tyres must be disposed of according to the laws in the country concerned.

Note

- Tyres with the "R0" mark are specially matched to your Audi. We recommend that you use these tyres only. Your Audi R8 dealer or specialist retailer will gladly provide you with further information.
- Never mount used tyres if you are not sure of their previous history.
- For technical reasons it is not normally possible to use wheel rims from other vehicles. In some cases this also applies to rims from other vehicles of the same model. ■

Wheel bolts

The wheel bolts are designed to suit the rims on your car.

The **wheel bolts** are matched to the rims. When installing different wheels (for instance alloy wheels or wheels with winter tyres) it is important to use the correct wheel bolts with the right length and correctly shaped bolt heads. This is essential for the secure fit of the wheels and for the proper function of the brake system.

Audi R8 dealers have full information on the technical requirements when installing or changing tyres, rims or wheel trims.

The wheel bolts should be clean and turn easily.

A special adapter is required to turn the anti-theft wheel bolts*
⇒ *page 182.* ■

Winter tyres

Winter tyres will significantly improve the car's handling in winter road conditions.

- Use only **radial ply** winter tyres.
- Winter tyres must be fitted **on all four** wheels.
- Only use winter tyres of the correct type approved for your vehicle.
- Please note that the maximum permissible speed for winter tyres may be lower than for summer tyres.
- Also note that winter tyres are no longer effective when the **tread** is worn down.
- After fitting the wheels you must always check the tyre pressures. The correct tyre pressures are listed on the sticker on the driver's door pillar ⇒ *page 167.*

In winter road conditions winter tyres will considerably improve the car's handling. Due to their type of construction (width, rubber compound, tread pattern), summer tyres give less grip on ice and snow. This applies particularly to vehicles equipped with **wide section tyres** or **high speed tyres** (code letters H, V or Y on the side-wall).

Only use winter tyres of the correct type approved for your vehicle. The sizes of the winter tyres approved for your vehicle are listed in the vehicle's documents (e.g. EC Certificate of Conformity or COC document³⁾). The vehicle documents vary depending on the country of residence. Also refer to ⇒ *page 168.*

Winter tyres are no longer fully effective when the **tread** is worn down to a depth of 4 mm.

³⁾ COC = Certificate of conformity

The performance of winter tyres is also severely impaired by ageing, even if the tread is still much deeper than 4 mm.

Winter tyres are subject to the following **maximum speed limits** according to speed rating code letter: ⇒ 

Speed rating code letter ⇒ <i>page 168</i>	Maximum speed limit
Q	160 km/h
S	180 km/h
T	190 km/h
H	210 km/h
V	240 km/h (please note relevant restrictions)

In Germany vehicles capable of exceeding these speeds must have an appropriate **sticker** attached so it is visible to the driver. Suitable stickers are available from Audi R8 dealers and specialist retailers. Please note regulations to this effect in your country.

Using winter tyres with V-rating

Please note that the generally applicable 240 km/h speed rating for winter tyres with the letter "V" is subject to **technical restrictions; the maximum permissible speed for your vehicle may be significantly lower**. The maximum speed limit for tyres with a V-rating depends directly on the maximum axle weights for your car and on the listed weight rating of the tyres being used.

It is best to contact an Audi R8 dealer to check the maximum speed which is permissible for the V-rated tyres fitted on your car on the basis of this information.



WARNING
Exceeding the maximum speed permitted for the winter tyres fitted on your car can cause tyre failure, resulting in a loss of control of the vehicle – risk of accident.



For the sake of the environment

Summer tyres should be fitted again as soon as possible; they give better handling on roads which are free of snow and ice. Summer tyres produce less rolling noise, do not wear down as quickly and, most importantly, reduce fuel consumption. ■

Snow chains

Snow chains will improve the vehicle's handling on snow-covered roads.

- Snow chains can be used on the rear wheels only.
- Keep your speed below 50 km/h.

Snow chains will improve *braking ability* as well as *traction* in winter conditions.

For technical reasons snow chains may only be used on tyres with certain wheel rim/tyre combinations.

Rim size	Rim offset	Tyre size
8.5Jx18	42 mm	235/40
8.5Jx19	42 mm	235/35
10.5Jx18	55 mm	285/35
10.5Jx19	55 mm	295/30

Only use snow chains with **fine-pitch links**. The links must not protrude more than 13,5 mm from the tyres (including tensioner). ▲

Controls

Safety

Driving tips

General maintenance

Self-help

Technical data

Remove **wheel covers** (if fitted) and trim rings before attaching snow chains. For safety reasons cover caps must then be fitted over the wheel bolts. These are available from Audi R8 dealers.

Remove the chains when roads are *free of snow*. Otherwise they will impair handling, damage the tyres and wear out very quickly.

Four-wheel drive: Where snow chains are compulsory on certain roads, this normally also applies to cars with four-wheel drive. Snow chains may only be fitted to the *rear* wheels (also on vehicles with four-wheel drive). ■

Tyre pressure monitoring system

Applies to vehicles with tyre pressure monitoring system

Introduction

The tyre pressure monitoring system keeps a check on the inflation pressures of the four road wheels while you are driving.

The system warns the driver in the event of a loss of pressure by means of symbols and messages in the instrument cluster display. The system employs sensors on the wheels. The radio signals from these sensors are transmitted to the tyre pressure monitoring system.

Please bear in mind that the tyre inflation pressure is also influenced by the temperature of the tyre. For every 10°C increase in the tyre temperature the pressure will normally increase by about 0.1 bar. The tyre heats up while the vehicle is being driven and the tyre pressure will rise accordingly. For this reason, you should only adjust the tyre pressures when they are *cold* (i.e. approximately at ambient temperature).

To ensure that the tyre pressure monitoring system works reliably, you should check and, if necessary, adjust the tyre pressures at regular intervals.



The tyre pressures recommended for your vehicle are given on the sticker attached to the driver's door pillar.

Initialising the tyre pressure monitoring system

The inflation pressures for two sets of wheels (e.g. with winter and summer tyres) are stored on your vehicle. You can change between these two sets of wheels any number of times without re-initialising the system.

The tyre pressure monitoring system must be re-initialised by your Audi R8 dealer if a new set of wheels is used or the electronic sensors are renewed.

Warning lamp lit

If the tyre pressure is more than **0.5 bar** below the reference value, the display will show the tyre symbol  with a corresponding message, such as **Tyre pressures too low** .

WARNING

- If the warning lamp  lights up you must **slow down immediately and avoid any severe braking or steering manoeuvres**. As soon as you can do so safely, **stop and check the tyres and the tyre pressures**.
- **Never re-adjust the tyre inflation pressure when the tyre is hot**. This can cause serious damage to the tyre or even a **blow-out**, which could result in an accident.
- **Under-inflated tyres flex more and can overheat at continuous high speeds**. This can cause **tread separation and tyre blow-out**, which could result in an accident.



For the sake of the environment

Under-inflated tyres lead to increased fuel consumption and tyre wear.



Note

- Responsibility for ensuring that the tyres are correctly inflated remains with the driver; the system can only provide assistance.
- Only adjust the inflation pressure of the tyres when they are at approximately ambient temperature.
- The sensors and valves do not have to be detached or changed round when fitting new tyres. Only the valve core needs to be replaced, and if necessary the valve and the electronic components in the wheel.
- After using the Tyre Mobility System* the tyre pressure monitoring system may malfunction. The sensor for the tyre pressure monitoring system must therefore be renewed by a qualified workshop. ■

Applies to vehicles: with tyre pressure monitoring system

Malfunctions

If the tyre pressure monitoring system is inoperative, the tyre symbol or "TPMS" will appear on the display. This can have various causes:

- One of the wheel sensors or other related components may not be working.
- Snow chains can interfere with the signals emitted by the sensors so that the system cannot function properly.
- The tyre pressure monitoring system may be inoperative due to radio interference.
- Radio systems operating on the same frequency, such as radio headphones or two-way radios inside the vehicle, produce strong electromagnetic fields which can cause temporary interference.
- If the fault persists, take the vehicle to a qualified workshop. ■

Controls

Safety

Driving tips

General maintenance

Self-help

Technical data

Accessories and modifications to the vehicle

Accessories, replacement parts and repairs

It is best to consult an authorised Audi R8 dealer before purchasing accessories and replacement parts or having any repairs carried out.

Your car is designed to offer a high standard of active and passive safety. For this reason, we recommend that you ask an Audi R8 dealer for advice before fitting accessories or replacement parts. This is also very important if **body repairs** are required. Audi R8 dealers have full information on the manufacturer-approved repair methods and can recommend suitable accessories and spare parts. They can also give advice regarding official requirements for the vehicle.

We recommend you to use only **Audi accessories** and **Audi Genuine parts®**. Audi has tested these parts and accessories for suitability, reliability and safety. Audi R8 dealers have the necessary experience and facilities to ensure that the parts are installed properly.

Although the market is constantly scrutinised, Audi cannot judge or assume responsibility for the reliability, safety and suitability of non-genuine products - even though in some instances, these parts may have been approved by an officially recognised technical testing authority or accompanied by an official approval certificate.

Any **retro-fitted equipment** which has a direct effect on the vehicle and/or the way it is driven (e.g. cruise control system or electronically-controlled suspension) must be approved for use in your vehicle and bear the **e** mark (the European Union's approval symbol).

If any **additional electrical components** are fitted which do not serve to control the vehicle itself (for instance a refrigerator box, laptop or ventilator fan, etc.), these must bear the **CE** mark (manufacturer conformity declaration in the European Union).



WARNING
Never attach accessories (such as cup holders or telephone brackets) to the surfaces covering the airbag units or the areas around the airbags: this could cause injury if the airbag is triggered.



Note

- Since the Audi R8 has an aluminium body, all servicing, repairs or other work on the car body must be carried out by an Audi R8 workshop or a qualified workshop working to the specifications of the Audi factory. This ensures that the necessary repairs or servicing are performed properly and that only Audi Genuine parts® are installed on your vehicle. Use of non-genuine replacement parts, equipment or accessories on your Audi R8, or repair of the vehicle by unqualified persons, may result in serious damage to your car (possibly including corrosion).
- The manufacturer cannot be held liable for damage which occurs as a result of failure to comply with these stipulations, and such damage is not covered under warranty. ■

Modifications

Modifications must always be carried out according to our specifications.

Unauthorised modifications to the electronic components or software in the vehicle may cause malfunctioning. Due to the way the electronic components are linked together in networks, other systems may be affected by the faults. This can seriously impair safety, lead to excessive wear of components, and also invalidate the type approval for your vehicle.

You will appreciate that your Audi R8 dealer cannot be held liable for any damage caused by modifications and/or work performed incorrectly.

We recommend that all work should be performed by an Audi R8 workshop using **Audi Genuine Parts®**.



WARNING

Incorrectly performed modifications or other work on your vehicle can lead to malfunctions and cause accidents. ■

Radio transmitters and business equipment

Radio transmitters (fixed installation)

Retrofit installations of radio transmitters in the vehicle are subject to official approval. Audi generally authorises in-vehicle installations of approved types of radio transmitters provided that:

- the aerial is installed correctly,
- the aerial is not installed in the interior of the vehicle (and screened cables are used together with non-reflective aerial trimming),
- the effective transmitting power does not exceed 10 Watts at the aerial base.

Audi R8 dealers and specialist retailers will be able to inform you about options for installing and operating radio transmitters with a *higher* transmitting power.

Mobile radio transmitters

When using commercial mobile telephones or radio equipment it is possible that they might interfere with the electronics of your vehicle and cause malfunctions. The reasons could be:

- no external aerial

- external aerial incorrectly installed
- transmitting power more than 10 W.

Therefore you must not operate portable mobile telephones or radio equipment *inside the vehicle* without a correctly installed external aerial ⇒

Please note also that the maximum range of the equipment can only be achieved with an *external* aerial.

Business equipment

Retrofit installation of business or other equipment in the vehicle is permitted, provided the equipment cannot interfere with the driver's immediate control of the vehicle. Any such equipment must carry the **CE mark**. Any retrofit equipment that could influence the driver's control of the vehicle must have a type approval for your vehicle and must carry the **e mark**.



WARNING

Mobile telephones or radio equipment which are operated inside the vehicle without a correctly installed external aerial can create excessive magnetic fields that could cause a health hazard.



Note

- Any retrofit installation of electrical or electronic equipment in the vehicle will affect its type approval. In extreme cases this could mean that you might lose the type approval for your vehicle.
- Please refer to the mobile telephone/radio operating instructions. ■

Controls

Safety

Driving tips

General maintenance

Self-help

Technical data



Self-help



Self-help

Breakdown kit

The breakdown kit consists of a warning triangle, first-aid kit, tool kit and the Tyre Mobility System.

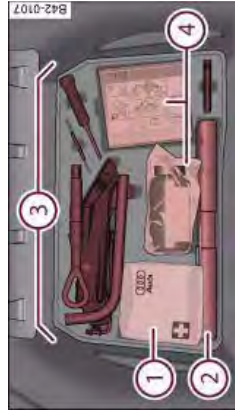

Fig. 123 Breakdown kit in the luggage compartment

- 1 First-aid kit
- 2 Warning triangle
- 3 Tools
- 4 Tyre Mobility System ⇒ page 178

The breakdown kit is located under the floor panel in the luggage compartment.

The tool kit includes:

- Hook for removing wheel covers* or hub caps
 - Box spanner for wheel bolts
 - Pin for mounting a wheel
 - Screwdriver with reversible blade
 - Towline anchorage
 - Jack*
- Before stowing the jack* again, wind down the arm of the jack as far as it will go.

Some of the items listed are only provided on certain models, or are optional extras.

! WARNING

- Do not use the hexagonal socket in the screwdriver handle to tighten the wheel bolts. It is not possible to tighten the bolts with the required torque – risk of accident.
- The jack* supplied with the car is only designed for changing wheels on this model. On no account attempt to use it for lifting heavier vehicles or other loads – risk of injury.
- Never start the engine when the vehicle is on the jack - risk of accident.
- If work has to be done under the vehicle, ensure that it is safely supported on stands designed for the purpose, otherwise there is a risk of injury. ■

Repairing a tyre

General information and safety notes

Repaired tyres are only suitable for temporary use.



Fig. 124 The Tyre Mobility System is NOT suitable for repairing this type of damage to tyres.

Your vehicle is equipped with a tyre repair kit: the **Tyre Mobility System (TMS)**.

In the event of a puncture you will find the **TMS**, which consists of a sealing compound and an electric compressor, located under the floor panel in the luggage compartment.

The **TMS** will reliably seal tyres damaged by foreign bodies, provided that the cuts or punctures are no larger than approx. **4 mm** in diameter.

It is not necessary to remove the foreign body from the tyre.

The sealing compound must not be used:

- on cuts and punctures larger than 4 mm (1) ⇒ page 178, fig. 124
- if the wheel rim has been damaged (2)
- if you have been driving with very low pressure or a completely flat tyre (3).

How to use the **TMS** is described in the section **Repairing a tyre** ⇒ page 180.

The **TMS** can be used at outside temperatures down to $-20\text{ }^{\circ}\text{C}$.

WARNING

After repairing a tyre please note the following points:

- Do not drive faster than 80 km/h.
- Avoid heavy acceleration, hard braking and fast cornering.
- Vehicle handling could be impaired.
- Tyres which have been sealed using the TMS are only suitable for temporary use. Damaged tyres must be renewed. Therefore, please drive carefully to the next available qualified workshop.
- The TMS must NOT be used,
 - on cuts and punctures larger than 4 mm
 - if the wheel rim has been damaged
 - if you have been driving with very low pressure or a completely flat tyre

WARNING (continued)

- Seek professional assistance if the repair of a tyre puncture is not possible with the sealing compound.
- Do not allow the sealant to come into contact with your eyes, skin or clothing.
- If you do come into contact with the sealant immediately rinse the eyes or skin affected with clean water.
- Change clothing immediately if it becomes soiled with the tyre sealant.
- Make sure you do not breathe in the fumes!
- If any of the tyre sealant is accidentally ingested, immediately rinse the mouth thoroughly and drink lots of water.
 - Do not induce vomiting. Immediately contact a doctor!
- If any allergic reactions should occur get medical help immediately.
- Keep the sealant away from children.



For the sake of the environment

Used sealing compound cans should be disposed of at a proper facility.



Note

- If sealant should leak out, leave it to dry. When it has dried, you can pull it off like a piece of foil.
- Observe the expiry date stated on the sealing compound can. Have the sealing compound exchanged by a qualified workshop. ■

Controls

Safety

Driving tips

General maintenance

Self-help

Technical data

Preparations

Certain steps must be taken before repairing a tyre.

- If you have a flat tyre, stop the car well away from moving traffic.
- Apply the **handbrake** firmly.
- Engage a gear.
- Check whether a repair is possible using the Tyre Mobility System ⇒ *page 178*.
- Ensure that all passengers **leave the vehicle** and move away from the danger area ⇒ .
- Take the **tyre sealant can** and the **electric compressor** out of the holder under the floor panel ⇒ *page 178*, fig. 123.
- Peel the sticker "max. 80 km/h" off the tyre sealant can and fix it onto the instrument cluster where the driver will see it.

WARNING

- If you have a puncture in moving traffic, switch on the hazard warning lights and place the warning triangle in a visible location. This is for your own safety and also warns other road users.
- Make sure your passengers wait in a safe place (for instance behind the roadside crash barrier).

Caution

Take special care if you have to repair a tyre on a gradient.

Note

Please observe the relevant regulations. ■

Repairing a tyre

The following sections describe the procedures for repairing a tyre.

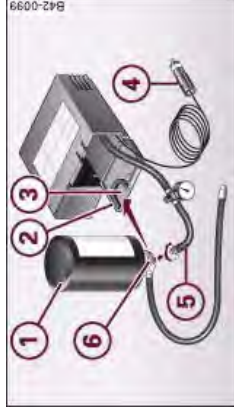

Fig. 125 Components of the Tyre Mobility System

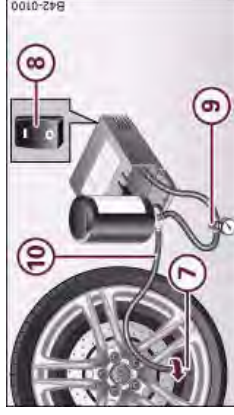

Fig. 126 Connecting the Tyre Mobility System

Setting up the Tyre Mobility System

- Open the flap (2) on the electric compressor ⇒ fig. 125.
- Pull the connector (4) and the compressor hose (5) including the pressure gauge out of the housing.
- Screw the compressor hose (5) onto the flange (6) of the tyre sealant can (1).
- Place the tyre sealant can (flange facing down) into the opening (3) on the flap of the compressor. ▲

- Unscrew the dust cap from the valve of the damaged tyre.
- Screw the filler hose (10) onto the valve (7) ⇒ page 180, fig. 126.
- Insert the connector (4) ⇒ page 180, fig. 125 into the cigarette lighter socket.

Inflating the tyre

- Move the switch (8) ⇒ page 180, fig. 126 on the compressor⁴⁾ to position I. After 5 minutes tyre pressure should be at least 1.8 bar.
- Switch off the compressor by moving switch to position 0. If the necessary tyre pressure of at least 1.8 bar is not reached please follow the instructions given in the section *Re-inflating the tyre*.

Re-inflating the tyre

- Remove the filler hose from the valve and pull the connector out of the socket.
- Slowly move the vehicle forwards and backwards about 10 metres. This enables the sealant to be distributed more evenly.
- Remove the empty tyre sealant can and screw the compressor hose (5) ⇒ page 180, fig. 125 directly onto the valve.
- Insert the connector (4) into the cigarette lighter socket.

- Move the switch (8) ⇒ page 180, fig. 126 on the compressor to position I. After 5 minutes tyre pressure should be at least 1.8 bar.
- Switch off the compressor by moving switch to position 0. If the necessary tyre pressure of at least 1.8 bar is not reached this means that the tyre cannot be repaired using the tyre sealant. You should obtain professional assistance.

Dismantling the Tyre Mobility System

- Remove the filler hose from the valve and pull the connector out of the socket.
- Screw the dust cap onto the valve.
- Put the empty tyre sealant can back into its original packaging and then secure it in the holder under the floor panel in such a way that it will not leak.
- Then drive away immediately so that the tyre sealant can spread evenly in the tyre.

! WARNING

- Please observe the manufacturers' safety notes on the stickers on the compressor and the tyre sealant can.
- If it was not possible to build up a tyre pressure of 1.8 bar within 5 minutes this means that the tyre is too badly damaged. Do not drive on.
- Seek professional assistance if the repair of a tyre puncture is not possible with the sealing compound.

4) The compressor should never be used for longer than 8 minutes.

i Note

- Do not use the compressor for longer than 8 minutes at a time, as it could overheat. When the compressor has cooled down, you can use it again.
- If tyre sealant should leak out, leave it to dry and then pull it off like foil. ■

Final check

After covering a short distance it is necessary to check the tyre pressure

- After about 10 minutes stop to check the tyre pressure.
- If tyre pressure is still at least 1.3 bar, pump the tyre up to the pressure specified (see driver's door pillar) and drive to the nearest workshop to have the tyre and the tyre sealant can replaced.
- If tyre pressure is less than 1.3 bar, the tyre is too badly damaged. Do not drive on. You should obtain professional assistance.

⚠ WARNING

If tyre pressure is less than 1.3 bar after driving about 10 minutes, the tyre is too badly damaged. Do not drive on. You should obtain professional assistance.

i Note

After carrying out repairs to a tyre, have the tyre sealant can replaced by a qualified dealer. This will ensure that the Tyre Mobility System is operative again. ■

Changing a wheel**Tyres with directional tread pattern**

Tyres with directional tread pattern must be mounted so that they rotate in the correct direction.

A directional tread pattern is identified by **arrows on the sidewall** pointing in the forward running direction. Always note the direction of rotation indicated when mounting the wheel. This is important so that these tyres can give maximum grip and avoid excessive noise, tread wear and aquaplaning. ■

Applies to vehicles: with anti-theft wheel bolts

Anti-theft wheel bolts

A special adapter is required to turn the anti-theft wheel bolts.



Fig. 127 Anti-theft wheel bolt with adapter

- Insert the adapter (2) completely into the anti-theft wheel bolt (1).
- Fit the box spanner as far as it will go over the adapter (2).
- Loosen or tighten the wheel bolt ⇒ page 185. ▲

It is advisable to carry the wheel bolt adapter in the vehicle. It should be stored with the tool kit.

The **code number** of the anti-theft wheel bolt is stamped on the front of the adapter. Your Audi R8 dealer will need this number to replace the adapter if lost.

Note

Note the code number of the anti-theft wheel bolt and keep it in a safe place – not in your vehicle. ■

Applies to vehicles: with jack

Raising the vehicle

The vehicle must be raised with a jack to remove the wheel.



Fig. 128 Changing a wheel: Jacking point



Fig. 129 Changing a wheel: Jack

- Look for the **jacking point** under the door sill ⇒ fig. 128.
- Raise the jack until it is standing just below the jacking point.
- Align the jack so that the arm of the jack ⇒ fig. 129 (A) fits into the jacking point and the movable base plate of the jack (B) is flat on the ground.
- Raise the vehicle until the defective wheel is clear of the ground.

The jack may **only** be applied at the jacking points shown ⇒ fig. 128. There is **one** jacking point on each side of the vehicle. Do not apply the jack anywhere else.

An **unstable surface** under the jack may cause the vehicle to slip off the jack. Always provide a firm base for the jack on the ground. If necessary use a large, strong board or similar support. On a **hard, slippery surface** (such as tiles) use a rubber mat or similar to prevent the jack from slipping.

WARNING

- Prevent the base of the jack from slipping – risk of injury.

WARNING (continued)

- The car can be damaged if the jack is not applied at the correct jacking points. There is also a risk of injury since the jack can slip off suddenly if it is not properly engaged.

Caution

A trolley jack or lifting platform must **not** be applied at the points shown ⇒ *page 183*, fig. 128 -arrows-. ■

Taking off / putting on the wheel

Step-by-step instructions for taking off and putting on the wheel.



Fig. 130 Changing a wheel: Mounting pin in wheel bolt hole nearest to the top

Change the wheel as described below after loosening the wheel bolts and raising the vehicle with the jack.

Taking off the wheel

- Using the **hexagonal opening** in the screwdriver handle (provided in the vehicle's tool kit), unscrew the wheel bolt nearest to the **top** and place the bolt on a clean surface.

- Screw in the **mounting pin** (provided in the vehicle's tool kit) by hand in place of the wheel bolt ⇒ fig. 130.
- Then unscrew the other wheel bolts as described above.
- Take off the wheel ⇒ . The mounting pin stays where it is.

Putting on the wheel

- Put on the spare wheel, using the mounting pin to guide it into place ⇒ .
- Screw in the wheel bolts and tighten them *lightly* using the hexagonal opening in the screwdriver handle.
- Then unscrew the mounting pin and tighten the remaining wheel bolt lightly.

The wheel bolts should be clean and turn easily. Before putting on the wheel, inspect the condition of the wheel and hub mounting surfaces. These surfaces must be clean before mounting the wheel. The hexagonal opening in the screwdriver handle makes it easier to turn the wheel bolts when they are loose. The reversible screwdriver blade should be removed when the tool is used for this purpose.

Note the direction of rotation when putting on a tyre with **directional tread pattern** ⇒ *page 182*.

Caution

When removing/fitting the wheel the rim may hit and damage the brake disc. For this reason, please take care and get a second person to assist you.

Note

Do not use the hexagonal socket in the screwdriver handle to loosen or tighten the wheel bolts. ■

Tightening wheel bolts

- Fit the box spanner as far as it will go over the wheel bolt⁵⁾.
- Grip the box spanner as close to the *end* as possible and tighten the bolt firmly by turning **clockwise**.

Have the **tightening torque** of the wheel bolts checked as soon as possible with a torque wrench. The correct tightening torque is 120 Nm.

The **inflation pressure** must be checked as soon as possible. Put the tools and jack back in the luggage compartment.



WARNING

The wheel bolts must not be loosened – this would cause a safety risk.



Note

- Do not use the hexagonal socket in the screwdriver handle to loosen or tighten the wheel bolts.
- If you notice that the wheel bolts are corroded and difficult to turn, they must be replaced before having the tightening torque checked.
- In the interest of safety, drive at moderate speeds until the tightening torque of the wheel bolts has been checked. ■

⁵⁾ An adapter is required to tighten the anti-theft wheel bolts ⇒ page 182.

Jump-starting

Before starting the engine

If necessary, the engine can be started by connecting it to the battery of another vehicle.

If the engine should ever fail to start because of a discharged battery, the battery can be connected to the battery of another vehicle to start the engine. Suitable **jump leads** are required.

Both batteries must be rated at 12 Volts. The **capacity** (Ah) of the booster battery should not be significantly lower than that of the discharged battery.

Jump leads

The jump leads must be **heavy enough** to carry the starter current. Refer to the details given by the manufacturer.

Only use jump leads with *insulated* battery clamps.

Positive cable – usually red

Negative cable – usually black



WARNING

- When it is discharged the battery can freeze at temperatures around 0°C. A frozen battery must first be thawed out before connecting the jump leads, as it could otherwise explode.
- Please note the safety warnings referring to working in the engine compartment ⇒ page 155.



Note

- There must be no contact between the two vehicles as otherwise current could flow as soon as the positive terminals are connected.
- The discharged battery must be properly connected to the vehicle's electrical system. ▲

- Switch off the car telephone if necessary. Details will be given in the manufacturer's instructions for the car telephone. ■

Starting the engine

The jump leads must be connected in the correct sequence.

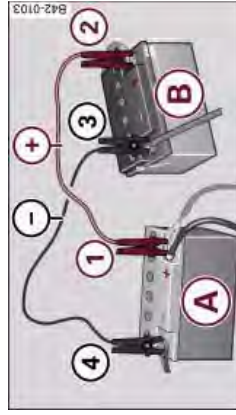

Fig. 131 Jump-starting with the battery of another vehicle: A – Discharged battery, B – Boosting battery

The battery is located in the luggage compartment ⇒ *page 163*. The luggage lid can be released manually if necessary ⇒ *page 48*.

Connecting the positive terminals with the positive lead (red)

1. Connect one end of the positive lead to the positive terminal ① of the discharged battery (A).
2. Connect the other end of the positive lead to the positive terminal ② of the boosting battery (B).

Connecting negative terminals with the negative lead (black)

3. Connect one end of the negative lead to the negative terminal ③ of the boosting battery (B).

4. Connect the other end of the negative lead to the negative terminal ④ of the discharged battery (A).

Starting the engine

- Start the engine of the vehicle with the boosting battery and let it run at idling speed.
- Now start the engine of the vehicle with the discharged battery.
- If the engine fails to start: do not operate the starter for longer than 10 seconds. Wait for about 30 seconds and try again.
- When the engine is running, disconnect the leads in exactly the *opposite* sequence.

The battery is vented to the outside to prevent gases entering the vehicle's interior.

Connect the battery clamps so they have good *metal-to-metal* contact with the respective terminals.

⚠ WARNING

- The non-insulated parts of the battery clamps must not be allowed to touch. The jump lead attached to the positive battery terminal must not touch metal parts of the vehicle: this can cause short circuiting.
- Position the jump leads in such a way that they cannot come into contact with any moving parts in the engine compartment.
- Do not bend over the batteries – risk of acid burns.
- The screw plugs on the battery cells must be screwed in firmly.
- Keep sparks, flame and lighted cigarettes away from batteries: the gases given off can cause an explosion.

! **Caution**

Please note that the described method of connecting the leads is meant for jump-starting your vehicle. If jump-starting another vehicle, you should not connect the negative lead (–) to the negative terminal of the discharged battery ⇒ *page 186*, fig. 131 (4), but directly to the engine block or a solid metal part bolted to the engine block. If the battery of the other vehicle does not have a gas vent, there is a risk that a mixture of oxygen and hydrogen gas can accumulate and cause an explosion. ■

Tow-starting and towing away**General notes**

Points to observe when tow-starting or towing away

If you use a towrope:

Notes for the driver of the towing vehicle

- The towrope must be taut before driving off.
- Engage the clutch very gently when starting to move (press the accelerator slowly if you have R tronic).

Notes for the driver of the towed vehicle

- The ignition should be switched on so that the turn signals, horn, windshield wipers and washers can be used. Please ensure that the steering wheel is unlocked when you switch on the ignition and that it moves freely.
- Put the gear lever in neutral or move the selector lever to position N.

- The brake servo and power steering only work when the engine is running. Considerably more effort is required on the brake pedal and steering wheel when the engine is switched off.
- Ensure that the towrope remains taut at all times when towing.

Towrope or towbar

It is easier and safer to tow a vehicle with a towbar. You should only use a towrope if you do not have a towbar.

A towrope should be slightly elastic to reduce the loading on both vehicles. It is advisable to use a **towrope made of synthetic fibre** or similar material.

Attach the towrope or the towbar only to the **towing anchorages** provided for this purpose ⇒ *page 188*.

Driving technique

Towing requires some experience – especially when using a towrope. Both drivers should be familiar with the technique required for towing. Inexperienced drivers should not attempt to tow-start or tow away another vehicle.

Do not pull too hard with the towing vehicle and take care to avoid jerking the towrope. When towing on a loose surface there is always a risk of overloading and damaging the anchorage points.

! **Caution**

If there is no oil in the gearbox or no lubricant in the automatic transmission the car may only be towed with the driven wheels lifted clear of the road, or transported on a special car transporter or trailer.

? Note

- Note the regulations concerning towing. ▲

- The hazard warning lights of both vehicles must normally be switched on. However, observe any regulations to the contrary.
- Make sure that the towrope is not twisted, as otherwise the front towline anchorage on your vehicle could work itself loose. ■

Front towline anchorage

The front towline anchorage is only mounted if the vehicle has to be towed.



Fig. 132 Detail from front of vehicle, right side with air intake grille removed: Towline anchorage screwed in

The towline anchorage is screwed **anti-clockwise** into the screw connection (left-hand thread) which is located on the right side of the front bumper behind the air intake grille.

- Take the towline anchorage out of the vehicle's tool kit ⇒ page 178.
- Pull the bottom part of the grille out.
- Screw the towline anchorage firmly all the way into the screw connection ⇒ fig. 132.

After use, unscrew the towline anchorage and put it back in the toolbox. The towline anchorage should always be kept in the vehicle.

When refitting the air intake grille, first insert the lugs on the grille into their mountings in the intake duct. Then press the grille firmly back into place.

⚠ WARNING

If the towline anchorage is not screwed in as far as the stop, there is a risk of the screw connection shearing off during towing (accident risk). ■

Tow-starting

As a general rule, tow-starting is not recommended.

Vehicles with manual gearbox

- Engage 2nd or 3rd gear before moving off.
- Press the clutch and hold the pedal down.
- Switch on the ignition.
- Once both vehicles are moving, release the clutch.
- As soon as the engine starts: press the clutch and put the gear lever in neutral.

Vehicles with R tronic

- Switch on the ignition.
- When both vehicles are moving, engage a gear using the selector lever or the paddle levers. Which gear is selected will depend on how fast the vehicle is travelling.
- As soon as the engine starts: Put the gear lever in neutral.

If the engine will not start, it is best to try starting it using the battery of another vehicle ⇒ page 185 before attempting to tow start. You should only try to tow-start the engine if jump-starting is

not successful. Tow-starting is an attempt to start the engine via the movement of the wheels.

When tow-starting a vehicle with a **petrol engine**, do not tow it more than a *short* distance, otherwise unburnt fuel can enter the catalytic converter and cause damage.



WARNING

There is a high risk of accidents when tow-starting, as the towed vehicle can easily be driven into the towing vehicle.



Caution

When tow-starting the vehicle, do not tow it further than 50 metres; otherwise the catalytic converter could be damaged. ■

Towing away

Certain restrictions must be observed when towing your vehicle.

Please observe the notes ⇒ *page 187*.

The vehicle can be towed with a towbar or towrope in the normal way, with all four wheels on the ground. When doing so, please note the following points:

- Make sure the gear lever is in neutral or the selector lever is in the **N** position.
- The vehicle must not be towed faster than **50 km/h**.
- The vehicle must not be towed further than **50 km**. The reason for this is: when the engine is not running, the gearbox oil pump does not work and the gearbox is not adequately lubricated for higher speeds or longer distances.



Caution

The vehicle must not be towed with the wheels lifted at either the front or rear otherwise the gearbox may be damaged.



Note

If it is not possible to tow the vehicle as described above, or if it has to be towed further than 50 km, it must be transported on a special car transporter or trailer. ■

Fuses and bulbs

Fuses

Changing fuses

If a fuse has blown it must be replaced.

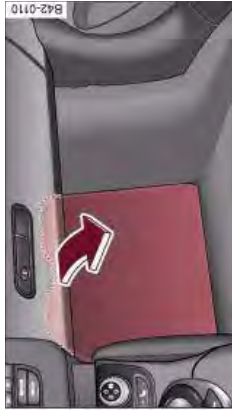

Fig. 133 Passenger's footwell: Foot rest/fuse box

The various electrical circuits are protected by fuses. The fuses are located behind a cover in the passenger's footwell.

- Switch off the ignition and the component concerned.
- Remove the floor mat.
- Fold out the foot rest ⇒ fig. 133.
- Identify the fuse for the failed component ⇒ *page 190*, "Fuse list".
- Take the plastic clip from inside the fuse box, fit it onto the blown fuse, and pull the fuse out.
- Replace the blown fuse (which will have a melted metal strip) with a new fuse of the same amp rating.
- Fold the foot rest back into place.



Caution

Never attempt to "repair" a fuse or replace it by fitting a fuse with a higher rating - risk of fire! It could also cause damage to other parts of the electrical system.



Note

- If a newly replaced fuse blows again after a short time, the electrical system must be checked by a qualified workshop as soon as possible.
- It is advisable to carry several spare fuses at all times. They are available from Audi R8 dealers and specialist retailers. ■

Fuse list

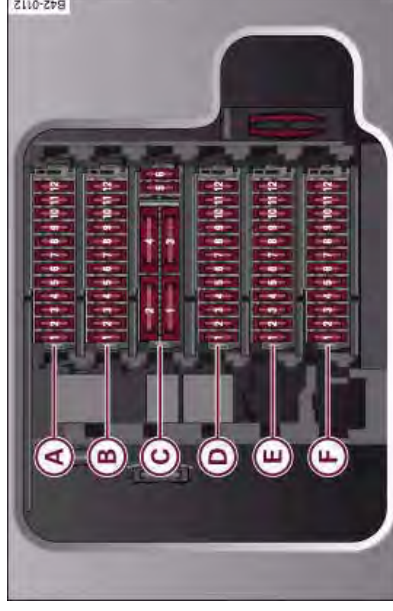

Fig. 134 Fuse layout in passenger's footwell, rows A to F

The fuse box is located behind the foot rest in the passenger's footwell ⇒ *page 190*, fig. 134.

Row (A) of the fuse box is not used.

Row	No	Electrical equipment	amps
(B)	1	Mobile phone adapter	5
	2	Heated washer jets	5
	3	Parking aid (APS)	10
	4	Vacant	--
	5	Diagnostic interface, light switch, Airbag OFF warning lamp, selector lever	10
	6	Network gateway, diagnostic interface	5
	7	Vacant	--
	8	Anti-dazzle interior mirror, garage door opener	10
	9	Washer pump	15
	10	ESP button	10
	11	Pressure sensor, air conditioner	5
	12	Airbag	5

Fuse row -B-

Row	No	Electrical equipment	amps
(C)	1	Radiator fan (1)	40
	2	Radiator fan (2)	40
	3	Exterior lighting	40
	4	Exterior lighting	40
	5	Vacant	--
	6	Blower control	40

Fuse row -C-

Row	No	Electrical equipment	amps
(D)	1	Reversing camera	5
	2	Tyre pressure monitoring	10
	3	Parking aid (APS)	5
	4	Phone pre-installation, compensator	5
	5	Instrument cluster	5
	6	Network gateway	5
	7	Switches for steering column	5
	8	Diagnostic interface, brake pedal switch, selector lever	10
	9	Rain sensor/light sensor	5
	10	Interior lighting	5
	11	Sound amplifier	30
	12	Radio	20

Fuse row -D-

Row	No	Electrical equipment	amps
(E)	1	Vacant	--
	2	Vacant	--
	3	Auxiliary water pump	10
	4	Optional equipment	5
	5	Power supply, terminal 15, starter	30
	6	Pump for brake servo	15
	7	Horn	20
	8	Wiper motor	30
	9	Wiper motor	30
	10	Headlight washer system	30
	11	Electrically heated rear window	30
	12	Electrical sockets and cigarette lighter	20

Fuse row -E-

Row	No	Electrical equipment	amps
(F)	1	Electronic stabilisation program	10
	2	Electronic stabilisation program	25
	3	Vacant	--
	4	Vacant	--
	5	Control unit for convenience electronics	20
	6	Control unit for convenience electronics	20
	7	Level sensor (ASS), anti-theft alarm	5
	8	Air conditioner	10
	9	Seat heating	25
	10	Lumbar support	10
	11	Electric windows	30
	12	Control unit for doors	10

Fuse row -F-

Some of the items listed are only fitted on certain models or are optional extras.

The electric windows and electric seat adjusters are protected by **circuit breakers**. These reset automatically after a few seconds when the overload (caused for example by frozen windows) has been corrected.



Note

Please note that the above list, while correct at the time of printing, is subject to alterations. ■

Bulbs

Note

Your vehicle is fitted with maintenance-free headlights and rear lights. If you do need to change a bulb, please contact your Audi R8 dealer or specialist retailer. ■

Technical data

Self-help

General maintenance

Driving tips

Safety

Controls





General notes

Notes

Where not otherwise indicated or separately listed, all technical data apply to vehicles with standard equipment for the German market. Other figures may apply for special versions and export models.

Please note that the details listed in the **vehicle's registration documents** can be taken as correct.

Engine data

The figures for engine power output are determined according to EU standards. Slight variations are possible due to the different test methods.

Performance figures

The performance figures were measured without equipment which may influence performance, such as mudflaps or extremely wide-section tyres.

Kerb weight (unladen weight)

These figures (kerb weight according to the currently applicable version of EU Directive 92/21/EEC) apply to the vehicle with the tank 90% full, with no special equipment. The figures include an additional 75 kg to allow for the weight of the driver. ■

Vehicle identification data

The most important data are given on the type plate and the vehicle data sticker.

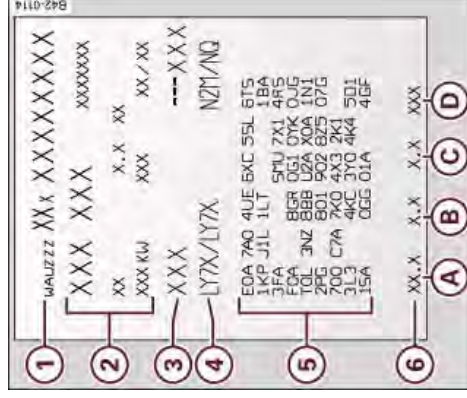

Fig. 135 Vehicle data sticker

Type plate

The type plate is located on the passenger's door pillar. Vehicles for certain export countries have no type plate. ▲

Vehicle identification number⁶⁾

The vehicle identification number (chassis number) can be found behind the windscreen (bottom left).

Vehicle data sticker

The vehicle data sticker ⇒ *page 196*, fig. 135 is located together with the fuses in the passenger's footwell ⇒ *page 190*. One section of the vehicle data sticker is attached to the inside cover of the Service Schedule before the vehicle is handed over.

The sticker lists the following data:

- ① Vehicle identification number (chassis number)
- ② Vehicle type / engine power / gearbox type
- ③ Engine and gearbox code letters
- ④ Paint No. / Interior equipment No.
- ⑤ Optional equipment codes
- ⑥ Fuel consumption and emissions

Fuel consumption and emissions

Information on the vehicle's fuel consumption and emissions is given at the bottom of the vehicle data sticker ⑥:

- A Urban cycle consumption (ltr./100 km)
- B Extra-urban cycle consumption (ltr./100 km)
- C Combined cycle consumption (ltr./100 km)
- D Combined CO₂ emissions (g/km)

The specified values were determined in accordance with the test procedure prescribed by the currently applicable version of Directive 80/1268/EEC. The specifications do **not** refer to an individual vehicle. Other consumption figures may be achieved during normal driving, depending on special equipment fitted, vehicle loading, personal driving style, road and traffic conditions, environmental factors and the condition of the car. ■

⁶⁾ On some models you can also call up the vehicle identification number on the menu display.

Controls

Safety

Driving tips

General maintenance

Self-help

Technical data

Performance, weights and dimensions

Performance, weights and dimensions

R8 4.2 quattro

Engine data

Power output	309 kW at 7800 rpm
Maximum torque	430 Nm at 4500 to 6000 rpm
Cylinders, capacity	8 cylinders, 4163 cm ³
Valves per cylinder	4
Bore	mm 84.5
Stroke	mm 92.8
Compression ratio	12.5:1
Firing order	1-5-4-8-6-3-7-2
Fuel	Super Plus unleaded 98 RON or premium unleaded not less than 95 RON ¹⁾

Performance figures

Maximum speed	km/h 301
Acceleration from 0 - 100 km/h sec.	4.6
Acceleration from 0 - 200 km/h sec.	14.9

Weights

Gross vehicle weight	kg	MG = 1860	AG = 1865
Kerb weight (unladen weight)	kg	MG = 1560	AG = 1565
Maximum front axle weight	kg	MG = 890	AG = 890
Maximum rear axle weight	kg	MG = 1050	AG = 1055

Engine oil

<i>LongLife Service</i>	VW 504 00
<i>Inspection Service</i>	VW 502 00, VW 504 00
Engine oil capacity (including filter change)	approx. 10 litres

MG = Manual gearbox / AG = Automatic gearbox (R tronic)

¹⁾ With slight loss of power ■

Dimensions

Length	mm 4431
Width	mm 1904
Width across mirrors	mm 2029
Height, unladen ¹⁾	mm 1252
Turning circle diameter	m 11.80

¹⁾ The height of the vehicle depends on the tyres and suspension. Take care not to damage low-mounted parts of the car (such as the spoiler or exhaust system) on steep ramps, uneven road surfaces or roadside kerbs, etc.

Take particular care if the car has lowered (sports) suspension or if it is fully laden. ■

Capacities

Fuel tank

ltr. 75 / 90*

Windscreen washer

ltr. approx. 4.0

Windscreen and
headlight washer system*

Controls

Safety

Driving tips

General maintenance

Self-help

Technical data

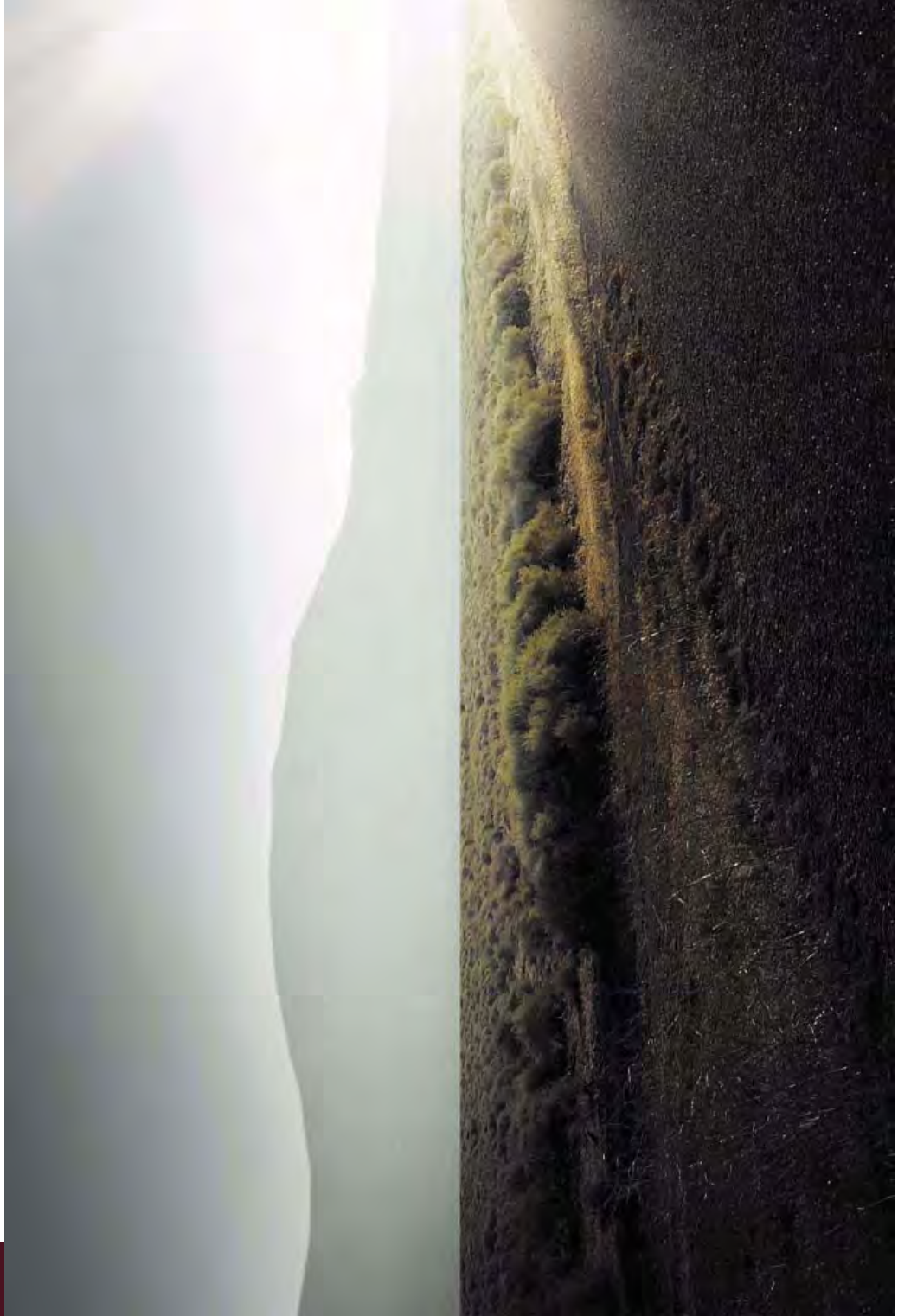

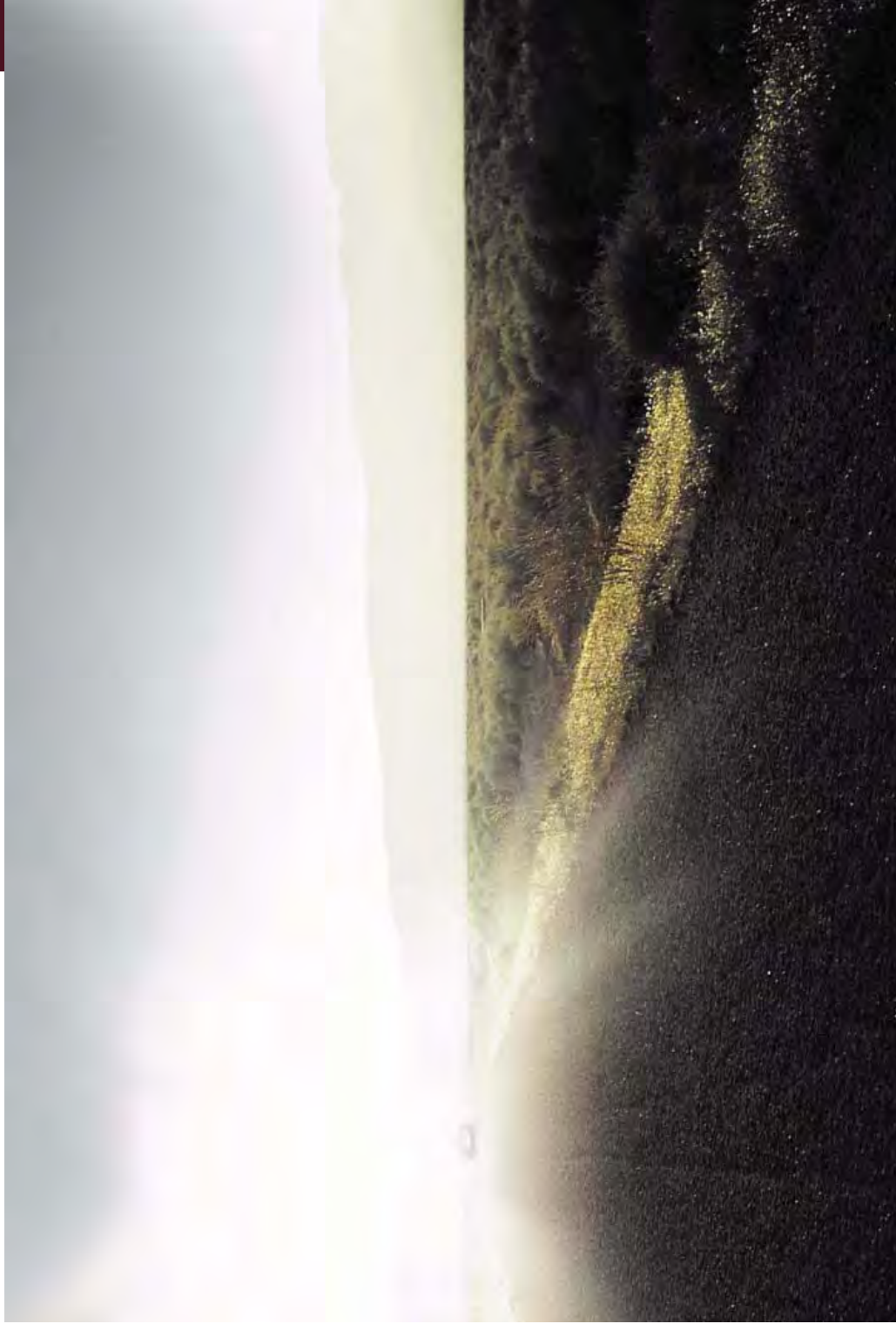

- A**
- Airbag 115
 - Deactivating 120
 - Front airbags 116
 - Key-operated switch for front passenger's airbag 120
 - Side airbags 118
 - Triggering 116
 - Warning lamp 17
 - Alterations to the vehicle 174
 - Alternator 18
 - Warning lamp 18
 - Anti-dazzle interior mirror 63
 - Anti-freeze additive 159
 - Anti-knock properties of petrol 152
 - Anti-lock brake system 132
 - Warning lamp 19
 - Anti-theft alarm 48
 - Interior monitor 49
 - Tow-away protection 49
 - Anti-theft wheel bolts 182
 - Ashtray 72
 - Audi magnetic ride 16, 88
 - Description 88
 - Warning lamp 16
 - Audi parking system 85
 - Automatic car washes
 - See Washing 144
 - Automatic headlight control 63
 - Automatic headlights 53
 - Defective 38
 - Average fuel consumption 22
 - Average speed 22
- B**
- Battery 162
 - Charging 164
 - Disconnecting and connecting 162
 - Long periods of non-use 162
 - Replacing 162
 - Testing 162
 - Winter conditions 162
 - Winter operation 162
 - Battery voltage 37
 - Belt tensioners 114
 - Bioethanol fuel 152
 - Blower 77
 - Brake system
 - Brake fluid 161
 - Brake light failure 38
 - Brake pads worn 37
 - Brake servo 134
 - Brakes 134
 - Malfunction 35
 - Warning lamp 18
 - Bulb monitor 37
 - Bulbs 193
 - Business equipment 175
- C**
- Capacities 199
- See Performance, weights and dimensions** 198

- Car keys 40
- Cleaning seat covers
Alcantara 150
Natural leather 149
Textile covers 147
- Care of vehicle 144
- Cleaning textile covers and trim parts .. 147
- Closing
- Catalytic converter 138
- Central locking system 42
- Deadlock mechanism 44
- Locking 44
- Locking and unlocking the vehicle from inside 45
- Locking doors manually 46
- Luggage lid 47
- Opening and closing windows 43
- Security central locking 46
- Switches 45
- Unlocking 44
- Ceramic brake discs
- Changing a wheel 184
- Changing a wheel 182
- Changing bulbs 193
- Chassis number 196
- Child safety 122
- Child safety seat 123
- Child seat categories 123
- Fitting 126
- ISOFIX system 128
- Safety notes 122
- Cigarette lighter 72
- Cleaning 144
- Cleaning Alcantara 150
- Car keys 40
- Cleaning seat covers
Alcantara 150
Natural leather 149
Textile covers 147
- Care of vehicle 144
- Cleaning textile covers and trim parts .. 147
- Closing
- Catalytic converter 138
- Central locking system 42
- Deadlock mechanism 44
- Locking 44
- Locking and unlocking the vehicle from inside 45
- Locking doors manually 46
- Luggage lid 47
- Opening and closing windows 43
- Security central locking 46
- Switches 45
- Unlocking 44
- Ceramic brake discs
- Changing a wheel 184
- Changing a wheel 182
- Changing bulbs 193
- Chassis number 196
- Child safety 122
- Child safety seat 123
- Child seat categories 123
- Fitting 126
- ISOFIX system 128
- Safety notes 122
- Cigarette lighter 72
- Cleaning 144
- Cleaning Alcantara 150
- Dashboard lighting
See Instrument lighting 55
- Date display 12
- Daytime running lights 52
- Deactivating front passenger's airbag .. 120
- Deadlock mechanism 44
- Defrosting windows 78
- Deluxe automatic air conditioner
Economical operation 79
Description of R tronic 90
- Digital clock 12
- Digital compass 65
- Dimensions 198
- Dipped headlights 52
- Defective 37
- Distance covered 23
- Door catches, engine lid and front lid warning 20
- Doors
Locking doors manually 46
Driver
See Sitting position 104
- Driver information system
CD and radio display 20
- Door catches, engine lid and front lid warning 20
- Help 25
- Menu button 25
- Menu display 24
- On-board computer 22
- Outside temperature display 20
- D
- Dashboard lighting
See Instrument lighting 55
- Date display 12
- Daytime running lights 52
- Deactivating front passenger's airbag .. 120
- Deadlock mechanism 44
- Defrosting windows 78
- Deluxe automatic air conditioner
Economical operation 79
Description of R tronic 90
- Digital clock 12
- Digital compass 65
- Dimensions 198
- Dipped headlights 52
- Defective 37
- Distance covered 23
- Door catches, engine lid and front lid warning 20
- Doors
Locking doors manually 46
Driver
See Sitting position 104
- Driver information system
CD and radio display 20
- Door catches, engine lid and front lid warning 20
- Help 25
- Menu button 25
- Menu display 24
- On-board computer 22
- Outside temperature display 20

Controls

Safety

Driving tips

General maintenance

Self-help

Technical data

- Red symbols 33
 Service interval display 21
 Setting 26
 Yellow symbols 33
 Driver messages 34
 Driving abroad 138
 Headlights 138
 Unleaded fuel 138
 Driving away on a slope
 hill hold assist 84
 Driving safety 103
 Driving time 22
 Dry sump lubrication system 137
 Dust filter 76
- E**
- Electric fuses 190
 Electric seat adjustment
 See Seat adjustment 68
 Electric voltage 14
 Electric windows 50
 Central locking system 43
 Possible malfunctions 50
 Electrical socket 72
 Electrical system 18
 Electronic differential lock 132
 Warning lamp 19
 Electronic immobiliser 42
 Electronic stabilisation program 132
 Emission control systems 138
 Emissions 196
- Engine compartment
 Lighting 58
 Safety notes 155
 Engine compartment layout 156
 Engine data
 See Performance, weights and
 dimensions 198
 Engine hood
 See Engine lid 155
 Engine lid
 Closing 156
 Opening 155
 Engine oil 157
 Checking oil level 157
 Consumption 157
 Dry sump lubrication system 137
 LongLife Service 157
 Temperature gauge 10
 Topping up 158
 See also Performance, weights and
 dimensions 198
 Engine oil capacity
 See Performance, weights and
 dimensions 198
 Engine oil pressure (too low) 36
 Engine oil sensor defective 37
 Environmental compatibility 139
 Environmental tips
 Filling the tank 153
 Leaks 156
 Warming up the engine 82
 EPC warning lamp 16
- ESP 16
 See also Electronic stabilisation program
 132
 Ethanol fuel 152
 Exterior mirrors 64
- F**
- Filling the tank 152
 Releasing the tank flap manually ... 154
 First-aid kit 178
 Floor mats 107
 Foreign countries
 See Driving abroad 138
 Four-wheel drive 136
 Front passenger
 See Sitting position 105
 Fuel
 Capacity 199
 Consumption 196
 Current consumption 22
 Ethanol 152
 Fuel gauge 13
 Fuel level low 36
 Petrol 152
 Fuel consumption 196
 Fuel gauge 13
 Fuel range 22
 Fuses
 Changing 190
 Fuse list 190

- G**
- Garage door opener 95
 - Gearbox (R tronic) 90
 - Glove box 73
- H**
- Handbrake 83
 - Handbrake warning lamp 35
 - Hazard warning lights 56
 - Indicator lamp 17
 - Head restraints 71
 - Headlight flasher 57
 - Headlight range control
 - Malfunction 37
 - Headlight switch (automatic) 53
 - Headlights
 - Changing dip settings 138
 - Washer system 60
 - Heated
 - Exterior mirrors 64
 - Washer jets 59
 - Heating 75
 - Front seats (air conditioner) 80
 - Rear window 79
 - Seats 80
 - hill hold assist
 - Driving away on a slope 84
 - HomeLink 95
 - Horn 9
- I**
- Ignition lock 81
 - Immobiliser 42
 - Indicator lamps 15
 - Cruise control system 17
 - Main beam headlights 17
 - Turn signals 17
 - Inflation pressures (tyres) 167, 172
 - Inspection intervals 21
 - Instrument cluster 10
 - Instrument lighting 55
 - Interior lights 57
 - Engine compartment 58
 - Luggage compartment 58
 - Interior mirrors
 - See Mirrors 63
 - Interior monitor 49
 - Intermittent wipe 59
 - ISOFIX 128
- J**
- Jack 183
 - Jacking points 183
 - Journey distances 13
 - Jump-starting 185
- K**
- Key-operated switch for front passenger's airbag 120
- L**
- Lap timer
 - Calling up 28
 - Clearing overall results 30
 - Displaying split times 29
 - Evaluating lap times 30
 - Finishing the session 30
 - Interrupting 29
 - Introduction 27
 - Resuming the session 31
 - Starting 28
 - Switching to on-board computer 30
 - Launch control programme
 - R tronic 93
 - Leather care
 - Alcantara 150
 - Natural leather 149
 - Leaving home function 54
 - Light 58
 - Light sensor/rain sensor
 - Automatic headlights 63
 - Defective 38
 - Headlight switch (automatic) 53
 - Windscreen wipers (intermittent wipe) 59
- Keys** 40
- Remote control key 40
 - Replacement keys 40
 - Replacing the battery 41
 - Spare key 40
 - Kick-down feature
 - R tronic 92

- Lights 52
- Switching on and off 52
- Locking 43
- Central locking system 44
- Locking and unlocking the vehicle from in-side 45
- Central locking system 45
- Locking passenger's door manually 46
- Long periods of non-use 46
- Battery 162
- LongLife Service 157
- Luggage compartment 58
- Light 58
- Luggage lid 47
- Central locking system 47
- Manual release 48
- M**
- Main beam headlights 52, 56
- Make-up mirrors 58
- Manual operation
- Fuel tank flap 154
- Luggage lid 48
- Maximum speed
- See Performance, weights and dimensions 198
- Menu button 25
- Menu display 24
- Menu, changing settings 26
- Mileage recorder 13
- Mirrors 63
- Anti-dazzle setting 63
- Automatic anti-dazzle exterior mirrors 64
- Automatic anti-dazzle interior mirror 63
- Exterior mirrors 64
- Interior mirror 63
- Make-up mirrors 58
- Mobile phones 175
- Modifications 174
- N**
- Natural leather 148
- No R gear 38
- O**
- Octane rating 152
- Oil
- See Engine oil 157
- Oil consumption 157
- Oil dipstick 157
- Oil level 37
- On-board computer 22
- Opening
- Engine lid 155
- Outside temperature display 20
- Overview 9
- P**
- Paint damage 146
- Paint No. 196
- Parking
- R tronic 91
- Parking aid 85
- Parking lights 57
- Parking the car 84
- Pedals 107
- Performance figures
- See Performance, weights and dimensions 198
- Performance, weights and dimensions 198
- Personalised remote control key 41
- Petrol 152
- Polishing 144
- Pollen filter 76
- Pollution filter 76
- Power steering 136
- Pressure (tyres) 172
- Q**
- Quartz clock 12
- quattro
- See Four-wheel drive 136
- R**
- R tronic 90
- Backup programme 94
- Description 90
- Kick-down feature 92
- Launch control programme 93
- Manual mode 91
- Steering wheel with paddle levers 93

- Radio display 20
 Radio transmitters
 Fixed installation 175
 Mobile equipment 175
 Radio-controlled clock 11
 Radio-operated remote control
 See Remote control keys 41
 Rain sensor 59
 Rain sensor defective 38
 Rain fog light 54
 Rear lights defective 37
 Rear spoiler 134
 Rear view mirrors
 See Mirrors 63
 Rear window heating 79
 Remote control keys 40
 Indicator lamp 40
 Replacing the battery 40, 41
 Synchronisation 41
 Unlocking and locking 43
 Repairs 174
 Replacement keys 40
 Replacement parts 174
 Rev counter 11
 Reverse gear
 R tronic 90
 Running in 138
- S**
 SAFE 42
 Safe driving 102
- Safety 103
 Safety features 102
 Seat adjustment
 Bucket seats 70
 Electrically adjustable seat 68
 Manually adjustable seat 67
 Seat belts 109
 Adjusting seat belts 112
 Belt tensioners 114
 Cleaning 150
 During pregnancy 113
 Putting on 112
 Safety notes 110
 Taking off 113
 Warning lamp 18
 Seat heating 80
 Security central locking 46
 Selector lever defective 38
 Service interval display 21
 Service position for windshield wipers 61
 Setting time 12
 Setting time format 12
 Side lights 52
 Sitting position
 Driver 104
 Front passenger 105
 Incorrect sitting position 106
 Snow chains 171
 Spare key 40
 Speed warning 31, 37
 Speedometer 13
 Spoiler 134
- Starting the engine 82
 Starting with jump leads 185
- Steering
 Locking the steering 81
 Steering wheel height adjustment
 (manual) 81
 Steering lock 81
 Stowing luggage safely 108
 Sun visors 58
 Switching off the engine 83
 Symbols
 Red symbols in central display 33
 Yellow symbols in central display 33
- T**
 Tank capacity 199
 Temperature 76
 Tool kit 178
 Tools 178
 Tow-away protection 49
 Towing away 187
 Towline anchorage 188
 Tow-starting 187
 Traction control system 132
 Tread depth 168
 Trip recorder 13, 14
 Trips, checklist 102
 Turn signals 56
 Two-way radios 175
 Type plate 196
 Tyre Mobility System 178

- Tyre pressure 167, 172
 Tyre pressure monitoring system 172
 Warning lamp 16, 36
 Tyre repair kit 178
 Tyres
 Inflation pressures 167, 172
 Tread wear indicators 168
 Tyre pressure monitoring system 172
 Tyre service life 167
- U**
- Universal transmitter 95
 Unleaded fuel 152
 Unlocking 43
 Central locking system 44
- V**
- Vehicle battery
 See Battery 162
 Vehicle data sticker 196
 Vehicle identification data 196
 Vehicle identification number 196
 Vehicles with automatic gearshift
 See R tronic 90
 Ventilation 75
 Voltmeter display 14
- Tyre pressure 167, 172
 Warning lamps 15
 Airbag 17
 Alternator 18
 Anti-lock brake system 19
 Audi magnetic ride 16
 Brake system 18
 Clutch overheating 38
 Electronic differential lock 19
 Electronic stabilisation program 16
 Emission control system 17
 Engine management (EPC) 16
 No R gear 38
 Rear spoiler 17
 Red symbols in central display 33
 Seat belt 18
 Selector lever defective 38
 Tyre pressure monitoring system 16, 36
 Yellow symbols in central display 33
 Warning triangle 178
 Washer fluid level low 37
 Washing 144
 Waxing 144
 Weights
 See Performance, weights and dimensions 198
 Wheel bolts 170
 Wheel imbalance 167
 Wheels 147, 166
 Rims 166
- Windows
 Cleaning 146
 Defrosting 78
 De-icing 146
 Windows (electric)
 See Electric windows 50
 Windscreen washer fluid 164
 Windscreen wipers 59
 Changing blades 62
 Service position 61
 Winter conditions
 Battery 162
 Care of vehicle 144
 Cooling system 159
 Defrost function 78
 De-icing windows 146
 Snow chains 171
 Tyres 170
 Windscreen washer 164
 Winter operation
 Seat heating (air conditioner) 80
 Winter tyres 170
 Wiper and washer system 59
 Wiper blades
 See Windscreen wipers 62