

FIND **NEW** ROADS™

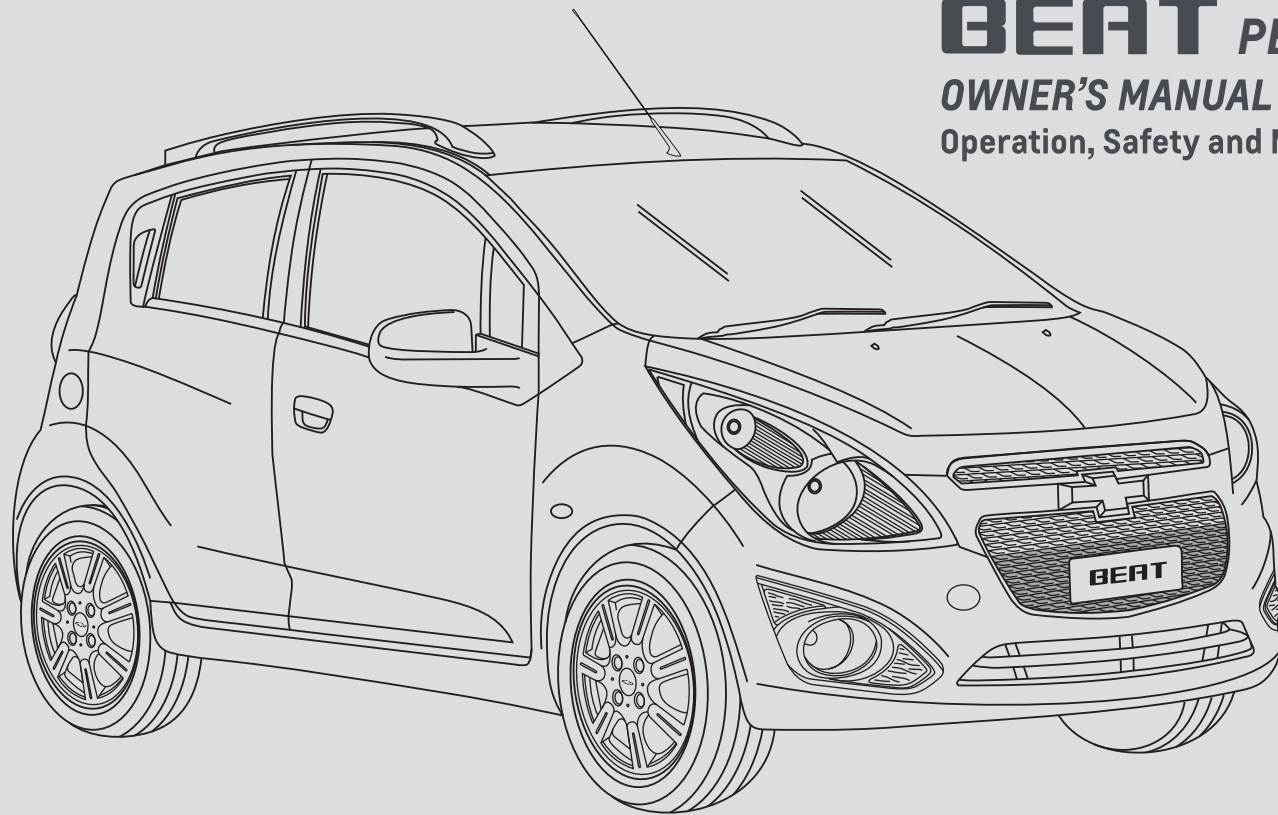

BEAT *PETROL*
OWNER'S MANUAL
Operation, Safety and Maintenance

VEHICLE RECORD SHEET

Model Name		Delivery Date								Tyre Make			
V.I.N.												Tyre Location	Batch Code
Engine No.										Key No.		Fr RH	
Registration No.										Regn. Date		Fr LH	
Transmission No.										Color, Code No.		Rr RH	
Battery Make										Battery Batchcode/SI.No.		Rr LH	
Owner's Name											Spare		
Address													
City											Pin Code		
Selling Dealer's Name													
Address													
										Pin Code		Selling Dealers Stamp	

Dear Customer,

Welcome to the Chevrolet family. We wish to thank you for choosing Chevrolet Beat.

It is our constant endeavor to provide you with products that offer excellent performance through out their ownership period. Which is why, in addition to offering great cars, we have also set up an extensive, and very well equipped network of retailers and authorized service centers across the country.

Naturally, these Chevrolet retailer know everything about your car and provides you with the best service possible. In fact, every retailer is equipped with the most advanced technology, technicians specially trained by us and genuine spares. Needless to say, they are also committed to ensure your complete satisfaction.

So, please contact a Chevrolet retailer for any servicing need and make sure that only genuine spares are used for your car.

This Manual will familiarize you with the operation and maintenance of your new vehicle. It will also provide you with important safety information. Please do read it carefully and follow the recommendations. In fact, the Manual is like a permanent part of your car. And it would go a long way in ensuring a safe and trouble-free operation for your car.

Should you have any query please feel free to call our 24 hr. Helpline at 1800 3000 8080 or email us at : gmi.cac@gm.com.

Happy Motoring

CONTENTS

Introduction	3
Initial drive information	5
Keys, doors and windows	15
Seats and restraints	23
Storage	45
Instruments and controls	51
Lighting	63
Infotainment system*	69
Climate control	79
Driving and operating	85
Vehicle care	97
Service and maintenance	133
Technical data	139
Service and warranty	143
Service network	175

INTRODUCTION

Introduction	3
Using this Manual	3
Danger, warnings and cautions	4

INTRODUCTION

Your vehicle is a designed combination of advanced technology, safety, environmental friendliness and economy.

This Owner's Manual provides you with all the necessary information to enable you to drive your vehicle safely and efficiently.

Make sure your passengers are aware of the possible risk of accident and injury which may result from improper use of the vehicle.

You must always comply with the specific laws and regulations of the country that you are in. These laws may differ from the information in this Owner's Manual.

When this Owner's Manual refers to a CHEVROLET retailer visit, we recommend your Chevrolet Service Partner.

All Chevrolet Service Partners provide first-class service at reasonable prices. Experienced mechanics trained by Chevrolet according to specific Chevrolet instructions.

The customer literature pack should always be kept ready to hand in the vehicle.

USING THIS MANUAL

- This Manual describes all options and features available for this model. **Certain descriptions, including those for display and menu functions, may not apply to your vehicle due to model variant, country specifications, special equipment or accessories.**
- This section will give you an initial overview.
- The table of contents at the beginning of this Manual and within each chapter shows where the information is located.
- The Owner's Manual uses the factory engine designations. The corresponding sales designations can be found in the chapter "Technical data".
- Directional data e.g. left or right, or front or back, always relate to the direction of travel.

4 Introduction

- The vehicle display screens may not support your specific language.
- Display messages and interior labelling are written in **bold** letters.

DANGER, WARNINGS AND CAUTIONS

Danger

Text marked **▲ Danger** provides information on risk of fatal injury. Disregarding this information may endanger life.

Warning

Text marked **▲ Warning** provides information on risk of accident or injury. Disregarding this information may lead to injury.

Caution

Text marked **Caution** provides information on possible damage to the vehicle. Disregarding this information may lead to vehicle damage.

Note

Text marked **Note** indicates a point to take into account when operating the vehicle. Failure to observe this may lead to incorrect operation.

* **or (Option)** : The asterisk and (Option) in this Manual signify an item of equipment that is not included on all vehicles. Such items include engine options, model variations specific to one country, and optional equipment.

All information, illustrations, and specifications in this Manual are based on the latest product information available at the time of publication.

General Motors India Pvt. Ltd. reserves the right to change specifications or designs at any time without notice and without incurring obligation.

This vehicle may not comply with the standards or regulations of other countries. Before attempting to register this vehicle in any other country, check all applicable regulations and make any necessary modifications.

This Manual describes the options and trims available at the time of publication. Some of the items covered may not apply to your vehicle. Contact your CHEVROLET retailer for information on option and trim availability.

Non-General Motors India Pvt. Ltd. genuine parts and accessories have not been examined or approved by General Motors India Pvt. Ltd. We can certify neither the suitability nor the safety of Non-General Motors India Pvt. Ltd. genuine parts and accessories and are not liable for damage caused by their use.

Warning : Tampering of wiring harness or fitment of non genuine accessories in your vehicle may lead to short circuit resulting in fire.

We wish you many hours of pleasurable driving **Chevrolet**.

INITIAL DRIVE INFORMATION

Seat adjustment	5
Safety belts	6
Mirror adjustment	7
Steering wheel adjustment*	7
Instrument panel overview	8
Exterior lighting	9
Horn	10
Washer and wiper systems	11
Climate control	11
Transmission	12
Getting started.....	12
Parking	13

SEAT ADJUSTMENT

Seat Positioning



Pull handle, slide seat, release handle.
See *Seat adjustment* on page 33.
See *Seat positioning* on page 33.

Seat Backrest

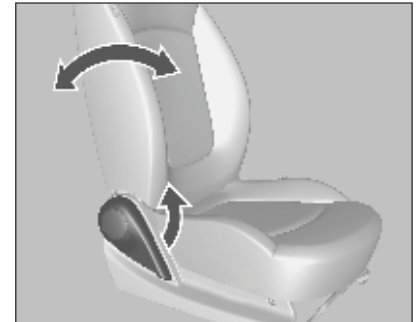

Pull lever, adjust inclination and release lever. Allow the seat to engage audibly.
Do not lean on seat backrest when adjusting.

Head Restraint Adjustment

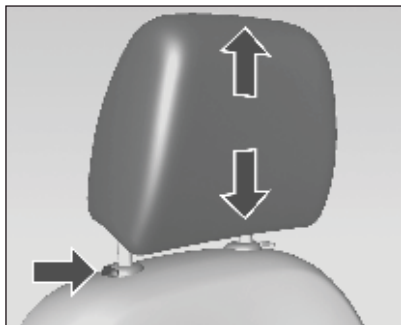

Pull the head restraint upwards.

To move down press the release button and push the head restraint downwards.

To pull out a head restraint completely, press the release button and take out the head restraint.

See *Head restraints* on page 31.

Seat Height Adjustment * (Driver's Seat)

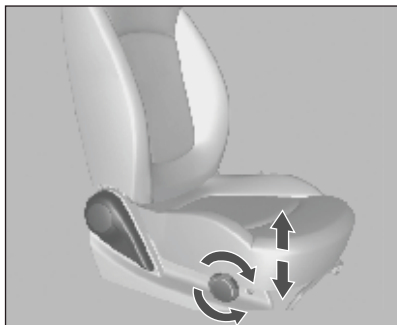

To adjust the height of the entire seat cushion, rotate the knob.

Rotate the knob clock-wise to move up and anti-clock wise to move down.

SAFETY BELTS



Withdraw belt from reel, guide it untwisted across the body and engage the latch plate in the buckle.

To release the belt, press the red button on the belt buckle.

See *Safety belts* on page 35.

See *Airbag system* on page 35.

See *Seat positioning* on page 33.

MIRROR ADJUSTMENT

Interior Mirror

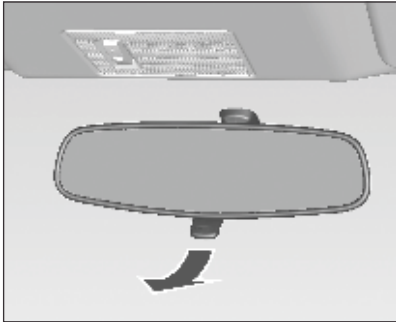

To adjust the inside rearview mirror, hold the rearview mirror in the center and move it to view the area behind the vehicle.

To reduce dazzle, adjust the lever on the underside of the mirror housing.

See *Manual rear view mirror* on page 19.

Exterior Mirrors

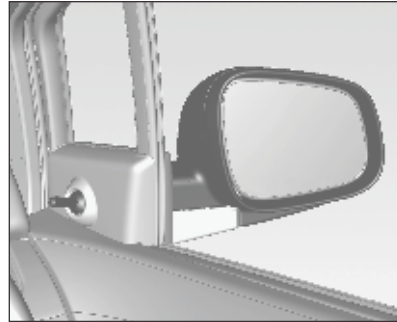

Simply move the adjusting lever in the desired direction to adjust the mirror angles.

See *Convex mirrors* on page 18.

See *Folding mirrors* on page 18.

STEERING WHEEL ADJUSTMENT*



Unlock lever, adjust steering wheel, then engage lever and ensure it is fully locked. Do not adjust steering wheel unless vehicle is stationary.

See *Airbag system* on page 35.

See *Ignition switch positions* on page 88.

8 Initial Drive Information

INSTRUMENT PANEL OVERVIEW

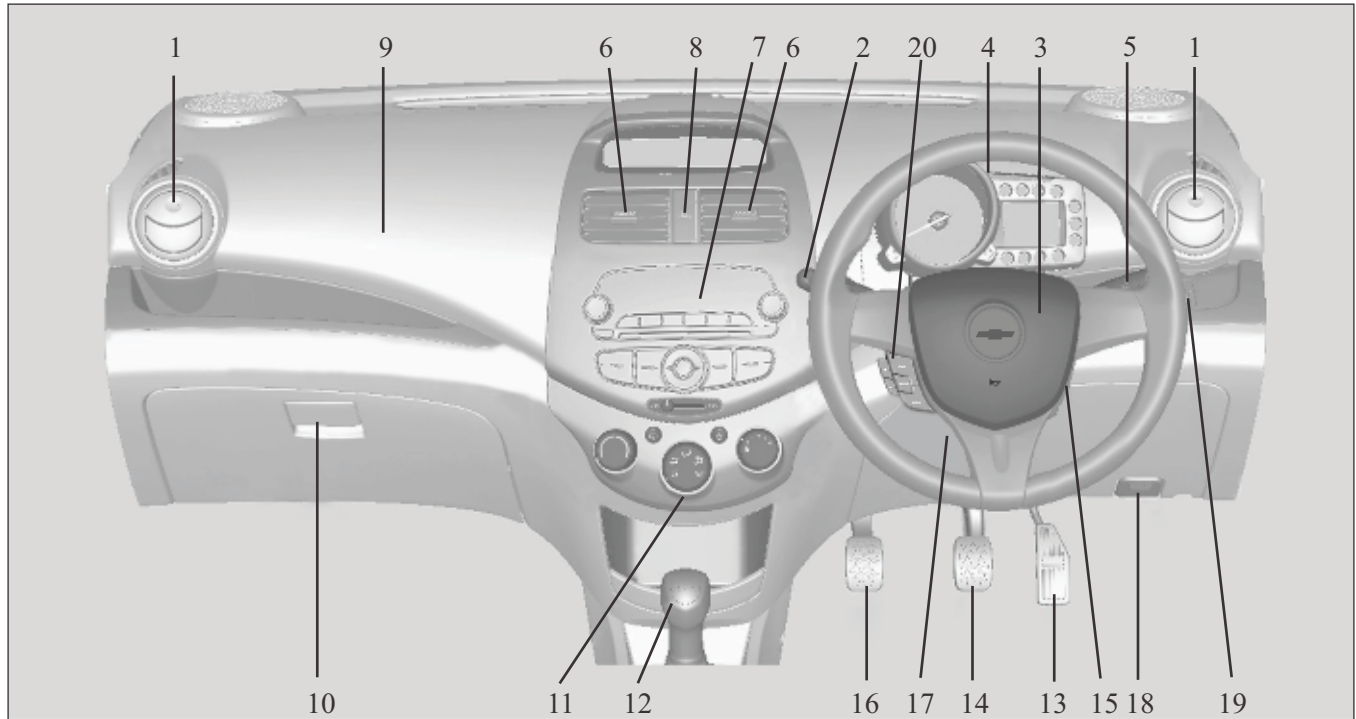

1. Side air vents
2. Wiper and washer lever
3. Horn, Driver airbag
4. Cluster
5. Exterior lamp lever
6. Center air vents
7. Infotainment system
8. Hazard warning switch
9. Passenger airbag
10. Glove box
11. Climate control system
12. Shift lever
13. Accelerator pedal
14. Brake pedal
15. Ignition switch
16. Clutch pedal
17. Steering wheel adjustment
18. Hood release lever
19. Headlamp range adjustment
20. Steering wheel audio control switch

EXTERIOR LIGHTING

Exterior Lamp Controls

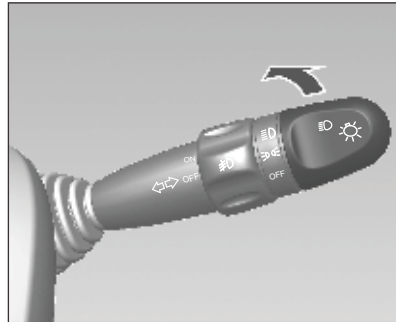

Turn light switch.

OFF : All the lamps are off.

☞ : The parking lamps, tail lamps, number plate lamps and instrument panel lamps are illuminated.

☞D : The low-beam headlamps and all of the above lamps are illuminated.

See *Exterior lamp controls* on page 63.

Headlamp High/Low-Beam Change

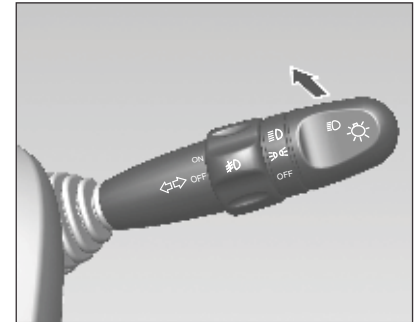

To switch from low to high beam, push lever.

To switch to low beam, pull lever.

See *Headlamp high/low-beam changer* on page 64.

See *Flash-to-pass* on page 64.

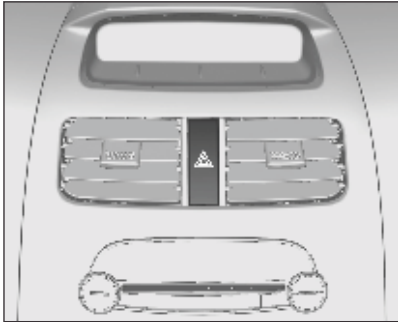

Hazard Warning Flashers

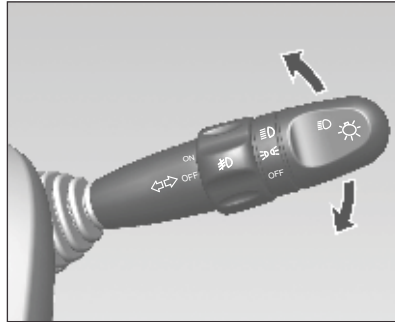

Operated with the  button.
See *Hazard warning flashers* on page 65.

Turn And Lane-Change Signals



Lever up  = Left indicator
Lever down  = Right indicator
See *Turn and lane-change signals* on page 66

HORN



Press the  switch on the steering wheel pad to sound the horn.

WASHER AND WIPER SYSTEMS

Windshield Wipers

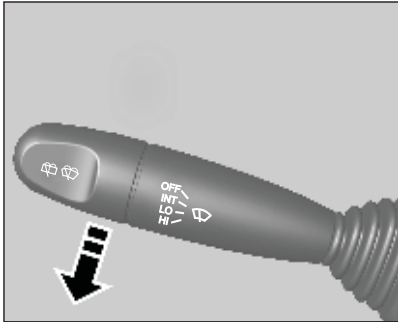

- OFF** : System off.
- INT** : Intermittent operation.
- LO** : Continuous wipe, slow speed.
- HI** : Continuous wipe, fast speed.

For a single wipe when the windshield wipers are off, lightly move the lever towards the INT position and release it.

See *Windshield wiper/washer* on page 52.

Windshield Washer

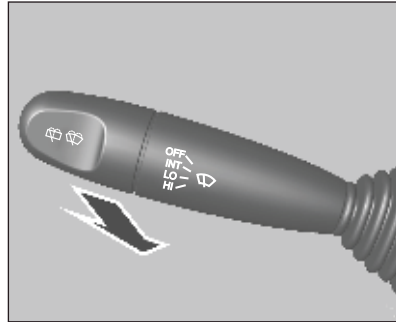

Pull lever.

See "*Windshield washer*" under *Windshield wiper/washer* on page 53.

See *Washer fluid* on page 106.

CLIMATE CONTROL

Heated Rear Window*



Heating is operated by pressing the  button.

See *Heated rear window / Windshield wiper de-icer* on page 21.

Demisting And Defrosting The Windows



See "*Demisting windshield*" under *Air conditioning system* on page 80.

TRANSMISSION

Manual Transmission

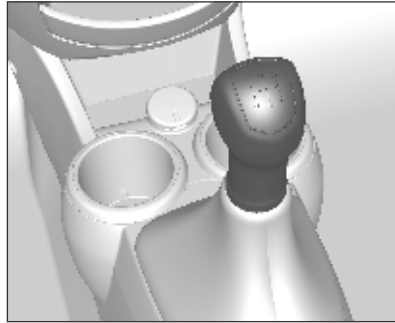

Reverse: With the vehicle stationary, depress the clutch pedal and engage the gear.

If the gear does not engage, set the lever to neutral, release the clutch pedal and depress again; then repeat gear selection.

See *Manual transmission* on page 89.

GETTING STARTED

Check Before Starting Off

- Tire pressure and condition.
- Engine oil level and fluid levels.
- All windows, mirrors, exterior lighting and number plates are free from dirt, snow and ice and are operational.
- Proper position of seats, seat belts and mirrors.
- Check brake function at low speed, particularly if the brakes are wet.

Starting Engine With The Ignition Switch

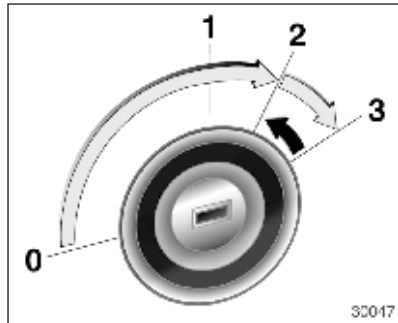

- Turn key to position **1**, move the steering wheel slightly to release the steering wheel lock.
- Manual transmission: Operate clutch.
- Do not press accelerator pedal.
- Turn key to position **3** depressing the clutch pedal and foot brake then release when engine is running.

Before restarting or to switch off the engine, turn key back to **0** or **1**.

PARKING

- Do not park the vehicle on an easily flammable surface. The high temperature of the exhaust system could ignite the surface.
- Always apply parking brake without pressing release button. Apply as firmly as possible on downhill or uphill slopes. Depress the footbrake at the same time to reduce operating force.
- Switch off the engine and ignition. Turn the steering wheel until the steering wheel lock engages.
- If the vehicle is on a level surface or uphill slope, engage first gear before switching off the ignition. On an uphill slope, turn the front wheels away from the kerb. If the vehicle is on a downhill slope, engage reverse gear before switching off the ignition. Turn the front wheels towards the kerb.
- Close windows.
- Lock the vehicle.

See *Keys* on page 15.

Note

The engine cooling fan may continue to run after the engine is shut down.

KEYS, DOORS AND WINDOWS

Keys, locks	15
Doors	17
Exterior mirrors	18
Interior mirror	19
Windows	20
Sun visors	22
Assist handles	22

KEYS, LOCKS

Keys

Replacement keys

The key number is specified on a detachable tag.

The key number must be quoted when ordering replacement keys.

Two keys are provided with your new vehicle.

Keep one of the two keys as a spare.

See "Locks" under *Exterior care* on page 130.

Warning

Do not leave the key in the vehicle.

- Lock the vehicle.
- Take the key with you.

Note

In case of loss, replacement keys are available with your CHEVROLET retailer.

Warning

Leaving children in a vehicle with the ignition key is dangerous for many reasons. Children or others could be badly injured or even killed. They could operate the power windows or other controls or even make the vehicle move.

The windows will function with the key in the ignition and children could be seriously injured or killed if caught in the path of a closing window. Do not leave the keys in a vehicle with children.

Central Locking System*

You can activate the central door locking system from the driver's door.

This system allows you to lock and unlock all the doors from the driver's door, using either the key or the door lock knob (from inside).

If the driver's door is not closed properly, the central locking system will not work.

Fault in central locking system

Unlocking

Manually unlock the driver's door by turning the key in the lock. The other doors can be opened by using the interior handle.

Locking

Push inside locking knob of all doors except driver's door. Then close the driver's door and lock it from the outside with the key.

Warning

Do not lock the vehicle if anyone is to be left inside the vehicle.

Never leave children or pets unattended in your vehicle. The temperature inside the vehicle can increase more rapidly and reach much higher levels than the temperature outside.

This can result in serious injury or death.

Safety Locks



Caution

Do not pull the inside door handle while the child security door lock is set to LOCK position. Doing so can damage the inside door handle.

Warning

Use the child security door locks whenever children are occupying the rear seats.

To operate the child security door lock, move the lever up to the lock position.

To open a rear door when the child security door lock is activated, unlock the door from inside and open the door from outside.

To cancel the child security door lock, move the lever down to the unlock position.

Note

Each rear door has its individual lock. The child safety locks for the rear doors must be individually, manually activated.

DOORS

Tailgate Opening

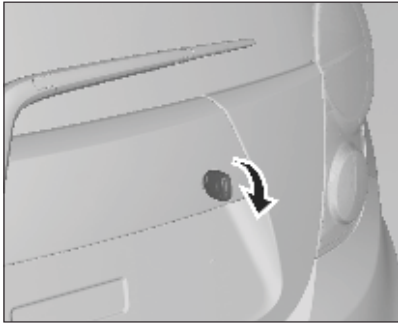

To open the tailgate, insert the key into the key slot and turn it clockwise.
Lift the tailgate.



You can also open the tailgate by pulling up the tailgate release lever located near the driver's seat.

⚠ Warning

Do not drive with the tailgate open or ajar, e.g. when transporting bulky objects, since toxic exhaust gases could enter the vehicle.

Caution

Before opening the tailgate check overhead obstructions, such as a garage door, to avoid damage of the tailgate. Always check the moving area above and behind the tailgate.

Note

The installation of certain heavy accessories onto the tailgate may affect its ability to remain open.

Closing

To close tailgate, push it down so it latches securely. It locks automatically.

Make sure your hands and any other body parts, as well as those of other persons are completely away from the tailgate closure area.

EXTERIOR MIRRORS

Convex Mirrors

The convex exterior mirror reduces blind spots. The shape of the mirror makes objects appear smaller, which will affect the ability to estimate distances.

Both outside mirrors are convex and is labelled with a notice that reads as follows:

**OBJECTS IN MIRROR ARE
CLOSER THAN THEY APPEAR**

Manual Mirrors

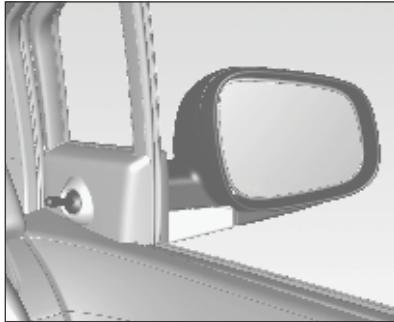

Adjust the outside rearview mirrors so you can see each side of your vehicle, as well as each side of the road behind you.

Simply move the adjusting lever in the desired direction to adjust the mirror angles.

Folding Mirrors

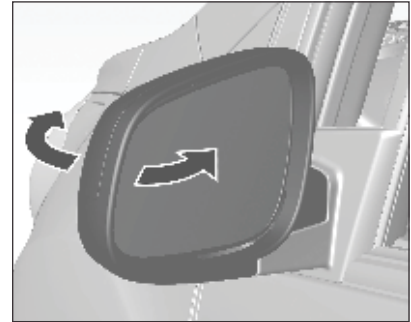

For pedestrian safety, the exterior mirrors will swing out of their normal mounting position if they are struck with sufficient force. Reposition the mirror by applying slight pressure to the mirror housing.

▲ Warning

Always keep your mirrors properly adjusted, and use them while driving to increase your visibility of objects and other vehicles around you. Do not drive while either outside rearview mirror is folded back.

INTERIOR MIRROR

Manual Rearview Mirror

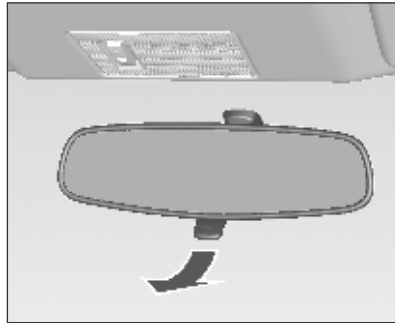

To adjust the inside rearview mirror, hold the rearview mirror in the center and move it to view the area behind the vehicle.

To reduce dazzle, adjust the lever on the underside of the mirror housing.

▲ Warning

Your view through the mirror may lose some clarity when it is adjusted for night vision.

Take special care while using your inside rearview mirror when it is adjusted for night vision.

Failure to ensure a clear rear view while driving may result in a collision causing damage to your vehicle or other property, and/or personal injury.

WINDOWS

Manual Windows



To raise or lower the windows, turn the window regulator handle on the door panel.

Be sure there is no object in the opening before closing the windows.

Note

The rear windows cannot be fully opened.

Power Windows*

Warning

Take care when operating the power windows. There is risk of injury, particularly to children.

If there are children on the rear seat, switch on the child safety system for the power windows.

Keep a close watch on the windows when closing them.

Ensure that nothing becomes trapped in them as they move.

Warning

Do not operate the power window switch with no purpose.



Power windows can be operated with ignition on.

Operate the switch for the respective window by pushing to open or pulling to close.

Operation

You may operate the power windows when the ignition switch is ON by using the power window switches on each door panel.

To raise the window, lift up the switch.

To lower the window, press down the switch.

Release the switch when the window reaches the desired position.

Note

The rear windows cannot be fully opened.

Warning

Body parts outside vehicle can be struck by passing objects. Please keep all parts of the body inside vehicle.

Children can operate and become entrapped in power windows.

Do not leave your keys or unattended children in your car.

Serious injury or death can occur from misuse of power windows.

Child Safety System For Rear Windows*



The power window lockout button  can lock out the rear window switches. The rear windows can only be operated by the front switches after this button is locked.

Caution

Children could operate the power windows and become trapped by the windows, resulting in serious injuries.

Use the power window lockout button  when children are traveling in the rear seats.

Heated Rear Window* / Windshield Wiper De-icer*



Operated by pressing the  button.

Heating works with the ignition ON/ engine running and is switched off automatically after a few minutes or by pressing the button again.

Caution

Do not use sharp instruments or abrasive window cleaners on your vehicle's rear window.
Do not scratch or damage the defroster wires when you clean or work around the rear window.

SUN VISORS

The sun visors can be folded down or swivelled to the side to prevent dazzling.

If the sun visors have integral mirrors, the mirror covers* should be closed when driving.

Warning

Do not place the sun visor in such a manner that it obscures visibility of the roadway, traffic or other objects.

ASSIST HANDLES

Your vehicle has assist handles above the front seat passenger door & the rear doors. The handle above the rear doors include a coat hook.

Passengers can use the grips for assistance in entering / exiting the vehicle, or for hand-hold during the vehicle in motion.

Caution

Hanging items on the assist handles can obstruct the driver's view. Do not hang anything on the assist handle unless the handle is equipped with a coat hook.

Obstructing the driver's view can lead to an accident resulting in personal injuries and damage to your vehicle or other property.

SEATS AND RESTRAINTS

Always wear your safety belts	23
Front seat occupants	28
Rear seat occupants	28
Three-point safety belts	28
Center rear lap belt	30
Pregnant women and safety belts ...	31
Head restraints	31
Front seats	32
Safety belts	35
Air bag system*	35
Child restraints*	44

ALWAYS WEAR YOUR SAFETY BELTS

Occupant protection has been the focus of much private and public research and development for many years. The seat belts are incorporated into the vehicle solely for the protection of the occupants. The safety belts can protect you and your passengers only if they are used.

The safety belt information included here is intended for vehicle occupants of adult size and for older children who have outgrown booster seats.

Be sure that if children are too small to be well restrained by the safety belt system, that they are secured in an appropriate child restraint.



Why Wear Safety Belts?

Safety belts are helpful for several distinct reasons:

- 1) Safety belts attach the occupants to the vehicle so that they will not be ejected during an accident.
- 2) Safety belts attach the occupants to the vehicle so that they can use the space between their pre-crash seating position and the front of the vehicle to slow down to a stop more gradually, as their safety belts stretch and the front end of the vehicle absorbs the energy of the crash by crumpling.
- 3) Safety belts keep the driver in his seat, so that the driver might have a chance to regain control in certain accident situations.
- 4) Safety belts keep occupants from being catapulted into and injuring the driver and other occupants.

Warning

- Safety belts have been shown to be the single most effective protection against injury or death in an accident!
- As the owner and driver of your vehicle, you must make certain that each occupant is properly wearing the safety belt provided at the seating position.
- Pregnant women, injured, and physically impaired persons should also wear safety belts. Like all other occupants, they are more likely to suffer serious injury or death, if they do not do so.
- The best way to protect the foetus is to protect the mother.

Warning

- Why safety belts work, how to wear them, and how to adjust your seat position properly, is explained in this section. Read all of the information provided and always observe these instructions and warnings in order to gain the full benefit of these safety systems.

How Safety Belts Work?

Safety belts cannot work unless they are worn and worn properly.

Vehicle occupants are injured if the forces applied to the body's structures are greater than the body can tolerate without being injured. If a person's body is stopped abruptly, the forces applied to the body will be high, whereas if the body is slowed down gradually over some distance, the forces will be much lower. Thus, in order to protect an occupant from injury in a crash, the idea is to give the person as much time and distance as possible in coming to a stop.

Imagine a person running at 15 miles per hour (25 km/h) head first into a concrete wall. Imagine a second person running at 15 miles per hour (25 km/h) into a wall covered by a 3-foot (90 cm) thick deformable cushion. In the first instance the person could be seriously injured or even killed. In the second, the runner could expect to walk away

uninjured. Why? In the first instance, the body hit the non-yielding concrete surface and stopped immediately. All of the energy the sprinter built up was absorbed by the structures of the body, not by the non-yielding concrete surface. In the second example, the body had exactly the same amount of energy that had to be absorbed as in the first example, but it continued to move into the padding, giving the body additional time and distance to slow down to a complete stop as the padding absorbed the sprinter's energy by deforming.

If a car crashes into a concrete wall at 30 miles per hour (50 km/h), the front bumper of the car stops immediately, but the passenger compartment stops more gradually as the front structure of the vehicle crumples. The belted occupant is held to the seat and gains the advantage of the cushion provided by the crumpling of the front of the vehicle and the stretching of the safety belt webbing. That belted occupant's body slows down from 30 mph

(50 km/h) to zero over a distance of 90-120 cm (3-4 feet). That belted occupant also remains properly positioned so that, if the air bag (if provided) deploys in a frontal collision, the occupant might never strike any rigid structures in the vehicle. The unbelted occupant receives no such benefit. The unbelted person is not attached to the vehicle and so that person continues to travel at the vehicle's pre-crash speed of 30 miles per hour (50 km/h) until striking a hard object at approximately 30 miles per hour (50 km/h) and stopping abruptly. Even in a frontal collision in which the air bag (if provided) deploys, the unbelted front seat occupant remains at greater risk of serious injury or death than the properly restrained front seat occupant.

 **Warning**

SAFETY BELTS PROTECT

Accident statistics show that drivers and passengers properly wearing safety belts have a lower risk of being injured and a higher chance of surviving an accident. For this reason, wearing a safety belt is legally required in most countries.

WEARING THE SAFETY BELT

Each front seat and each outboard rear seat of your CHEVROLET vehicle is equipped with a three-point safety belt system that is anchored at three locations. All front and rear seat belts are stored and locked by a retractor mechanism. When set in its normal emergency locking mode, the three-point safety belt requires no length adjustment and allows freedom of movement when the vehicle moves at constant speeds.

(Continued)

Warning

However in a sudden or strong stop, or during heavy acceleration or deceleration, the safety belt will lock automatically to restrain the body.

In order to gain the full benefit of a safety belt, you must wear it correctly and position yourself correctly within your seat, as follows:

- Seatback upright (not reclined, to prevent you from “submarining” or slipping out from under the safety belt, and injuring vulnerable body parts in a crash).
- Occupant sitting upright (not slouched, to properly position the lap and shoulder portions of the safety belt for maximum restraint and minimum injury to soft and vulnerable parts of your body in a crash).

(Continued)

Warning

- Safety belt latch plate and buckle securely fastened with a “click” (if the safety belt is not securely latched, it cannot provide any protection; pull on the belt to make sure it is secure).
- Lap portion of safety belt snug and low on hips and bony pelvis (not abdomen where the restraining belt could cause serious injury in a crash – THIS IS PARTICULARLY IMPORTANT FOR PREGNANT WOMEN).
- Shoulder portion of the safety belts over your outside shoulder and snug against the chest (not under an arm, around your neck, over an inside shoulder or behind your back, and not loose with slack allowing excessive forward movement and injury in a crash).

(Continued)

Warning

- Only one occupant per one safety belt (do not allow more than one person in a safety belt; multiple people in a single safety belt can exceed the capacity of the safety belts and people sharing a safety belt can cause crushing and other injuries to each other in a crash).
- Children in secure child seats (in a crash the forces are too great for an adult to hold onto a child and the adult will crush the child if they share the same safety belt).
- No unbelted occupants (occupants not wearing a safety belt are an injury threat to themselves and to other occupants in the vehicle because in a crash they become a free-flying body that will strike other persons in their path).

(Continued)

⚠ Warning

- No twisted safety belts (twisted safety belts will not move freely and restrain properly and can cut into the occupants rather than spread the force, thus increasing the risk of injury and death).
- Lock doors (unlocked doors increase the risk of injury and death from external impacts and ejection in a crash).

⚠ Warning

- Make periodic checks (while riding in the vehicle, check from time to time to be sure that the lap portion of the belt is snugly across the hips and has not ridden up around the waist and that the shoulder portion is midway over the shoulder and across the chest; properly positioned belts allow the stronger structures of the hips and shoulders to absorb the forces of the belt against the body, while improperly positioned belts may cause neck injury or injury to the vulnerable organs in the abdominal area).
- No hard or breakable objects, between safety belts and body parts (objects such as pens, glasses, etc. in the occupant's pocket or on the cloth can cause injury in the event of a collision).

(Continued)

⚠ Warning

- Improper use of a safety belt can cause serious injury. Do not modify the safety belt. Do not add any device which would affect the operation of the safety belt.
- Before you close the door, make sure the safety belt is out of the way. Otherwise, the belt and/or the vehicle body could be damaged.

⚠ Warning

If the safety belt goes over an armrest (if so equipped), lap portion of the safety belt could force the occupant's abdomen, not the bony pelvis, in a collision.

- Be sure that the safety belt goes under the armrest.

Failure to follow this can result in injuries or even death in case of a collision.

FRONT SEAT OCCUPANTS

Each front seat is equipped with adjustable seat and seatback with height-adjustable head restraint and three point lap-and-shoulder safety belts.

REAR SEAT OCCUPANTS

The rear seat is equipped with two outboard seating positions featuring three-point lap-and-shoulder safety belts and a center seat equipped with a lap safety belt.

THREE-POINT SAFETY BELTS

To help reduce the risk of personal injury in collisions or sudden manoeuvres, your CHEVROLET vehicle is equipped with three-point safety belts. The two front seats and the two outboard rear seating positions are each equipped with three-point safety belts. These safety belts are each anchored in three locations to restrain passengers who are properly positioned and wearing the safety belt.

A three-point safety belt set in the ELR / WLR (Emergency Locking Retractor / Webbing Locking Retractor) mode requires no length adjustment and allows the freedom of body movement when the vehicle moves at a constant speed.

However, in the event of a sudden or strong stop, or during heavy acceleration or deceleration, the safety belt will lock automatically to restrain the body.



Always fasten your safety belts correctly:

1. Close and lock the doors.
2. Make sure seatback is upright.
3. Pick up the safety belt latch plate and use it to pull the belt across your body. Make sure the belt is not twisted. If the safety belt locks as you are pulling it out, allow it to rewind into the retractor. Pull the safety belt out again to a comfortable and secure length.

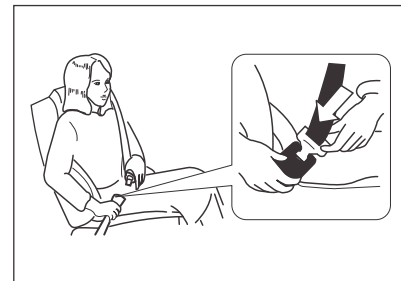

4. Position the shoulder belt midway over the shoulder and across the chest. Never place the shoulder belt across the neck. This assures that in the case of a collision, the belt applies force to the shoulder bones and keeps the impact away from ribs or neck, helping to avoid serious internal injuries.
5. Wear the lap belt low and snug on the hips, not the waist. This assures that in the case of a collision, the belt applies force to the pelvic bones and not the abdomen, helping to avoid serious injuries.

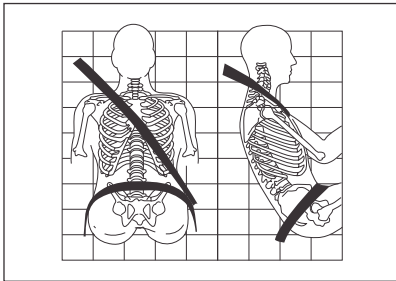

6. Push the latch plate firmly into the buckle until the mechanism clicks. Make sure you are using the proper buckle. Be sure to position the release button on the buckle so you can unbuckle the safety belt quickly if necessary.
7. Pull up on the latch plate to make sure it is secure.

To remove the safety belt, press the release button on the buckle. The belt will retract automatically. Guide the safety belt as it retracts to prevent the latch plate from damaging interior surfaces or injuring occupants.

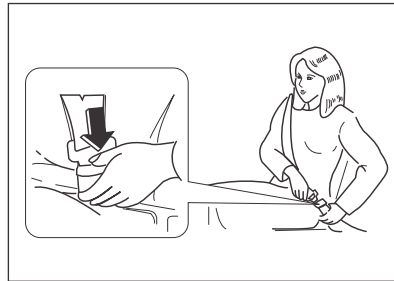

Maintain your safety belts:

1. Periodically inspect all safety belts, related parts, and assemblies. Have these replaced by your CHEVROLET retailer if any safety belts, assemblies or related parts are damaged.
2. You must replace any safety belt or related part that has been stretched or damaged in an accident, even if the stretching or damage is not obvious or visible. Stretched belts and damaged parts do not perform effectively. Replacement of safety belts must be with new belts only.
3. Chevrolet recommends replacing the entire safety belt assembly after your vehicle has been in a collision. If your CHEVROLET retailer finds that no safety belt damage has occurred and that everything is in proper working order, you need not make any replacement.
4. It is dangerous to operate your vehicle with damaged safety belts or other parts.

Safety Belt Care

Keep belts clean and dry.

Warning

Do not bleach or dye safety belts. It may severely weaken them. In a crash, they might not be able to provide adequate protection. Clean safety belts only with mild soap and lukewarm water.

Warning

A crash can damage the safety belt system in the vehicle. A damaged safety belt system may not properly protect the person using it, resulting in serious injury or even death in a crash. To help make sure the safety belt systems are working properly after a crash, have them inspected and any necessary replacements made as soon as possible.

CENTER REAR LAP BELT

To fasten the center rear lap belt:

1. Hold the metal latch plate 90 degrees to the belt and pull belt low across hips.
2. Insert the latch plate into the buckle.

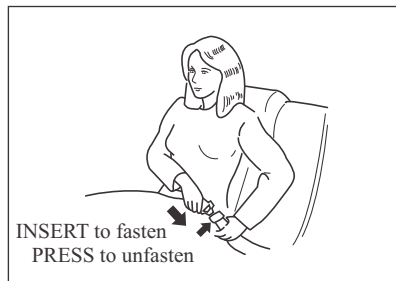

3. Pull free end of belt away from latch plate to tighten belt.
4. Pull on belt clip to take up slack.

To remove the lap belt, press the release button on the buckle.

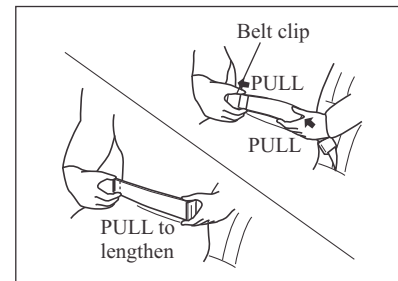

⚠ Warning

- After a collision, inspect all safety belts and related parts for fraying or other damage. Ask your CHEVROLET retailer to replace any damaged parts.
- It is dangerous to operate your vehicle with damaged safety belts or other parts.

Failure to make appropriate repairs may result in additional damage to your vehicle or personal injuries.

PREGNANT WOMEN AND SAFETY BELTS

Safety belts work for everyone, including pregnant women.

Like all occupants, pregnant women are more likely to be seriously injured if they do not wear safety belts. In addition, when a safety belt is worn properly, it is more likely that the unborn child will be safe in a crash.

To provide maximum protection, a pregnant woman should wear a three-point safety belt. She should wear the lap portion of the belt as low as possible across the pelvis to prevent pressure on the abdomen throughout her pregnancy.

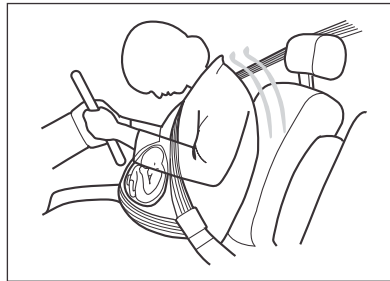

HEAD RESTRAINTS

Position

⚠ Warning

Only drive with the head restraint set to the proper position.

Removed or improperly adjusted head restraints can result in serious head and neck injuries in case of a collision.

Make sure that the head restraints are properly adjusted before driving.



The middle of the head restraint should be at eye level. If this is not possible for extremely tall persons, set to highest position, and set to lowest position for short people.

Head Restraints On Front Seats

Height adjustment

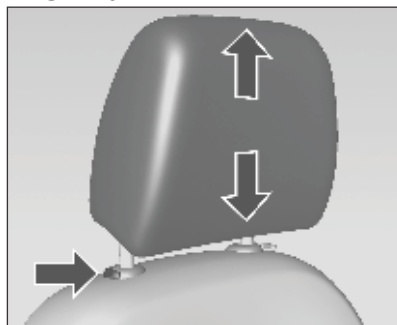

Pull the head restraint upwards.

To move down press the release button and push the head restraint downwards.

Removing

Press the release button and pull up the head restraint.

FRONT SEATS

Seat Position

Warning

Only drive with the seat correctly adjusted.



- Sit with your buttocks as far back against the backrest as possible. Adjust the distance between the seat and the pedals so that your legs are slightly angled when tromping the pedals. Slide the passenger seat as far back as possible.

- Sit with your shoulders as far back against the backrest as possible. Set the backrest angle so that you can easily reach the steering wheel with your arms slightly bent. Maintain contact between your shoulders and the backrest when turning the steering wheel. Do not tilt the backrest too far back. We recommend a maximum angle of approx. 25°.
- Adjust the steering wheel. See *Steering wheel adjustment* on page 51.
- Set the seat at the desired position to have a clear field of vision on all sides and on all display instruments. There should be at least one hand of clearance between your head and the headlining. Your thighs should rest lightly on the seat without pressing into it.
- Adjust the head restraint. See *Head restraints* on page 31.

Seat Adjustment

⚠ Danger

Do not sit nearer than 25 cm from the steering wheel, to permit safe airbag deployment.

⚠ Warning

Never adjust driver's seat while driving. Driver could lose control of the vehicle and it results in injury or property damage.

Seat positioning

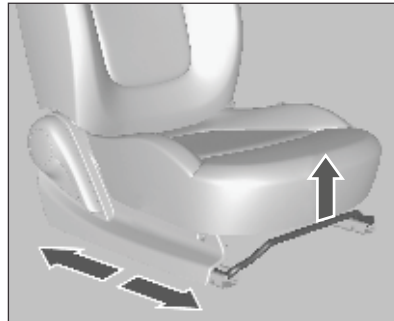

Pull handle, slide seat, release handle.

Seat backrest

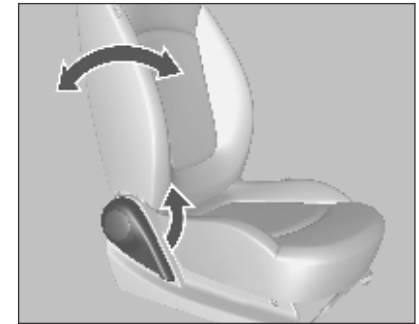

Pull lever, adjust inclination and release lever. Allow the seat to engage audibly.

After the adjustment, lean back against the backrest to make sure that the seatback has been locked in an appropriate position.

Do not lean on seat backrest when adjusting.

⚠ Warning

You can lose control of the vehicle if you try to adjust a driver seat while the vehicle is moving.

Adjust the driver seat only when the vehicle is not moving.

⚠ Warning

If either seatback is not locked, it could move forward in a sudden stop or crash. That could cause injury to the person sitting there. Always push and pull on the seatbacks to be sure they are locked.

⚠ Warning

Things you put on this seatback can strike and injure people in a sudden stop or turn, or in a crash. Remove or secure all items before driving.

⚠ Warning

Sitting in a reclined position when the vehicle is in motion can be dangerous. Even when buckled up, the safety belts cannot do their job.

The shoulder belt will not be against your body. Instead, it will be in front of you. In a crash, you could go into it, receiving neck or other injuries.

The lap belt could go up over your abdomen. The belt forces would be there, not at your pelvic bones. This could cause serious internal injuries.

For proper protection when the vehicle is in motion, have the seatback upright. Then sit well back in the seat and wear the safety belt properly.

Seat Height Adjustment * (Driver's Seat)



To adjust the height of the entire seat cushion, rotate the knob.

Rotate the knob clock-wise to move up and anti-clock wise to move down.

SAFETY BELTS



The belts are locked during heavy acceleration or deceleration of the vehicle for the safety of the occupants.

Warning

Fasten safety belt before each trip.

In the event of an accident, people not wearing safety belts endanger their fellow occupants and themselves.

Safety belts are only designed for use by one person at a time. They are not suitable for people younger than 12 years of age or smaller than 150 cm (5 ft).

Periodically check all parts of the belt system for damage and proper functionality.

Have damaged components replaced. After an accident, have the belts replaced by a CHEVROLET retailer.

Note

Make sure that the belts are not damaged by shoes or sharp-edged objects. Prevent dirt from getting into the belt retractors.

Safety belt reminder . See *Safety belt reminder* on page 59.

AIR BAG SYSTEM*

Your vehicle is equipped with an air bag Supplemental Restraint System (SRS) designed to protect properly seated and restrained front seat occupants. Both the driver and front passenger seating positions are equipped with driver and passenger air bags in addition to three-point safety belts and other safety features. Each air bag is specially packed in a module, from which the air bag is designed to inflate and deploy at extremely high speed and force in the event your vehicle is involved in certain types of collisions which pose a high risk of serious injury or death to the driver and passengers.

⚠ Warning

If handled improperly the airbag systems can be triggered in an explosive manner.

The driver should sit back as far as possible while still maintaining control of the vehicle. If you are sitting too close to the airbag, it can cause death or serious injury when it inflates.

For maximum safety protection in all types of crashes, all occupants including the driver should always wear their safety belts to minimize the risk of severe injury or death in the event of a crash. Do not sit or lean unnecessarily close to the airbag while the vehicle is in motion.

The air bag may cause facial or body scratch, injury by broken glasses or getting a burn by explosion while air bag is deployed.

⚠ Warning

The airbag system control electronics are located in the center console area. Do not put any magnetic objects in this area.

Do not stick anything on the airbag covers and do not cover them with other materials.

Each airbag is triggered only once. Have deployed airbags replaced by a CHEVROLET retailer.

Do not make any modifications to the airbag system as this will invalidate the vehicle type approval.

In the event of airbag deployment have the steering wheel, the instrument panel, all paneling parts, the door seals, the handles and the seats removed by a CHEVROLET retailer.

When an air bag deploys, there may be a loud noise and smoke. These conditions are normal and are not dangerous but in case it may irritate skin of the passenger. If the irritation is continued, contact a doctor.

⚠ Danger

Never allow children or infants and pregnant women and the old and the weak sit in the front passenger seats fitted with airbags.

Furthermore, do not drive with a baby seat fitted thereon. In case of an accident, the impact from the inflated airbag can cause facial injury or death.

Caution

If the vehicle is impacted by bumps or objects on unpaved roads or sidewalks, the air bag may inflate. Drive slowly on the surfaces not designed for vehicle traffic to prevent unintended air bag deployment.

Control indicator  for airbag systems. See *Airbag warning light* on page 59.

Front Airbag System

The front airbag system consists of one airbag in the steering wheel and one in the instrument panel on the front passenger side. These can be identified by the word AIRBAG.

The front airbag system is triggered in the event of an accident of a certain severity in the depicted area. The ignition must be on.

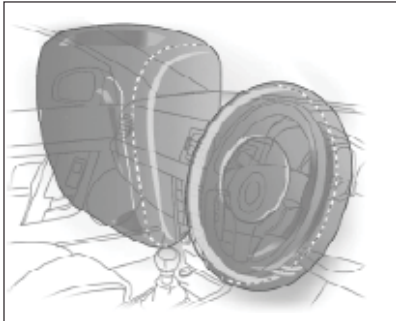

The forward movement of the front seat occupants is retarded, thereby considerably reducing the risk of injury to the upper body and head.

⚠ Warning

Air bags are only a supplemental restraint, and are most effective in combination with safety belts.

All occupants, including the driver, should always wear their safety belts, whether or not an air bag is also provided at their seating position, to minimize the risk of severe injury or death in the event of a crash.

- Air bags do not deploy in side or rear collisions. Occupants not wearing their safety belts will not be protected by any restraint system, resulting in severe injuries or death in these types of collisions.
- Occupants who are not properly wearing their safety belts may be thrown forward by braking before impact, placing their bodies near or against the air bag modules. This can cause severe injury from the force of an air bag's deployment.

How Air Bags Work?

Air bags are designed to keep your head, neck, and chest from slamming into the instrument panel, steering wheel or windshield in a front-end crash. They are not designed to inflate in rear-end or rollover crashes or in most side-impact crashes. Your air bags are designed to deploy in crashes that are equivalent to, or exceed the force of a vehicle traveling at a speed of 15 to 23 km/h (9.3 ~ 14.3 mph) crashing into a solid immovable wall.

The air bag system activates during a severe collision which is either frontal or when the impact angle is up to 30° from straight ahead.

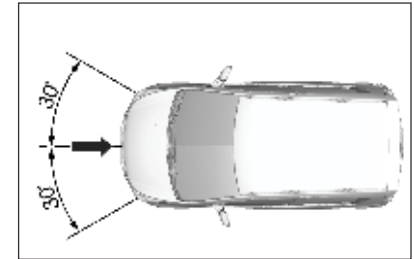

This crash severity level at which the air bag will deploy was selected to assure inflation of air bags in our vehicles at or below the crash severity at which a statistical risk of death begins for frontal collisions.

In the real world, cars rarely crash squarely into immovable walls; air bags most often deploy when a vehicle collides with another vehicle. The actual speed at which the air bags will inflate may be higher in the real world, because real-world accidents usually involve more complicated multi-vehicle impacts, angled impacts, and incomplete frontal impacts (e.g. sideswipes), and because the object struck is usually not immovable.

Note

An air bag can also inflate in moderate to severe non-collision situations (e.g., slamming the undercarriage or other solid component of the vehicle in a dip in the driving surface) where the crash sensors generate a signal equivalent to a crash into a solid immovable barrier at 15 to 23 km/h (9.3 ~ 14.3 mph).

Air bags inflate when a sensor detects a front-end crash of a severity sufficient for air bag deployment. The crash sensor sends an electric signal to initiate the air bag's inflation. A propellant is ignited which rapidly burns inside the air bag module, producing enough nitrogen gas to fully inflate the air bag. The chemical process and nitrogen gas are harmless to the vehicle's occupants. Within 0.045 seconds of the crash detection, the pressure of the inflating air bag splits open the plastic trim covering on the module, which is stored on the inside surface to allow the trim of the steering wheel hub or passenger-side instrument panel to split open under force.

The air bag fully inflates to create a surface that can catch the forward movement of the front occupant's head and upper torso. As the occupant comes into contact with the air bag, the gas in the bag empties through holes at the base of the bag to soak up the force from the occupant's forward movement.

Note

Air bags cannot smother you and they don't restrict your movement. Air bags have vents, so they deflate immediately after cushioning you.

The entire process, from initial contact through the air bag's inflation and deflation, occurs within 0.2 seconds, faster than the blink of an eye. Because the collision is over in a fraction of a second, and vehicles involved in an accident usually come to the final point of rest only one or two seconds after initial contact, the supplemental restraint system must sense the crash and cause the air bags to deploy nearly instantaneously to protect the vehicle's occupants.

Warning

The best protection can be provided only when the seat is in a proper position.

No obstacles are allowed within the inflation area of airbag.

Wear the seat belt correctly so that the air bag can provide protection.

After The Air Bag Deploys

After the air bag deflates, you may notice a burning smell, smoke, and white powder in the interior of the vehicle. This is normal. The burning smell is from the propellant that was ignited to inflate the airbag. The white powder is cornstarch or talcum or sodium compounds which lubricate the air bag to reduce friction on the air bag during storage and inflation. Although they may cause some skin or eye irritation, these substances are not toxic.

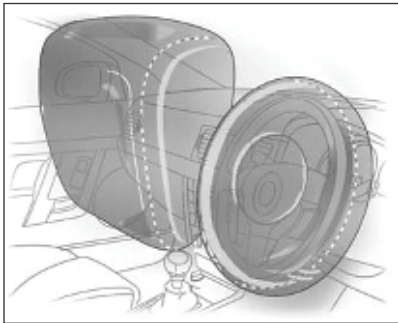

SRS Servicing

Your Supplemental Restraint System (SRS) is virtually maintenance free.

However, if any of the following occurs, have your SRS serviced immediately by CHEVROLET retailer.

- Any of your air bags have deployed.
- The air bag warning lamp indicates malfunction.

Warning

- Do not drive your vehicle after one or more air bags have deployed.
- Do not try to repair, alter, or dispose of the air bag yourself.
- Air bags are installed under high pressure with sophisticated crash sensing and air bag inflating systems. Allowing an untrained and unauthorized person to handle an air bag can lead to serious injuries and death.
- Contact your CHEVROLET retailer immediately if either of your vehicle's air bag has deployed, if damage occurs to your vehicle at or near either of the air bag modules, or if you believe for any reason that the operating condition of either air bag has been impaired.

Driving a vehicle after an air bag has deployed without authorized service can result in severe injuries and death.

How Air Bags Protect Front Occupants?

Vehicle occupants are usually injured in a collision because their bodies are thrown into a stationary object, either inside the vehicle, such as the steering wheel, instrument panel or windshield, or outside the vehicle, such as the driving surface or a tree, when the occupant is thrown from the vehicle. Severe injuries also occur by occupants being jolted by the forces of the crash, even without body contact with a stationary object or surface.

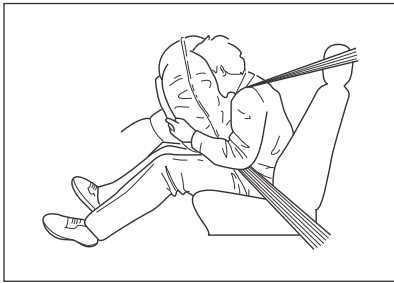

All of these injuries are caused by the force created by the collision as the vehicle is brought to a sudden stop. The time and distance which a vehicle is allowed in slowing or stopping in great part determines the severity of a collision's effect on vehicle occupants. For example, when a vehicle brakes to a stop at a red light, the occupant's bodies are forced forward. This is because both the vehicle and its occupants are initially traveling at the same speed. The brakes slow the vehicle, and the occupants continue to move forward somewhat inside the vehicle. However, properly positioned and restrained occupants are rarely injured when a vehicle comes to a stop by even sudden and hard braking. This is because even hard braking allows a comparatively long time and distance for the vehicle to stop. The safety belts and the occupants' strength are generally sufficient to safely counteract the force of a braking stop.

In a crash, a vehicle may go from highway speed to a full stop in a fraction of a second and in a distance of less than one foot. This extremely short stopping time and distance greatly increases the force placed upon the occupants. No person has the strength or reflexes to counteract this force. Even occupants properly positioned and wearing their safety belts will find their head, upper torso, arms, and hips thrown forward at the speed the vehicle was traveling before impact. In moderate to severe frontal collisions, even occupants wearing safety belts can sustain internal brain and organ injuries without the occupant's head or torso hitting any stationary objects or surfaces.

Air bags provide additional stopping time and distance for the head and upper torsos of front occupants in moderate to severe frontal or near-frontal collisions. This additional time and distance can save lives and prevent serious injuries.

Help Your Air Bags To Protect You

Besides their life saving benefits, the air bag system also poses some moderate risks.

Because an air bag inflates with considerable force, speed and suddenness, the air bag supplemental restraint system will be safer and more effective if the occupants are properly positioned and wear safety belts in the vehicle.

Warning

Essential Air Bag Safety Rules:

- Never place a rear-facing child seat in the front seat.
- Children age 12 years and under should ride in the back seat whenever possible.
- Always wear your safety belts, even if your vehicle is not equipped with an air bag.
- Move your seatback rearward as far as is comfortable and safe, tilt the seatback slightly and sit against the back of the seat.
- Do not place objects on, over or near the air bag modules. They can become projectiles during inflation, causing severe injury.
- Do not lean forward or rest any part of your body on the trim covering the air bag modules.
- Do not drive with the steering column tilt adjusted fully upward.

Severe injury and death can result from failing to observe these air bag safety rules.

Always secure any rear-facing child seat in the back seat.

Child restraint systems in which the child faces the rear of the seat must never be placed in the front seat. The deployment of an air bag risks severe injury or death to a child in a rear-facing child seat placed in the front seat.

Children should be seated in the back seat.

According to accident statistics, children age 12 years and under are safer when properly restrained in the back seat than in the front seat, and should ride in the back seat whenever possible. Children are safer in the back seat only because of the risks of injury by air bags. Studies have shown that children are also safer in the back seat than in a front seat without an air bag.

Proper positioning of adults and teenagers.

Adults and teenagers seated in the front driver and passenger seats can also improve their safety and the effectiveness of the air bags by using proper seating positions.

For the best seating position of adults and teenagers:

- Wear the three-point safety belts at all times.

All occupants, including the driver, should always wear their safety belts whether or not an air bag is also provided at their seating position to minimize the risk of severe injury or death in the event of a crash.

Air bags do not deploy in rear and side-impact collisions. Occupants not wearing their safety belts will not be protected by any restraint system, resulting in severe injuries or death in these types of collisions.

Occupants who are not properly wearing their safety belts may be thrown forward by braking before impact, placing their bodies near or against the air bag modules. This can cause severe injury from the force of air bag's deployment.

- Move the back of the seat rearward as far back as is comfortable and safe.

Positioning your seat farther away from the air bag module will not decrease the effectiveness of the air bag. Greater distance from the module means greater protection from the air bag's forceful and sudden deployment. Never move the driver's seatback so far as to impair the driver's ability to comfortably reach the steering wheel, pedals and other instrument and controls.

- Tilt the seat back slightly and do not lean forward.

Tilt the seatback slightly, and sit with your back against the back of the seat. Do not lean or otherwise position your body close - within 15 cm (6 inch) - to the air bag module. Do not rest any part of your body on or near the plastic trim covering the air bag module (the hub of the steering wheel or the passenger side of the instrument panel above the glove box). Try to keep your head and body more than 25 to 30 cm (10 to 12 inches) away from the air bag. More distance is safer.

▲ Warning

To perform well, an air bag must deploy quickly. The force is greatest in the first 5-8 cm (2-3 inches) after the air bag bursts through its cover and begins to inflate. Those 2 to 3 inches immediately after the air bag bursts through its module cover and begins to inflate are the risk zone.

- If an occupant's body is in this risk zone when the air bag deploys, severe injury or even death could result.
- The force decreases as the air bag inflates farther from the module cover.
- Greater distance from the air bag module means greater safety when the air bag deploys.

- Do not place objects, children or pets between you and the air bag module.

Your vehicle's air bag modules are located on the steering wheel and on the instrument panel above the glove box. Placing objects on, over or near the plastic trim covering these air bag modules could cause those objects to be propelled by the inflating air bag into your face and torso causing serious injury.

Children and pets should never ride on another occupant's lap. Do not place objects which could cause injury during deployment on an occupant's lap.

- Tilt the steering wheel downward (if so equipped), pointing the air bag towards your chest instead of your head and neck.

Never position the steering wheel at the highest position. This position should only be used to allow easy

entry and exit from the driver's seat. Lower the steering before starting to drive. This will aim the air bag at the driver's chest, rather than the more easily injured head and neck.

Note

The fact that your vehicle may be severely damaged and the air bags did not inflate or the fact that the vehicle is relatively undamaged and the air bag did inflate does not necessarily mean that there is something wrong with your air bag system. The crash sensors detect the severity of the crash, not the amount of damage to the vehicle.

CHILD RESTRAINTS*

Child Restraint Systems

When a child restraint system is being used, pay attention to the following usage and installation instructions supplied with the child restraint system.

Always comply with local or national regulations. In some countries, the use of child restraint systems is forbidden on certain seats.



Warning

NEVER use a rearward facing child restraint on a seat protected by an ACTIVE AIRBAG in front of it, DEATH or SERIOUS INJURY to the CHILD can occur.

Selecting The Right System

Children should travel facing rearwards in the vehicle as long as possible. This makes sure that the child's backbone, which is still very weak, is under less strain in the event of an accident.

Children under 12 years or under 150 cm tall should only travel in an appropriate child safety seat.

Never carry a child whilst traveling in the vehicle. The child will become too heavy to hold in the event of a collision.

When transporting children, use the child restraint systems suitable for the child's weight.

Ensure that the child restraint system to be installed is compatible with the vehicle type.

Warning

If the vehicle is equipped with a lap belt on the rear center seat, no child restraint system is allowed on this seat. It is advised to mount the child restraint system only on one of the rear outer seats.

Ensure that the mounting location of the child restraint system within the vehicle is correct.

Allow children to enter and exit the vehicle only on the side facing away from the traffic.

When the child restraint system is not in use, secure the seat with a seat belt or remove it from the vehicle.

Note

Do not stick anything on the child restraint systems and do not cover them with any other materials.

A child restraint system which has been subjected to stress in an accident must be replaced.

Please ensure that infants and children are seated in the rear seats using child restraints.

Until the children can use seat belts, please select a child restraint suitable for its age and make sure the child wears it. Please see the instructions on the relevant products for child restraints.

STORAGE

Storage compartments	45
Luggage / load locations	47
Additional storage features*	49
Information on loading the vehicle .	49

STORAGE COMPARTMENTS

Instrument Panel Storage

Storage on top of the instrument panel

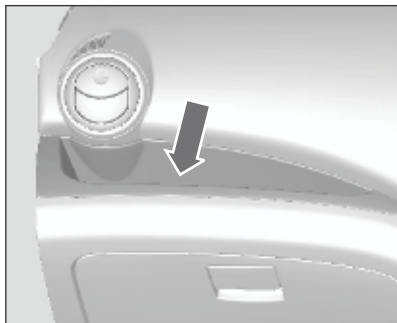

The storage is used for small articles, etc.

⚠ Warning

Do not store heavy or sharp objects in the storage compartments. Otherwise, vehicle occupants could be injured by objects being thrown around in the event of hard braking, a sudden change in direction or an accident.

Coin Box



Store your coins in a place.

Glovebox

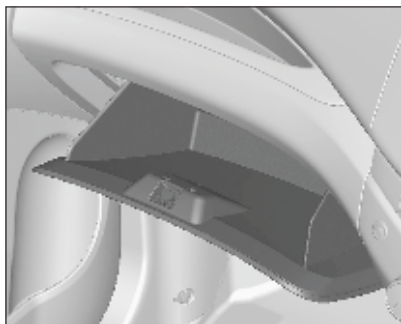

To open pull the grip.

⚠ Warning

To reduce the risk of injury in an accident or a sudden stop, always keep the glovebox door closed while driving.

Cupholder

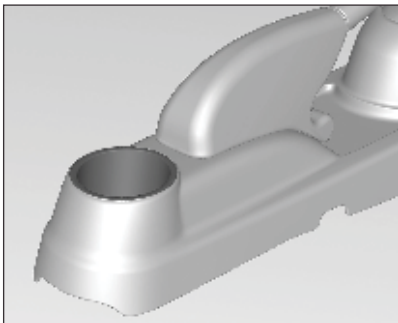

The cup holders are located in the front console and rear part of the center console.

⚠ Warning

Do not place uncovered cups of hot liquid in the cup holder while the vehicle is in motion. If the hot liquid spills, you burn yourself. Such a burn to the driver could lead to loss of control of the vehicle.

To reduce the risk of personal injury in the event of sudden stop or collision, do not place uncovered or unsecured bottles, glasses, cans, etc., in the cup holder while the vehicle is in motion.

LUGGAGE/LOAD LOCATIONS

Luggage Compartment

Folding down rear seat backrests

Warning

Do not stack luggage or other cargo higher than the front seats.

Do not allow passengers to sit on the folded seatbacks while the vehicle is in motion.

Unrestrained luggage or passengers on a folded seatback can be thrown about within or ejected from the vehicle in a sudden stop or accident.

Serious injuries or death can result.

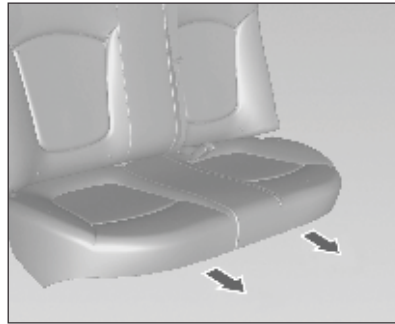

To fold down the rear seat backs separately:

1. Pull up under the front of the rear seat cushion to release it.
2. Guide the released rear seat cushion to an upright position.
3. Disengage the seat tie rods from the body brackets and snap into the bracket against the cushion.

Ensure that all the seat tie rods are disengaged from the body.

Note

To ensure enough room for rear seat cushion operation, slide the front seat forward and adjust the front seatback upright.

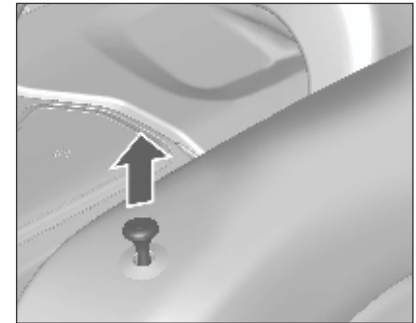

4. Pull up the release knob on top of the rear seatback and fold it forward and down.

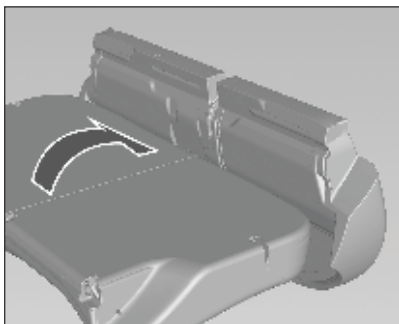

- Adjust the front seats to the desired position.

To return the seatback to the upright position, lift it up and push it firmly into place.

To return the rear seat cushion, engage the seat tie rods in to body brackets, put the rear part of the seat cushion in its original position, then push the front part of the seat cushion firmly down until it latches.

Caution

When returning rear seatback to the upright position, place the rear safety belt and buckles between the rear seatback and one cushion. Make sure the rear safety belt and buckles are not to be pinched under the rear seat cushion.

Make sure the safety belts are not twisted or caught in the seatback and are arranged in their proper position.

⚠ Warning

Ensure that the rear seatbacks are all the way back and locked in position before operating the vehicle with passengers in the back seat.

Do not pull the release knobs on the top of the seatback while the vehicle is moving.

It can cause injuries or damage to the occupants.

Caution

Folding a rear seat with the safety belts still fastened may cause damage to the seat or the safety belts.

Always unbuckle the safety belts and return them to their normal stowed position before folding a rear seat.

⚠ Warning

Never allow passengers to sit on top of the folded down seatback, while the car is moving as this is not a proper seating position and no seat belts are available for use.

This could result in serious injury or death in case of an accident or sudden stop.

Objects carried on the folded down seatback should not extend higher than the top of the front seats. This could allow cargo to slide forward and cause injury or damage during sudden stops.

ADDITIONAL STORAGE FEATURES*

Convenience Net

You can carry small loads with your optional convenience net.

To install the net, hang each loop in the upper corner of the net to both anchors of the back panel.

Caution

The convenience net is designed for small loads. Do not carry heavy objects in your convenience net.

INFORMATION ON LOADING THE VEHICLE

- Heavy objects in the load compartment should be placed against the seat backrests. Ensure the backrests are securely engaged. If objects can be stacked, the heavier objects should be placed at the bottom.
 - Secure objects in load compartment to prevent sliding.
 - When transporting objects in the load compartment, the backrests of the rear seats must not be angled forward.
 - Do not allow the load to protrude above the upper edge of the backrests.
 - Do not place any objects on the load compartment cover or on top of the instrument panel.
 - The load must not obstruct the operation of the pedals, parking brake and gear selector, or hinder the freedom of movement of the driver. Do not place any unsecured objects in the interior.
- Do not drive with an open load compartment.
 - The payload is the difference between the permitted gross vehicle weight (see *Identification plate* on page 139) and the kerb weight. For the kerb weight in detail, refer to the technical data section. The kerb weight includes weights for the driver (68 kg), luggage (7 kg) and all fluids (tank 90 % full). Optional equipment and accessories increase the kerb weight.
 - Driving with a roof load increases the sensitivity of the vehicle to cross-winds and has a detrimental effect on vehicle handling due to the vehicle's higher center of gravity. Distribute the load evenly and secure it properly with retaining straps. Adjust the tire pressure and vehicle speed according to the load conditions. Check and retighten the straps frequently.

INSTRUMENTS AND CONTROLS

Controls 51
 Windshield wiper/washer 52
 Clock 54
 Power outlets* 54
 Cigarette lighter* 54
 Warning lights, gauges and
 indicators..... 56

CONTROLS

Steering Wheel Adjustment*



Unlock lever, adjust steering wheel, then engage lever and ensure it is fully locked.

Do not adjust steering wheel unless vehicle is stationary.

Caution

If strong impact delivers to steering column axle direction when the steering wheel is adjusted or the lever is locked, it may cause damage to the parts related to steering wheel.

Horn



Press the  switch on the steering wheel pad to sound the horn.

Steering Wheel Audio Controls*

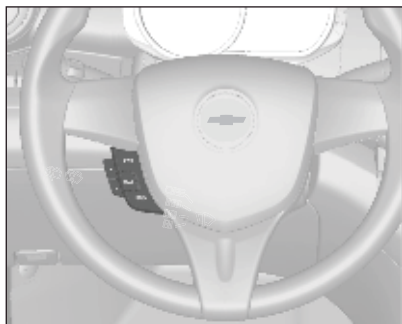

The infotainment system can be operated by the controls on the steering wheel.

Further information is available in the infotainment section.

WINDSHIELD WIPER/ WASHER

Windshield Wiper

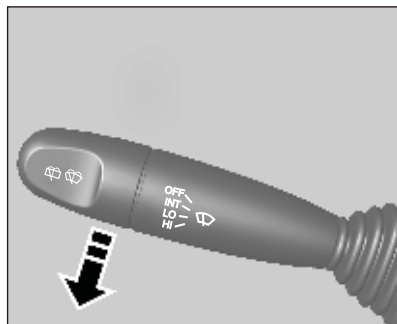

To operate the windshield wipers, turn the ignition ON and move the windshield wiper/washer lever downward.

- OFF** : System off.
- INT** : Intermittent operation.
- LO** : Continuous wipe, slow speed.
- HI** : Continuous wipe, fast speed.

Misting function

To operate the windshield wipers once in case of light rain or mist, lightly move the windshield wiper/washer lever towards the INT position and release it.

The lever will return automatically to its normal position when released. The wipers will operate through one cycle.

Caution

Less than clear vision for the driver can lead to an accident resulting in personal injury and damage to your vehicle or other property.

Do not operate the windshield wipers when the windshield is dry or obstructed, as with snow or ice. Using the wipers on an obstructed windshield can damage the wiper blades, wiper motor, and glass.

Check blades are not frozen to windshield before operating in cold weather. Wiper operation while blade is frozen can damage wiper motor.

Windshield Washer

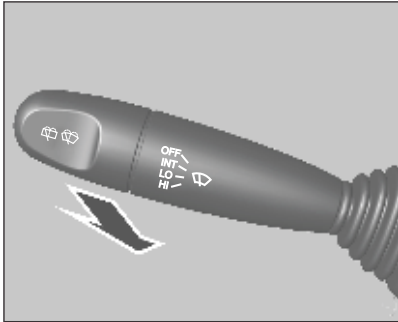

Pull lever. Washer fluid is sprayed onto the windshield and the wiper wipes for a few strokes.

Caution

Do not operate the windshield washer continuously for more than some seconds, or when the washer fluid tank is empty. This can cause the washer motor to overheat resulting in costly repairs.

Warning

Do not spray washer fluid on the windshield/tailgate window in freezing weather.

Using washer fluid and wipers may cause an accident in freezing weather because washer fluid can form ice on a frozen windshield/tailgate window and obstruct your vision.

Rear Window Wiper/Washer

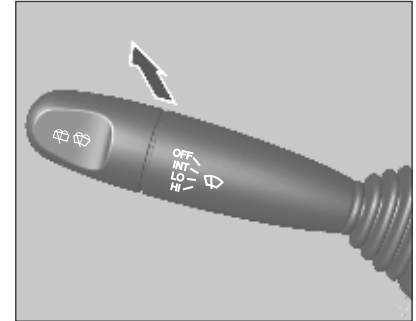

To operate the tailgate wiper and washer, push the lever towards the instrument panel. Pushing once, wiper will operate continuously at slow speed. To spray the washer fluid, push the lever once more.

Caution

Do not operate the tailgate window washer continuously for more than some seconds, or when the washer fluid tank is empty. This can cause the washer motor to overheat resulting in costly repairs.

CLOCK



Time is shown in the cluster.

Set time

Push the **CLOCK** button of the cluster for more than 1 second. When the hour display flashes, adjust the current hour using the **CLOCK** button.

After for a second, the minute display will flash automatically then adjust the current minute using the **CLOCK** button.

The setting will be finished without any operation after adjusting in few seconds.

POWER OUTLETS*

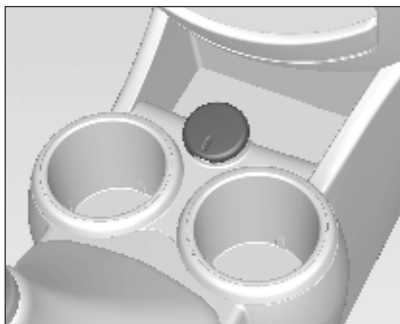

A 12V power outlet is located in the front console.

Do not exceed the maximum power consumption of 120 W.

With ignition off the power outlet is deactivated.

Additionally the power outlet is deactivated in case of low battery voltage.

Caution

Do not connect any current delivering accessories, e.g. electrical charging devices or batteries.

Do not damage the sockets by using unsuitable plugs.

CIGARETTE LIGHTER*

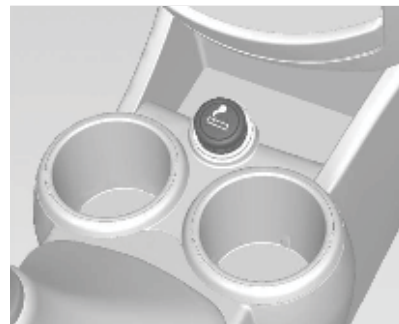

To operate the cigar lighter, turn the ignition switch to **ACC** or **ON** and push the lighter in all the way.

The cigar lighter will pop out automatically when it is ready to use.

Caution

Overheating the cigarette lighter can damage the heating element and the lighter itself.

Do not hold the lighter in while it is heating. This can cause the lighter to overheat.

Trying to operate a malfunctioning cigarette lighter can be dangerous. If the heated cigarette lighter does not pop out within 25 seconds, pull it out and consult a CHEVROLET retailer to have it repaired. It can cause injuries and damage to your vehicle.

⚠ Warning

If you leave the vehicle with an inflammable explosive substance, such as a disposable lighter, inside the vehicle in summer, it can explode and cause fire due to an increase of temperature in the passenger compartment and the boot.

Please ensure that no inflammable explosive substances are left or kept inside the vehicle.

Caution

The cigarette socket should only be used with the cigarette lighter. If other 12V power adapters are installed into the cigarette socket, fuse failure or a potential thermal incident may occur.

Caution

The barrel of an operating cigarette lighter can become very hot.

Do not touch the barrel of the cigarette lighter and do not allow children to operate or play with the cigarette lighter.

This hot metal can cause personal injuries and damage to your vehicle or other property.

WARNING LIGHTS, GAUGES AND INDICATORS

Speedometer



The speedometer shows the vehicle's speed in kilometers per hour (km/h).

Note

In a speed limit zone, please keep to the speed limit.

Odometer



The odometer shows how far your vehicle has been driven in kilometers.

There are two independent trip odometers, which measure the distances your vehicle has travelled since you last reset this function.

The ODO, TRIP A and TRIP B can be switched by pressing the TRIP button.

Note

To reset each trip odometer to zero, press the TRIP button of the cluster more than 2 seconds.

Caution

It is prohibited by law to operate the odometer illegally.

Tachometer



Displays the engine speed in revolutions per minute (rpm).

Drive in a low engine speed range for each gear as much as possible.

Fuel Gauge



Displays the fuel level in the tank.

Because of the fuel remaining in the tank, the top-up quantity may be less than the specified tank capacity.

The fuel gauge display first bar flashes when level in fuel tank is too low.

Movement of the fuel within the fuel tank causes the fuel gauge display to change when you brake, accelerate or turn.

⚠ Danger

Before refueling, stop vehicle and switch off the engine. Never run the tank dry.

⚠ Danger

Before refueling, switch off engine and any external heaters with combustion chambers. Switch off any mobile phone.

Vaporised fuel can be ignited by electromagnetic waves or electric current of mobile phone.

Fuel is flammable and explosive. No smoking. No naked flames or sparks. Follow the operating and safety instructions of the filling station when refueling.

Remove static electricity on your hands by touching something able to release static electricity when touching or opening fuel cap or refueling nozzle.

Don't do any action making static electricity like getting on and off vehicle when refueling. Vaporised fuel can be ignited by static electricity.

Control Indicators

The control indicators described are not present in all vehicles. The description applies to all instrument versions. When the ignition is switched on, most control indicators will illuminate briefly as a functionality test.

The control indicator colours mean:

Red = Danger, important reminder

Yellow = Warning, information, fault

Green = Confirmation of activation

Blue = Confirmation of activation

Control Indicators In The Instrument Cluster

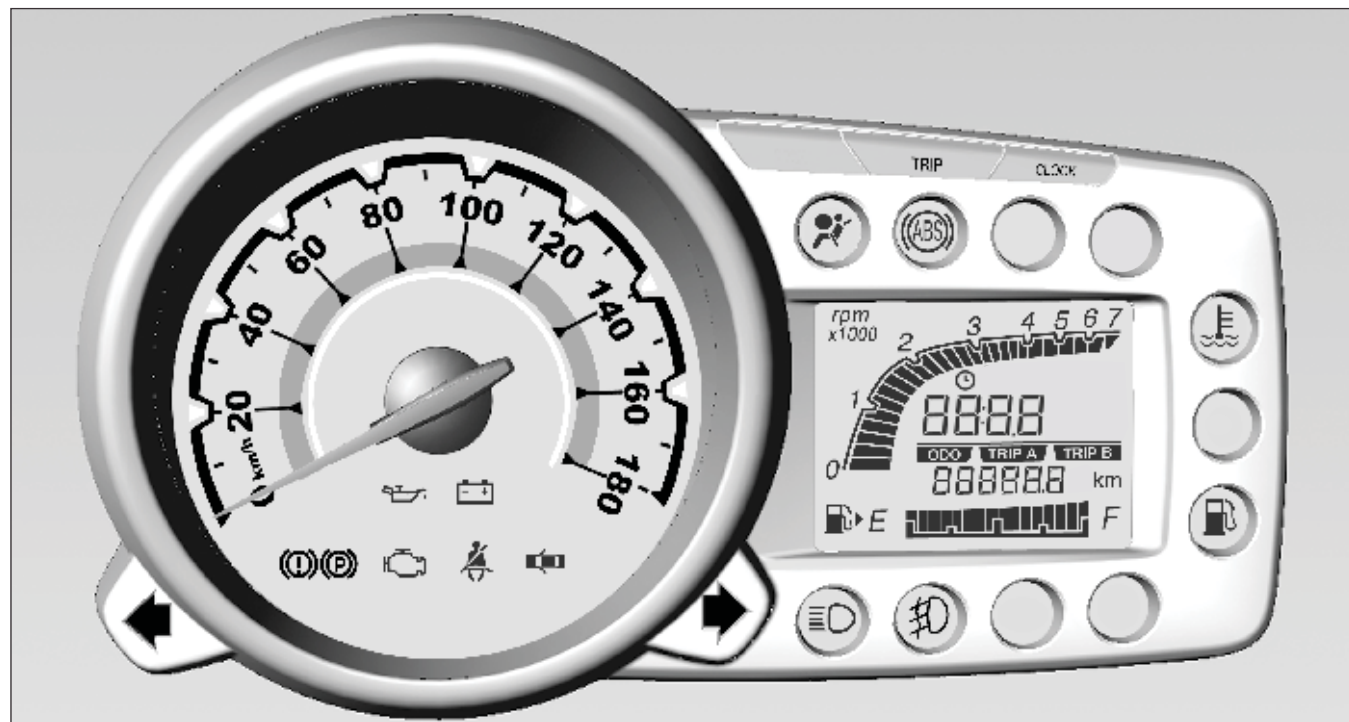

Turn Signal

 illuminates or flashes green.

Flashes

The control indicator flashes if a turn signal or the hazard warning flashers are activated.

Fast flashing

Failure of a turn signal light or associated fuse.

See *Bulb replacement* on page 109.

See *Fuses* on page 115.

See *Turn and Lane-Change Signals* on page 66.

Seat Belt Reminder*

Safety belt reminder on front seat

 for driver's seat illuminates or flashes red.

1. After the ignition is switched on, the control indicator flashes for few seconds and then illuminates steadily until the safety belt is fastened.
2. After the engine is running, the control indicator flashes for few seconds and then illuminates

steadily until the safety belt is fastened.

3. If the vehicle moves more than 250 m (0.15 mile) or the speed is over 22 km/h (14 mph) with unfastened safety belt, the control indicator will flash.

The indicator will illuminate until the safety belt is fastened.

Airbag Warning Light*

 illuminates red.

When the ignition is switched on, the control indicator illuminates for about few seconds. If it does not illuminate, does not go out after few seconds or illuminates whilst driving, there is a fault in the airbag system. The systems may fail to trigger in the event of an accident.

Vehicle trouble or deployment of the airbags may be indicated by continuous illumination of .

Warning

Have the cause of the fault eliminated immediately by a CHEVROLET retailer.

See *Airbag system* on page 35.

See *Safety belts* on page 35.

Charging System Light

 illuminates red.

It illuminates when the ignition is switched on and goes out shortly after the engine starts.

Illuminates when the engine is running

Stop, switch off the engine. Battery is not charging. Engine cooling may be interrupted.

Seek the assistance of a CHEVROLET retailer.

Malfunction Indicator Light

 illuminates yellow.

It illuminates when the ignition is switched on and goes out shortly after the engine starts.

Brake System Warning Light

 illuminates red.

It illuminates when the ignition is switched on and goes out shortly after the engine starts.

Illuminates when the parking brake is released, if the brake fluid level is too low or if there is a brake system fault.

See *Brake fluid* on page 106.

Warning

Do not drive with the brake system warning lamp on.

This may mean your brakes are not working properly.

Driving with malfunctioning brakes can lead to a collision resulting in personal injuries and damage to your vehicle and other property.

Illuminates after the ignition is switched on if the manual parking brake is applied.

See *Parking brake* on page 92.

Antilock Brake System (ABS) Warning Light*

 illuminates yellow.

Illuminates for a few seconds after the ignition is switched on. The system is ready for operation when the control indicator goes out.

If the control indicator does not go out after a few seconds, or if it illuminates

while driving, there is a fault in the ABS. The brake system remains operational but without ABS regulation.

See *Antilock brake system (ABS)* on page 91.

Engine Coolant Temperature Warning Light

 illuminates red.

This lamp tells you that the engine coolant has overheated.

If you have been operating your vehicle under normal driving conditions, you should pull off the road, stop your vehicle and let the engine idle for a few minutes.

If the lamp does not go out, you should switch the engine off and consult a CHEVROLET retailer as soon as possible.

Engine Oil Pressure Light

 illuminates red.

It illuminates when the ignition is switched on and goes out shortly after the engine starts.

Illuminates when the engine is running

Caution

Engine lubrication may be interrupted. This may result in damage to the engine and/or locking of the drive wheels.

If the engine oil pressure warning lamp comes on while driving, pull off the road, stop the engine and check the oil level.

Warning

When the engine is off, considerably more force is needed to brake and steer. Do not remove key until vehicle has come to a standstill, otherwise the steering column lock could engage unexpectedly.

Check oil level before seeking the assistance of a CHEVROLET retailer.

See *Engine oil* on page 102.

Low Fuel Warning Light

 illuminates yellow.

Illuminates when level in fuel tank is too low.

Caution

Do not let your vehicle run out of fuel. This can damage the catalytic converter.

See *Catalytic converter* on page 93.

High - Beam On Light

 illuminates blue.

Illuminates when high beam is on and during headlight flash.

See *Headlamp high/low-beam changer* on page 64.

Fog Lamp Indicator Light*

 illuminates green.

Illuminates when the front fog lamps are on.

See *Front fog lamps* on page 66.

Door Ajar Light

 illuminates red.

It illuminates when a door is open or not securely latched. Before driving, check that all doors are properly closed.

LIGHTING



Exterior lighting	63
Interior lighting	67
Lighting features	68

EXTERIOR LIGHTING

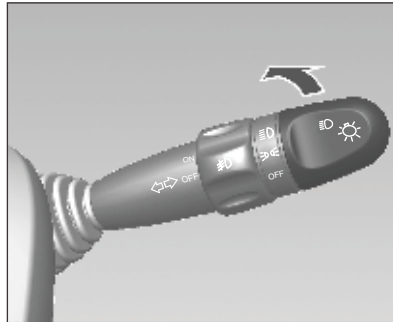
Exterior Lamp Controls



To turn the head and tail lamps on or off, twist the end of the combination switch lever. The light switch has three positions which activates various lamp functions as follows:

- OFF** : All the lamps are off.
-  : The parking lamps, tail lamps, number plate lamps and instrument panel lamps are illuminated.
-  : The low-beam headlamps and all of the above lamps are illuminated.

The parking lamps will turn off automatically when the driver's door is opened after the ignition switch is turned to LOCK.

Headlamp High/Low-Beam Changer

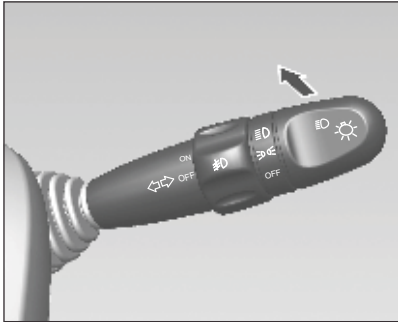

To switch from low to high beam, push lever.

To switch to low beam, pull lever.

Note

The headlamp high-beam on indicator illuminates when headlamps are on high beam.

Warning

Always switch the high-beam headlamps to low-beam when you approach on coming vehicles or when other vehicles are ahead.

High-beam headlamps can temporarily blind other drivers, which could result in a collision.

Flash - To - Pass

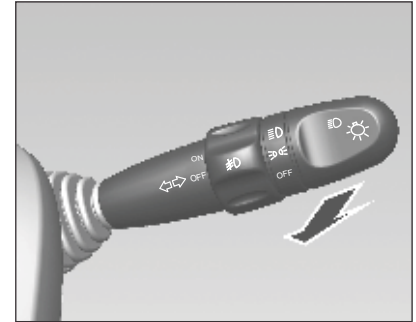

The flash- to-pass feature works with the low beams on or off.

To flash the high beams, pull the combination switch lever all the way towards you, then release it.

The lever will return to its normal position when you release it. The high-beam headlamps will stay on as long as you hold the combination switch lever towards you.

Headlamp Range Adjustment



To adapt headlamp range to the vehicle load to prevent dazzling: turn knob  to required position.

- 0 = Front seats occupied.
- 1 = All seats occupied.
- 2 = All seats occupied and load compartment laden.
- 3 = Driver's seat occupied and load compartment laden.

Headlamps when driving abroad

The asymmetrical headlamp beam extends visibility at the edge of the road at the passenger side.

However, when driving in countries where traffic drives on the opposite side of the road, adjust the headlamp to prevent dazzling of oncoming traffic.

Have the headlamp adjusted by a CHEVROLET retailer.

Hazard Warning Flashers

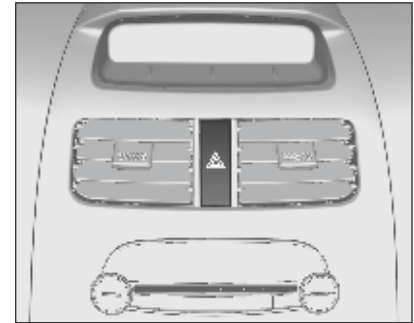

Operated with the  button.

To activate the hazard warning flashers, push the button.

To turn off the flashers, push the button again.

Turn And Lane-Change Signals

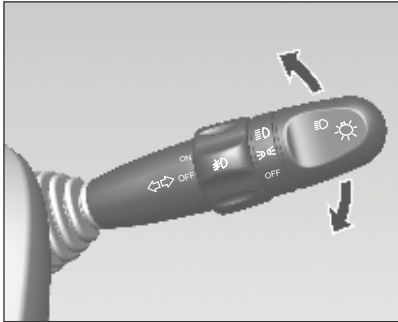

Lever up = Left indicator
Lever down = Right indicator

If the lever is moved past the resistance point, the indicator is switched on constantly. When the steering wheel moves back, the indicator is automatically deactivated.

Front Fog Lamps*

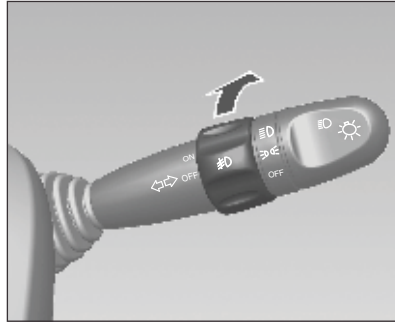

To turn the fog lamps on, make sure the parking lamps are on.

And turn the ring on the middle of the combination switch lever to ON position.

To turn the fog lamps off, turn the ring to the OFF position.

Reversing Lamps

The reversing lamps come on when the ignition is on and reverse gear is selected.

Misted Lamp Covers

The inside of the lamp housing may mist up briefly in poor, wet and cold weather conditions, in heavy rain or after washing. The mist disappears quickly by itself. To help switch on the headlamps.

INTERIOR LIGHTING

Courtesy Lamp

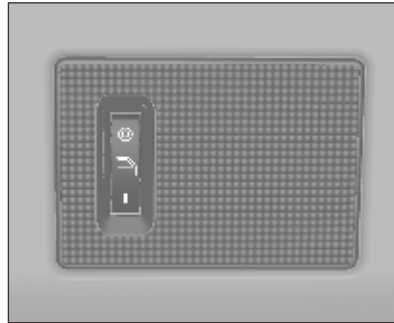

Operate rocker switch:

- : Always off, even when doors are open.
- ☺ : Automatic switching on when you open a door and off after doors are closed.
- : Always on until shut off manually.

Note

The battery can be discharged if the lamp keep turning on for a long time

Warning

Avoid using the courtesy lamp while driving in the dark.

A lit passenger compartment reduces visibility in the dark, and could cause a collision.

LIGHTING FEATURES

Battery Power Protection

Switching off electric lights

Battery saver is to prevent the battery from being discharged.

If you open the driver's door, parking lamps are turned off automatically when the ignition is switched to LOCK or ACC position.

The headlamps are turned off, when ignition is switched to LOCK or ACC position.

The courtesy lamp will not be applied with this function.

INFOTAINMENT SYSTEM*

Introduction 69
 Radio 73
 Audio players 75
 Steering wheel audio controls* 77

INTRODUCTION

Infotainment

Before using the device for the first time, please read the following pages to become familiar with its features.

⚠ Warning
Taking your eyes off the road for extended periods could cause a crash resulting in injury or death to you or others. Do not give extended attention to infotainment tasks while driving.

This system provides access to many audio and non audio listings.

To minimize taking your eyes off the road while driving, do the following while the vehicle is parked:

- Become familiar with the operation and controls of the audio system.
- Set up the tone, speaker adjustments, and preset radio stations.

Caution
Contact your CHEVROLET retailer before adding any equipment. Adding audio or communication equipment could interfere with the operation of the engine, radio, or other systems, and could damage them. Follow federal rules covering mobile radio and telephone equipment.

Overview

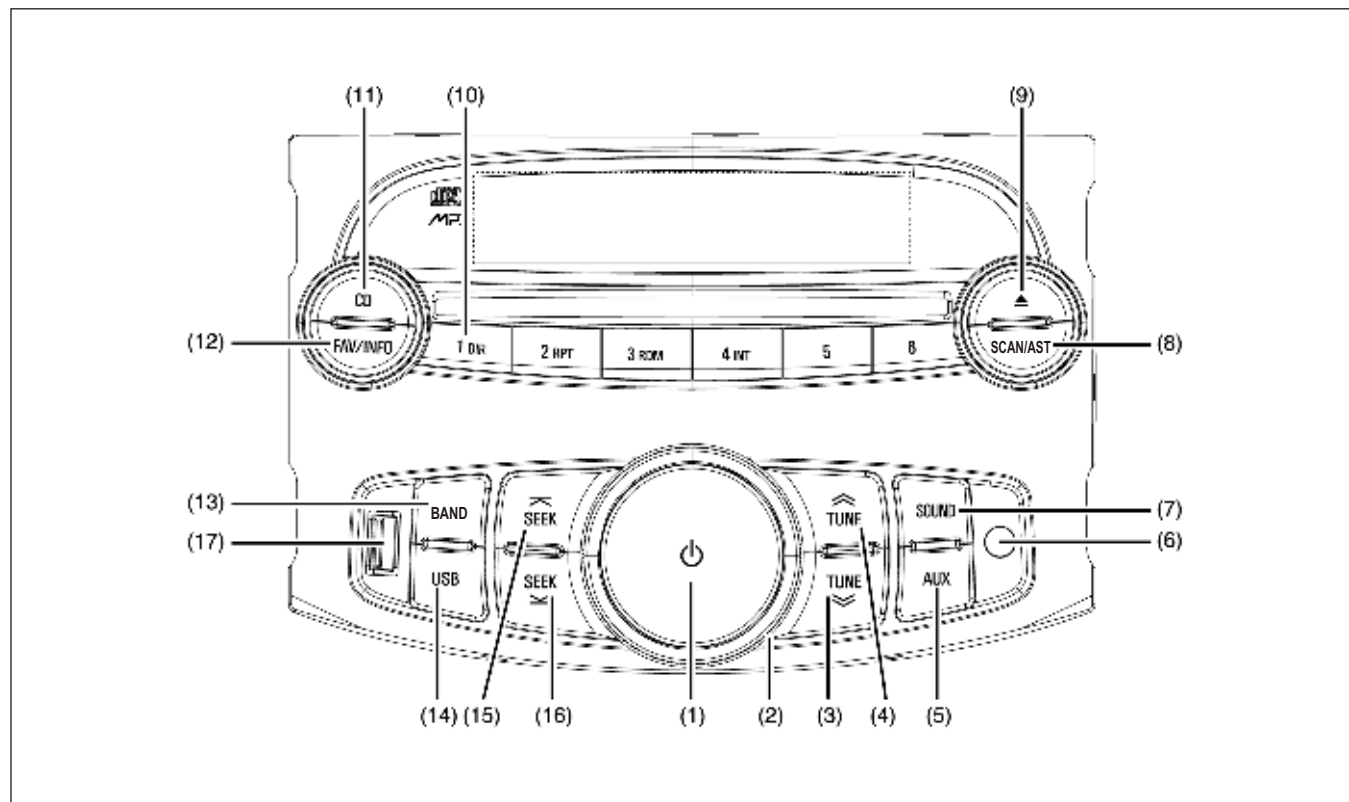

1. [POWER]

- When the power is ON:
 - Short Press: Audio mute on/off.
 - Long Press: Turns on/off the radio.
- When the power is OFF:
 - Pressing the power button turns the power ON.

2. [VOLUME]

- Volume adjustment.
- Tone adjustment in the tone control mode.

3. [TUNE DOWN]

- Radio mode
 - Short Press: 1 step tune-down.
 - Long Press: Continuous tune-down.
- CD mode
 - Short Press: Previous track or file playback.
 - Long Press: Fast-reverse playback.

4. [TUNE UP]

- Radio mode
 - Short Press: 1 step tune-up.
 - Long Press: Continuous tune-up.
- CD mode
 - Short Press: Next track or file playback.
 - Long Press: Fast-forward playback.

5. [AUX]

- Auxiliary mode selection.

6. [Aux Socket]

- Socket of Auxiliary Jack.

7. [SOUND]

- Bass/Middle/Treble/Fader/Balance/Preset EQ adjustment.

8. [SCAN/AST]

- Short Press: Traffic announcement reception setting.
- Long Press: Configuration setting.
 - Fav. Page 1~6: Favorite page setting.

- Auto-store function, search and memory the best stations.

9. [EJECT]

- Eject the disc from the CD deck.

10. [PRESET] #1~#6

- Radio mode
 - Short Press: Recall the pre-memorized station in the preset memory.
 - Long Press: Store to preset memory.
- CD mode
 - [#1 DIR]: Enable or disable directory playback mode.
 - [#2 RPT]: Enable or disable repeat playback mode.
 - [#3 RDM]: Enable or disable random playback mode.
 - [#4 INT]: Enable or disable intro-scan playback mode.

11. [CD]

- Compact Disc playback mode selection.
- CD pause function when CD playback.

12. [FAV/INFO]

- Radio mode
 - Short Press: Selection favorite page.
 - Long Press: Information display of the current station.
- CD mode
 - Short Press: Information display of the current track.

13. [BAND]

- Radio mode selection.
- Radio mode
 - Short Press: AM or FM radio band selection.

14. [USB]

- USB mode selection.
- USB Pause function when USB playback.

15. [SEEK UP]

- Radio mode
 - Next broadcasting station search upward.

- CD mode
 - Next folder when CD playback.

16. [SEEK DOWN]

- Radio mode
 - Previous broadcasting station search downward.
- CD mode
 - Previous folder when CD playback.

17. [USB SOCKET]

- Socket of USB.

Operation

Power On/Off

Power On

- ⇒ Press [POWER] to turn on the radio.

Power Off

- ⇒ Press [POWER] and hold more than 1 second to turn off the radio.

Audio Mute

Press [POWER] to make audio mute when the power is on.

Volume Adjustment

Turn the volume clockwise to increase the audio volume.

Turn the volume counter-clockwise to decrease the audio volume.

Audio Adjustment

Bass Tone Adjustment

Press the [SOUND] repeatedly until radio show "Bass" and turn the [VOLUME] knob clockwise or counter-clockwise to increase or decrease the bass effect.

Midrange, Treble, Balance & Fader Adjustment

Almost same with above "Bass Tone Adjustment" but select each tone mode.

Preset EQ Selection

Almost same with above "Bass Tone Adjustment" but select preset EQ mode

The kinds of preset EQ Mode are

...→OFF→POP→Rock→Country→

Voice→Jazz→Classic→OFF→...

RADIO

AM - FM Radio

Radio Mode Selection

Press the [BAND] to listen the radio from other mode.

Band Change

The band changes from AM to FM or FM to AM all times [BAND] pressed.

Manual Tune Up/Down

Press [TUNE UP]/[TUNE DOWN] to increase/decrease the frequency.

The frequency increase or decrease 1 step all times [TUNE UP]/[TUNE DOWN] pressed.

If this button is pressed continuously, then the frequency increase or decrease continuously.

Seek Up/Down

Press [SEEK UP]/[SEEK DOWN] to find next/previous station automatically.

Favorite Preset Memory

It has 6 favorite pages and store up to 48 stations regardless of AM or FM band.

It can store current station by the following procedure

Step 1: Seek station or tune station manually you want.

Step 2: Select the favorite page by pressing [FAV/INFO].

Step 3: Press and hold [PRESET #] more than 1 second.

By above procedure, the 48 stations are stored in the favorite preset memory.

Recall Favorite Preset

You can listen to the station stored in the favorite preset by the following procedure.

Step 1: Select the favorite page by pressing [FAV/INFO].

Step 2: Press [PRESET #] which store the station you want to listen to.

Auto-Store Function

Auto-Store

Press [SCAN/AST] more than 1 second, then radio starts auto-store function, search and memory the best stations.

Radio Reception

Radio reception may be disrupted by static, noise, distortion or loss of reception due to

- Changes in distance from the transmitter,
- Multipath reception due to reflection and
- Shadowing.

Fixed Mast Antenna

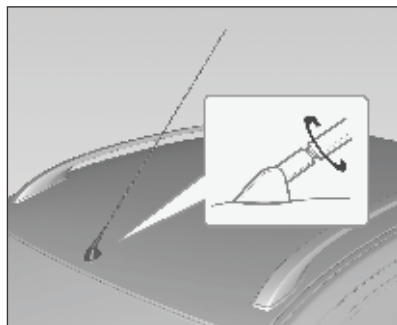

To remove the roof antenna, rotate it counterclockwise. To install the roof antenna, rotate it clockwise.

Caution

Be sure to remove the antenna before entering a place with a low ceiling or it may be damaged.

Entering the automatic car wash with the antenna installed may result in damage to the antenna or the roof panel. Be sure to remove your antenna before entering the automatic car wash.

Install the antenna fully tightened and adjusted to the upright position to ensure proper reception.

AUDIO PLAYERS

CD Player

As the CD is inserted, the radio will appear on the display and as the CD is loading, file check will appear on the display.

Once playback begins, the track and track number will appear on the display.

If the ignition or radio is turned off with a CD in the player, it will stay in the player. When the ignition and radio are turned on, the CD will start playing where it stopped, if it was the last selected audio source.

If playing a CD-R, the sound quality may be reduced due to CD-R quality, the method of recording, the quality of the music that has been recorded, and the way the CD-R has been handled. There may be an increase in skipping, difficulty in finding tracks, and/or difficulty in loading and ejecting. If these problems occur, check the bottom surface of the CD. If the surface of the CD is damaged, such as cracked, broken, or scratched, the CD will not play properly.

If there is no apparent damage, try a known good CD.

Do not add any label to a CD, it could get caught in the CD player. If a CD is recorded on a personal computer and a description label is needed, try labeling the top of the recorded CD with a marking pen instead.

Caution

If you add any label to a CD, insert more than one CD into the slot at a time, or attempt to play scratched or damaged CD's, you could damage the CD player. When using the CD player, use only CD's in good condition without any label, load one CD at a time, and keep the CD player and the loading slot free of foreign materials, liquids, and debris.

Disc Insert

Insert a CD into a CD slot with CD label up.

CD Playback Mode Selection

Insert a CD into CD deck, then the CD goes to the playback mode.

CDEJECT

Press the [EJECT], then the disc will be ejected from the radio.

Pull the disc out of the radio.

Pause

Press [CD] to pause playback while a CD is playing back.

“PAUSE” will flash on the display.

Press [CD] again to start playback.

Next/Previous Track

Press [TUNE UP/TUNE DOWN], then the CD starts playback of the next/previous track.

Fast Forward/Fast Reverse

Press and hold [TUNE UP/TUNE DOWN], then the CD plays back fast forward/fast reverse.

Next/Previous Folder - Only MP3*

Press [SEEK UP/SEEK DOWN], then the radio start playback of the next/previous track.

DIR (Directory):

Press [1 DIR], then CD plays back the tracks in the current directory.

To cancel this function, press [1 DIR] again.

RPT (Repeat):

Press [2 RPT], then CD plays back current track repeatedly.

To cancel this function, press [2 RPT] again.

RDM (Random):

Press [3 RDM], then CD plays back tracks randomly.

To cancel this function, press [3 RDM] again.

INT (Intro-Scan):

Press [4 INT], then CD plays back just 10 seconds of the current track, jump to next track and do this action repeatedly.

To cancel this function, press [4 INT] again.

Auxiliary Devices

USB Playback Mode*

USB Playback Mode Selection

Press the [USB] to change to play back the USB files from other mode.

USB Memory Insertion

Insert a USB memory into the USB socket, so the radio plays back the USB files automatically.

USB Extraction

Pull the USB memory from the USB socket by hand.

*** Other functions are same with CD mode.**

AUX Mode

The radio has one auxiliary input jack(diameter 3.5mm) located on the lower right side of the faceplate.

This is not an audio output; do not plug the headphone set into the front auxiliary input jack.

You can however, connect an external audio device such as an iPod, laptop computer, MP3 player, CD changer, receiver, etc. to the auxiliary input jack for use as another source for audio listening.

AUX In Mode Selection

Press [AUX] in the other playback mode.

If the auxiliary jack isn't detected for the presence of an output jack, the aux mode will be prevented.

STEERING WHEEL AUDIO CONTROLS*

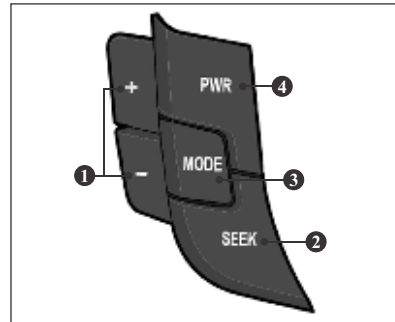

1. VOLUME [+/-] Buttons

- Press the buttons to increase / decrease the volume step.
- Hold down the buttons to quickly up/down the volume level.

2. SEEK Button

- Press the button to change the registered radio stations or music track being played.
- Hold down the button to quickly seek up the frequency or forward through the currently playing songs.

3. MODE Button

- Press the button to select Radio, AUX or CD/MP3/USB/iPod audio function.

4. POWER[PWR]/MUTE Button

- Press the button in standby mode to turn the infotainment system ON.
- Press the button in any music play mode to turn the mute function ON/OFF.
- Press and hold the button to turn the infotainment system OFF.

CLIMATE CONTROL

Climate control systems 79
 Air vents 82
 Maintenance 83

CLIMATE CONTROL SYSTEMS Air Conditioning System

Warning

Do not sleep in a vehicle with the air conditioning or heating system on. It may cause serious harm or death due to a drop in the oxygen level and/or body temperature.



Controls for:

- Temperature
- Air distribution
- Fan speed
- Heating
- Demisting and defrosting
- Air recirculation

- Heated rear window

Temperature

Adjust the temperature by turning the knob.

Red : Warm

Blue : Cold

Air distribution

Select air outlet by turning the centered knob.



- ☞ : Bi-level mode: To the face and foot.
- ☞ : Foot mode: To the foot well, with a small amount of the air being directed to windshield, front door windows and side air vents.
- ☞ : Face mode: To the face area.
- ☞ : Demist/Defrost mode: To the windshield and front door windows, with a small amount of the air being directed to side air vents.
- ☞ : Demist/Foot mode: To the windshield and foot well, with a small amount of the air being directed to front door windows and side air vents.

Fan speed



Adjust the air flow by switching the fan to the desired speed.

Demisting windshield



1. Set the recirculation mode to outside air mode and turn the air distribution knob to DEFROST .
2. Switch on cooling .
3. Select desired temperature.
4. Adjust the fan control knob to desired speed.
5. Turn the temperature control knob to the red area for warm air.

Caution

A temperature difference between the outside air and the windshield can make the windshield mist up and reduce your forward vision.
Do not use the floor/defrosting mode () or the defrosting () mode in extremely humid weather when the temperature control is set to blue area. Otherwise accidents can result, leading to vehicle damage and personal injury.

Air Recirculation System



The air recirculation mode is operated with the  lever.

Selects either outside air or recirculated inside air.

Warning

Driving with recirculation mode for prolonged period of time can make you sleepy. Periodically turn to the outside air mode for fresh air.

The exchange of fresh air is reduced in air recirculation mode. In operation without cooling the air humidity increases, so the windows may mist up. The quality of the passenger compartment air deteriorates, which may cause the vehicle occupants to feel drowsy.

Heating

Normal heating

1. Turn temperature control knob to red area for heating.
2. Turn air distribution knob to face or bi-level mode.
3. Turn fan control knob to desired speed.

Maximum heating

Use the maximum heating mode for quick heating of the passenger area.

Do not use it for lengthy periods. It can result in an accident because the interior air may become stale and the windows may fog causing loss of driver's visibility.

To clear the windows, turn the air distribution knob to (☞) and move the recirculation lever to outside air mode to allow fresh air into the vehicle.

For maximum heating:

1. Move recirculation lever to the left for the recirculation mode.
2. Turn temperature control knob all the way to the red area for heating.
3. Turn fan control knob to maximum speed.
4. Turn air distribution knob to face or bi-level mode.

Cooling ☼

Operated with the ☼ button and is functional only when the engine and fan are running.

The air conditioning system cools and dehumidifies (dries) when outside temperature is a little above the freezing point. Therefore condensation may form and drip from under the vehicle.

If no cooling or drying is required, switch the cooling system off to save fuel.

The air conditioning will not operate when the fan control knob is in the off position.

Even though the air conditioning is turned on, the vehicle will produce warm air if the temperature knob is set in the red area.

To turn off the air conditioning system, turn the fan control knob to 0.

Caution

Use only R-134a refrigerant.

Normal cooling

1. Operate the air conditioning system.
2. Turn temperature control knob to blue area for cooling.
3. Turn the air distribution knob to face mode.
4. Adjust the fan control knob to the desired speed.

Maximum cooling

To achieve maximum cooling during hot weather and when your vehicle has been exposed to the sun for a long time:

1. Keep the window open for some time, or run the blower at maximum speed in fresh air mode for 2 minutes.
2. Operate the air conditioning system.
3. Move recirculation lever to the left for the recirculation mode.
4. Turn temperature control knob all the way to the blue area for cooling.
5. Turn fan control knob to highest speed.
6. Turn air distribution knob to face mode.

Caution

Using your air conditioning system while driving up long hills or in heavy traffic can cause the engine to overheat. If the engine coolant temperature warning light indicates that the engine is overheating, turn the air conditioning off. Otherwise your vehicle may be damaged.

AIR VENTS

Adjustable Air Vents

At least one air vent must be open while cooling is on in order to prevent the evaporator from icing up due to lack of air movement.

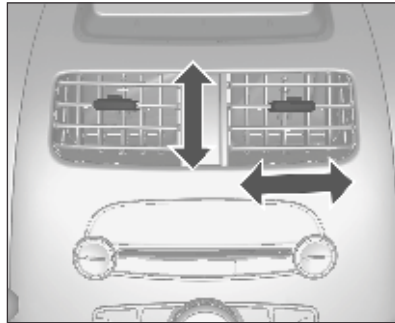

The center vent is not closed completely.

Direct the flow of air by tilting and swiveling the slats.

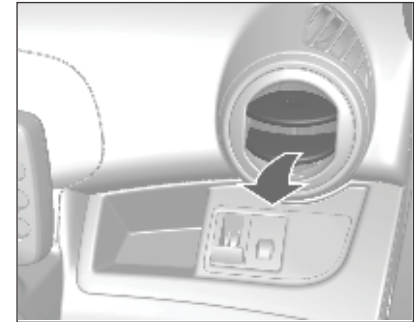

Press the cover of each vent to open the side vents, and rotate it to the direction you want.

If you do not want the flow, close the cover of the vent.

Warning

Do not attach any objects to the slats of the air vents. There is a risk of damage and injury in case of an accident.

Fixed Air Vents

Additional air vents are located beneath the windshield and front door windows and in the foot wells.

MAINTENANCE

Air Intake

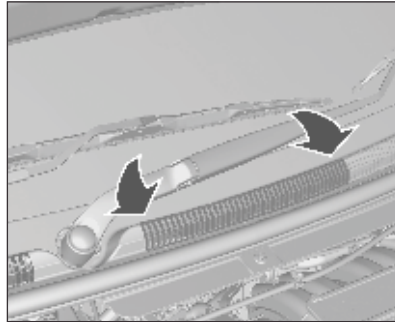

The air intake in front of the windshield in the engine compartment must be kept clear to allow air intake. Remove any leaves, dirt or snow.

Passenger Compartment Air Filter

The filter cleans dust, soot, pollen, spore from the air entering the vehicle through the air intake.

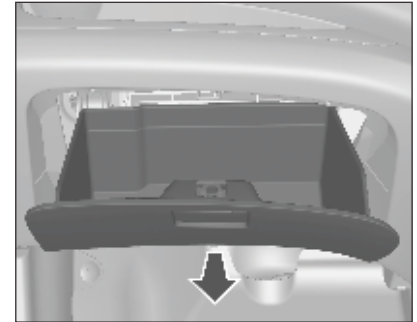

Filter replacement:

1. Remove the glove box.

To remove the glove box, open and pull it up by each side.

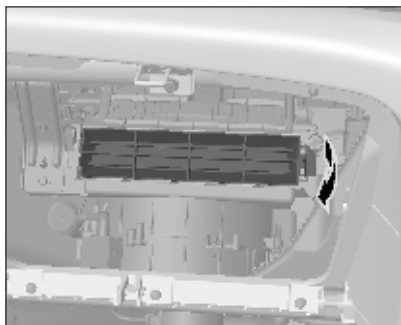

2. Remove the filter cover by pulling right side of the cover.
3. Replace the air conditioner filter.
4. Assemble the filter cover and glove box in reverse order.

Note

We recommend that you consult your authorized CHEVROLET retailer to replace the filter.

Caution

More frequent maintenance of the air filter is required if the driving circumstances are dusty roads, air pollution areas, and frequent unpaved roads.

The filter efficiency is decreased and the bronchus is badly affected.

Air Conditioning Regular Operation

In order to ensure continuously efficient performance, cooling must be operated for a few minutes once a month, irrespective of the weather and time of year. Operation with cooling is not possible when outside temperature is low.

Service

For optimal cooling performance, it is recommended to annually check the climate control system.

- Functionality and pressure test
- Heating functionality
- Leakage check
- Check of drive belts
- Cleaning of condenser and evaporator drainage
- Performance check

Caution

Use only R-134a refrigerant.

Warning

Climate control systems are serviced by qualified personnel only. Improper service methods may cause personal injury.

DRIVING AND OPERATING

Driving information 85
 Starting and operating 87
 Starting the engine88
 Manual transmission 89
 Brakes 90
 Engine exhaust 93
 Fuel 93

DRIVING INFORMATION

Control Of A Vehicle

Never coast with engine not running

Many systems will not function in this situation (e.g. brake servo unit, power steering). Driving in this manner is a danger to yourself and others.

Pedals

To ensure the pedal travel is uninhibited, there must be no mats in the area of the pedals.

Emergency Actions

Caution

Do not operate starter motor for more than 10 seconds at a time.

If the engine does not start, wait 10 seconds before trying again.

This will prevent starter motor damage and battery discharge.

Puncture during driving

When driving, turn on the hazard flashers if a tire is punctured. Hold the steering wheel firmly, lift your foot off the accelerator pedal, and slow the vehicle gradually. Press the brake pedal gently and drive the car into a safe area to change the tire.

Warning

Do not brake suddenly when a tire is punctured. Sudden braking may cause the vehicle to swing to one side and cause accidents.

Faults during driving

When a fault occurs while driving, turn on the hazard flashers. Park the vehicle in a safe area at the roadside.

A warning triangle should be placed behind the vehicle at a distance of 50 m during the day or 100 m at night.

A warning triangle is stored in the rear compartment at the time of vehicle delivery.

Consult your CHEVROLET retailer for inspection and repair.

Caution

Continuing to drive a vehicle with problems may cause accidents.

If the engine does not start

If the ignition switch is in the START position but the starter motor does not work, check the battery for charge, battery terminals are connected properly and concern fuse is blown out.

If the starter motor works but the engine does not start, check the oil level, the fuel filter, the fuel pump, the associated wiring, etc.

The fuel pump can be checked by listening to the sound when the ignition switch is turned ON.

Measures to be taken when the engine is over heated

While driving, if a sudden drop in power or the temperature warning light comes on, park the vehicle in a safe place and take the following measures.

- Run the engine at idle and then move the gear shift lever into neutral.
- Apply the parking brake.
- Turn off the air conditioning.
- Open the hood to ventilate the engine compartment.

⚠ Warning

If steam or coolant escapes from the engine, do not open the hood, otherwise you may be scalded by the steam or coolant.

- If the coolant level does not drop while the engine is idling, switch off the engine to let it cool down.

- If the cooling fan does not work, switch off the engine to let it cool down.
- If the coolant level is too low, open the cap and fill the coolant tank with coolant very slowly.

Caution

Sudden filling of coolant into an over heated engine will damage the engine.

Caution

Do not open the coolant cap when the engine is hot else steam or coolant will escape and scald your face or body. Wait until the engine is completely cooled before opening the coolant cap.

Cover the coolant cap with a cloth, open it a little (1/2 turn) at first, and do not open it completely until the pressure inside has been released.

- After taking temporary measures, seek assistance from your CHEVROLET retailer for inspection and necessary repairs.

In case of fire

A fire might be caused by unauthorized changes to the electrical and fuel system or by accidents. Keep a fire extinguisher inside your vehicle.

No fire extinguisher is provided at the time of vehicle delivery.

Warning

The fire will soon spread to other parts of the car as the vehicle contains many combustible materials such as various oils, fibers, and plastics.

All passengers should immediately exit the vehicle and reach to a safe area.

Do not change the electrical or fuel systems without authorization, or a fire might be caused.

Use in the snow

- Slow down when turning a corner, driving uphill or crossing a bridge.
- Do not park the car on a hard verge or it may obstruct the snow clearing work.
- Keep a safe distance from other cars; avoid unnecessary braking.
- Frequent cleaning of the snow surrounding the vehicle can protect the exhaust pipe from being blocked.

STARTING AND OPERATING

New Vehicle Break - In

Use the following precautions for the first few hundred kilometers to improve the performance and economy of your vehicle and add to its long life:

- Avoid full throttle starts.
- Allow the engine to warm up before driving.
- Do not race the engine.
- Avoid hard stops except in emergencies. This will allow your brakes to bed in properly.
- Avoid quick starts, sudden accelerations, and prolonged highspeed driving in order to avoid damage to the engine and to conserve fuel.
- Avoid full-throttle acceleration in low gear.
- Do not tow any other vehicle.

Ignition Switch Positions

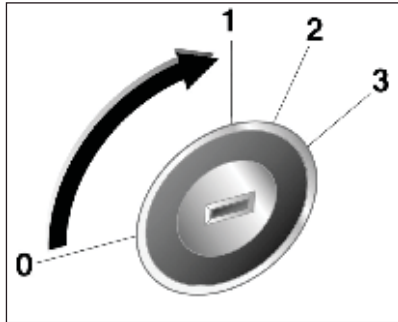

- 0 (LOCK)** : Ignition off
- 1 (ACC)** : Ignition off, steering wheel lock released
- 2 (ON)** : Ignition on
- 3 (START)** : Starting

▲ Warning

Do not turn the key to **0** or **1** position while driving.

Vehicle and brake assistance would not operate, causing vehicle damage, personal injury or possibly death.

Caution

Do not leave the key in **1** or **2** position for extended periods while the engine is not running.

This will discharge the battery.

STARTING THE ENGINE

Starting Engine With The Ignition Switch

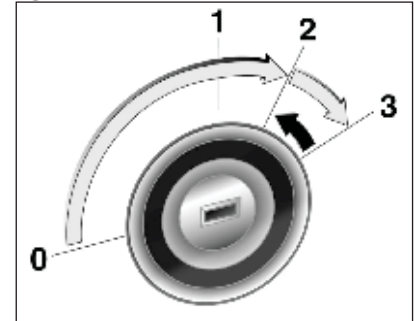

- Turn key to position **1**, move the steering wheel slightly to release the steering wheel lock
- Manual transmission: operate clutch
- Do not accelerate
- Turn the key to position **3**, depressing the clutch pedal and footbrake then release when engine is running

Before restarting or to switch off the engine, turn key back to **1** or **0**.

Caution

Do not operate starter motor for more than 10 seconds at a time.

If the engine does not start, wait 10 seconds before trying again.

This will prevent starter motor damage.

Caution

Do not idle the engine at high rpm for more than 3 minutes.

Excessive temperature can damage the exhaust system / catalytic converter.

Caution

Do not operate the key through the steering wheel.

Otherwise the steering wheel may turn suddenly, causing the driver to lose control over the vehicle and lead to vehicle damage and injury.

Parking

- Do not park the vehicle on an easily ignitable surface. The high temperature of the exhaust system could ignite the surface.
- Always apply parking brake without pressing release button. Apply as firmly as possible on downhill or uphill slopes. Depress the footbrake at the same time to reduce operating force.
- Switch off the engine and ignition. Turn the steering wheel until the steering wheel lock engages.
- If the vehicle is on a level surface or uphill slope, engage first gear before switching off the ignition. On an uphill slope, turn the front wheels away from the kerb. If the vehicle is on a downhill slope, engage reverse gear before switching off the ignition. Turn the front wheels towards the kerb.
- Close the windows.
- Lock the vehicle.

MANUAL TRANSMISSION

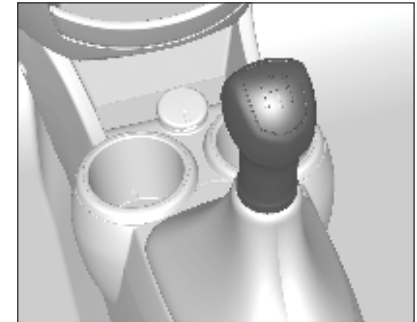

If the gear does not engage, set the lever in neutral, release the clutch pedal and depress again; then repeat gear selection.

Do not grind the clutch unnecessarily. When operating, depress the clutch pedal completely. Do not use the pedal as a foot rest.

Caution

It is inadvisable to drive with hand resting on the selector lever.

BRAKES

The brake system comprises two independent brake circuits.

If a brake circuit fails, the vehicle can still be braked using the other brake circuit. However, braking effect is achieved only when the brake pedal is depressed firmly. Considerably more force is needed for this. The braking distance is extended. Seek the assistance of a CHEVROLET retailer before continuing your journey.

Caution

If one of the circuits fail, the brake pedal must be pressed with greater pressure and the braking distance may be increased. Have the brake system checked and repaired by a CHEVROLET retailer immediately.

If the brake pedal can be pressed further than normal, the brakes may be in need of repair.

Consult a CHEVROLET retailer immediately.

Caution

Do not drive with your foot resting on the brake pedal. Doing so will accelerate wear of the brake components. The brakes may also become overheated, resulting in longer braking distance and an unsafe condition.

⚠ Warning

After driving through deep water, washing the vehicle, or using the brakes excessively when going down a steep hill, the brakes can temporarily lose their stopping power. This may be due to wet brake components or overheating.

If your brakes temporarily lose their stopping power because of overheating: Shift to a lower gear when going down hills. Do not continuously apply the brakes.

⚠ Warning

If your brakes temporarily lose their power because of wet brake components, the following procedure will help restore their normal performance:

1. Check behind you for other vehicles.
2. Keep a safe forward speed with plenty of space to your rear and sides.
3. Gently apply the brakes until normal performance is restored.

Antilock Brake System (ABS)*

Antilock brake system (ABS) prevents the wheels from locking.

ABS starts to regulate brake pressure as soon as a wheel shows a tendency to lock. The vehicle remains steerable, even during hard braking.

ABS control is made apparent through a pulse in the brake pedal and the noise of the regulation process.

For optimum braking, keep the brake pedal fully depressed throughout the braking process, despite the fact that the pedal is pulsating. Do not reduce the pressure on the pedal.

The ABS control can be known by vibration and noise of the ABS process.

See *Antilock brake system (ABS) warning light* on page 60.

Caution

ABS will not change the time needed for braking, neither it will necessarily shorten the braking distance. Even if ABS is equipped, an adequate braking distance should be maintained.

Fault

Warning

If there is a fault in the ABS, the wheels may be liable to lock due to braking that is heavier than normal. The advantages of ABS are no longer available. During hard braking, the vehicle can no longer be steered and may swerve.

Have the cause of the fault remedied by a CHEVROLET retailer.

Using ABS

Do not pump the brakes. Just hold the brake pedal down firmly and let ABS work. You might hear the ABS pump or motor operating and feel the brake pedal pulsate, but this is normal.

Braking In Emergencies

ABS allows the driver to steer and brake at the same time. In many emergencies, steering can help more than even the very best braking.

Brake Assist

If the brake pedal is depressed quickly and forcefully, maximum brake force is automatically applied (full braking).

Maintain steady pressure on the brake pedal for as long as full braking is required. Maximum brake force is automatically reduced when the brake pedal is released.

Parking Brake

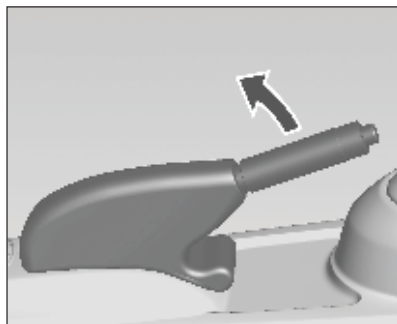

Always apply parking brake firmly without operating the release button, and apply as firmly as possible on a downhill or uphill slope.

To release the parking brake, pull the lever up slightly, press the release button and fully lower the lever.

To reduce the operating forces of the parking brake, depress the foot brake at the same time.

See *Brake system warning light* on page 60.

Warning

If the parking brake is not set properly, the vehicle may move suddenly. See your CHEVROLET retailer if an adjustment is required.

Caution

Do not drive with the parking brake on.

This can cause your rear brakes to overheat or wear out prematurely. You may have to replace them, and you could damage other parts of your vehicle.

Caution

Do not park or operate your vehicle over combustible materials.

They could touch hot exhaust parts under your vehicle and ignite.

ENGINE EXHAUST

Danger

Engine exhaust gases contain poisonous carbon monoxide, which is colourless and odourless and could be fatal if inhaled.

If exhaust gases enter the interior of the vehicle, open the windows. Have the cause of the fault rectified by a CHEVROLET retailer.

Avoid driving with an open load compartment, otherwise exhaust gases could enter the vehicle.

Catalytic Converter

The catalytic converter reduces the amount of harmful substances in the exhaust gas.

Caution

Fuel grades other than those listed on pages *Fuel for petrol engines* on page 93, could damage the catalytic converter or electronic components.

Unburnt petrol will overheat and damage the catalytic converter. Therefore avoid excessive use of the starter, running the fuel tank dry and starting the engine by pushing or towing.

In the event of misfiring, uneven engine running, a reduction in engine performance or other unusual problems, have the cause of the fault rectified by a CHEVROLET retailer as soon as possible. In an emergency, driving can be continued for a short period, keeping vehicle speed and engine speed low.

FUEL

Fuel For Petrol Engines

Only use unleaded fuel that complies with DIN EN 228.

Equivalent standardised fuels with an ethanol content of max. 10% by volume may be used.

Use fuel with the recommended octane rating. See *Engine data* on page 140. Use of fuel with too low an octane rating can reduce engine power and torque and slightly increases fuel consumption.

Caution

Use of fuel with too low an octane rating could lead to uncontrolled combustion and engine damage.

Filling The Tank

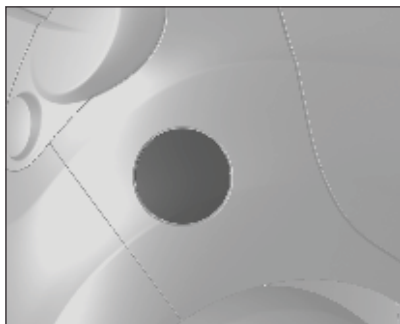

Caution

If you use inappropriate grade fuel or put incorrect fuel additives into the fuel tank, the engine and catalytic converter may seriously be damaged.

Caution

Be sure to use the correct fuel corresponding to your vehicle when refueling. If you fill incorrect fuel, your vehicle can be seriously damaged. You can confirm the correct fuel by taking a look at information on the fuel filler door.

For safety reasons, fuel containers, pumps and hoses must be properly earthed. Static electricity build up can ignite the petrol vapor. You can be burnt and your vehicle damaged.

⚠ Danger

Before refueling, switch off engine and any external heaters with combustion chambers. Switch off any mobile phone.

Vaporized fuel can be ignited by electromagnetic waves or current of mobile phone.

Fuel is flammable and explosive. No smoking. No naked flames or sparks. Follow the operating and safety instructions of the filling station when refueling.

Remove static electricity on your hands by touching something able to release static electricity when touching or opening fuel cap or refueling nozzle.

Don't do any action making static electricity like getting on and off vehicle when refueling. Vaporized fuel can be ignited by static electricity.

⚠ Danger

If you can smell fuel in your vehicle, have the cause of this remedied immediately by a CHEVROLET retailer.



1. Stop the engine.
2. Pull up on fuel filler door release lever located on the floor, right front side of driver's seat.
3. Turn the fuel filler cap counter-clockwise slowly. If a hissing sound is heard, wait for it to stop before

completely unscrewing the cap. The fuel filler door is in the right rear quarter panel.

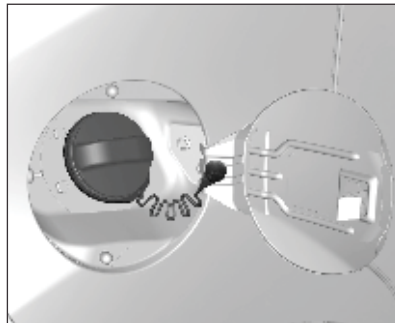

4. Remove the cap. The cap is tethered to the vehicle.
5. After refueling, refit cap. Turn it clockwise until you hear several clicks.
6. Push the fuel filler door closed until it latches.

Note

If, in cold weather, the fuel filler door does not open, tap the door lightly. Then try to open it again.

Caution

Wipe off any overflowing fuel immediately.

VEHICLE CARE

General information 97
 Vehicle checks 98
 Engine compartment overview 101
 Bulb replacement 109
 Electrical system 115
 Vehicle tools 120
 Wheels and tires 120
 Jump starting 127
 Towing 128
 Appearance care 130

GENERAL INFORMATION

Accessories And Modifications

We recommend to use genuine parts and accessories and factory approved parts specific for your vehicle type. We cannot assess or guarantee for other products - even if they have a regulatory or otherwise granted approval.

Do not make any modifications to the electrical system, e.g. changes of electronic control units (chip tuning).

Caution
<p>Never modify your vehicle. It may affect the performance, durability and safety of the vehicle and the warranty may not cover any problems caused by the modification.</p>

Vehicle Storage

Storage for a long period of time

If the vehicle is to be stored for several months:

- Wash and wax the vehicle.
- Have the wax in the engine compartment and underbody checked.
- Clean and preserve rubber seals.
- Change engine oil.
- Drain washer fluid reservoir.
- Check coolant anti-freeze and corrosion protection.
- Adjust tire pressure to the value specified.
- Park vehicle in dry, well ventilated place. Engage first or reverse gear. Prevent the vehicle from rolling.
- Do not apply parking brake.
- Open hood, close all doors and lock the vehicle.
- Disconnect the clamp from the negative terminal of the vehicle battery. Beware that all systems are

not functional, e.g. anti-theft alarm system.

- Close the hood.

Putting back into operation

When the vehicle is to be put back into operation:

- Connect the clamp to the negative terminal of the vehicle battery. Activate the electronic of the power windows.
- Check tire pressure.
- Fill up the washer fluid reservoir.
- Check the engine oil level.
- Check the coolant level.
- Fit the number plate if necessary.

Radio Frequency Identification (RFID) Tag *

This vehicle is equipped with Radio Frequency Identification (RFID) tag*, which can be used for Electronic Toll Collection (ETC) or any other applications as decided by the Regulatory authority. The RFID tag is located on inside the windshield. Data for necessary applications will be added by the agency authorized by the Regulatory authority, from time to time. Take proper care during washing or cleaning of windshield so as to avoid any damage to the RFID tag. In case of any damage or malfunction of RFID tag, or in case of windshield replacement, contact your CHEVROLET retailer or agency authorized by the Regulatory authority for the installation of new RFID tag.

Caution

Do not touch or peel off. Do not place any sticker or other metallic components over the RFID tag neither from inside nor from outside of the windshield. Avoid exposure to chemicals or liquid solvents. This will impair the function of RFID tag. The RFID tag is tamperproof and will not function once removed from windshield.

VEHICLE CHECKS

Doing Your Own Service Work

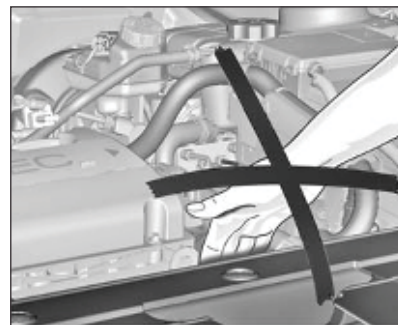

⚠ Warning

Only perform engine compartment checks when the ignition is off.

The cooling fan may start operating even if the ignition is off.

⚠ Warning

The ignition system uses extremely high voltage. Do not touch.

Hood Opening

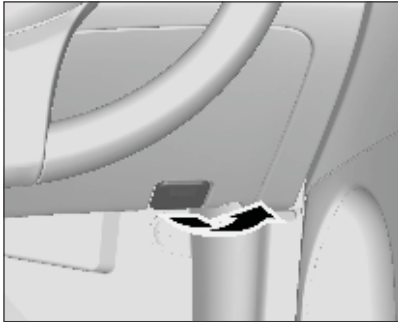

1. Pull the release lever and return it to its original position.

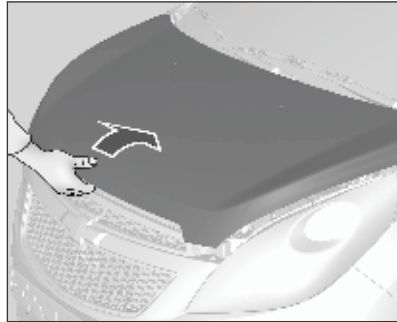

2. Push the safety latch to the up and open the hood.

⚠ Warning

When the engine is hot, only touch the foam padding of the hood support rod handle .

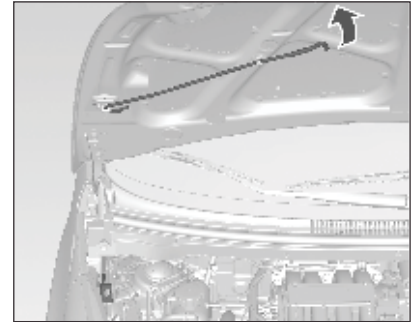

3. Pull up the support rod lightly from the holder.

And then secure it at the left side hook of the engine compartment.

Closing

Before closing the hood, press the support into the holder.

Lower the hood and allow it to drop into the latch. Check that the hood is engaged.

▲ Warning

Always observe the following precautions:

Pull on the front edge of the hood to make sure it is latched securely before you drive your vehicle.

Do not pull the hood release lever while your vehicle is moving.

Do not move your vehicle with the hood open. An open hood will obscure the driver's vision.

Operating your vehicle with the hood open can lead to a collision resulting in damage to your vehicle, to other property, personal injury or even death.

Suggestions For More Economical Operation

Fuel economy is dependent largely on your style of driving.

How you drive, where you drive and when you drive affect how many kilometers you can get from a litre of fuel.

To obtain maximum fuel economy:

- Accelerate slowly.
- Avoid unnecessary idling.
- Keep the engine properly tuned.
- Do not race the engine.
- Use the air conditioning only when necessary.
- Slow down when driving on rough roads.
- Keep the tires inflated to the recommended pressure.
- Maintain a safe distance from other vehicles to avoid a collision in case of sudden stops. This will also reduce wear on the brake pads and linings.
- Do not carry unnecessary weight.
- Do not rest your foot on the brake pedal while driving and follow the maintenance schedule.

Hazardous Driving

When hazardous driving is encountered due to water, snow, ice, mud, sand, or similar conditions:

- Slow down your vehicle and drive cautiously allowing extra distance for braking.
- Avoid sudden manoeuvres when braking, steering or accelerating.
- When braking, press the brake pedal with a light, up-and-down motion until the vehicle is stopped (Unless equipped with ABS).
- If stuck in snow, mud or sand, use second gear to avoid spinning of front wheels.

ENGINE COMPARTMENT OVERVIEW

Petrol Engine

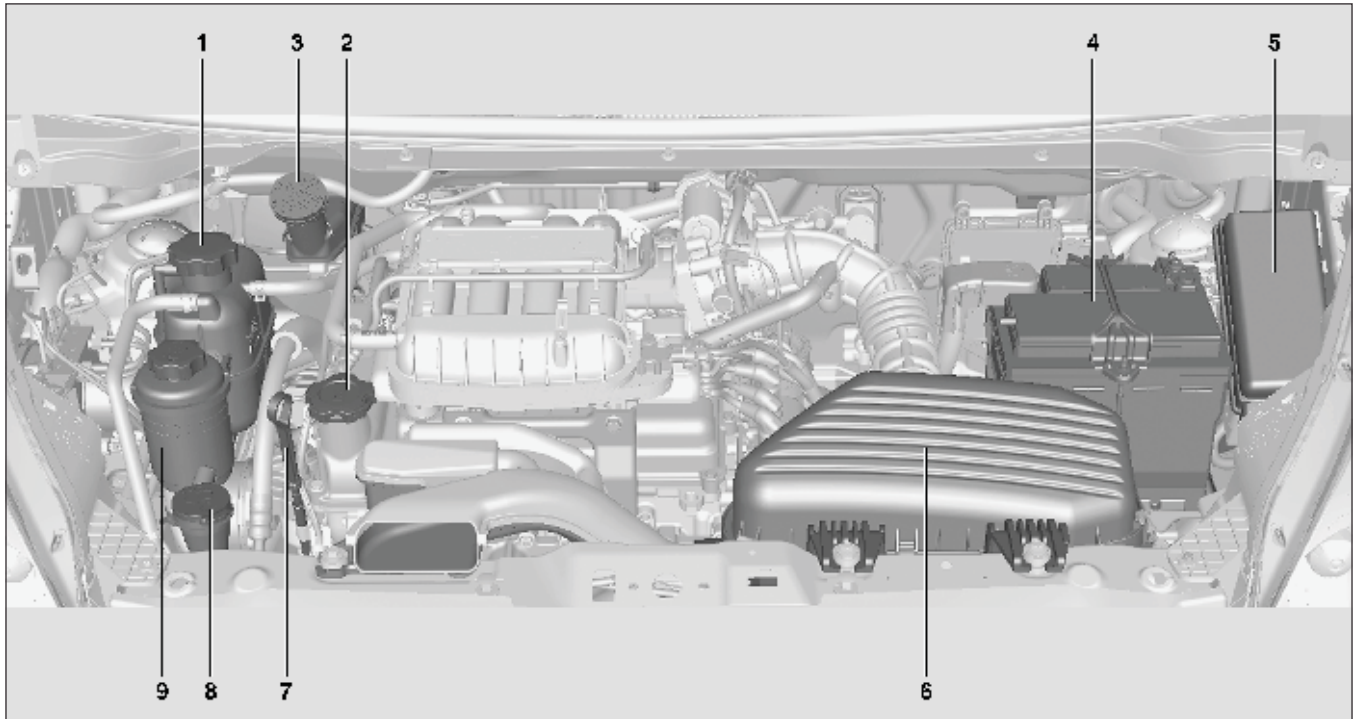

1. Engine coolant container
2. Engine oil cap
3. Brake fluid container
4. Battery
5. Engine compartment fuse block
6. Engine air filter
7. Engine oil level dipstick
8. Washer fluid container
9. Power steering fluid container

Engine Oil

It is advisable to check the engine oil level manually before embarking on a long journey.

Check with the vehicle on a level surface. The engine must be at operating temperature and switched off for at least 20 minutes.

Pull out the dipstick, wipe it clean, insert it to the stop on the handle, pull out and read the engine oil level.

Insert dipstick to the stop on the handle and make half a turn.

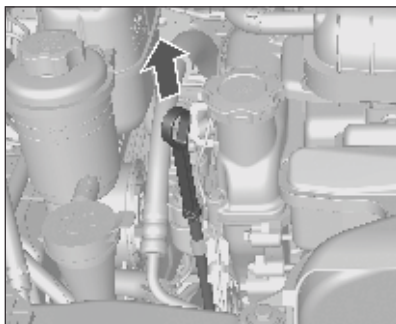

When the engine oil level has dropped to the MIN mark, top up engine oil.

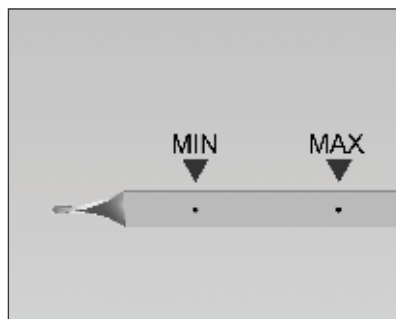

We recommend the use of the same grade of engine oil that was used at last change.

The engine oil level must not exceed the MAX mark on the dipstick.

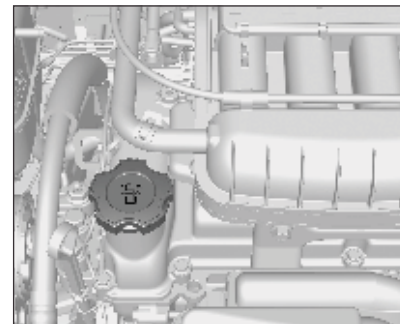

The engine oil filler cap is located on the camshaft cover.

Caution

Overfilled engine oil must be drained or suctioned out.

See *Capacities and Specifications* on page 142.

Caution

Overfilling the engine with oil may affect the operation of engine. The upper limit mark on the dipstick must not be exceeded. Overfilling may damage the vehicle, because:

- The engine oil consumption will be increased.
- Excessive carbon accumulation on the engine.

Caution

Using engine oils of a viscosity other than recommended could result in engine damage and repair not covered under warranty.

Caution

Use of unauthorized or low quality engine oil could damage the engine.

⚠ Warning

Engine oil is an irritant and, if ingested, can cause illness or death. Keep out of reach of children. Avoid repeated or prolonged contact with skin. Wash exposed areas with soap and water or hand cleaner. Be very careful when draining the engine oil as it may be hot enough to burn you!

Engine Air Filter

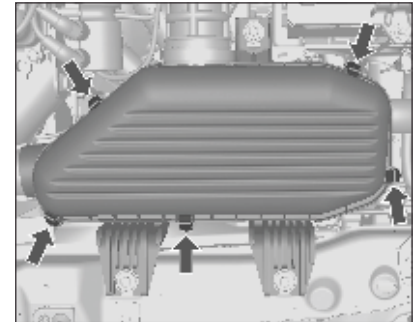

1. Loosen the air filter cover attaching clips and open the cover.
2. Replace the air filter.
3. Lock the cover with the cover attaching clips.

Caution

The engine needs clean air to operate properly.

Do not operate your vehicle without the air cleaner element installed.

Driving without the air cleaner element properly installed can damage your engine.

Engine Coolant

In countries with moderate climate the coolant provides freeze protection down to approx. -25°C.

Maintain a sufficient concentration of anti-freeze.

Caution

Only use approved anti-freeze.

Coolant level

Caution

Too low a coolant level can cause engine damage.

Caution

Plain water or the wrong mixture can damage the cooling system.

Do not use plain water, alcohol or methanol anti-freeze in cooling system.

The engine may overheat or even catch fire.

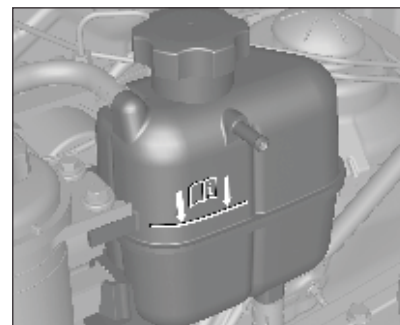

If the cooling system is cold, the coolant level should be above the filling line mark. Fill up if the level is low.

⚠ Warning

Allow the engine to cool before opening the cap. Carefully open the cap, relieving the pressure slowly.

Fill up with a mixture of demineralised water and anti-freeze approved for the vehicle. Install the cap tightly. Have the anti-freeze concentration checked and have the cause of the coolant loss remedied by a CHEVROLET retailer.

Note

If the coolant level falls below the line mark, refill the coolant reservoir with recommended coolant available with your CHEVROLET retailer.

⚠ Warning

Steam and scalding liquids from a hot cooling system can blow out and burn you badly. They are under pressure, and if you turn the coolant surge tank pressure cap—even a little—they can come out at high speed. Never turn the cap when the cooling system, including the coolant surge tank pressure cap, is hot. Wait for the cooling system and coolant surge tank pressure cap to cool if you ever have to turn the pressure cap.

Caution

Coolant can be hazardous material. Avoid repeated or prolonged contact with coolant.

Clean your skin and nails with soap and water after coming in contact with coolant.

Keep out of reach of children.

Coolant can irritate the skin and can cause illness or death if swallowed.

Caution

It is not needed to add coolant more frequently than the recommended interval.

If you are adding coolant often, this may be a sign that your engine needs maintenance.

Contact a CHEVROLET retailer for a check of the cooling system.

Power Steering Fluid

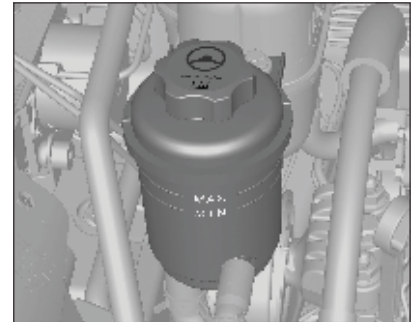

Open the cap and remove it.

The power steering fluid level must be between the MIN and the MAX marks.

Fill up if the level is low.

Caution

Do not operate vehicle without the required amount of power steering fluid.

Doing so can damage power steering system of your vehicle, leading to costly repairs.

Warning

An overflow of the fluid may cause the fluid to burn or discolor paintwork.

Do not overfill the reservoir.

An engine fire can cause personal injuries and damage your vehicle and other property.

Washer Fluid

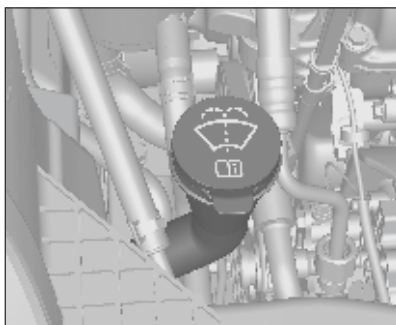

Fill with windshield washer fluid that contains anti-freeze.

To refill windshield washer fluid reservoir:

- Use only commercially available ready-to-use washer fluid for that purpose.
- Do not use tap water. Minerals present in tap water may plug the windshield washer lines.
- If air temperature is likely to go below freezing, use windshield washer fluid which has sufficient anti-freezing property.

Brake Fluid

Warning

Brake fluid is poisonous and corrosive. Avoid contact with eyes, skin, fabrics and painted surfaces.

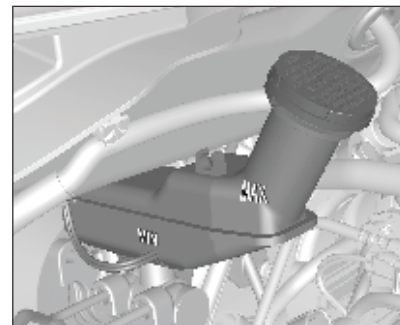

The brake fluid level must be between the MIN and the MAX marks.

When filling up, ensure maximum cleanliness as contamination of the brake fluid can lead to brake system malfunctions. Have the cause of the loss of brake fluid remedied by a CHEVROLET retailer.

Only use brake fluid approved for the vehicle.

See "Brake Fluid" under *Recommended fluids and lubricants* on page 138.

Caution

Make sure you thoroughly clean around the brake fluid reservoir cap before removing the cap.
Contamination of the brake fluid system can affect system performance, leading to costly repairs.

Caution

An overflow of brake fluid on the engine may cause the fluid to burn.
Do not overfill the reservoir.
An engine fire can cause personal injuries and damage your vehicle and other property.

Caution

Do not dispose of used brake fluid with your household waste.
Use your local, authorized waste management facility.
Used brake fluid and their containers are hazardous. They can damage your health and the environment.

Caution

Brake fluid is harsh and can irritate skin and eyes.
Do not allow the brake fluid to contact your skin or eyes. If it does, immediately wash the affected area thoroughly with soap and water, or hand cleaner.

Battery

The vehicle battery is maintenance free. Batteries do not belong in household waste. They must be disposed of at an appropriate recycling collection point.

Laying up the vehicle for more than 4 weeks can lead to battery discharge. Disconnect the clamp from the negative terminal of the vehicle battery.

Ensure the ignition is switched off before connecting or disconnecting the vehicle battery.



⚠ Warning

Keep smoking materials away from a battery to avoid flames or sparks when the battery is checked because the explosive gas could be occurred.

If the battery explodes, it can be result in damages of your vehicle and serious injury or death.

Avoid skin contact with battery acid because it can cause damage by contained highly corrosive and toxic sulfuric acid.

If you accidentally get it on your skin, flush the place with water and get medical help immediately.

Keep batteries out of the reach of children because it contains sulfuric acid and gas.

Do not allow battery acid to contact your skin, eyes, clothing or paint.

Do not open and tilt the battery.

See *Battery power protection* on page 68.

Wiper Blade Replacement

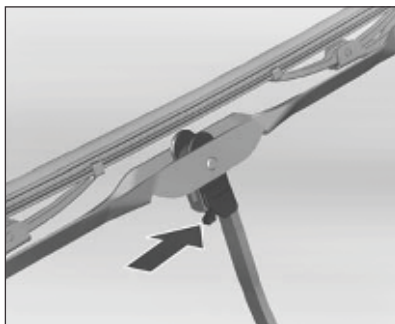

Lift wiper arm. Press release lever and detach wiper blade.

Properly functioning windshield wipers are essential for clear vision and safe driving. Regularly check the condition of the wiper blades.

Replace hard, brittle or cracked blades or those that smear dirt on the windshield.

Foreign material on the windshield or wiper blades can reduce the effectiveness of the wipers. If the blades are not wiping properly, clean both the windshield and the blades with a good cleaner or mild detergent. Rinse them thoroughly with water. Repeat the process, if necessary.

There is no way to remove traces of silicone from glass. Therefore, never apply polish with silicone to your vehicle's windshield or you will get streaks which will impair the driver's vision.

Do not use solvents, gasoline, kerosene, or paint thinner to clean wipers. These are harsh and can damage the blades and painted surfaces.

BULB REPLACEMENT

Switch off the ignition and switch off the relevant switch or close the doors.

Only hold a new bulb at the base! Do not touch the bulb glass with bare hands.

Use only the same bulb type for replacement.

Replace headlamp bulbs from within the engine compartment.

Note

After driving in heavy rain or washing, some exterior lamp lenses could appear frosty.

This condition is caused by the temperature difference between the lamp inside and outside.

This is similar to the condensation on your windows inside your vehicle during the rain and doesn't indicate a problem with your vehicle.

If the water leaks into the lamp bulb circuitry, have the vehicle checked by your CHEVROLET retailer.

Headlamp And Parking Lamps

Low beam and high beam

1. Detach plug connector from bulb.

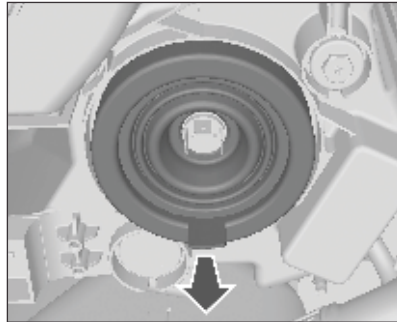

2. Remove protective cover.

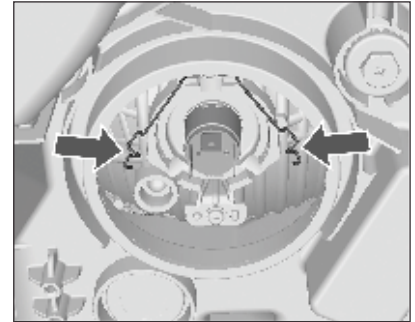

3. Press spring clip, disengage it.

Warning

The same rating of the bulb to be used during replacement and any usage of higher wattage bulbs can cause thermal issues such as melting of lamp housing and its surrounding parts. Warranty would be void if higher wattage bulbs are being used.

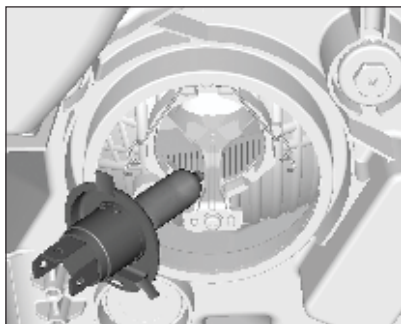

4. Remove bulb from reflector housing.
5. When fitting a new bulb, engage the lugs in the recesses on the reflector.
6. Engage the spring clip.
7. Place headlamp protective cover in position and close.
8. Plug connector onto bulb.

Headlamp aiming

The screw located above the headlamp is to adjust low-beam headlamp aiming.

Caution

If the headlamps need to be re-aimed, it is recommended that the vehicle is taken to your CHEVROLET retailer for service because it is related with safety.

Parking lamps

1. Detach plug connector from bulb.

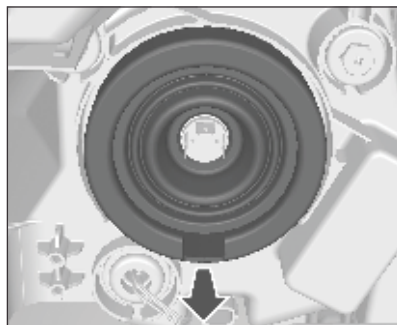

2. Remove protective cover.



3. Remove parking lamp bulb holder from reflector.

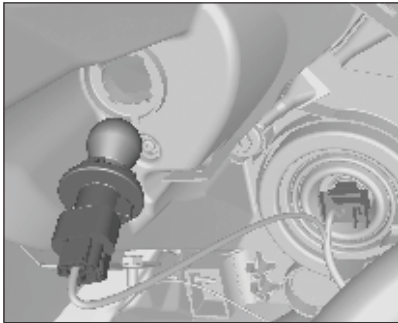

4. Remove bulb from socket.
5. Insert new bulb.
6. Insert holder in reflector.
7. Place headlamp protective cover in position and close.
8. Plug connector onto bulb.

Fog Lamps

Have bulbs replaced by a CHEVROLET retailer.

Foglamp Aiming

The fog lamp aiming can be adjusted with the screw located above the fog lamp.

Caution

If the fog lamps need to be re-aimed, it is recommended that the vehicle is taken to your authorized CHEVROLET retailer for service because it is related with safety.

Front Turn Signal Lamps

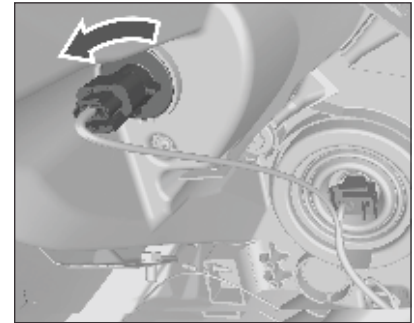

1. Rotate bulb holder anti-clockwise and disengage.

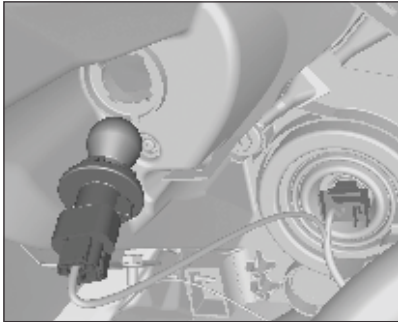

2. Push bulb into socket slightly, rotate anti-clockwise, remove and renew bulb.
3. Insert bulb holder in reflector, rotate clockwise to engage.

Taillamps, Turn Signal, Stoplamp And Back-Up Lamps

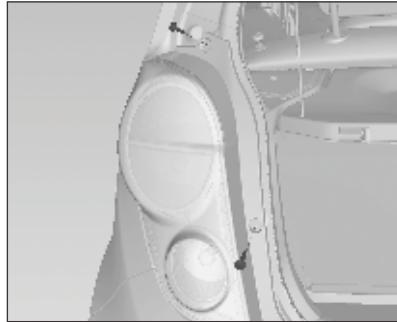

1. Unscrew both screws.
2. Remove tail light assembly. Take care that the cable duct remains in position.

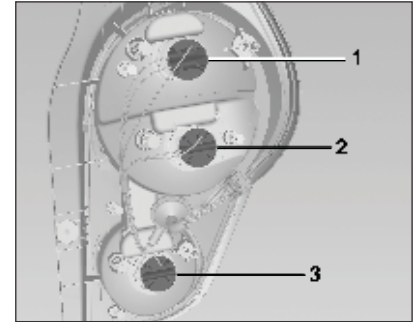

3. Taillamp/Stoplamp (1), Turn signal lamp (2), Back-up lamp (3).

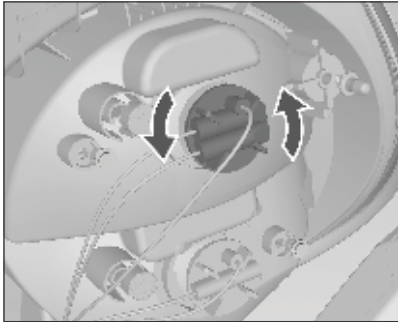

4. Rotate bulb holder anti-clockwise.

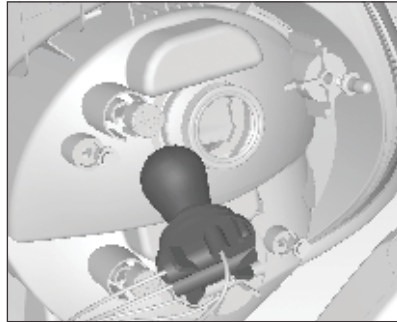

5. Remove bulb holder. Push bulb into socket slightly, rotate anticlockwise, remove and renew bulb.
6. Insert bulb holder into the tail light assembly and screw into place. Connect wiring plug. Install tail light assembly in body and tighten screws. Close covers and engage.
7. Switch on ignition, operate and check all lights.

Side Turn Signal Lamps

1. Push light towards the back of the vehicle and remove.
2. Rotate bulb holder anti-clockwise.
3. Pull bulb out of the bulb holder and renew.
4. Reinstall in reverse order.

Center High-Mounted Stop Lamp (CHMSL) Bulb Type CHMSL

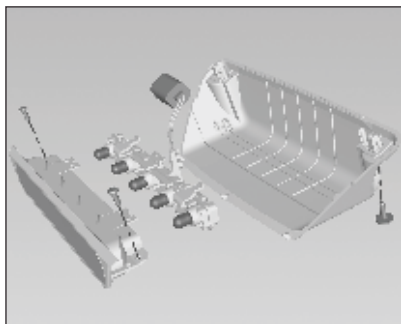

1. Open the tailgate.
2. Remove the two screws and the lamp housing. Disconnect the wiring harness connector before removing the lamp housing.
3. Remove the two screws and the reflector assembly.
4. Remove the bulb by pulling it straight out of the bulb holder.
5. Install a new bulb.
6. Reinstall the lamp housing.

LED Type CHMSL*

Have the bulbs replaced by the CHEVROLET retailer.

License Plate Lamp

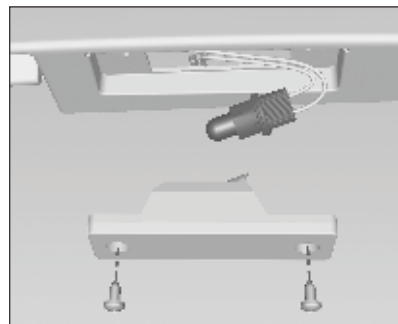

1. Unscrew both screws.
2. Remove bulb housing downward, taking care not to pull on the cable. Rotate bulb holder anti-clockwise to disengage.
3. Remove bulb from holder and renew bulb.
4. Insert bulb holder in bulb housing and rotate clockwise.
5. Insert bulb housing and secure using a screwdriver.

Interior Lamps

Courtesy lamps

1. To remove it, pry the opposite side of the lamp switch using a flat-blade screwdriver. (Be careful not to make scratches.)
2. Remove the bulb.
3. Replace the bulb.
4. Reinstall the lamp assembly.

ELECTRICAL SYSTEM

Fuses

Data on the replacement fuse must match the data on the defective fuse.

Before replacing a fuse, turn off the respective switch and the ignition.

A blown fuse can be recognised by its melted wire (as shown below). Do not replace the fuse until the cause of the fault has been remedied. Seek the assistance of your CHEVROLET retailer for service.

Some functions are protected by several fuses.

Fuses may also be inserted without existence of a function.

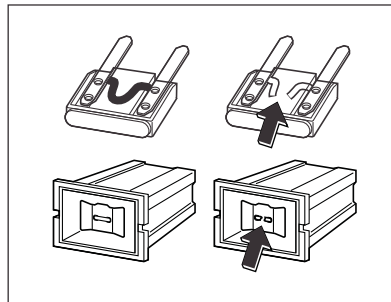

Fuse Extractor

A fuse extractor may be located in the fuse box in the engine compartment.

Place the fuse extractor on the various types of fuse from the top or side, and withdraw fuse.

Engine Compartment Fuse Block

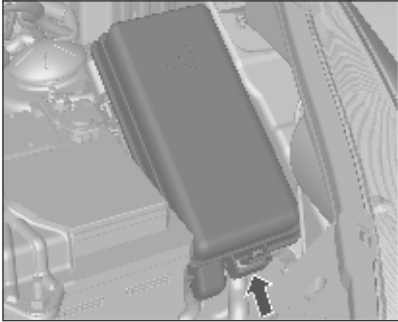

The fuse box is in the engine compartment.

Disengage the cover, lift it upwards and remove.

Note

Not all fuse box descriptions in this Manual may apply to your vehicle.

When inspecting the fuse box, refer to the fuse box label.

Engine Compartment Fuse Box - Underhood

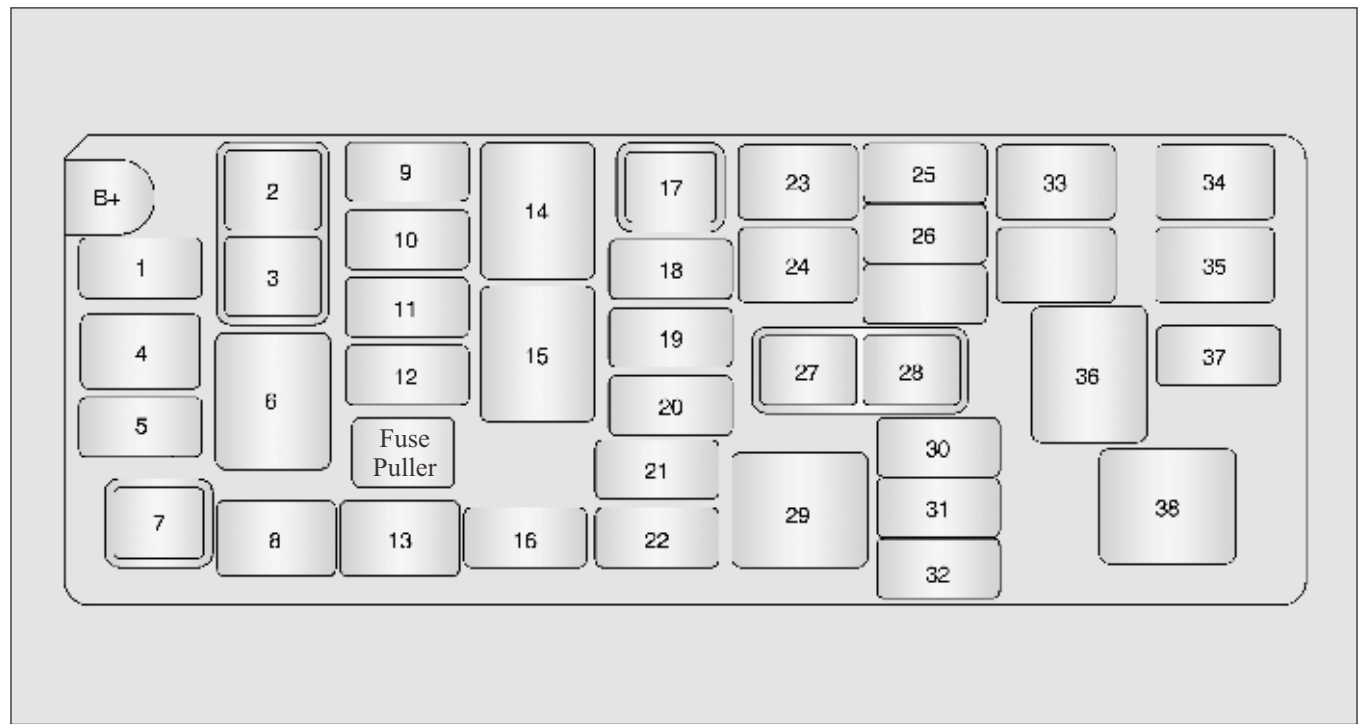

1. Fuel pump
2. Parking lamp relay
3. Fan low relay
4. Fan high
5. Air condition
6. Fan high relay
7. Air condition relay
8. ABS2
9. Park LH
10. Park RH
11. Front fog
12. Fan low
13. ABS1
14. Front fog relay
15. Fuel pump relay
16. Spare fuse
17. Headlamp high relay
18. Headlamp high
19. Headlamp low LH
20. Headlamp low RH
21. Spare fuse
22. Spare fuse
23. Ignition2/starter
24. Ignition1/accessory
25. Hazard warning flashers
26. Horn
27. Headlamp low relay
28. Horn relay
29. Engine main relay
30. Ignition
31. EMS1
32. EMS2
33. Instrument panel battery
34. EVP (LPG)
35. Heated seat
36. Heated seat relay
37. Engine control module
38. EVP relay (LPG)

Instrument Panel Fuse Block



Instrument panel fuse block is located on the underside of the driver's side instrument panel.

Fuse Box - Instrument Panel

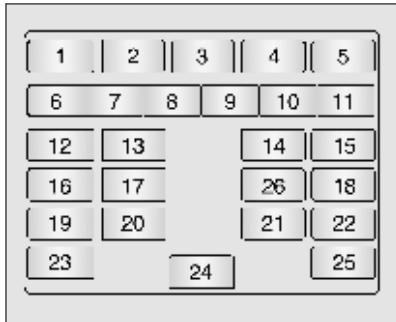

1. Rear wiper
2. Mirror/outside rear view mirror
3. Headlamp
4. Electric OSRVM
5. Door lock
6. Front wiper
7. Spare fuse
8. Backup lamps
9. Turn signals
10. Rear defogger
11. Rear fog lamps
12. Instrument cluster
13. Blower motor control module
14. Airbag
15. Theft deterrent/data link connector
16. Transmission control module
17. Rear power windows
18. Radio/remote keyless entry/remote entry
19. Engine control module(ECM)/ theft deterrent
20. Front power windows
21. Cigarette lighter
22. Stop lamp
23. Starter
24. Radio/ clock/ remote keyless entry
25. Cluster/ interior lamps
26. -

VEHICLE TOOLS

Tools

Vehicles with spare wheel

The jack and the tools are in a storage compartment in the load compartment above the spare wheel.

See *Spare wheel* on page 126.

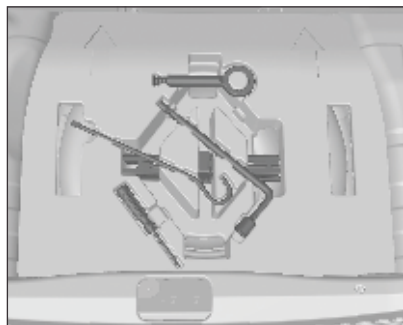
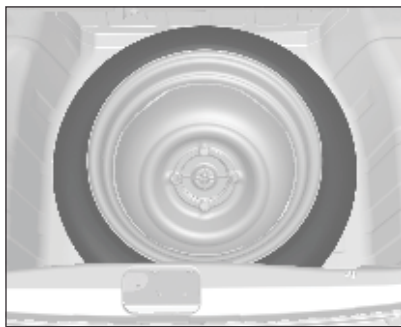

WHEELS AND TIRES

Tire And Wheel Condition

Drive over edges slowly and at right angles if possible. Driving over sharp edges can cause tire and wheel damage. Do not trap tires on the kerb when parking.

Regularly check the wheels for damage. Seek the assistance of a CHEVROLET retailer in the event of damage or unusual wear.

Winter Tires

Winter tires improve driving safety at temperatures below 7°C and should therefore be fitted on all wheels.

Tire Designations

E.g. **215/60 R 16 95 H**

215: Tire width, mm

60: Cross-section ratio (tire height to tire width), %

R: Belt type: Radial

RF: Type: RunFlat

16: Wheel diameter, inches

95: Load index e.g. 95 is equivalent to 690 kg

H : Speed code letter

Speed code letter:

Q : up to 160 km/h

S : up to 180 km/h

T : up to 190 km/h

H : up to 210 km/h

V : up to 240 km/h

W : up to 270 km/h

Tire Pressure

Check the pressure of cold tires at least every 14 days and before any long journey. Do not forget the spare wheel.

Unscrew the valve cap.

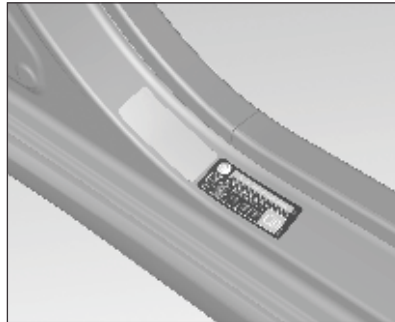

Tire pressure label is on the driver's door frame.

The tire pressure data refers to cold tires. It applies to summer and winter tires.

Always inflate the spare tire to the pressure specified on the tire pressure label.

Incorrect tire pressures will impair safety, vehicle handling, comfort and fuel economy and will increase tire wear.

Warning

If the pressure is too low, this can result in considerable tire warmup and internal damage, leading to tread separation and even to tire blow-out at high speeds.

Tread Depth

Check tread depth at regular intervals. Tires should be replaced for safety reasons at a tread depth of 2-3 mm (4 mm for winter tires).



The legally permissible minimum tread depth (1.6 mm) has been reached when the tread has worn down as far as one of the tread wear indicators (TWI). Their position is indicated by markings on the sidewall.

If there is more wear at the front than the rear, swap round front wheels and rear wheels. Ensure that the direction of rotation of the wheels is the same as before.

Tires age, even if they are not used. We recommend tire replacement every 6 years.

⚠ Warning

Use of unsuitable tires or wheels may lead to accidents and will invalidate the vehicle type approval.

⚠ Warning

Do not use different size and type of tires and wheels than those originally installed on the vehicle. It can affect safety and performance of the vehicle. It could lead to handling failure or rollover and serious injury. When replacing tires, be sure to install all four tires and wheels of the same size, type, tread, brand and load-carrying capacity. The use of any other tire size or type may seriously affect ride, handling, ground clearance, stopping distance, body clearance and speedometer reliability.

Tire Rotation

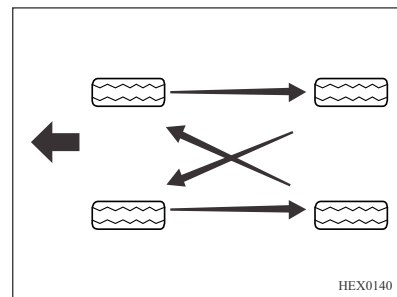

Front tires and rear tires have different working conditions, and therefore they wear out at different rates.

Normally, the front tires will wear faster than rear tires. To make your tires last longer and to avoid uneven tread wear:

1. Have the tires rotated according to the maintenance schedule in the Manual.
2. Maintain a proper tire pressure.
3. Inspect the tightness of wheel nuts.

Wheel Covers

Wheel covers and tires that are factory approved for the respective vehicle and comply with all of the relevant wheel and tire combination requirements must be used.

If the wheel covers and tires used are not factory approved, the tires must not have a rim protection ridge.

Wheel covers must not impair brake cooling.

Warning

Use of unsuitable tires or wheel covers could lead to sudden pressure loss and thereby accidents.

Tire Changing

Mixing tires could cause you to lose control while driving.

If you mix tires of different sizes, brands, or types (radial and bias-belted tires), the vehicle may not handle properly, and you could have a crash. Using tires of different sizes, brands, or types may also cause damage to your vehicle. Be sure to use the correct size, brand, and type of tires on all wheels.

Make the following preparations and observe the following information:

- Pull over your vehicle to a safe place away from traffic.
- Park the vehicle on a level, firm and non-skid surface. The front wheels must be in the straight-ahead position.
- Applying the parking brake and engage first gear or reverse gear.

- Turn off the engine and remove key.
- Turn on the hazard flashers.
- Use a wedge, block of wood, or rocks in front of and behind the tire that is diagonal from the tire you plan to change.
- Have all passengers get out of the vehicle.
- Remove the spare wheel. See *Spare wheel* on page 126.
- Never change more than one wheel at once.
- Use the jack only to change wheels in case of puncture, not for seasonal winter or summer tire change.
- If the ground on which the vehicle is standing is soft, a solid board (max. 1cm (0.4 inches) thick) should be placed under the jack.
- No people or animals may be in the vehicle when it is jacked-up.

- Never crawl under a jacked-up vehicle.
- Do not start the vehicle when it is raised on the jack.
- Clean wheel nuts and thread before mounting the wheel.



1. Disengage wheel covers with a screwdriver and remove.

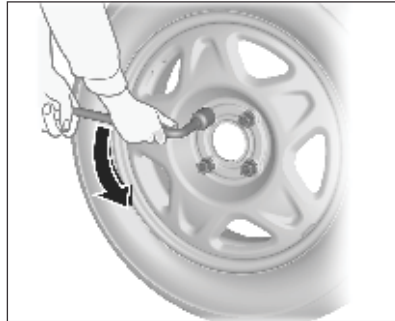

2. Pull out the wheel wrench and install ensuring that it locates securely and loosen each wheel nut by half a turn.

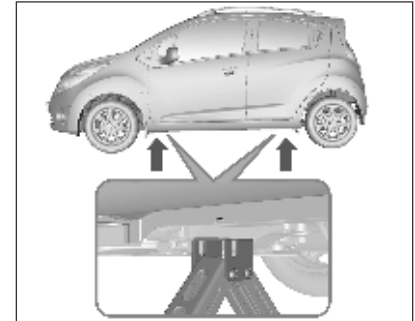

3. Rotate the jack handle to raise the lift head slightly and place the jack vertically at the position as shown.



4. Attach jack handle to the jack and attach wrench to the jack handle correctly.
Then raise the jack to join the lift head at the jacking position firmly.



5. Rotate the wrench checking the correct position of jack until wheel is clear of the ground.
6. Unscrew the wheel nuts.
7. Change the wheel.
8. Screw on the wheel nuts.
9. Lower vehicle.
10. Install the wheel wrench ensuring that it locates securely and tighten each nut in a crosswise sequence. Tightening torque is 120 N.m.

11. Align the valve hole in the wheel cover with the tire valve before installing.
Install wheel covers.
12. Stow the replaced wheel and the vehicle tools.
See *Tools* on page 120.
13. Check the tire pressure of the installed tire and also the wheel nut torque as soon as possible.

Have the defective tire renewed or repaired.

Spare Wheel

The spare wheel can be classified as a temporary spare wheel depending on the size compared to the other mounted wheels and country regulations.

The spare wheel has a steel rim.

Use of a spare wheel that is smaller than the other wheels or together with winter tires could affect driveability. Have the defective tire replaced as soon as possible.

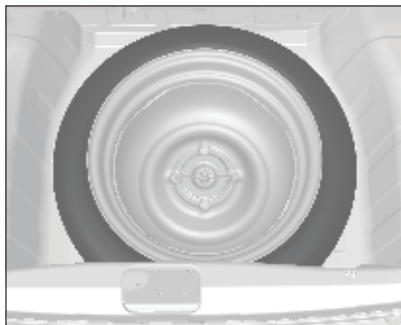

The spare wheel is located in the load compartment beneath the floor covering. It is secured in the recess with a wing nut.

The spare wheel well is not designed for all permitted tire sizes. If a wheel wider than the spare must be stowed in the spare wheel well after changing wheels, the floor cover can be placed on the projecting wheel.

Caution

This spare wheel/tire assembly is for temporary emergency use only.

Replace with regular wheel/tire assembly as soon as possible.

Do not use tire chains.

Do not install any tire on this wheel which is not identical to the original.

Do not install on other vehicles.

Directional Tires

Fit directional tires such that they roll in the direction of travel. The rolling direction is indicated by a symbol (e.g. an arrow) on the sidewall.

The following applies to tires fitted opposing the rolling direction:

- Driveability may be affected. Have the defective tire renewed or repaired as soon as possible.
- Drive particularly carefully on wet and snow-covered road surfaces.

JUMP STARTING

Do not start with quick charger.

A vehicle with a discharged battery can be started using jump leads and the battery of another vehicle.

⚠ Warning

Be extremely careful when starting with jump leads. Any deviation from the following instructions can lead to injuries or damage caused by battery explosion or damage to the electrical systems of both vehicles.

Avoid contact of the battery with eyes, skin, fabrics and painted surfaces. The fluid contains sulphuric acid which can cause injuries and damage in the event of direct contact.

- Never expose the battery to naked flames or sparks.
- A discharged battery can already freeze at temperatures of 0°C. Defrost the frozen battery before connecting jump leads.

- Wear eye protection and protective clothing when handling a battery.
- Use a booster battery with the same voltage (12 V). Its capacity (Ah) must not be much less than that of the discharged battery.
- Use jump leads with insulated terminals and a cross section of at least 16 mm².
- Do not disconnect the discharged battery from the vehicle.
- Switch off all unnecessary electrical consumers.
- Do not lean over the battery during jump starting.
- Do not allow the terminals of one lead to touch those of the other lead.
- The vehicles must not come into contact with each other during the jump starting process.
- Apply the parking brake, transmission in neutral.

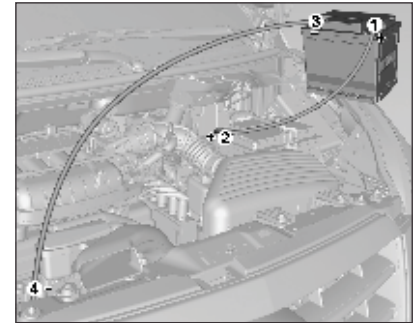

Lead connection order:

1. Connect the red lead to the positive terminal of the booster battery.
2. Connect the other end of the red lead to the positive terminal of the discharged battery.
3. Connect the black lead to the negative terminal of the booster battery.
4. Connect the other end of the black lead to a vehicle grounding point, such as the engine block or an engine mounting bolt.

Connect as far away from the discharged battery as possible, however at least 60 cm(24 inches).

Route the leads so that they cannot catch on rotating parts in the engine compartment.

To start the engine:

1. Start the engine of the vehicle providing the jump.
2. After 5 minutes, start the other engine. Start attempts should be made for no longer than 15 seconds at an interval of 1 minute.
3. Allow both engines to idle for approx. 3 minutes with the leads connected.
4. Switch on electrical consumers (e.g. headlamps, heated rear window) of the vehicle receiving the jump start.
5. Reverse above sequence exactly when removing leads.

TOWING

Towing The Vehicle

If you need to have your vehicle towed, contact your CHEVROLET retailer or professional towing company.

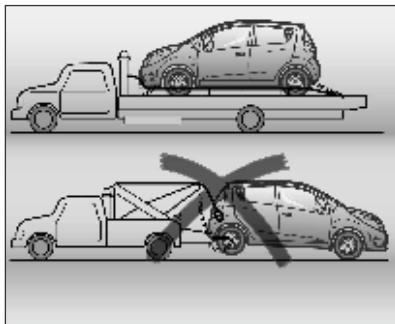

The best method is to have the vehicle transported using a recovery vehicle.

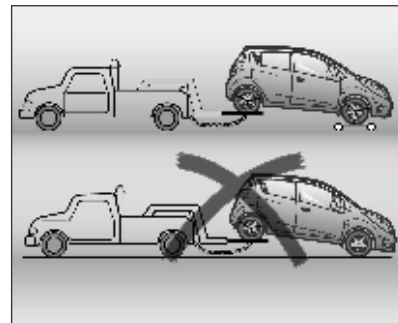
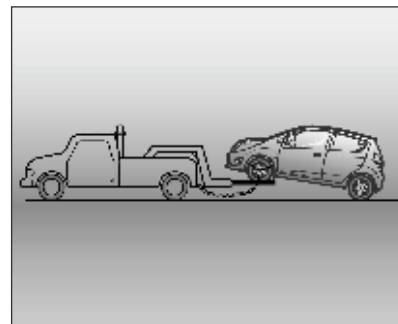

If towing by 2 wheels, lift the front driving wheels and tow with the front tires locked.

Please observe the following procedures when towing a vehicle:

- No passenger should remain in the vehicle being towed.
- Release the parking brake of the towed vehicle and place the transmission gear in neutral.
- Switch on the hazard warning lights.
- Keep the speed limits.

If it is not possible to have your vehicle towed by a recovery vehicle, proceed as follows.

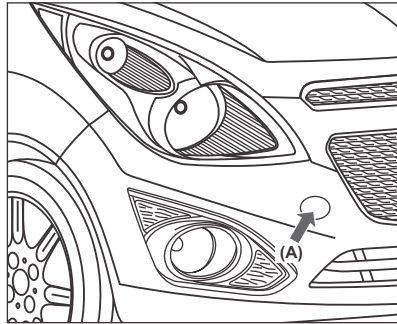

Disengage the cap by using coin or card at the arrow position (A) and remove the cap.

The towing eye is stowed with the vehicle tools.

See *Tools* on page 120.

Caution

Drive slowly. Do not drive jerkily.
Excessive tractive force can damage the vehicle.

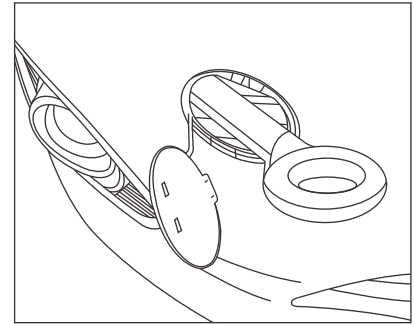

Screw in the towing eye as far as it will go until it stops in a horizontal position.

Attach a tow rope or better still a tow rod to the towing eye.

The towing eye must only be used for towing and not for recovering the vehicle.

Switch on ignition to release steering column lock and to permit operation of brake lights, horn and windshield wipers.

Transmission in neutral.

When the engine is not running, considerably more force is needed to brake and steer.

To prevent the entry of exhaust fumes from the towing vehicle, move the lever to the air recirculation mode and close the windows.

Seek the assistance of a CHEVROLET retailer.

Vehicles with manual transmission:

The vehicle must be towed facing forward, not faster than 88 km/h. In all other cases and when the transmission is defective, the front axle must be raised off the ground.

After towing, unscrew the towing eye.

Insert cap below and close cap.

The best method is to have the vehicle transported using a recovery vehicle.

Towing Another Vehicle

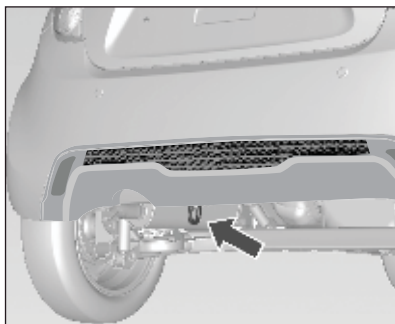

The rear towing eye is located under the rear bumper.

The towing eye must only be used for towing and not for recovering a vehicle.

Caution

Drive slowly. Do not drive jerkily.
Excessive tractive force can damage the vehicle.

APPEARANCE CARE

Exterior Care

Locks

The locks are lubricated at the factory using a high quality lock cylinder grease. Use de-icing agent only when absolutely necessary, as this has a degreasing effect and impairs lock function. After using de-icing agent, have the locks regreased by a CHEVROLET retailer.

Washing

The paintwork of your vehicle is exposed to environmental influences. Wash and wax your vehicle regularly. When using automatic vehicle washes, select a programme that includes waxing.

Bird droppings, dead insects, resin, pollen and the like should be cleaned off immediately, as they contain aggressive constituents which can cause paint damage.

If using a vehicle wash, comply with the vehicle wash manufacturer's instructions. The windshield wipers and rear window wiper must be switched off. Lock the

vehicle so that the fuel filler flap cannot be opened. Remove antenna and external accessories such as roof racks etc.

If you wash your vehicle by hand, make sure that the insides of the wheel housings are also thoroughly rinsed out.

Clean edges and folds on opened doors and the hood as well as the areas they cover.

Have the door hinges of all doors greased by a CHEVROLET retailer.

Do not clean the engine compartment with a steam-jet or high-pressure jet cleaner.

Thoroughly rinse and leather-off the vehicle. Rinse leather frequently. Use separate leathers for painted and glass surfaces: remnants of wax on the windows will impair vision.

Do not use hard objects to remove spots of tar. Use tar removal spray on painted surfaces.

Exterior lights

Headlight and other light covers are made of plastic. Do not use any

abrasive or caustic agents, do not use an ice scraper, and do not clean them dry.

When removing insect debris, grease dirt or tar from the lights or lenses, only use lukewarm water, a soft cloth and a car washing soap.

Cleaning with a dry cloth can damage the light covers. Do not clean with intensive car washing fluid. Avoid using hazardous cleaner with the lights switched on. This can cause the lens to crack due to chemical reaction.

Note

Follow the car-washing guide and use mild detergent. Otherwise micro lens cracks and welding area cracks could occur. Never use any of the below mentioned for cleaning:

- Acetone
- Benzene
- Toluene
- Xylene
- Thinner

Polishing and waxing

Wax the vehicle regularly (at the latest when water no longer beads). Otherwise, the paintwork will dry out.

Polishing is necessary only if the paint has become dull or if solid deposits have become attached to it.

Paintwork polish with silicone forms a protective film, making waxing unnecessary.

Plastic body parts must not be treated with wax or polishing agents.

Windows and windshield wiper blades

Use a soft lint-free cloth or chamois leather together with window cleaner and insect remover.

When cleaning the rear window, make sure the heating element inside is not damaged.

For mechanical removal of ice, use a sharp-edged ice scraper. Press the scraper firmly against the glass so that no dirt can get under it and scratch the glass.

Clean smearing wiper blades with a soft cloth and window cleaner.

Interior Care

Interior and upholstery

Only clean the vehicle interior, including the instrument panel fascia and panelling, with a dry cloth or interior cleaner.

The instrument panel should only be cleaned using a soft damp cloth.

Clean fabric upholstery with a vacuum cleaner and brush. Remove stains with an upholstery cleaner.

Clothing fabrics may not be colourfast. This could cause visible discolourations, especially on light-coloured upholstery. Removable stains and discolourations should be cleaned as soon as possible.

Clean seat belts with lukewarm water or interior cleaner.

Caution

Close Velcro fasteners as open Velcro fasteners on clothing could damage seat upholstery.

Plastic and rubber parts

Plastic and rubber parts can be cleaned with the same cleaner as used to clean the body. Use interior cleaner if necessary. Do not use any other agent. Avoid solvents and petrol in particular. Do not use highpressure jet cleaners.

SERVICE AND MAINTENANCE

General information..... 133
Scheduled maintenance 134
Recommended fluids and lubricants 137

GENERAL INFORMATION

Service Information

In order to ensure economical and safe vehicle operation and to maintain the value of your vehicle, it is of vital importance that all maintenance work is carried out at the proper intervals as specified.

Confirmations

Confirmation of service is recorded in the Service and Warranty booklet.

The date and mileage is completed with the stamp and signature of the servicing CHEVROLET retailer.

Make sure that the Service and Warranty booklet is completed correctly as continuous proof of service is essential if any warranty or goodwill claims are to be met, and is also a benefit when selling the vehicle.

134 Service and Maintenance

SCHEDULED MAINTENANCE

Service Schedules

Maintenance services and record retention are the owner's responsibility. You should retain evidence that proper maintenance has been performed on your vehicle in accordance with the scheduled maintenance services chart.

For vehicles with normal annual mileage.

MAINTENANCE ITEM	MAINTENANCE INTERVAL	Kilometers or time in months, whichever comes first													
		6 months/7500	1 Year/15000	1.5 Years/22500	2 Years/30000	2.5 Years/37500	3 Years/45000	3.5 Years/52500	4 Years/60000	4.5 Years/67500	5 Years/75000	5.5 Years/82500	6 Years/90000	6.5 Years/97500	7 Years/105000

ENGINE CONTROL SYSTEM

Drive Belt (Alternator, Power steering and A/C compressor)	I	I	I	I	I	I	I	I	I	I	I	I	I	I	I
Engine Oil and Engine Oil Filter (1) (3)	I	R	I	R	I	R	I	R	I	R	I	R	I	R	I
Cooling System and Hose Connections	I	I	I	I	I	I	I	I	I	I	I	I	I	I	I
Engine Coolant (3)	I	I	I	I	I	I	R	I	I	I	I	I	I	I	R
Fuel Filter	I	I	I	R	I	I	I	R	I	I	I	R	I	I	I
Fuel Line and Connections	I	I	I	I	I	I	I	I	I	I	I	I	I	I	I
Air Cleaner Element (2)	I	I	I	R	I	I	I	R	I	I	I	R	I	I	I
Spark Plugs	I	I	I	R	I	I	I	R	I	I	I	R	I	I	I
Spark Plug Wires	I	I	I	I	I	I	I	I	I	I	I	I	I	I	I
EVAP Canister, Vapor Lines & Solenoid Valve Filter			I			I			I			I			
PCV System			I			I			I			I			

Chart Symbols:

I- Inspect these items and their related parts. If necessary, correct, clean, replenish, adjust, rotate or replace.

R- Replace or change

- (1) If a vehicle is operated under severe conditions: short distance driving, extensive idling or driving in dusty conditions, change engine oil and the filter every 7,500 kms or 6 months, whichever comes first.
- (2) Inspect the air cleaner element every 7,500 kms or 6 months if vehicle is driven under dusty driving conditions. If necessary correct, clean or replace.
- (3) Refer to "FLUID CHART" on page 142.

For vehicles with normal annual mileage.

MAINTENANCE ITEM	MAINTENANCE INTERVAL	Kilometers or time in months, whichever comes first													
		6 months/7500	1 Year/15000	1.5 Years/22500	2 Years/30000	2.5 Years/37500	3 Years/45000	3.5 Years/52500	4 Years/60000	4.5 Years/67500	5 Years/75000	5.5 Years/82500	6 Years/90000	6.5 Years/97500	7 Years/105000
CHASSIS AND BODY															
Exhaust Pipe & Mountings		I	I	I	I	I	I	I	I	I	I	I	I	I	I
Brake Fluid (3) (4)		I	I	I	R	I	I	I	R	I	I	I	R	I	I
Front Brake Discs & Pads (5)		I	I	I	I	I	I	I	I	I	I	I	I	I	I
Rear Brake Drums & Linings (5)		I	I	I	I	I	I	I	I	I	I	I	I	I	I
Parking Brake		I	I	I	I	I	I	I	I	I	I	I	I	I	I
Brake Line & Connections (Including Booster)		I	I	I	I	I	I	I	I	I	I	I	I	I	I
Manual Transaxle Fluid (3)		I	I	I	I	I	I	I	I	I	I	I	I	I	I
Chassis & Underbody Bolts & Nuts Tight / Secure		I	I	I	I	I	I	I	I	I	I	I	I	I	I

Chart Symbols:

I- Inspect these items and their related parts. If necessary, correct, clean, replenish, adjust, rotate or replace.

R- Replace or change

(3) Refer to “FLUID CHART” on page 142.

(4) Change the brake fluid every 20,000 kms or 2 years (whichever is earlier) if the vehicle is mainly driven under severe conditions:

- Driving in hilly or mountainous terrain, or
- Towing a trailer frequently.

(5) More frequent maintenance is required if under severe condition: frequent low-speed operation in stop-and go traffic or driving in dusty conditions.

136 Service and Maintenance

For vehicles with normal annual mileage.

MAINTENANCE ITEM	MAINTENANCE INTERVAL		Kilometers or time in months, whichever comes first													
	6 months/7500	1 Year/15000	1.5 Years/22500	2 Years/30000	2.5 Years/37500	3 Years/45000	3.5 Years/52500	4 Years/60000	4.5 Years/67500	5 Years/75000	5.5 Years/82500	6 Years/90000	6.5 Years/97500	7 Years/105000		
CHASSIS AND BODY																
Tire Condition, Inflation Pressure & Rotation	I	I	I	I	I	I	I	I	I	I	I	I	I	I	I	
Wheel Alignment (6)	As and when required or as suggested by CHEVROLET retailer															
Wheel Balancing (6)	As and when required or as suggested by CHEVROLET retailer															
Steering Wheel & Linkage	I	I	I	I	I	I	I	I	I	I	I	I	I	I	I	
Power Steering Fluid & Lines	I	I	I	I	I	I	I	I	I	I	I	I	I	I	I	
Drive Shaft Boots	I	I	I	I	I	I	I	I	I	I	I	I	I	I	I	
Safety Belts, Buckles & Anchorages	I	I	I	I	I	I	I	I	I	I	I	I	I	I	I	
Lubricate Locks, Hinges & Hood Latch	L	L	L	L	L	L	L	L	L	L	L	L	L	L	L	
Pollen Filter	I	R	I	R	I	R	I	R	I	R	I	R	I	R	I	

Chart Symbols:

I- Inspect these items and their related parts. If necessary, correct, clean, replenish, adjust, rotate or replace.

R- Replace or change

(6) If necessary, rotate and balance wheels.

Additional Servicing

Extreme operating conditions

Extreme operating conditions are given when at least one of the following occurs frequently:

- Repeated short-distance driving less than 5 miles (10 kms).
- Extensive idling and/or slow-speed driving in stop-and-go traffic.
- Driving on dusty roads.
- Driving on hilly or mountainous terrain.

Caution

Chevrolet recommends to consult authorized CHEVROLET retailer for instructions and vehicle health check-up before setting out a long journey.

- Towing a trailer.
- Driving in heavy city traffic where the outside temperatures regularly reach 90° F (32°C) or higher.
- Driving as a taxi, police or delivery vehicle.

- Frequent driving when outside temperature remains below freezing.

Police vehicles, taxis and driving school vehicles are also classified as operating under extreme conditions.

Under extreme operating conditions, it may be necessary to have certain scheduled service work done more frequently than the scheduled intervals.

Seek technical advice on the servicing requirements dependent on the specific operating conditions.

RECOMMENDED FLUIDS AND LUBRICANTS

Only use products that have been tested and approved. Damage resulting from the use of non approved materials will not be covered by the warranty.

Warning

Operating materials are hazardous and could be poisonous. Handle with care. Pay attention to information given on the containers.

Engine oil

Engine oil is identified by its quality and also its viscosity. Quality is more important than viscosity when selecting which engine oil to use.

Selecting the right engine oil

Selecting the right engine oil depends on both the proper oil specification and viscosity grade.

Engine oil :

5W-30API SM GF4

Engine oil additives

The use of engine oil additives could cause damage and invalidate the warranty.

Engine oil system flushes are not recommended and could cause engine damage not covered by the vehicle warranty.

Coolant and antifreeze

Use only organic acid type-long life coolant (LLC) antifreeze.

In countries with moderate climate the coolant provides freeze protection down to approx. -25°C.

This concentration should be maintained all year-round.

Coolant additives intended to give additional corrosion protection or seal against minor leaks can cause functional problems. Liability for consequences resulting from the use of coolant additives will be rejected.

Coolant : Ethylene Glycol (Organic acid type long life coolant).

Brake fluid

Only use our authorized brake fluid for this vehicle (DOT 4).

Over time, brake fluid absorbs moisture which will reduce braking effectiveness. The brake fluid should therefore be replaced at the specified interval.

Brake fluid should be stored in a sealed container to avoid water absorption.

Ensure brake fluid does not become contaminated.

Power steering fluid

Only use Dexron VI fluid.

Manual transmission fluid

Only use Shell XGP SAE75W85 fluid.

TECHNICAL DATA

Vehicle identification 139
Vehicle data 140
Capacities and specifications 142

VEHICLE IDENTIFICATION

Vehicle Identification Number

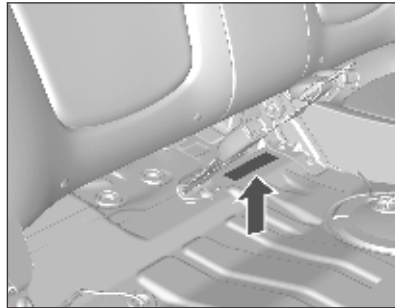

The vehicle identification number is located under the rear seat cushion.

Identification Plate

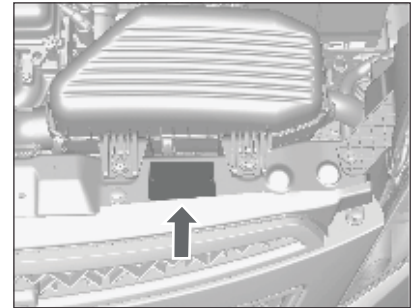

The identification plate is located in the engine compartment.

VEHICLE DATA

Engine Data

Engine identifier code	B12D1
Type	4-Cylinder/in line, Positive ignition
Bore x stroke, mm	69.5 x 79
Number of cylinders	4
Piston displacement, cc	1199
Engine Power [kW] at rpm	59.2 kW @ 6200 rpm
Torque [Nm] at rpm	108 Nm @ 4400 rpm
Octane rating RON	
Recommended	RON 91
Possible	Over RON 91

Brakes

Service brake	Hydraulic, vacuum assisted, diagonal circuit with auto slack adjuster
Auto slack adjuster fitted	Rear brake
ABS fitted	Optional
Front brakes	Disc
Rear brakes	Drum

Gear Box

Type / Model	Mechanical, Tunnel mounted gear shift lever, Manual transmission
No. of gears	5 Forward 1 Reverse
Gear ratios	
1st	3.539
2nd	1.952
3rd	1.323
4th	0.974
5th	0.781
Reverse	3.385
Drive axle	Front
Front axle ratio	4.190

Suspension

Type and description	Front: McPherson strut type suspension Rear : Compound crank type
Spring	Front : Side load compensation spring Rear : Linear spring
Anti-roll bar	Front : Solid bar type Rear : N/A
Shock absorbers	Front : Twin tube strut type (Gas) Rear : Twin tube shock absorbers type (Gas)

Chassis

Type	Monocoque
------	-----------

Steering

Type and description	Type: Rack & Pinion steering system Description: Hydraulic power assisted
----------------------	--

Vehicle Dimensions

Overall length [mm]	3640
Overall width [mm]	1595
Overall height [mm]	1520
Wheel base [mm]	2375
Front wheel track [mm]	1408
Rear wheel track [mm]	1403
Turning circle diameter [mm]	9690
Minimum ground clearance [mm]	165

Vehicle Weight

Kerb weight [kg]	965
Gross vehicle weight [kg]	1340

Wheels and Tires

Wheel rim size	14 x 4.5J (alloy)
	14 x 4.5J (steel)
Tire type	Radial, tubeless

CAPACITIES AND SPECIFICATIONS

Fluid Chart

Item	Classification	Capacity
Engine oil (Including oil filter)	5W-30 API SM GF4	3.75L
Transmission oil	XGP SAE 75W85	2.1L
Engine coolant	Ethylene Glycol (Organic acid type long life coolant)	4.74L
Brake fluid	DOT 4	0.5L
Power Steering fluid	Dexron VI	1.1L

Fuel Tank

Petrol, nominal capacity	35L
--------------------------	-----

Tire Pressures

Tire and Seating Information			
			
		2152U	
OCCUPANTS	TOTAL 5	FRONT 2	REAR 3
TIRE	SIZE	COLD TIRE PRESSURE	
FRONT	P155/70R14	220 kPa, 32 psi, 2.2 bar	
REAR	P155/70R14	220 kPa, 32 psi, 2.2 bar	
			96682152

Bulb Specifications

	Bulb	Wattage	Qty	Remarks
Front	Head lamp (High /Low)	H4 60/55W	2	Halogen
	Parking lamp	5W	2	
	Turn signal lamp	21W	2	Amber
	Fog lamp*	35W	2	Halogen
	Side turn signal lamp	5W	2	
Rear	Turn signal lamp	21W	2	Amber
	Brake/Tail lamp	21/5W	2	
	Reversing lamp	21W	2	
	CHMSL (Bulb type)	5W	5	
	CHMSL (LED type)*	LED module	-	
	Number plate lamp	5W	2	
Interior	Dome lamp	10W	1	

SERVICE AND WARRANTY

Standard limited warranty coverage	144
Predelivery inspection and vehicle delivery	153
Owner's statement of acceptance	155
Chevrolet service	157
Maintenance record sheet	163
Battery	165
Separate corrosion protection service	166
Body inspection record	167
Emission warranty	169
Annexure-I	173
Annexure-II	174

STANDARD LIMITED WARRANTY COVERAGE

1. SCOPE

General Motors India Private Limited, a private limited company incorporated under the companies Act 1956 and having its Registered office at Chandrapura Industrial Estate, Halol, District Panchmahals, Gujarat - 389351 and Works at A-16, MIDC Talegaon Industrial Area (Phase-II), Near Floriculture Park, Talegaon Navlakh Umbhre Village Road, Tehsil-Maval, Pune - 410507, Maharashtra ("General Motors India") warrants that your new Chevrolet Beat ("vehicle") is free from defect in material or workmanship, subject to your compliance with the following terms and conditions mentioned hereunder and other vehicle maintenance norms as mentioned elsewhere in this service booklet.

Only an authorized CHEVROLET retailer as mentioned in this booklet will make the necessary repairs, using new, re-conditioned or re-manufactured parts with a view to correcting any defect covered by this warranty.

2. WHAT IS COVERED

Time and distance limits for New Vehicle Warranty coverage.

Warranty Type	Warranty Limits	Other Warranties
A : General	Three (3) years or 1,00,000 kms (whichever is earlier) from the date of delivery by a CHEVROLET retailer or the date of first registration of the motor vehicle, whichever occurs first.	These parts are covered by other warranties : 1. Battery (one (1) year) (covered by the battery manufacturer**) 2. Tires (one (1) year) (covered by the tire manufacturer**) 3. Audio/Radio/Acc. (one (1) year) (covered by the Audio/Radio/Acc. manufacturer**) See clause 5.
B : Rust Through*	Three (3) years from the date of delivery of the motor vehicle or from the date of first registration of the motor vehicle, whichever occurs first.	The warranty covers exterior body metal except : 1. Items not covered by warranty listed in Clause 3 2. Exhaust pipe and fuel system rust

* A hole through a body panel caused by rust / corrosion from inside to outside.

** Service / warranty shall be provided by the concerned equipment manufacturer.

- The obligation under this New Vehicle Warranty is limited to the repair of the new motor vehicle at no charge by the CHEVROLET authorized retailer. For parts replaced during such repair the same warranty applies until the end of the New Vehicle Warranty period as stipulated herein. All warranty claims expire at the end of the warranty period as specified under Clause 2. The Owner is responsible for any repair or replacement which are not covered by this warranty.
- Liability of **General Motors India Pvt. Ltd.** under this New Vehicle Warranty is limited to the value of the service, repairs/ replacement of parts found to be defective within the warranty period. Beyond servicing and/or repairing defective parts in the vehicle, **General Motors India Pvt. Ltd.** does not undertake to replace the vehicle / or reimburse the purchaser by payment of any money in respect of the vehicle purchased by them.
- Under the terms of New Vehicle Warranty, installation, free service will be provided only within the municipal limits of the cities/towns where **General Motors India Pvt. Ltd.** has its service network, *as elaborated elsewhere in this Owner's Manual*. This list of authorized retailers is subject to change/modification without prior notice. Service outside the municipal limits specified above will be provided after charging the actual to and fro traveling and incidental expenses, as prevailing from time to time.
- Necessary care and caution is taken in manufacturing of the vehicle, however, **General Motors India Pvt. Ltd.** shall not be liable for any loss or damage caused to any article, property, death or disability caused to any human life arising out of fire, electric fault, short circuit, accidental handling or negligent use of the vehicle. The maximum liability in monetary terms shall be restricted to the value of the defective parts and / or value of services rendered only. Furthermore, the New Vehicle Warranty, in no case, shall extend to the payment of any monetary consideration whatsoever, of the replacement or return of the vehicle as a whole.
- The decision of **General Motors India Pvt. Ltd.** will be final and binding on all matters arising out of this New Vehicle Warranty.
- The owner should preserve the original Invoice for necessary verification and produce the same, as and when required.
- The optimum performance of the vehicle is under standard test conditions.

This New Vehicle Warranty is issued at Talegaon, District Pune, Maharashtra and competent courts shall have exclusive jurisdiction over matters by or following from time to time.

3. WARRANTY LIMITATIONS

The warranty will cease to exist in following conditions:

- a. Failure to have the required periodic inspection and required service performed as per the Periodic Maintenance Schedule.
- b. Improper or wrong maintenance and in deviation with guidelines mentioned in this service booklet.
- c. Any modification, alterations made to the vehicle such as including but not restricted to adding lights, changing engine specifications to increase horsepower, or using wide tires, and or any other modification in the vehicle that may likely to have an effect on the performance of the vehicle. (e.g. defects caused by the installation of non homologated wheels and tires are not covered by the warranty.)
- d. Failure to use genuine parts / fluids (oil, coolant, brake fluid) and/or other accessories / consumables recommended or approved by General Motors India Pvt. Ltd.
- e. Use of the vehicle for purposes or in a manner other than the one mentioned in the Owner's Manual. Exceeding specified capacities such as loading weight, passenger, speed, use as a commercial vehicle and rpm limitations.
- f. Damage caused by driving the vehicle under severe conditions such as un-pliable or water-logged roads, in races or rallies.
- g. Damage caused by natural disasters including but not restricted to earthquakes, storms, floods, fire and accidents. The owners are recommended to keep their vehicle insurance valid at all times.
- h. Damage caused by smoke, chemicals, bird-droppings, salt, stone chipping, scratches, iron dust or any other extraneous circumstances like external mechanical or chemical influences (regarding paint or body damage, specially stone throw, air-borne rust, industrial fall out), damage to catalytic converter due to use of wrong/bad quality fuel acting on the vehicle.
- i. Damage caused by normal wear (for instance brake-pad, etc.) or exposure to the elements such as discoloring or deformation of any interior, plastic, chrome or painted part or surface.
- j. Sensory complaint by the owner against symptoms such as noise, vibration or oil stains which do not effect performance.

- k. Damage which should have been detected during normal usage but became serious when left unattended to and/or the owner of the vehicle having failed to claim and having rectified a defect which was already apparent during vehicle delivery, immediately after delivery or a defect which becomes apparent at a later date immediately after it became apparent.
- l. Failure of the owner to adhere to the requirements outlined in Clause 4.
- m. Fuel system damage caused by water or other foreign matter in the fuel system.
- n. Damage caused by the installation of non genuine accessories or equipment after the vehicle has been purchased from the CHEVROLET retailer such as radio, car telephone, CD radio set, or cargo carrier and / or other activities of a similar nature.
- o. Damage caused by running vehicle on adulterated fuel/lubricants or fuel/lubricants other than those specified by General Motors India Pvt. Ltd.

WHAT IS NOT COVERED

- Adjustments, cleaning, inspection, or required periodic maintenance.
- Parts designated as requiring periodic replacement.
- Warranty repair not performed by a CHEVROLET retailer.
- Charges or fees for telephone, tow, transportation charges of the vehicle to the nearest CHEVROLET retailer, rental car, and so forth; compensation for inconvenience or commercial losses; all other consequential costs relating to the owner being unable to use the vehicle.
- Any accident, damage, loss or destruction due to negligent, careless use of vehicle.
- Damage to the engine while driving in water logged conditions or entry of water in to the engine.
- Consumptive parts and oil/grease and other fluids. (See the following tables of consumptive parts and oil/grease and other fluids.)

Consumptive Parts	Oil/Grease and other fluids
Spark plug (Gasoline)	Engine oil
Drive belts	Transmission oil
Air cleaner element	Power steering fluid
Fuel filter	Brake fluid
Oil filter	Coolant
Clutch disc, clutch parts	Grease
Brush holders	Washer fluid
Brake shoe and pads	Battery fluid
Brake discs	Gasoline
Brake drums	Air conditioner refrigerant
Wiper blades	Other lubricants, etc.
Light bulbs	
Motor brushes	
Fuses, etc.	

No warranty repair shall be made if it is found that the vehicle Identification number like chassis / engine number, odometer or the warranty & service booklet, have been tampered with. This list is neither exclusive nor exhaustive and the decision of General Motors India Pvt. Ltd. shall be final and binding.

4. WHAT THE OWNER MUST DO

In order to keep this warranty valid you must:

- a. Use your vehicle as instructed in the Owner's Manual.
- b. Have your vehicle inspected according to this schedule.

The cost of the service is borne by the owner. If the services are not performed within the specified time limits, the general and the rust through warranty as referred to under Clause 2 above, shall be rendered null and void and shall not be reinstated by a subsequent service.

- c. Keep the warranty & service booklet (Owner's Manual) and all receipts in a safe place to present to the CHEVROLET retailer at regular maintenance visits and when repair work is required.

5. PARTS COVERED BY OTHER WARRANTY CONDITION

- a. Battery : The coverage period is 1 year from the date of new vehicle registration regardless of the distance traveled.
- b. Tires : This warranty is covered by the tire manufacturer. The coverage period is one year. Please check with your CHEVROLET retailer for details.
- c. Audio/Radio/Acc. : This warranty is covered by the audio/radio/Acc. manufacturer. The coverage period is one year. Please check with your CHEVROLET retailer for details.

6. MAKING THE WARRANTY EFFECTIVE

The warranty goes into effect after CHEVROLET authorized retailer fills in the appropriate information about your vehicle and places the retailer's official seal and signature in the warranty & service booklet (Owner's Manual).

7. REQUIREMENTS FOR WARRANTY WORK

To have warranty work carried out, present the warranty & service booklet to the authorized CHEVROLET retailer as mentioned in this booklet. If the warranty & service booklet is lost or incomplete, work to be carried out with respect to the standard warranty shall be refused.

8. CHANGE OF OWNERSHIP

If the vehicle is sold during the warranty period, please deliver the warranty & service booklet to the new owner.

The new owner will need to complete the change of address or subsequent ownership notification card located elsewhere in this booklet in order for the coverage to be transferred.

9. EXPENSES ASSOCIATED WITH WARRANTY WORK

The expenses of repair work and parts of your CHEVROLET vehicle will be covered by CHEVROLET standard limited warranty in accordance with the WARRANTY & SERVICE BOOKLET (OWNER'S MANUAL). Other expenses that are not covered by the CHEVROLET Standard Limited Warranty must be covered by the owner.

10. General Motors India Private Limited is launching the CHEVROLET Beat in different cities in a phased manner. The CHEVROLET retailer responsible for delivering your Beat is qualified to provide all Beat related services within the city where he is located. As other CHEVROLET retailers become operational to handle the Beat, they will also be able to provide similar Beat related services. **IN ORDER FOR THE WARRANTY ON YOUR VEHICLE TO APPLY, IT IS IMPERATIVE THAT YOUR BEAT BE SERVICED, HANDLED AND ATTENDED TO ONLY BY CHEVROLET RETAILER AS SET FORTH IN THIS BOOKLET.**

11. The following requisite document should be presented to the CHEVROLET retailer at the time of making a claim under New Vehicle Warranty:

- Original invoice issued by CHEVROLET retailer.
- Warranty and service booklet / maintenance record.
- Any other document deemed to be necessary by CHEVROLET retailer and/or General Motors India Pvt. Ltd.

PREDELIVERY INSPECTION AND VEHICLE DELIVERY

Before delivering the vehicle we carried out a thorough predelivery inspection in order to ensure that your Chevrolet vehicle is in a fault-free condition. Accompanying this appropriately filled out service booklet (Owner's Manual) are the tool kit and your vehicle documents.

You have been informed of the service intervals and necessary service checks, including under extreme operating conditions and in particular with regard to oil changing of petrol engines.

City, date :

CHEVROLET Retailer's / ASO's Stamp and Signature

**OWNER'S
STATEMENT OF ACCEPTANCE**

I hereby certify that the car has been delivered in an orderly and proper operating condition, including **Keys, Service booklet (Owner's Manual) and tool kit. I have read and understood the terms and conditions pertaining to the New Vehicle Warranty and agree to abide by the same.**

I have been informed of the service intervals and necessary service checks, including under extreme operating conditions.

Date of delivery :

City, date :

Name and signature of customer :

This sheet must be detached prior to vehicle delivery and placed with the vehicle file **after it has been signed** by the customer.



Dear Customer,

We are confident that you and your family would be enjoying the safe and comfortable drive of the Chevrolet Beat.

We would like to undertake a thorough check-up of the vehicle at 1000 kms or 30 days, whichever occurs earlier. This will also allow us to re-emphasize the salient features of the Beat to you.

In the unlikely event of an emergency assistance, please call your nearest CHEVROLET retailer as mentioned in this booklet or please feel free to call our 24 hr. helpline at 1800 3000 8080.

1000 kms/30 days reassurance check-up (whichever is earlier)

VIN no. _____

PDI no. _____

Date of service _____

Date of delivery _____

Retailer code _____

Customer's name _____

Customer's tel. no. _____

I confirm that the vehicle has been inspected and delivered to my satisfaction.

Retailer's Signature

Customer's Signature

1000 kms Reassurance check-up	
<p>General Status review Check closing efforts of doors, keyless entry system & other functions</p> <p>Under hood Visually check routing, leaks & damage</p> <ul style="list-style-type: none"> — Check fluid levels — Engine oil level — Brake oil level — Coolant level — Power steering oil — M/T oil <p>Windshield washer level & add washer fluid</p> <p>Underbody, wheels Visually check routing, leaks & damage</p> <p>Check tire pressure</p> <p>Electrical Checks Malfunction indicator lamp Charging lamp Oil pressure lamp</p>	<p>Parking brake lamp/indicator High beam/Turn signal Hazard indicator & all other telltale lamp Cigarette lighter/rear defogger Check lighting system Horn/Radio/Outside Mirrors High/Low beam/Hazard signal Turn signal/Flash to pass signal Front/Rear fog lamps/Tail lamps Stop lamp/Reversing lamp/Trunk lamp</p> <p>Dynamic Evaluation Steering function/noise/abnormal drag Clutch & gear shifting function/noise Accelerating & braking function/noise Check tires Any other abnormal noise</p>



CHEVROLET Inspection

2nd Service Check 1 year / 15000 kms whichever occurs earlier

VIN _____

Regn. No. _____

Delivery date _____

Date of service _____

Kms _____

I confirm that the job has been attended to my satisfaction.

Customer's Signature

Labour free & Parts are chargeable
(Retain with job card)

CHEVROLET Inspection

1st Service Check 6 months / 7500 kms whichever occurs earlier

VIN _____

Regn. No. _____

Delivery date _____

Date of service _____

Kms _____

I confirm that the job has been attended to my satisfaction.

Customer's Signature

Labour free & Parts are chargeable
(Retain with job card)

160 Service and Warranty

Delivering Retailer's stamp & date

I hereby certify that the work has been carried out as per the schedule.

Servicing Retailer's / ASO stamp & date

Delivering Retailer's stamp & date

I hereby certify that the work has been carried out as per the schedule.

Servicing Retailer's / ASO stamp & date

CHEVROLET Inspection

4th Service Check 2 years / 30000 kms whichever occurs earlier

VIN _____

Regn. No. _____

Delivery date _____

Date of service _____

Kms _____

I confirm that the job has been attended to my satisfaction.

Customer's Signature

Labour & Parts are chargeable
(Retain with job card)

CHEVROLET Inspection

3rd Service Check 1.5 years / 22500 kms whichever occurs earlier

VIN _____

Regn. No. _____

Delivery date _____

Date of service _____

Kms _____

I confirm that the job has been attended to my satisfaction.

Customer's Signature

Labour & Parts are chargeable
(Retain with job card)

162 Service and Warranty

Delivering Retailer's stamp & date

I hereby certify that the work has been carried out as per the schedule.

Servicing Retailer's / ASO stamp & date

Delivering Retailer's stamp & date

I hereby certify that the work has been carried out as per the schedule.

Servicing Retailer's / ASO stamp & date

BATTERY

Battery type : _____

Battery make : _____

Battery batch code/ Sl. No. : _____

Important Instructions

- The battery must be fitted firmly in the cradle.
- Connecting cables and connectors must be fastened securely on to the battery.
- Connections must be made in the right polarity.
- Terminals must be kept coated with petroleum jelly/vaseline. DO NOT USE GREASE.
- Battery top & vent plugs must always be kept clean & dry .
- Electrolyte level must always be maintained in line with the bottom of the vent hole. In case of any drop in electrolyte level, add pure distilled water. NEVER ADD ACID.
- Battery is warranted for a period of one year only.
- Liability under this warranty is limited to defects arising out of faulty material or workmanship developing under proper use and NOT when the battery is merely discharged.

- Defects arising out of faulty vehicle electrical systems, negligent maintenance, incorrect charging or improper filling of the battery by unauthorized dealers/auto electricians are not covered by warranty.
- Consequent liabilities are not covered by this warranty policy.
- Get Battery checked every 3 months.

CHEVROLET retailer's
Stamp

**SEPARATE
CORROSION PROTECTION
SERVICE**

Body/ Underbody Corrosion Protection Service

General Motors India Pvt. Ltd. provides a three (3) years or 1,00,000 kms (whichever is earlier) warranty vehicle that no rust-through of the body/underbody will occur, provided that the directives from General Motors India Pvt. Ltd. concerning the treatment, maintenance, and care of the vehicle (Owner's Manual) and especially the inspection and checks prescribed in the service booklet have been carried out.

Furthermore, the body paintwork and the corrosion protection must be visually inspected for damage as part of the regular annual inspection or 15,000 kms service. The customer is informed of any damage detected and measures to rectify this damage. Any damage discovered is also indicated in the following corrosion protection diagram.

Confirmation of the inspection is indicated by a stamp and dated signature, accompanied by indication of the vehicle mileage on the following verification documents.

Make use of this possibility in order to avoid problems during warranty claims regarding rust- through of the body / underbody.

The rust through warranty is not applicable if areas damaged by any reason remain unattended and become the cause of corrosion.

All repairs when required should be carried out promptly and by the CHEVROLET retailer.

BODY INSPECTION RECORD

Vehicle identification number _____

Registration number _____

Name / address of owner _____

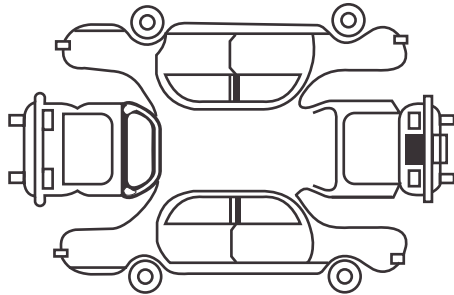

Use the following symbols to indicate damage.

- Chipping × Dent / Bumpy
- ▲ Scratch ■ Other damage
- ↑ Antirust re-treatment necessary

In order to maintain the General Motors India Pvt. Ltd. rust-through warranty, the vehicle must be subjected to an inspection by CHEVROLET retailer once a year. Any resulting work is subject to a charge.

Check-up 1st year after initial registration.

Check-up date _____

Odometer reading _____

- Damage found
- | | | |
|-----------------------|------------------------------|-----------------------------|
| 1. Outer body | Yes <input type="checkbox"/> | No <input type="checkbox"/> |
| 2. Under body | Yes <input type="checkbox"/> | No <input type="checkbox"/> |
| 3. Engine compartment | Yes <input type="checkbox"/> | No <input type="checkbox"/> |

Retailer stamp / signature _____

Damage repaired Yes No

Remarks : _____

BODY INSPECTION RECORD

Vehicle identification number _____

Registration number _____

Name / address of owner _____

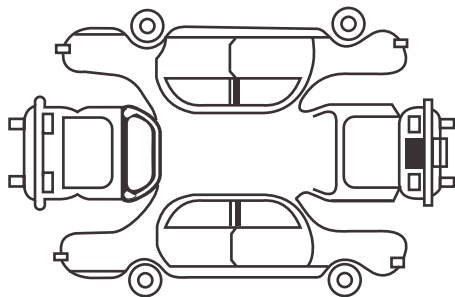

Use the following symbols to indicate damage.

- Chipping × Dent / Bumpy
- ▲ Scratch ■ Other damage
- ↑ Antirust re-treatment necessary

In order to maintain the General Motors India Pvt. Ltd. rust-through warranty, the vehicle must be subjected to an inspection by CHEVROLET retailer once a year. Any resulting work is subject to a charge.

Check-up 2nd year after initial registration.

Check-up date _____

Odometer reading _____

- Damage found
- | | | | | |
|-----------------------|-----|--------------------------|----|--------------------------|
| 1. Outer body | Yes | <input type="checkbox"/> | No | <input type="checkbox"/> |
| 2. Under body | Yes | <input type="checkbox"/> | No | <input type="checkbox"/> |
| 3. Engine compartment | Yes | <input type="checkbox"/> | No | <input type="checkbox"/> |

Retailer stamp / signature _____

Damage repaired Yes No

Remarks : _____

EMISSION WARRANTY

(Applicable in NCR Delhi, Chennai, Kolkata and Mumbai)

Subject to other terms of the warranty policy and the conditions and obligations laid down hereunder, General Motors India Pvt. Ltd., certifies that the components liable to affect the emission of the gaseous pollutants in the vehicle in the normal use despite the use to which it may be subjected, comply with the provisions of Rule 115 (2) of the central Motor Vehicle Rules, 1989, and further warrants that if on examination by a service center duly authorized by the General Motors India Pvt. Ltd., the vehicle is discovered to be failing to meet the emission standard as specified in the said rule, our authorized service center shall take such corrective measures as may be necessary and shall at its sole discretion either repair or replace free of charge such components of emission control system as are specified in Annexure II hereof.

The definitions of various terms used in Emission warranty proposal are given in Annexure –I. These definitions shall

be in line with the definition of the existing product Warranty definition.

Conditions :

1. This warranty will be in addition to and will run concurrently and parallel to the product warranty and will apply only in respect to components as mentioned in Annexure-II.
2. The period of the vehicle's warranty shall commence from the date of the vehicle sale.
 - 2.1 Warranty period - **1,00,000 kms or 3 years** whichever occurs earlier, from date of the vehicle sale.
3. The warranty claim will be accepted only after examination carried out by CHEVROLET retailers leading to a firm conclusion that none of the original settings /specifications have been tampered with and that the components (s) as mentioned in Annexure –II has/have a manufacturing defect, and /or, that the vehicle is unable to meet the In-use emission standards.
4. The methods of examination to determine the warrantable condition of the components will be at sole discretion of General Motors India Pvt. Ltd. and or its retailers and results of such examination will be final and binding. If, on examination, the warrantable condition is not established, General Motors India Pvt. Ltd. will have the right to charge full, or part, of the cost of such examination and resulting repairs /rectification
5. In case of acceptance of the warranty under Emission Warranty, General Motors India Pvt. Ltd. will replace, at retailers, free of charge, the components which are covered as mentioned in Annexure-II, but the consumables as mentioned in OM shall be charged as per actual applicable rates.
6. In case of a vehicle in which the components covered under Emission Warranty or the associated parts, are not independently replaceable, on account of their being integral

parts of a complete assembly, will have the sole discretion to replace either the entire assembly or by using some of the parts of the system through suitable repairs or modifications.

7. Any consequential repairs or replacement of parts which may be found necessary to establish compliance to In-use emission standards, in addition to the replacement of the components covered under Emission Warranty, will not be made free of cost unless such parts are also found to be in a warrantable condition within the scope and limit of the product Warranty (**Chevrolet Beat -3 years/1,00,000 kms, whichever is earlier**). The consumables and labour shall be charged per actual during such repairs or replacement of parts.
8. All the parts removed for replacement under warranty will be the property of General Motors India Pvt. Ltd.

9. General Motors India Pvt. Ltd. will not be responsible for the cost of transportation of the vehicle to the nearest retailer or any loss due to non-availability of the vehicle during the period of a warranty claim and examination by CHEVROLET retailers.
10. General Motors India Pvt. Ltd. will not be responsible for any fines, penalties that may be charged by Statutory or Regulatory authorities on account of failure of the vehicle to comply with the in-use emission standards on the vehicle not meeting any such given legal/regulatory requirement, during inspection by such authorities.
11. Emission Warranty will be applicable irrespective of the change of ownership of the vehicle provided all the conditions as laid down in this document are met from the date of original sale of the vehicle.

This Emission Warranty will be applicable only if the customer :

- (i) Observes all the important instructions and any other precautions listed in the OM for use of the vehicle.
- (ii) Under all circumstances uses lubricants and fuel as recommended by General Motors India Pvt. Ltd.
- (iii) Regularly obtains and carries out maintenance at CHEVROLET retailers as per the list in this booklet only, in accordance with General Motors India Pvt. Ltd. guidelines and enters the details in the Service Booklet.
- (iv) Immediately approaches the nearest Authorized Service Center as per the list in this booklet upon discovery of failure to comply with the In-use emission standard inspite of having maintained and used the vehicle in accordance with the instructions in the OM and having carried out such repairs and adjustments as may be required with a view to establish such compliance.

- (v) Produces the 'Pollution Under Control (PUC)' certificate valid for the period immediately preceding the test during which the failure is discovered, the test having been carried out either for obtaining a new certificate, or pursuant upon being directed by an officer as referred to in sub – rule (2) of Rule 116 of the Central Motor Vehicles Rules.
- (vi) Produces the service booklet (Owner's Manual) and all relevant bills for verification of details.
- (vii) Produces receipts covering maintenance of the vehicle as specified in the OM from the date of original purchase of the vehicle.
- (viii) Produces valid certificate of insurance & RTO registration.

Conditions under which warranty is NOT applicable:

1. Non production/availability of a valid 'Pollution under Control' certificates

as described in customer obligation (V).

2. In case the vehicle is not serviced by CHEVROLET retailers as per the list in this booklet as per the service schedule described in the maintenance chart given in the Owner's Manual.
3. A vehicle, which has been subjected to abnormal use, abuses, neglect and improper maintenance or has met with an accident.
4. Use of such replacement parts, which are not specified and approved by General Motors India Pvt. Ltd.
5. If the vehicle or parts thereof, have been altered, tampered with or modified or replaced in an unauthorized manner.
6. A vehicle on which the odometer is not functioning or the odometer has been changed or the reading of which has been changed / tampered with so that the actual mileage cannot be readily determined.

7. A vehicle, which has been used, for competitions, races, rallies or for the purpose of establishing records.
8. Examination by CHEVROLET retailers as per the list in this booklet of the vehicle shows that any of the conditions stipulated in the OM with regard to use and maintenance have been violated.
9. A vehicle, which has been run on adulterated fuel or lubricant or fuels lubricants other than those, specified by General Motors India Pvt. Ltd.

Scope and Limits:

1. This emission warranty is in addition to the product warranty for the vehicle as per the scope and limit described in the OM and all conditions described therein will apply, in addition to those exclusively stipulated in this warranty.
2. The emission warranty covers only compliance with the emission standard as specified in sub rule (2)

172 Service and Warranty

of Rule 115 of CMVR. It does not cover any other performance of these parts or routine test and consequent maintenance or adjustments to establish compliance to the in-use emission standard as applicable to the state, in which the vehicle is registered and is in use.

ANNEXURE-I

Definitions:

1. **Vehicle** : The Motor Vehicle approved for sale within India under the provisions of Central Motor Vehicle Rules, 1989 or any subsequent amendment or substitution thereof.
2. **Owner's Manual (OM)** : A document given to the customer at the time of sale of the vehicle giving guidelines on use and maintenance of the vehicle including the terms and conditions of Warranty.
3. **Maintenance** : Maintenance as per the schedule provided in the Owner's Manual by General Motors India Pvt. Ltd. including inspection, verification check, adjustment and replacement, if necessary.
4. **Service Booklet** : The scheduled service record book in Owner's Manual, which is required to be filled by CHEVROLET retailer at the time of service.
5. **Abnormal Use** : The situations when the vehicle is put to use other than that intended by General Motors India Pvt. Ltd. such as racing, overloading or use of adulterated fuel or fuel not recommended by General Motors India Pvt. Ltd.
6. **Manufacturing Defect** : Means deficiency or deviation from normal production tolerance in design, material, or workmanship in a device or system which affects any parameter, performance, or component belonging to emission control system.
7. **Product Warranty** : The manufacturer warranty as provided by General Motors India Pvt. Ltd., which covers failure of various parts and systems as per the Owner's Manual 3 years/1,00,000 kms, whichever is earlier.
8. **Emission Warranty** : Warranty for emission performance of the vehicle as determined by sub-rule (2) of rule no 115 of the Central Motor Vehicles Rules, 1989.
9. **Authorized Service Centers** : Any service facilities authorized by General Motors India Pvt. Ltd. to perform warranty repairs. This shall include all of CHEVROLET retailers that are recognised for service of subject vehicles or any other service center duly authorized by General Motors India Pvt. Ltd.
10. **Warrantable Condition** : Warrantable condition means any condition of a vehicle, which triggers the responsibility of General Motors India Pvt. Ltd. to take corrective action within the framework of emission Warranty. This however shall not include any statutory or regulatory fines or penalties.
11. **Warranted Parts** : Those components, listed as per Annexure-II.

ANNEXURE-II

List of Components Covered under Emission Warranty

S.No.	Part name
1	Catalytic Converter***
2	Exhaust manifold gasket
3	Electronic Control Module
4	Idle Air Control Motor (Gasoline)
5	Manifold Absolute Pressure Sensor (Gasoline)
6	Throttle Position Sensor (Gasoline)
7	Air Temperature Sensor
8	Oxygen sensor
9	Coolant Temperature Sensor
10	Injectors
11	Knock Sensor (Gasoline)
12	Exhaust Gas Re-circulation Valve
13	Fuel Pump

*** Catalytic Converter is covered only for emission related failures as provided under the warranty statement. Replacements if any shall not be applicable for breakage and noise problems.

Note : All the above mentioned parts are covered only if the car fails to meet the prescribed Emission norms. Any other performance problems shall be treated as not relevant to the Emission warranty.

SERVICE NETWORK

CHEVROLET SALES INDIA SALES AND SERVICE NETWORK

North zone.....	176
West zone	181
South zone	186
East zone	191
International	194

- ★ Indicates Retailer (Sales and Service)
- Indicates Chevrolet Authorized Service Center
Authorized Service Center (ASC) are authorized to carry out Periodic Maintenance (Free/Paid, Minor Running Repair) Only.

The list of authorized Retailers / ASC are mentioned herein as of April, 2014. For any change in authorized Retailers /ASC, please visit www.chevrolet.co.in.

176 Service Network

NORTH ZONE

STATE - DELHI

- * **Auto Vikas Sales & Service Pvt. Ltd.**
Workshop :
12-A, Shivaji Marg, Najafgarh Road,
New Delhi - 110015
Tel. : 011 - 42070707, 42070788
Fax : 011 - 25451004, 42070735

- * **Ganganagar Automobiles Pvt. Ltd.**
(Aarav Chevrolet)
Showroom :
11 - A, Shivaji Marg, Moti Nagar,
Opp. L & T Building, New Delhi - 110015
Tel. : 011 - 41238888

- Workshop:**
56, Rama Road, Opposite Radha Palace Banquet Hall,
New Delhi - 110 015
Tel. : 011 - 41238888, 8826292810, 8826292815

- * **Arya Automobiles**
Showroom :
Plot No. 193, Metro Pillar No. 543,
Main Rohtak Road, Mundka, New Delhi - 110041
Tel. : 011 - 8743030301 / 302
Fax : 011 - 28342887

- Workshop :**
KH-82/21/2 & 22/2, Phirmi Road, Udyog Nagar
Industrial Area, Near Mundka Metro Pillar No.547,
New Delhi - 110 041
Tel. : 011 - 28342884

- * **Go Auto Pvt. Ltd.**
Showroom :
A 231, Okhla Industrial Area, Phase-1,
New Delhi - 110020
Tel. : 011 - 41855500, 9015444555

- Workshop :**
B-25, Okhla Industrial Area, Phase-1,
New Delhi - 110020
Tel. : 011 - 41955500, 9015777888

- * **Globus Motocorp Pvt. Ltd.**
Showroom :
ZB-43 & 44/487, Zulphe Bengal, Main GT Road,
Dilshad Garden, Delhi - 110095
Tel. : 011 - 43355555

Workshop :

B-31, Jhilmil Industrial Area, Behind Jhilmil Metro
Station, New Delhi - 110095
Tel. : 011 - 43388888

- * **Metro Motors Pvt. Ltd.**
Showroom & Workshop :
Bawa Potteries Industrial Complex,
Aruna Asaf Ali Marg, Vasant Kunj - 110 070
Tel. : 011 - 41761717, 46156666

Showroom 2 :

A-2/6, Safdarganj Enclave,
Africa Avenue, New Delhi - 110 029
Tel. : 011 - 46146666 / 75

- * **Triumph Motors**

Showroom :

A-9/3 Wazirpur Industrial Area, Near Richi Rich,
New Delhi - 110052
Tel. : 011 - 47444666
Fax : 011 - 42475584

Workshop 1 :

C-13, Plot No. 65, SMA Industrial Area, GTK Road,
Opp. Jahangir Puri, Azadpur, New Delhi - 110 033
Tel. : 011 - 47444777

Workshop 2 :

G-14, Udyog Nagar, Rohtak Road, Peeragarhi,
Delhi-110041
Tel. : 011 - 42010101
Fax : 011 - 42010132

STATE - HARYANA

AMBALA

- * **Ambala Automobiles India Ltd.**
Showroom :
Ramgarh, Near Central Jail Bridge, Chandigarh Road,
Baldev Nagar, Ambala City - 134 003
Tel. : 0171 - 2543010
Fax : 0171 - 2543510

Workshop :

Barwala, Naraingarh Road, Ambala City - 134 003
Tel. : 0171 - 2678013

BHIWANI

- * **Shailesh Automobiles**
Showroom & Workshop :
Rohtak Road, Bhiwani - 127021
Tel. : 01664 - 204006/008

DADRI

- * **Shailesh Automobiles**
Showroom & Workshop :
Near Loharu Chowk, Bhiwani Road, Dadri - 127 306
Tel. : 9253660069/70

FARIDABAD

- * **Regent Automobiles Ltd.**
Showroom :
14/3, Mathura Road, Faridabad - 121 003, Haryana
Tel. : 0129 - 4088530 / 31
Fax : 0129 - 2252304

Workshop 1 :

14/5, Main Mathura Road, Faridabad - 121 003
Tel. : 0129 - 2252151 - 55, 4261200

Workshop 2 :

Plot No.57, Sector-27C, Opp. Crown Interiorz Mall,
13/1, Mathura Road, Faridabad - 121 003
Tel. : 0129 - 2577777

GURGAON

- * **Bhanu Motors Pvt. Ltd.**
Showroom:
Shop No. 4, Omaxe Wedding Mall, Main Sohna Road,
Near Subhash Chowk, Gurgaon - 122001
Tel. : 0124 - 4757777

Workshop:

Plot No. 541, Sector-37, Part-II, Gurgaon - 122001
Tel. : 0124 - 4598888

- * **Gentech Toolings Pvt. Ltd.**

Showroom & Workshop :

Plot No. 66, IDC, Opp. Sector - 14
Mehrauli - Gurgaon Road, Gurgaon - 122 001
Tel. : 0124 - 4638751 - 54, 4368787
Fax : 0124 - 4638700

- **Orix Auto Infrastructure Services Ltd.**

Workshop :

7B, Sector - 18, Maruti Industrial Area,
Gurgaon - 122 015
Tel. : 0124 - 3014700 / 701 / 719
Fax : 0124 - 3014702

- * **YAMUNA NAGAR**

Oberooi Automobiles

- * **Showroom & Workshop :**
Aggarsain Chowk, Near Gupta Palace,
Jagadhri - 135 003
Tel. : 01732 - 212030, 212010

- KURUKSHETRA**
 * **VPS Speciality Papers**
Showroom & Workshop :
 Plot No.145 &146, Industrial Area, Sector 2,
 Kurukshetra - 136 118
 Telefax : 01744 - 231050
- HISSAR**
 * **Ashwani Automotors**
Showroom & Workshop :
 9 Km Stone, OP Jindal Marg, Hissar - 125 044
 Tel. : 01662 - 220710 / 11 / 12
- JHAJJAR**
 * **Shailesh Automobiles**
Showroom & Workshop :
 Tehsil Road Jhajjar, Haryana - 124 001
 Tel. : 9253660066 / 9254171300
- JIND**
 * **Lekh Raj Motors Pvt. Ltd**
Showroom & Workshop :
 Safidon Road, opp. Brahmin Dharamsala, Jind.
 Tel. : 9992900082
- KAITHAL**
 * **Lekh Raj Motors Pvt. Ltd.**
Showroom & Workshop :
 Ambala Road, Kaithal, Haryana - 136027
 Tel. : 0174 - 6226827
- KARNAL**
 * **Aryaman Automobiles**
Showroom & Workshop :
 117/6, K.M. Milestone, Near Hotel New
 World, G. T. Road, Karnal - 132 001
 Tel. : 0184 - 2220011, 2220325
 TeleFax : 0184 - 2220025
- PANIPAT**
 * **Aryaman Motors**
Showroom & Workshop :
 Plot No 64, Sector -25, Huda Industrial Area Phase 1,
 Panipat - 132103
 Tel. : 0180 - 2666222 / 2666800
- ROHTAK**
 * **Badhwar Automobiles Pvt. Ltd.**
Showroom & Workshop :
 Sonepat Road, Rohtak - 124 001
 Telefax : 01262 - 256666

- REWARI**
 * **Vardhman Automobiles Pvt. Ltd.**
Showroom & Workshop :
 Opp. Gurudwara, Jhajhar Road, Rewari - 123 401
 Tel. : 01274 - 250440 / 251188
 Fax : 01274 - 255966
- SONIPAT**
 * **Malwa Motors Sales Pvt. Ltd.**
Showroom & Workshop :
 NH-1, 31 Km Stone, G.T. Road, Kundli,
 Sonipat - 131 001, Haryana
 Tel. : 0130 - 2219384 - 85, 2370386, 2371386
 Fax : 0130 - 2219384
- SIRSA**
 * **Padam Motors Pvt. Ltd.**
Showroom & Workshop :
 Hisar Road, Opp Traffic Police Post, Sirsa - 125055
 Tel. : 01666 - 244445
 Fax : 01666 - 244442

STATE - HIMACHAL PRADESH

- KANGRA**
 * **Himachal Autowheels Pvt. Ltd.**
(Platinum Chevrolet)
Showroom & Workshop :
 N.H 20 Kachhiary, Kangra - 176001
 Tel. : 01892 - 260600/260601
- MANDI**
 * **Ram Hari Motors Pvt. Ltd.**
Showroom & Workshop :
 Rani Ki Bain, Gutar, Mandi - 175 021
 Tel. : 01905 - 225692
 Fax : 01905 - 221691
- MANALI**
 * **Ram Hari Motors Pvt. Ltd.**
Showroom & Workshop :
 Rotang Road, Village Vishisht Vihal, PO Vashisht,
 Tehsil - Manali, Distt - Kullu, Manali - 175131
 Tel. : 01902 - 254001
- SIMLA**
 * **Rajvir Motors**
Showroom & Workshop :
 Bypass Road, Parasdass Garden, Simla - 171 001
 Tel. : 0177 - 2674284 - 6
 Fax : 0177 - 2674287

- SOLAN**
 * **Rajvir Motors**
Showroom & Workshop :
 Kalka Shimla Road, Near Mehta Market,
 Kumarhatti, Solan, Himachal Pradesh - 173 229
 Telefax : 01792 - 266338
- UNA**
 * **Bhagat Ram Motorways Pvt. Ltd.**
Showroom & Workshop :
 Una Nangal Road, Rakkah Colony, Una - 174 303
 Tel. : 01975 - 238799
 Fax : 01975 - 238699

STATE - PUNJAB

- AMRITSAR**
 * **S V Motors**
Showroom :
 Near Amritsar Gate, GT Road, Amritsar - 143001
 Tel. : 0183 - 2700102
 Fax : 0183 - 2700101
- Workshop :**
 Main GT Road, Opp. ITBP Office, Amritsar - 143001
 Tel. : 0183 - 2700201
- BATALA**
 * **Kashmir Automobiles Pvt. Ltd. (Platinum Chevrolet)**
Showroom & Workshop :
 Opp. Cambridge International School, Saidmubarak,
 Amritsar Road, Batala - 143505
 Tel.: 01871 - 241024
- BHATINDA**
 * **Padam Cars Pvt. Ltd.**
Showroom & Workshop :
 Goniara Road, 8th Mile Stone, NH-10,
 Bhatinda - 151 005
 Tel. : 0164 - 27601111 / 9216350205
 Telefax : 0164 - 2760153
- CHANDIGARH**
 * **RSA Motors Pvt. Ltd.**
Showroom:
 Plot No.5, Industrial Area, Phase-I,
 Chandigarh - 160 002
 Tel. : 0172 - 5033333,9914110606
 Fax. : 0172 - 5033338

178 Service Network

Work Shop:

Plot No. 2, Industrial Area, Phase-I,
Chandigarh – 160 002
Tel. : 0172 – 5039999,5041233,9814106962
Fax. : 0172 - 5039939

★ **Padam Motors Pvt. Ltd.**

Showroom:

182/2, Industrial Area, Phase 1, Chandigarh - 160002
Tel. : 0172 - 5212900

Workshop :

185, Industrial Area, Phase 1, Chandigarh -160002
Tel. : 0172 - 5212999

HOSHIARPUR

★ **Bedi Automobiles**

Showroom & Workshop :

Piplawala, Jalandhar Road, Hoshiarpur - 146 022
Tel. : 01882 - 329696
Fax : 01882 - 253763

JALANDHAR

★ **Aakriti World**

Showroom :

Ground Floor, Vasal Tower, Police Lines,
Opp. President Hotel, Jalandhar - 144001
Telefax : 0181 - 5003333

Workshop :

1746 Ladowali Road, Near BSF Chowk,
Jalandhar - 144001
Tel. : 0181 - 5057777

LUDHIANA

★ **Padam Cars Pvt. Ltd.**

Showroom & Workshop :

Khasra No. 279/3, G.T. Road,
Dhandari Kalan, Ludhiana
Tel. : 0161 - 2510014
Telefax : 0161 - 2510015

★ **Omni Wheels Pvt. Ltd.**

Showroom & Workshop :

Plot No 73, New Kuldeep Nagar,
Basti Jodhewal Chowk, Ludhiana - 141 007
Tel. : 0161 - 5055900
Fax : 0161 - 5055911

ROPAR

★ **Padam Cars Pvt. Ltd.**

Showroom & Workshop :

Chandigarh Road, Nangal Chowk, Ropar - 140 001
Telefax : 01881 - 500099

MOGA

★ **Padam Cars Pvt. Ltd.**

Showroom & Workshop :

Near Majestic Resorts, Ferozepur Road,
Moga - 142 001
Tel. : 01636 - 225755

NAWASHAHAR

★ **Aakriti World**

Showroom & Workshop :

Chandigarh Road, Nawashahar, Punjab - 144 514
Tel. : 01823 - 285656
Telefax : 01823 - 285858

PATIALA

★ **Padam Cars Pvt. Ltd.**

Showroom & Workshop :

Main Patiala - Rajpura Road,
Opp. Caspa Resort, Bahadurgarh, Patiala - 147 001
Tel. : 0175 - 2663813 - 14, 9217100905 - 9
Fax : 0175 - 2663828

PATHANKOT

★ **Kashmir Automobiles Pvt. Ltd.**

Showroom & Workshop :

Simbel Chowk, Dalhousie Road, Pathankot - 145 001
Tel. : 0186 - 2257022 - 24

SANGRUR

★ **Padam Cars Pvt. Ltd.**

Showroom & Workshop :

College Road, Opp. Kamal Palace, Sangrur - 148001
Tel. : 9216350134, 9216911461

STATE - RAJASTHAN

AJMER

★ **Rajdeep Autowheels (P) Ltd.**

Showroom :

12-15, ASC Road, Vaishali Nagar, Ajmer - 305001
Tel. : 0145 - 2628989 / 2625116

Workshop :

Khasara No-319 Kankarda Bhumaboy, NH-8,
Jaipur Road, Ajmer - 305001
Tel. : 0145 - 2788192 / 93 / 2788222 / 23

ALWAR

★ **Triumph Motors**

Showroom & Workshop :

Old Delhi Road, Near Jhankar Hotel, Alwar - 301 001
Telefax : 0144 - 3047571 - 78

BHILWARA

★ **Rajdeep Autowheels (P) Ltd.**

Showroom & Workshop :

Payal Resort, Ajmer Road, Bhilwara - 311001
Tel. : 01482 - 265164

★ **BIKANER**

Sunehri Cars

Showroom & Workshop :

Plot No. 15, Transport Nagar,
NH-15, Ganganagar Road, Bikaner - 334 001
Tel. : 8003399060 / 66 / 69

BANSWARA

★ **Atharva Motors Pvt. Ltd.**

Workshop :

Janamedi, Udaipur Road, Banswara - 327001
Tel. : 02962 - 250227

CHITTORGARH

★ **Atharva Motors Pvt. Ltd.**

Showroom :

Plot No. 86, Kabir Colony, Bhilwara Road,
Chittorgarh - 312001
Tel. : 01472 - 247598
Fax : 01472 - 247598

Workshop :

Near Saint Paul's School, Opp. Rajasthan State
Seed Corp., Nimbhera Road, Chittorgarh - 312001
Tel. : 01472 - 240598

★ **CHOMU**

Triumph Motors

Showroom & Workshop :

Near Radha Soami Bagh, Jaipur Road,
Chomu - 303702
Tel. : 0142 - 3304000

★ **JAIPUR**

Triumph Motors

Showroom I :

Corporate Tower, A-1, Jawahar Lal Marg,
Jaipur - 302015
Tel. : 0141 - 4057575
Fax : 0141 - 4057500

Showroom 2 :

C7D, Sawai Jai Singh Highway,
Bani Park, Jaipur - 302016
Tel. : 0141 - 4122222
Fax : 0141 - 4122233

Workshop 1 :

E-109A, Sitapura Industrial Area, Jaipur - 302 004
Tel. : 0141 - 5122333, 5113636, 5143737,
5122797, 5122798, 5143636, 4090409
Fax : 0141 - 5122552

Workshop 2 :

E-12B, Vishwakarma Ind. Area, Road No. 01,
Jaipur - 302013
Tel. : 0141 - 4255555

Workshop 3 :

E1 - 2295, Ramchandrapura Industrial Area,
Sitapura Ext, Jaipur - 302022
Tel. : 0141 - 4090409

JHUNJUNU

★ **Triumph Motors**

Showroom & Workshop :

G1-8, 9 & H1-16,17, Phase - 2, RIICO Industrial Area,
Jhunjunu - 333001
Tel. : 01592 -203163, 250001-3, 250145, 250146

JODHPUR

★ **Atharva Motors Pvt. Ltd.**

Showroom :

27/27A, Light Industrial Area,
Near Shastri Circle, ITI Road, Jodhpur - 342 003
Tel. : 0291 - 3048491

Workshop :

E-711, Mia Bsn, IInd Phase,
Behind Krishna Dharam Kanta, Jodhpur - 342 005
Tel. : 0291 - 3048217 - 22
Fax : 0291 - 3048223

KOTA

★ **Triumph Motors**

Showroom & Workshop :

E - 137C, Road No. 5,
Indraprastha Industrial Area, Kota
Tel. : 0744 - 2372333, 2372666

PALI

★ **Atharva Motors Pvt. Ltd.**
Showroom & Workshop :
Opp. Krishi Mandi, Jodhpur Road, Pali - 306401
Tel. : 9414060104

SIKAR

★ **Triumph Motors**
Showroom & Workshop :
Near Circuit House, NH-11, Jaipur Sikar Road,
Sikar - 332001
Tel. : 01572 - 245971

SRI GANGANAGAR

★ **Sunehri Cars**
Showroom & Workshop :
6th Km Stone, Surat Garh Road, NH-15,
Sri Ganganagar
Tel. : 8003399070 / 71

UDAIPUR

★ **Atharva Motors Pvt. Ltd.**
Showroom & Workshop :
A-83, Mewar Industrial Area, Madri, NH-8,
Ahmedabad Bye Pass, Udaipur - 313 002
Tel. : 0294 - 3002730, 3002769
Fax : 0294 - 2490108

STATE - UTTAR PRADESH

ALIGARH

★ **Jattari Automobile**
Showroom & Workshop :
300 Mtr. From, Bharat Petrol Pump,
Khair By Pass Road, Aligarh - 202001
Tel. : 8938802229, 8938802214

ALLAHABAD

★ **Eldce Motors**
Showroom :
Eldce Enclave, 2, S.P. Marg, Civil Lines,
Allahabad-211 001
Tel. : 0532 - 2560743, 44

Workshop :

Kanodia Mill Compound 1, Luker Ganj,
Allahabad - 211 001
Tel. : 0532 - 2616368

AGRA

★ **Kalyan Auto Sales**
Showroom & Workshop :
Opp. Bhagwati Dhaba, Near New Sabji Mandi,
Sikandra, Agra - 282 007
Tel. : 0562 - 2640460 / 62 / 63
Fax : 0562 - 2640461

BAREILLY

★ **VAT Motors Pvt. Ltd.**
Showroom & Workshop :
4.5 KM, Rampur Road, CB Ganj, Bareilly - 243 001
Tel. : 0581 - 2560741
Fax : 0581 - 2560731

FAIZABAD

★ **Megha Auto (I) Pvt. Ltd.**
Showroom & Workshop :
Lucknow Bypass Road, Sahadatganj,
Faizabad - 224 001
Tel. : 09839099210

GORAKHPUR

★ **United Motors**

Showroom :

Kasia By-pass Road, Near Dr. Riyaz Ortho Hospital,
Mohaddipur, Gorakhpur -273001
Tel.: 0551-2201667
Fax.: 0551-2338299

Workshop :

Saryu Nahar Colony, Singharia,
Gorakhpur-Deoria Road, Gorakhpur - 273008
Tel.: 0551-2270231

GHAZIABAD

★ **Shiva Motors**

Showroom & Workshop :

28/3/5, Site - IV, Industrial Area, Sahibabad, Ghaziabad
Tel.: 0120 - 3008600 / 605 / 631 / 632 / 635 / 636
Fax: 0120 - 3008643 / 45 / 48 / 49 / 50

Workshop 2 :

58/3, Site 04, Sahibabad, Ghaziabad - 200300
Tel. : 0120 - 4558765

JHANSI

★ **Sri Venkateshwar Autocare Pvt. Ltd.**

Showroom & Workshop :

Jhansi Kanpur Road, Goramachhiya, Jhansi - 284001
Tel. : 0510 - 2371144, 6450158

180 Service Network

- KANPUR**
★ **Cross Road Auto Pvt. Ltd.**
Showroom :
40, Government Industrial Estate,
Opp. Sindhi Colony, Fazal Ganj, Kanpur - 208 012
Tel.: 0512 - 2221276 / 2220043
- Workshop 1 :**
C-15A, Panki Industrial Area, Site-1, Kanpur - 208012
Tel.: 0512 - 2691293, 2691377
- Workshop 2 :**
122/236, A-1 & C-1, Fazalganj,
Near Sangam Talkies, Kanpur - 208012
Tel.: 8009461111
- ★ **Romi Motors Pvt. Ltd.**
Showroom :
14/63, Civil Lines, Kanpur - 208 001
Tel.: 0512 - 3224703
- Workshop :**
120/192 (4), Lajpat Nagar,
Near Mariampur Crossing, Kanpur - 208 012
Tel.: 0512 - 3224701 / 3224702
- LUCKNOW**
★ **Megha Auto (I) Pvt. Ltd.**
Showroom & Workshop :
10/C/P/5, Ring Road, Vikasnagar,
Opp. Jagrani Hospital, Lucknow - 226 020
Tel.: 0522 - 4057999 / 4007977 / 2330180
- Workshop 2:**
Mishipur Depot, Near Sanatan Cold
Storage, Kursi Road, Lucknow - 226 026
Tel.: 0522 - 2890631
- ★ **MATHURA**
Kalyan Auto Sales
Showroom :
NH-2, Agra-Mathura Road, Mathura
Tel.: 9927000967
- ★ **MEERUT**
Vardajyoti Automobiles Pvt. Ltd.
Showroom & Workshop :
Madhuban Cinema Bldg., Madhuban Colony,
Baghpath Road, Meerut - 250 002
Tel.: 0121 - 2404005 - 08
Fax: 0121 - 2404009

- MORADABAD**
★ **Sigma Motors Pvt. Ltd.**
Showroom & Workshop :
Near Radhakrishna Mandir,
Delhi Road, Moradabad - 244001
Tel.: 0591-2550100-05, 7351007701-05, 7351003805
- MIRZAPUR**
★ **Saraswati Industries**
Showroom & Workshop :
Pili Kothi, Station Road, Mirzapur - 231001
Tel.: 05442 - 223923
- NOIDA**
★ **Shiva Motors**
Showroom :
G-24, Sector 11, Noida - 210301
Tel.: 0120 - 3920150 / 158
- Workshop :**
C-80/81A, Sector - 8, Noida
Tel.: 0120 - 3359807 / 813
- SAHARANPUR**
★ **DPM Autosales**
Workshop :
Ambala Road, Near Badi Nahar, Saharanpur
Tel.: 0135 - 2640877
- ★ **SHAHJAHANPUR**
VAT Motors Pvt. Ltd.,
Showroom & Workshop :
Axis Chevrolet, 4.5 Km, Bareilly Road, Mauzampur,
Shahjahanpur - 242001
Tel.: 8795030111
- ★ **VARANASI**
Vinayak Automotive Pvt. Ltd. (Vinayak Chevrolet)
Showroom & Workshop :
Adjacent to Essar Petrol Pump,
Jagatpur, Rohania, Varanasi - 221313
Tel.: 7703003320, 7703003330, 7703003321, 7703003333
- STATE - UTTARAKHAND**
- ★ **DEHRADUN**
DPM Autosales
Showroom & Workshop :
Mohabewala Industrial Area,
Saharanpur Road, Dehradun
Tel.: 0135 - 2642051 / 52 / 53
Fax: 0135 - 2642054

- ★ **HALDWANI**
Analysis Motors
Showroom :
Rampur Road, Near Sushila Tewari Hospital,
Haldwani - 263139, Distt. Nainital
Tel.: 9258071041, 9258071009
- Workshop :**
7.5km Stone, Gora Padav, Bareilly Road,
Haldwani-263641
Tel.: 05946 - 232050
- ★ **RUDRAPUR**
Analysis Motors
Showroom :
Near Axis Bank, Nanital Road, Rudrapur - 263 153
Tel.: 9258071011
- Workshop:**
Industrial Area Kiccha Bypass Road,
B-27, Rudrapur - 263153
Tel.: 05944 - 243836

STATE - JAMMU & KASHMIR

- JAMMU**
★ **K. C. Motors**
Showroom & Workshop :
NH-1, Bypass Road, Jammu - 180 004
Tel.: 0191 - 2465769 / 59, 2460829
Fax: 0191 - 2476660
- ★ **RS PURA**
K. C. Motors
Showroom & Workshop :
Bagha Marh, RS Pura, Jammu
Tel.: 01923 - 252809
Fax: 01923 - 252809
- ★ **SRINAGAR**
K. C. Motors
Showroom & Workshop :
By Pass Road, Hyderpora, Srinagar - 190 014
Tel.: 0194 - 2443188

WEST ZONE

STATE - GOA

- ★ **VASCO-DA-GAMA**
Subrai Motors Pvt. Ltd.
Showroom & Workshop :
F L Gomes Road, Vasco-Da-Gama, Goa - 403 802
Tel. : 0832 - 2517421 / 22
Fax : 0832 - 2513924

STATE - GUJARAT

- ★ **AHMEDABAD**
Gallops Motors Pvt. Ltd.
Showroom & Workshop :
Near JCB Service Station, S.G. Highway,
Sarkhej, Ahmedabad - 380 015
Tel. : 079 - 2474346, 39835544, 39835501
Fax : 079 - 39835588
- Showroom 2 :**
A/8,9,10,11,12,13 & 14, Radhe Shopping Mall,
Khokhra, Maninagar, Ahmedabad
Tel. : 079 - 32941862 / 32440235
- Showroom 3 :**
Vedas Ground Floor, Opp SBI Saijpur Branch,
NH 8 Naroda, Patia Cross Road, Ahmedabad - 382325
Tel. : 079 - 22820106
- Workshop 2 :**
Opp. Amraivadi Post Office, Near Hatkeswar Circle,
Maninagar, Ahmedabad - 380 026
Tel. : 079 - 30486501 / 02 / 03
- ★ **ANAND**
Shree Gopinathji Agencies
Workshop :
Survey No. 570 - A/2, Near Indira Statue,
Lambhavel Road, Anand - 388 001
Tel. : 02692 - 247979 / 247878
- ★ **BHARUCH**
Shree Gopinathji Agencies
Showroom & Workshop :
Beside K.U & Company Petrol Pump,
NH-8, Village Vadadala, Bharuch - 392 015
Tel. : 02642 - 654245, 291303, 654845
Telefax : 02642 - 231584

- ★ **BHAVNAGAR**
V Raj Motors
Showroom & Workshop :
Plot No. 150, Near Press Quarter,
Opp. Maruti Showroom, Bhavnagar-Rajkot Road,
Chitra, Bhavnagar - 364 003
Tel. : 0218 - 2444590, 2444445
- ★ **BHUJ**
Cargo Motors
Showroom & Workshop :
Plot No. 10, Survey No. 29/1,
Bhuj - Mirzapur Road, Bhuj - 370001
Tel. : 02832 - 654191 / 654192
- ★ **GANDHIDHAM**
Cargo Motors
Showroom & Workshop :
NH-8A, Kandla Port Road, Gandhidham - 370 201
Tel. : 02833 - 654370, 653317, 9825611692
- ★ **GODHRA**
Shree Gopinathji Agencies
Showroom & Workshop :
Moonlight Cinema Compount, Vavdi,
Godhra - 389 001
Tel. : 02672 - 645828, 265270, 265271
- ★ **GANDHI NAGAR**
Gallops Motors Pvt. Ltd.
Showroom & Workshop :
Near Nigam Petrol Pump, Rajshree Cinema Road,
Sector-21, Gandhinagar - 382 010
Tel. : 0232 - 30516107
- ★ **HIMMATNAGAR**
Gallops Motors Pvt. Ltd.
Showroom & Workshop :
Near Motipura Circle, Opp. S.T. Workshop,
Shamlaji Highway, Himmatnagar - 383 001
Tel. : 02772 - 229525, 229524, 308000, 308001
- ★ **JAM NAGAR**
Gallops Motors Pvt. Ltd.
Showroom :
Jamnagar - Rajkot Highway, Hapa,
Opp. Tata IB Motors, Jamnagar
Tel. : 0288 - 3216060

Workshop :
Jamnagar to Rajkot Highway, 8 - Happa,
Jamnagar - 320 120
Tel. : 0288 - 3921194 - 98

- ★ **MEHSANA**
Gallops Motors Pvt. Ltd.
Showroom & Workshop :
Opp. Wide Angle, Nagalpur Highway,
Mehsana - 384 002
Tel. : 02762 - 241010, 302401 / 02 / 06
Fax : 02762 - 245151

- ★ **NAVSARI**
Monarch Motors
Showroom & Workshop :
Mahalaxmi Estate, Near Bhana Petrol Pump,
Near Grid Char Rasta, N.H. No. 8, Navsari - 396424
Tel. : 02637 - 265788 / 265599

- ★ **PALANPUR**
Gallops Motors Pvt. Ltd.
Showroom & Workshop :
Survey No. 525/1, Palanpur – Delhi Highway,
Near Palanpur - Deesa Char Rasta, Palanpur - 385001

- ★ **RAJKOT**
Gallops Motors Pvt. Ltd.
Showroom & Workshop :
Survey No. 219/220, Opp. Parin furniture,
Next to Jay Ganesh, AT & PO,
Kotharia Gondal Highway, Rajkot - 360 003
Tel. : 0281 - 3205151, 2370006 / 8 / 9 / 10,
3983400, 3983407

Showroom 2:
Ground Floor, Fortune Square, Jalaram Street,
Near Kotecha Circle, Kotecha, Rajkot - 360001
Tel. : 9909992033

- ★ **SURAT**
Empire Cars Pvt. Ltd.
Showroom & Workshop :
Plot No. 3, Near Rangoli Hotel, Rundh,
Dumas Road, Surat - 395007
Tel. : 0261 - 6713300 / 33

182 Service Network

* **Monarch Cars Pvt. Ltd.**

Showroom:

Umia Nagar Society,
Near Shree Choshath Joganiya Mata Mandir,
Udhna Magdalla Road, Surat-394210
Tel.: 0261-2720481, 2720482, 09825274707

Workshop :

Next To Sameeti School, Patel Nagar Circle,
Udhna Gam, Surat - 394210
Tel.: 0261-3091001

* **Nanavati Motors**

Showroom:

Orchid Tower, Opp Intercity Township,
Puna Kumbharia road, Surat-395010
Tel.: 9879114447

Workshop :

Opp. SBI Bank, Puna Patiya,
Puna Kumbharia Road, Surat-395010
Tel. : 0261-6456449/429/430
Fax : 0261-2647771

SURENDRA NAGAR

* **Gallops Motors Pvt. Ltd.**

Showroom & Workshop :

Plot No. 267, GIDC Vadhan, Opp. Market Yards,
Near Rekha Bearings, Surendra Nagar
Tel. : 02752 - 321542 - 43

VAPI

* **Desai Automobiles**

Showroom & Workshop :

At & Po : Balitha, Near Woodland Hotel,
National Highway No. 8,
Taluka Pardi, Vapi, Valsad - 395 015
Tel. : 0260 - 6531783, 2400250 - 51
Fax : 0260 - 2426525

* **VADODARA**

Shree Gopinathji Agencies

Showroom & Workshop :

Opp. Gujarat Elec. Board Sub Station,
(Near Prakuti Resort), Chhani, Baroda - 390002
Tel. : 0265 - 2761105 / 06

Showroom & Workshop 2 :

R. S. No. 7, Opp. Atladra Railway Station,
Atladra, Vadodara - 390 012
Tel. : 0265 - 2681050, 1060, 0187, 1010, 1020
Fax : 0265 - 2681050, 2354984

Showroom & Workshop 3 :

3/A, Sahajanand Industrial Estate,
Munjmahuda, Akota, Vadodara - 390 020
Tel. : 0265 - 2681010, 2681020, 2359898, 2334109
Fax : 0265 - 2681050, 2681060

STATE - MADHYA PRADESH

BHOPAL

* **Super Cars Ltd.**

Showroom & Workshop :

Plot No. 21 Sector G, Govindpura Industrial Area,
J.K. Road, Bhopal - 462 021
Tel. : 0755 - 4028400, 4228201
Fax : 0755 - 4228203

* **Varenayam Motors**

Showroom & Workshop :

189, Angoori Bagh, Jinsi Road, Bhopal - 462008
Tel. : 0755 - 2575288 / 299 / 300
Fax : 0755 - 2579918

CHHINDWARA

* **Sunshine Motors**

Showroom & Workshop :

College Road, Lalbagh, Chhindwara- 480001
Tel. : 0716 - 244125, 244129, 244193 / 194
Fax : 0716 - 244126

GWALIOR

* **Sumedha Vehicles Pvt. Ltd.**

Showroom & Workshop :

Opp. Jhansi Road Police Station,
Jhansi Road, Gwalior - 474 009
Tel. : 0751 - 2422067, 4015789, 3291856
Fax : 0751 - 2348024

INDORE

* **Super Cars Ltd.**

Showroom :

Saket Tower - 3A, Ratlam Kothi,
Near Geeta Bhavan Square, AB Road, Indore - 452 001
Tel. : 0731 - 4700053, 54
Telefax : 0731 - 4700052

Workshop :

49, United Compound, Iasudiya Mori,
Dewas Naka, Indore
Tel. : 0731 - 470055, 56, 57
Fax : 0731 - 470054

* **Chhabra Autolink Pvt. Ltd.**

Showroom :

Plot no.-10 Vishnupuri Main, Near Medisquare
Hospital, Indore - 452001
Tel : 0731- 4267800

Workshop :

Plot no.- 11/11.11/12, Survey no.- 26, Gram Palada,
Khandwa Road, Indore - 452011
Tel : 0731 - 6656000

* **JABALPUR**

Oriental Motors

Showroom & Workshop :

497, Karneta, Near Padwar Kala,
Katangee Bye Pass Road, Jabalpur - 482 003
Tel. : 0761 - 3250007, 3260002, 3250003, 3290001
Fax : 0761 - 4027011

* **KHANDWA**

Bedi Motors

Showroom & Workshop :

Gram Kehmapur, Indore Road, Khandwa - 450 001
Tel. : 0733-2244075

* **RATLAM**

Super Cars Ltd.

Showroom & Workshop :

Jaora Road, Near RTO Office, Ratlam - 457 001
Tel. : 07412 - 260040

* **SATNA**

Oriental Motors

Showroom :

Virat Nagar Colony, Pateri, Panna Road, Satna - 485 001
Tel. : 07672 - 229495

Workshop :

27, Industrial Area Near Union Floor, Rewa Road,
Satna - 485001
Tel. : 7672 -252763

STATE - MAHARASHTRA

- ★ **AHMEDNAGAR**
Saideep Cars Pvt. Ltd.
Showroom & Workshop :
 Survey No. 55/1B/2/1, Nagar Manmad Road,
 Ahmednagar - 414 111
 Tel. : 0241 - 2779225 - 7
 Fax : 0241 - 2779228
- ★ **AKOLA**
Star Motors
Showroom & Workshop :
 9/1, Geeta Nagar Near, Alankar Petrol Pump,
 Akola - 444 005
 Tel. : 07242800087 / 7350008428
- ★ **AMRAVATI**
Star Motors
Showroom & Workshop :
 Plot No. 8, Navathe Square Bandnera Road, Amravati
 Tel. : 0721 - 2510199, 9921008861, 7350008426
- ★ **AURANGABAD**
Soham Motors Pvt. Ltd.
Showroom & Workshop :
 Plot No. 2 & 3, N-2, Mukundwadi, Airport Road,
 Aurangabad - 431 003
 Tel. : 0240 - 6603769, 6503769
- Workshop 2 :**
 Plot No. 28 & 29, MIDC Chikalhana, Aurangabad
 Tel. : 0240 - 2489411, 2474342 - 6
- ★ **BARAMATI**
Mota Automotive Pvt. Ltd.
Showroom & Workshop :
 41 / 1 / B / 17, Nira Road, Kasba, Tehsil - Baramati,
 Dist - Pune - 413102
 Tel. : 021112 - 222212, 220212
- ★ **CHANDRAPUR**
ND Cars Pvt. Ltd.
Showroom & Workshop :
 Gajaman Maharaj Mandir Square, Bapat Nagar,
 Nagpur Road, Chandrapur - 442401
 Tel. : 07172 - 646344/22

- ★ **DHULE**
Jitendra Wheels Pvt. Ltd.
Showroom & Workshop :
 P-62, Behind Hotel Manas, MIDC Avdhan,
 Dhule - 424 001
 Tel. : 02562 - 281222 / 232
- ★ **JALGAON**
Soham Motors Pvt. Ltd.
Showroom & Workshop :
 93/1, MIDC, RL Square Aurangabad Road,
 Jalgaon - 425003
 Tel. : 0257-2211151, 2270085
- ★ **KOLHAPUR**
Unique Automobiles
Showroom & Workshop :
 122/1, Pulachi Shirol, Opp. Sangli Phata,
 Kolhapur - 416 122
 Tel. : 0230 - 2461518 - 19
 Fax : 0230 - 2461520
- Showroom 2 :**
 Ayodhya Park, Opp. Sangam Talkies,
 Kavala Naka, Kolhapur - 416 001
 Tel. : 0231 - 2535315, 2535425
 Fax : 0231 - 2535615
- ★ **LATUR**
Ajinkya Cars Pvt. Ltd.
Showroom & Workshop :
 Barshi Road, Near Bidave Engineering College,
 Beside Pramod Petrol Pump, Latur - 413531
 Tel. : 02382 - 222600
- ★ **MUMBAI**
Ashstavinayak Auto Pvt. Ltd.
Showroom :
 D Mall, Off Veera Desai Road, Andheri (West),
 Mumbai - 400 053
 Tel. : 022 - 66488888
 Fax : 022 - 66488880
- Workshop :**
 Ram Mandir Road, Somani Gram,
 Next to Central Warehouse Corporation,
 Oshiwara, Goregaon (West), Mumbai - 400 051
 Tel. : 022 - 26765555

- ★ **AVK Automart Pvt. Ltd.**
Workshop :
 Fida Hussain Industrial Estate,
 Near Samrat Hotel, Pandurang Wadi Road,
 Mira Road (West), Mumbai - 401 104
 Tel. : 022 - 28453178, 28455507, 28453564
- ★ **Nikhil Automobiles Pvt. Ltd.**
Showroom & Workshop 1 :
 A 70, TTC Industry Area, Thane Belapur Road,
 Kharghar, Near ICI Color Company,
 Khoparkhane West, Navi Mumbai - 400 709
 Tel. : 022 - 27780801, 40708888
 Fax : 022 - 40708899, 27780805
- Showroom 2 :**
 264-265, Vaswani Chambers, Opp. Old Passport
 Office, Pravhadevi, Mumbai - 400 025
 Tel. : 022 - 434594444, 24221711-12
 Fax : 022 - 24222713
- Workshop 2 :**
 C/o Bharat Tiles & Marbles Ltd.,
 Jaibhimnagar, Dharukhana Road, Reay Road (East),
 Near Sujala Hotel, Mumbai - 400 010
 Tel. : 022 - 64560303, 23774514 / 15 / 16
 Fax : 022 - 23774505
- Workshop 3 :**
 Plot No. D - 238 - A, TTC Industrial Area,
 MIDC Shiravane, Nerul, Navi Mumbai - 400 706
 Tel. : 022 - 43448800
- Workshop 4 :**
 RC 27 F - O/W/P23, Brick Bunder Sewri,
 Haybunder Road, Kala Chowki, Mumbai - 400033
 Tel. : 022 - 64560303
- ★ **JMD VFM Cars India Pvt. Ltd.**
Showroom :
 47I A- 1st Floor KK Square, Adjoining Solitaire
 Corporate Park, Near P&G Plaza Andheri (East),
 Mumbai - 400099
 Tel. : 022- 28565900/02/03
- Workshop :**
 Plot No. 48-A, Khairani Road, Opp. Gundecha
 Chambers off, Sakivihar Road, Sakinaka Andheri
 (East), Mumbai - 400072
 Tel. : 022- 28565900/01/02

184 Service Network

- * **NASIK**
Jitendra Wheels Pvt. Ltd.
Showroom & Workshop :
B-88, Arihant Plaza, MIDC, Ambad, Next to Hotel Taj,
Mumbai - Agra Highway, Nasik - 422 010
Tel. : 0253 - 2384432 / 632 / 832, 6636666, 6637777
Fax : 0253 - 2384532
- * **NAGPUR**
Star Motors
Showroom & Workshop :
44 / 4, Wahajara, Kamptee Road,
NH - 7, Nagpur - 440 026
Tel. : 0712 - 6507836/37, 6507916, 6461503 / 04
Fax : 0712 - 2632429
- * **Tajshree Motors Pvt. Ltd.**
Showroom :
Plot No. 1 Hindustan Colony, Wardha Road,
Nagpur - 440 002
Tel. : 0712 - 2250242 / 2250243 / 2250244
- Workshop :**
Plot No. 679, Ghat Road,
Near Cotton Market Square, Nagpur - 440 018
Tel. : 0712 - 2734466 / 2734467
- * **NANDED**
Bafna Automotives
Showroom & Workshop :
Gut No. 235, Pimpalgaon (Mahadeo),
Nanded - Akola Road, Nanded - 431 607
Tel. : 02462 - 274069 / 652099, 311102
- * **PUNE**
Platinum Chevrolet
Showroom & Workshop 1 :
Sr No 45/1/B/A, Shankarseth Road, Gutkewadi,
Pune - 411037
Tel. : 020 - 26440029
- Showroom & Workshop 2 :**
Survey No 5/4, Najhate Nagar, kalewadi Main Road,
Thergaon, Pune - 411033
Tel. : 020 - 66326600, 66326632, 66326666
- * **Singh Cycle & Motor Co.**
Showroom 1 :
S. No. 38/4, Krishna Complex, Hadapsar Bypass
Road, Near Radisson Hotel, Kharadi, Pune - 411 014
Tel. : 020 - 32419385 / 32319526

- Showroom 2 :**
ICC Trade Centre, Showroom No. 4, Survey No. 403
A/2, Senapati Bapat Road, Pune - 411016
Tel. : 020 - 25666941 / 2 / 3 / 4
- Workshop 1 :**
Reality Warehousing Pvt. Ltd., Gate No. 1337 / 1,
Pune Nagar, Wagholi, Pune - 412 307
Tel. : 020 - 46609999
- Workshop 2 :**
Patel Tiles Compound, Sr.No. 42/1, Shivaji Nagar,
Behind ST Bus Stand, Pune - 411005
Tel. : 020 - 32424202, 65270809, 7774010500
- * **SATARA**
Unique Automobiles
Showroom & Workshop :
41, Mutha Colony, Sadar Bazar, Satara - 416 002
Tel. : 09623225299
- * **SOLAPUR**
Gandhi Wheels
Showroom :
163/1, Railway Lines, Solapur - 413 001
Telefax : 0217 - 2629400
- Workshop :**
Vale, Pune Road, Solapur - 413 001
Tel. : 0217 - 2500800
- * **SANGLI**
Unique Automobiles
Showroom :
442-3, Kulkarni Complex, 100 feet road,
South Sivaji Nagar, Sangli - 416 416
Tel. : 0233 - 2326544
Fax : 0233 - 2326594
- Workshop :**
Kulkarni Complex, 100 Feet Road,
Near MSEB Sub-Station, Sangli - 416 416
Tel. : 0233 - 2326544
Fax : 0233 - 2326594

- * **YAVATMAL**
SARAS MOTORS
Pobaru Marketing & Agencies Pvt. Ltd.
Showroom :
Shop No. 5,6,7,8 Udhog Bhavan,
Dharwha Road, Yavatmal - 445 001
Tel. : 07232 - 255991
Fax : 07232 - 255992
- Workshop :**
Block No. B-16 MIDC (Lohara), Yavatmal - 445001
Tel. : 07798883816
Fax : 07232 - 255992
- * **THANE**
SC Auto Corporation
Showroom:
Modi House, Opp. to LIC Building, Naupada,
Eastern Express Highway, Thane (West),
Thane - 400 602
Tel. : 022 - 67610000
Fax : 022 - 67610209
- Workshop :**
Pioneer Estate Corporation, 133-134, Pokhran Road
No.2, Opp. Oswal Park, Thane (West) - 400601
Tel. : 022 - 66040000
Fax : 022 - 66040102
- * **Angel Auto World Pvt. Ltd.**
Showroom & Workshop 1 :
Grishma garden, Gokhivare, Vasai East, Thane,
Mumbai (Vasai) - 401208
Tel. : 0250-6453030 / 6061777
- Showroom & Workshop 2 :**
J-176, MIDC, Tarapur Road,
Boisar (West) - 401505
Tel. : 02525 - 655454 / 655353
- * **Nikhil Automobiles Pvt. Ltd.**
Showroom & Workshop :
Survey No.6, Hissa No.6, Manpada Gaon,
Kalyan Shill Road, Dombivali (East) - 421204.
Tel. : 0251-3048888/3048899

STATE - CHATTISGARH

BILASPUR

- * **Vardhaman Motors**
Showroom & Workshop :
Near Uslapur Railway Crossing, Mungeli Road,
Sakri, Bilaspur
Tel. : 07752 - 217934 / 217935

RAIPUR

- * **Vardhaman Motors**
Showroom & Workshop :
9/1, Mahoba Bazar, GE Road, NH-6,
Kumhari Dist. - Durg, Raipur - 492 001
Tel. : 7489177999, 7883221999

Showroom 2 :

Ashoka Millenium, Ring Road,
Raipur - 492 0011
Tel. : 7714030104, 7712410008

SOUTH ZONE

STATE - ANDAMAN & NICOBAR

PORTBLAIR

- * **Group Engineers**
Showroom :
Prem Nagar Junction, (SY No 1394/1),
Haddo Post Port Blair - 744102
Tel. : 03192 - 230301, 242901

Workshop :

Opp Womens Working Hostel, Dollygunj,
Port Blair, Junglight Post, Portblair - 744103
Tel. : 03192 - 253044 / 253011

STATE - ANDHRA PRADESH

ANANTPUR

- * **Dheeraj Motors**
Showroom & Workshop :
Survey No. 239/2C & 241/1C, Kakkapali Gram
Panchayat, Opp. Sakshi News Paper Office,
Anantapur - 515 001

BHIMAVARAM

- * **Orange Auto Pvt. Ltd.**
Showroom & Workshop :
Door No. 2-25, # 6, Near Bharath petroleum bunk,
Undi Road, Bhimavaram - 534 202
Tel. : 9052781234 / 905224678

CHITTOOR

- * **M.G. Brothers Automobiles (P) Limited**
Showroom & Workshop :
NH 4, Near Iruvaram Check Post, Chittoor - 517 001
Tel.: 92470 0003, 9247000027

GUNTUR

- * **Fusion Motors**
Showroom & Workshop :
Plot No. 296 & 297, Opp. Sarvani Diesel Engineering,
Autonagar Main Road, Autonagar, Guntur - 522001
Tel. : 0863 - 6454545

HYDERABAD

- * **Kun Automobiles (P) Ltd.**
Showroom & Workshop 1 :
Plot No. 74, Snehapuri Colony, Near Andhra Bank,
Nagole Main Road, Nagole, Hyderabad - 500 035
Tel. : 040 - 24220013, 44886666, 44886767/700/701
Fax : 040 - 24220313

Showroom 2 :

House No. 1-3-1045, Viceroy Hotel Lane,
Kawadiguda Road, Hyderabad - 500 080
Tel. : 040 - 27532385 - 89
Fax : 040 - 27532384

Showroom 3 :

Plot No.3 & 4, Ravi Colony, Main Road,
Kondapur, Hyderabad - 500084
Tel. : 040 - 45469999 / 89 / 79 / 69
Fax : 040 - 45469959

Workshop 2 :

1-8-670, Azamabad, RTC 'X' Road, Hyderabad-500020
Tel. : 040 - 27668678 / 27668761
Fax : 040 - 27668632

Workshop 3 :

Plot No. 21, Mini Industrial Estate,
Hafeezpet Road, Kondapur, Hyderabad - 500049
Tel. : 040 - 31906677

Workshop 4 :

Plot No.37, Survey No.45, Vignan Junior College
Road, Kundapur, Hyderabad - 500081
Tel. : 040 - 31906699

- * **Orange Auto Pvt. Ltd.**

Showroom 1 :
6-3-249/3, Abhinandan Towers, Road No. 1,
Banjara Hills, Hyderabad - 500 034
Tel. : 040 - 66515555
Fax : 040 - 66469999

Workshop 1 :

B-45/46, Industrial Estate, Near Andhra Bank
Sanatnagar, Hyderabad - 500 018
Tel. : 040 - 66265555 / 66269999

Showroom & Workshop 2 :

16-2-705/1/1, Malakpet, Opp. Srukruka Market,
Hyderabad - 500 036
Tel. : 040 - 66815555
Fax : 040 - 66179999

Showroom & Workshop 3 :

A2, Balanagar Techno Craft Industrial Estate,
Balanagar, Hyderabad - 500 037
Tel. : 040 - 23721111
Fax : 040 - 23729999

KARIMNAGAR

- * **Kun Automobiles (P) Ltd.**
Showroom & Workshop :
M.No.8-6-128, Kothi Rampur, Hyderabad Highway
Road, Karim Nagar - 505 001
Tel. : 0878 - 2276633 / 9885520022
Fax : 0878 - 2276633

KHAMMAM

- * **Fusion Motors**
Showroom & Workshop :
Plot No. 11, Sri Sri Circle, Opp. Reliance Petrol Bunk,
Rotary Nagar, Bypass Road, Khammam - 507 002
Tel.: 9247623666, 8096991122

KURNOOL

- * **Dheeraj Motors**
Showroom :
Survey No. 133/1a & 131/1, NH-7,
Near Eenadu Press Office, Kurnool - 518 004
Tel. : 08518 - 253777
Fax : 08518 - 251777

Workshop :

NH-7 Road, Near APSP 2nd Battalion,
Ballary Chowrasta, Kurnool - 518 004
Tel. : 8518 - 253777

- * **NELLORE**
M.G. Brothers Automobiles (P) Limited

Showroom:
26-2-1777, Near Ayyappa Temple, Vedayapalem Area,
Nellore-524004
Tel.: 9247000000

Workshop :

Plot No. 95 & 96, Wood Complex,
Near Ayyappa Temple, Nellore - 524004
Tel. : 9247000022

* **RAJAHMUNDRY**
Orange Auto Pvt. Ltd.
Showroom & Workshop :
 D. No. 82-10-2, Venkateswara Nagar,
 Near Lalacheruvu, Near ONGC Complex, NH-5 Road,
 Rajahmundry - 533 103
 Tel. : 0883 - 6575555 / 6580888

* **TIRUPATHI**
M.G. Brothers Automobiles (P) Limited
Showroom:
 11-46/A, Renigunta Road, Tirupathi - 517501
 Tel.: 9299999970

Workshop :
 Plot No: 254, Auto Nagar,
 Near Vinayaka Temple, Renigunta Road,
 Tirupathi - 517506
 Tel.: 9247000024

* **VISHAKHAPATNAM**
Orange Auto Pvt. Ltd.
Showroom & Workshop :
 D. No.38-22-87, Varun Avenue, NH-5, Murali Nagar,
 NH. Birla Junction, Vishakhapatnam - 530 075
 Tel.: 0891 - 2572222, 9052402345

Showroom 2 :
 D. No. 4-46-12, G. K. Mansiomp, Pedawaltier,
 Vishakhapatnam - 530 017
 Tel.: 0891 - 2572222, 4444
 Fax: 0891 - 6645555

* **VIJAYWADA**
Fusion Motors
Showroom :
 Fusion Towers, 36-12-2, Opposite to Siddhartha
 Public School, Moghul Rajapuram,
 Vijayawada - 520 010
 Tel. : 0866 - 6645555 / 9603123666
 Fax : 0866 - 6645592

Workshop :
 Opposite to Fusion Towers, 36-12-2,
 Near Siddhartha Public School, Moghul Rajapuram,
 Vijayawada - 520 010
 Tel. : 0866 - 6645593 / 94, 9603123777

* **WARANGAL**
Kun Automobiles (P) Ltd.
Showroom :
 Door No. 15-2-4-1-1 & 15-2-4,
 Mulugu Cross, Warangal - 506 007
 Tel. : 0870 - 2421955
 Fax : 0870 - 2421955

Workshop :
 H. No. 23-6-132, Hunter Road,
 Opp. Citizens Club, Warangal
 Tel. : 0870 - 2523377 / 88 / 99
 Fax : 0870 - 2523399

STATE - KARNATAKA

* **BANGALORE**
Kropex India Ltd.
Showroom & Workshop :
 49/1, Singasandara, Hosur Main Road,
 Bangalore - 560 068
 Tel. : 080 - 43574357
 Fax : 080 - 43574353

Showroom 2 :
 #7/1, Binnamangala, 100 Feet Road, 1st Stage,
 Indira Nagar, Bangalore, Karnataka - 560 038
 Tel. : 080 - 42019013
 Fax : 080 - 42019216

Workshop 2 :
 Sy. No. 26, Hanumareddy Layout,
 Chinnapanahalli Main Road, Marathahalli Post,
 Bangalore - 560037
 Tel. : 9663388812

* **Trident Automobiles Pvt. Ltd.**
Showroom & Workshop :
 SY. No. 18/1B, (Old No 18/1C), Nayanda Halli Grama,
 Kengeri Hobli, Bangalore - 560038
 Tel. :080 - 67149191/292, 67149001

Showroom & Workshop 2 :
 No. 122/1, C. Shankar Reddy Layout, Kalyana Nagar,
 Outer Ring Road, Bangalore - 560 043
 Tel. : 080 - 43430300, 43430500
 Fax : 080 - 43430308, 43430517

Showroom 3 :
 14, Langford Avenue, Langford Road,
 Bangalore - 560 025
 Tel. : 080 - 4330300

Showroom 4 :
 No. 300 A - 70, 36th Cross, 10th Main,
 5th Block, Jay Nagar, Bangalore - 560 041
 Tel. : 080 - 42542999

Showroom 5 :
 #95/3, Doddanekundi Village, Karthik Nagar,
 Marathahalli, Bangalore - 560037
 Tel. : 080-30651404

Workshop 3 :
 No. 558/1,60 ft Road, 9th Cross, HAL 2nd Stage,
 Old Airport Road, Behind Leela Palace,
 Kodihalli, Indiranagar, Bangalore - 560008
 Tel. : 080 - 49155858

* **K.H.T. Chevrolet (A Division Of Morzaria Real
 Tech Private Limited)**
Showroom :
 No: 725, West of Cord Road, Rajajinagar,
 1st Stage, Mahalakshmi Layout, Bangalore - 560 086
 Tel. : 080 - 49363636

Workshop :
 No. 305, 5th Main Road, 2nd Cross, 4th Phase,
 Peenya Industrial Area, Bangalore - 560 058
 Tel. : 080 - 49353637

* **BELGAUM**
Bellad Enterprises Pvt. Ltd.
Showroom & Workshop :
 Shri Krishna Weaving Mill Compound,
 Vengualar Road, Vijaya Nagar, Belgaum - 591 108
 Tel. : 0831 - 2449556 / 557, 6514911
 Fax : 0831 - 2472209

* **BELLARY**
Bellad Enterprises Pvt. Ltd.
Showroom & Workshop :
 Near Bellary Rolling Mills, Anantpur Road,
 Bellary - 583 101
 Tel. : 08392 - 261234 / 5
 Fax : 08392 - 261235

188 Service Network

- DAVANGERE**
★ **Modi Motors**
Showroom & Workshop :
#869/1-2, PB Road, Opposite Sai International Hotel,
Davangere - 577006
Tel. : 08192 - 233896
- GULBARGA**
★ **VKG Motor World**
Showroom & Workshop :
Plot - 1&2, Survey No. 116/2, Behind Mahendrakar
Complex, Kapnoor Humnabad Road, Gulbarga - 585104
Tel. : 08472 - 224555
Fax : 08472 - 258019
- HUBLI**
★ **Bellad Enterprises Pvt. Ltd.**
Showroom & Workshop :
Opp. NGEF, Rayapura, Dharwad,
P. B. Road, Hubli-580025
Tel. : 0836 - 2218338 / 39
Telefax : 0836 - 2218337
- MANGALORE**
★ **Frontline Automobiles**
Showroom & Workshop :
NH-17, Kullur, Mangalore - 575 013
Tel. : 0824 - 2453091, 2453162, 2453092
Telefax : 0824 - 2459391
- MYSORE**
★ **Dyuthi Motors Pvt. Ltd.**
Showroom & Workshop :
No. 201 / 1 & 2, Hunsur Road, Hinkal Village,
Mysore - 570017
Tel. : 0821 - 4240500 - 16
Fax : 0821 - 4241899
- SHIMOGA**
★ **Frontline Automobiles**
Showroom & Workshop :
Shankar Muth Road, Shimoga - 577 201
Tel. : 08182 - 229099
Fax : 08182 - 229098

- UDUPI**
★ **Frontline Automobiles**
Showroom :
Shekinah Manor, D. No. 10-47-A1,
Near Laxmi Venkatesh Temple, NH-17,
Ambagilu, Puttur, Santhekatte Post, Udupi - 576 105
Tel. : 0820 - 2581999
Fax : 0820 - 2583801
- Workshop :**
NH-17, Behind IOCL Fuel Station,
Katapady, Udupi - 574 105

STATE - KERALA

- ★ **ALLEPPEY**
Geeyam Motors Pvt. Ltd.
Showroom :
Koorayil Annex, Opp. Bhathathiripurayidom,
Near MCH Junction, Alappuzha, Alleppey - 688 001
Tel. : 0477 - 2238501
- ★ **CALICUT**
German Motors
Showroom & Workshop :
118-A, Chungam Junction, West Hill, Calicut - 673005
Tel. : 0495 - 2383680 / 81, 2383770 / 71
Fax : 0495 - 3041100, 2381909
- ★ **COCHIN**
Geeyem Motors Pvt. Ltd.
Showroom & Workshop :
11/336, NH-47 Bye Pass, Nettor P.O.,
Ernakulam, Cochin - 682 304
Tel. : 0484 - 2703245 - 49, 3097100, 3097101
Fax : 0484 - 2703244
- Showroom 2 :**
33/2440B, Geetanjali Junction, NH Bypass
Chakkaraarambu, Cochin - 682 032
Tel. : 0484 - 2343146
- ★ **CHALAKKUDY**
Geeyem Motors Pvt. Ltd.
Showroom :
IX/461A, B, Panampilly College, NH-47, Potta,
Chalakkudy - 680722
Tel. : 0480 - 2705125, 2705123
- ★ **KANJRAPALLI**
Geeyem Motors Pvt. Ltd.
Showroom :
Near A K J M School, K K Road, Kanjirappally
(Kottayam Dt.)
Tel. : 0482 - 8201616
- ★ **KANNUR**
German Motors
Showroom & Workshop :
BP6-14A, Valapattanam, Kannur - 670 010
Tel. : 0497 - 2774466 - 67, 3057200
Fax : 0497 - 27744666, 3057200
- ★ **KASARGOD**
German Motors
Showroom & Workshop :
15/89B, Citizen Nagar, Chengala, Kasargod - 671123
Tel. : 04994 - 302200 - 10
Fax : 04994 - 302211
- ★ **KAYAKULAM**
Geeyam Motors Pvt. Ltd.
Showroom & Workshop :
NH-47, Near MSM College, Kayakulam - 690 502
Telefax : 0479 - 2446650
- ★ **KODANGULUR**
Geeyem Motors Pvt. Ltd.
Showroom :
XII/ 121-122, Opp. Medicare Hospital,
Kottapuram PO, TKS Puram, Kodungalur - 680 667
Tel. : 0480 - 2803561 / 62
- ★ **KOTAYYAM**
Geeyam Motors Pvt. Ltd.
Showroom & Workshop :
Karithas Junction, Thellakom P.O., Kotayyam-686016
Tel. : 0481 - 2792203
Fax : 0481 - 2792383
- ★ **KOLLAM**
Deedi Motors
Showroom :
Post Office Junction, Pallimukku, Kollam - 691 010
Tel. : 0474 - 3257777 / 2725959
Fax : 0474 - 2725900
- Workshop :**
Cantonment, North Nagar, Pullikada, Kollam - 691001
Tel. : 0474 - 2750010 / 11

KOTTAKKAL

- * **German Motors**
Showroom & Workshop :
260A, Palathara, Cherusola P.O., Kottakkal,
Malappuram
Tel. : 0494 - 2611666

MUVATTUPUZHA

- * **Geeyam Motors Pvt. Ltd.**
Showroom :
Mackar Plaza, EEC Market Road, PNB Junction,
Muvattupuzha - 686 673
Tel. : 0485 - 606600, 2835272 / 73
Fax : 0485 - 2832554

Workshop :

902/903, Opp. Mackar Plaza, EEC Market Road,
PNB Junction, Muvattupuzha - 686 673
Tel. : 0485 - 2835272 / 73
Fax : 0485 - 2832554

MUTTUM

- * **Geeyem Motors**
Showroom & Workshop :
SY NO: 70/15, 71/10, Thai Kkattukara P.O, N H Road,
Distt. Aluva, Muttum, Cochin - 683106
Tel. : 0484 - 2632193 / 94 / 95 / 96 / 97

PERINTHALMANNA

- * **German Motors**
Showroom & Workshop :
AP-IV 664E, Opp. ITC, Tirurkad,
Perinthalmanna - 679 531
Tel. : 04933 - 325060, 237000, 239878
Telefax : 04933 - 2737000

PALAKKAD

- * **Geeyam Motors**
Showroom & Workshop :
Door No. 8/1198, NH Bypass Road,
Chandra Nagar, Palakkad - 678 007
Tel. : 0491 - 2504133
Fax : 0491 - 2504143

PATHANAMTHITTA

- * **Deedi Motors Pvt. Ltd.**
Showroom & Workshop :
Kumbazethu Buildings, Churulicode P.O.,
Kozhencherry Road, Pathanamthitta - 689 645
Tel. : 0468 - 2272079, 2272080
Fax : 0468 - 2272078

THIRUVALLA

- * **Deedi Motors Pvt. Ltd.**
Showroom :
No. 54/2, Kurusumootil Buildings,
M C Road, Mazhuvangad, Thiruvalla - 689 101
Tel. : 0469 - 2740800

THRISSUR

- * **Geeyem Motors Pvt. Ltd.**
Showroom :
14/3-A1, Guruvayoor Road Puzhakkal,
Ayyanthole P.O., Thrissur - 680 003
Tel. : 0487 - 2388945 - 46, 2388851 - 52
Fax : 0487 - 2388851

Workshop :

Near Boating Station, Puzhakkal Post Office,
Thrissur - 680553
Tel. : 0487 - 2225100, 2225101

TRIVENDRUM

- * **Deedi Motors Pvt. Ltd.**
Showroom / Workshop :
Erumalathopu, N.H. Bye Pass Road, Venpalvattom,
Anayara P.O., Trivendrum - 695 029
Tel. : 0471 - 2556006, 3257777, 2558599, 2558499
Fax : 0471 - 2551020

WAYNAD

- * **German Motors**
Showroom / Workshop :
Muttill - Post, North Kalpetta, Waynad - 673 122
Tel. : 04936 - 304200 / 202414
Fax : 04936 - 304201

STATE - PONDICHERRY

PONDICHERRY

- * **Aakash Auto Pvt. Ltd.**
Showroom :
No. 1, Sounderrajan, 100 ft. Road, Sounder Rajan
Nagar, Mudaliarpet, Pondicherry - 605 004
Tel. : 0413 - 2204400
Fax : 0413 - 2204033

Workshop :

No. 23, 9th Cross, Metupallyam,
Industrial Estate, Pondicherry - 605 009
Tel. : 0413 - 2279900

STATE - TAMIL NADU

CHENNAI

- * **Sundaram Motors**
Showroom & Workshop :
180, Anna salai Road, Chennai - 600 006
Tel. : 044 - 28579203 / 28 / 32
Fax : 044 - 28579210

Workshop 2 :

116/4 Mahalakshmi Nagar Extention,
Numbal Village Thirverkadu Post, Chennai - 600077
Tel. : 044 - 26493020/21

- * **KLN Motors Agencies Pvt. Ltd.**

Showroom 1 :

Old No. 861, New No. 232, Poonamallee High Road,
Kilpauk, Chennai - 600 010
Tel. : 044 - 23452937 / 38
Telefax : 044 - 23452936

Workshop 1 :

Shop No. 50, SIDCO Industrial Area,
Ambattur, Chennai - 600 058
Tel. : 044 - 23452930 - 32

Showroom & Workshop 2 :

No. 8-NP, Developed Plot, Guindy Industrial Estate,
Ekkattuthangal, Near Kasi Theatre, Chennai - 600097
Tel. : 044 - 23458941 / 42

CUDDALORE

- * **Aakash Auto Pvt. Ltd.**
Showroom & Workshop :
RS No.155/11, Vadalur Main Road, Periamedu,
Karaikadu Village, Cuddalore Taluk,
Cuddalore - 607005
Tel. : 04142-297997, 7373299933, 7373599933

COIMBATORE

- * **Anamallais Agencies (P) Ltd.**
Showroom :
252, Mettupalayam Road, Coimbatore - 641 043
Tel. : 0422 - 2435555 / 2432999
Fax : 0422 - 2446151

Workshop :

249A, Mettupalayam Bye Pass Road,
Coimbatore - 641043
Tel. : 0422 - 2433444

190 Service Network

★ **Pressana Automobile**

Showroom :

No. 1987, Trichy Main Road, LCT Complex,
Coimbatore - 641005
Tel. : 0422 - 4041111

Workshop :

505/1, Sowaripalayam Main Road,
Ramanathapuram, Coimbatore - 641045
Tel. : 0422 - 4051111

ERODE

★ **Pressana Automobile**

Showroom & Workshop :

No.1, ChinnaKadu Thottam,
Veerampalayam, Dhindal P.O., Erode - 638 012
Tel. : 0424 - 2276046 / 47
Fax : 0424 - 2276048

HOSUR

★ **Thriive Cars**

Showroom :

2, Rajappa Mudaliar Building,
NH-7, Krishnagiri, Bangalore Bypass Road, Hosur
Tel. : 04344 - 644588

Workshop :

2/2, 1E, Balaji Nagar, Rayakottai Road,
Opp. to LUK India, Hosur - 635109
Tel. : 04344 - 291033

KARUR

★ **Pressana Automobile**

Showroom & Workshop :

No.3, Salem Bypass Road, Kulathupalayam,
Karur - 635 006
Tel. : 04324 - 222301
Fax : 04324 - 222302

MADURAI

★ **A.R.A.S. Motors (P) Ltd.**

Showroom :

35/1, Dindigul National Highway,
Near A. R. C. Parcel Service, Villangudi,
Madurai - 625018
Tel. : 0452 - 2669617, 3091917
Fax : 0452 - 2669618

Workshop :

Plot No. 64 & 68, Thiruvalavayanallur Post,
National Highway No. 7, Opp Arokya Milk
Processing Unit, Nagari, Madurai - 625 221
Tel. : 0452 - 2463612 / 13 / 14

NAGERCOIL

★ **A.R.A.S. Motors (P) Ltd.**

Showroom & Workshop:

2/86, Tirumelveli Main road,
Ozhuginasery, Nagercoil - 629 001
Tel. : 04652 - 644664 (Showroom)
04652 - 272443 (Workshop)

NAMAKAL

★ **Thriive Cars**

Showroom :

5/58, Salem Main Road, Namakal
Tel. : 04286 - 275603

Workshop :

276/85, Tiruchengode Main Road,
Opp. Old Lakshmi Kalyana Mandapam,
Namakkak - 637 001

PUDUKOTTAI

★ **Jayaraj Karz**

Showroom & Workshop :

5915/1, Khalif Nagar, Thirumayam Road,
Pudukottai - 622 001
Tel. : 04322 - 262223

PERAMBALUR

★ **Jayaraj Karz**

Showroom & Workshop :

No. 36, Trichy to Chennai Highway, Eraiyyur,
Veppanthattai, Perambalur, Tamilnadu - 621 133
Tel. : 9244222728

SALEM

★ **Thriive Cars**

Showroom & Workshop :

1116, Salem Chennai Highway Road,
Near Holy Cross, Hr. Sec. School,
Ammamet, Salem - 636 014
Tel. : 0427 - 2242603
Fax : 0427 - 2242604

TRICHY

★ **Jayaraj Karz**

Showroom & Workshop :

Madurai Main Road, Panjapur, Trichy - 620 012
Tel. : 0431 - 2906420 / 6541207
Fax : 0431 - 2202187

THIRUNELVELLI

★ **A.R.A.S. Motors (P) Ltd.**

Showroom & Workshop :

1183/3, National Highway Jothipuram,
Konganthamparai, Thirunelveli - 627 007
Tel. : 0462 - 2551070, 3269638
Fax : 0462 - 2554111

TIRUPUR

★ **Anamallais Agencies Pvt. Ltd.**

Showroom & Workshop :

396/6, Kamaraj Road, Palladam Road,
Tirupur - 641 604
Tel. : 0421 - 2918999

THANJAVUR

★ **Jayaraj Karz**

Showroom & Workshop :

Pudukottai Bye - Pass Road, Thanjavur
Tel. : 04362 - 226452

VELLORE

★ **Sayar Cars**

Showroom & Workshop :

S.F. No. 3004, New By Pass Road,
Near Collectorate, Vellore - 632004
Tel.: 0416 - 2222017

EAST ZONE

STATE - ARUNACHHAL PRADESH

- ITANAGAR**
 * **Sango Motors**
Showroom & Workshop :
 NH-52A, Near Shiv Mandir, 6 Km
 Between Nahalagun, Dist. Papumpare
 Itanagar, Arunachal Pradesh - 791 110
 Tel. : 0360 - 2001166 / 67, 2033153

STATE - ASSAM

- BONGAIGAON**
 * **Raj N Dibyani Automobiles**
Showroom & Workshop :
 Near Lower Assam Hospital, Chapaguri Road,
 North Bongaigaon, Bongaigaon
 Tel.: 03664 - 231890, 230545
- DIBRUGARH**
 * **Pashupati Traders**
Showroom & Workshop :
 P. N. Road, Chiring Chapori, Dibrugarh - 786 001
 Tel. : 0373 - 2323281
 Telefax : 0373 - 2323296
- GUWAHATI**
 * **Srishti Automobiles Pvt. Ltd.**
Showroom :
 Opp. Pantaloons, G S Road, Rukminigaon,
 Guwahati, Assam - 781 022
 Tel. : 0361 - 2223666
 Fax : 0361 - 2223888
- Workshop :**
 Radha Nagar, VIP Road, Six mile, Guwahati,
 Assam - 781 022
- SHIBSAGAR**
 * **Pashupati Traders**
Showroom & Workshop :
 KPM Chariali, Shivasagar, Shivasagar - 785 640
 Tel. : 03772 - 220082 / 88

- SILCHAR**
 * **Smart Motors Pvt. Ltd.**
Showroom & Workshop :
 NH-54, Ramnagar, Silchar - 788 008
 Tel. : 03842 - 268701, 9207042806

- NAGAON**
 * **LB Motor (A Unit of Borah & Sons Pvt. Ltd)**
Showroom & Workshop:
 AT Road, Dimarguri, Nagaon - 782003
 Tel.: 03672- 253157

- TEZPUR**
 * **GNB Motors**
Showroom :
 P.O. Nikamul, Beside Udyanpath,
 Tezpur - 784001
 Tel. : 03712 - 255999

- Workshop :**
 P.O. Nikamul, Udyanpath,
 Tezpur - 784001
 Tel. : 03712 - 255998

- TINSUKIA**
 * **Dhansri Motors**
Showroom & Workshop :
 Opposite New Tinsukia Railway Junction,
 A.T. Road, Hijuguri, Tinsukia - 786125.
 Tel. : 0374 - 2311397

STATE - BIHAR

- MUZAFARPUR**
 * **Pandey Motors Pvt. Ltd.**
Showroom & Workshop :
 Mithila Body Builders, NH-18,
 Bhagwanpur, MuzaFarapur - 842 001
 Tel. : 0621 - 2252762

- PATNA**
 * **Pandey Motors Pvt. Ltd.**
Showroom :
 Pandey Plaza, Exhibition Road, Patna - 800 001
 Tel. : 0612 - 2205195, 3955491
 Fax : 0612 - 2205196

- Workshop :**
 Bhootnath Road, Sahadurpur, PS Agamkuan,
 Patna - 800 020
 Tel. : 0612 - 2341151

- GAYA**
 * **Brijnandan Automobile Pvt. Ltd.**
Showroom & Workshop :
 727 Old 1026 / New No. NH - 83,
 Near BMP - 3, Gaya - 823004
 Tel. : 0631 - 2200131

- PURNEA**
 * **Hare Krishna Motors Pvt. Ltd.**
Showroom & Workshop :
 Damka Chowk, NH - 31, Gulababagh, Purnea - 854326
 Tel. : 9234323211

STATE - JHARKHAND

- BOKARO**
 * **Power Motors**
Showroom & Workshop :
 N-1, City Centre, Sector - 4,
 Bokaro Steel City, Bokaro - 827004
 Tel. : 0654 2- 233555 / 232977
 Fax : 06542 - 232988

- DHANBAD**
 * **Sorabh Automobiles**
Showroom :
 Indramani Palace, Opp Flair Bajaj, Saraidhela,
 Dhanbad - 826001
 Tel. : 0326 - 2201366

- Workshop :**
 Tilakraidih, Govindpur Road, Dhanbad - 826001
 Tel. : 9470580855

- HAZARIBAGH**
 * **Laxmi Auto**
Showroom & Workshop :
 Zulu Park Road, Near SBI Main Branch,
 Hazaribagh - 825301
 Tel. : 06546 - 222929

- JAMSHEDPUR**
 * **Narberam Motors Pvt. Ltd.**
Showroom & Workshop :
 M-4, Phase-VI, Adityapur Industrial Area,
 P.O. Gamaria, Jamshepur - 832 108
 Tel. : 0657 - 3293612, 3297763, 3290649, 6510531
 Telefax : 0657 - 2200532

192 Service Network

- RANCHI**
* **Rahul Automobiles Pvt. Ltd.**
Showroom 1 :
Piska More, Ratu Road, Ranchi - 834 005
Tel. : 0651 - 2510251 / 52
- Showroom 2 :**
Line Tank Road, MR Tower, Ranchi - 834 001
Tel. : 0651 - 3298436
Fax : 0651 - 2510252
- Workshop :**
Ratu Road, Near Kamre Ashram, Ranchi - 834 005
Tel. : 0651 - 2511558 / 564, 3241206

STATE - ORISSA

- BALASORE**
* **Venus Auto Works Pvt. Ltd.**
Showroom & Workshop :
NH - 5, Remuna Golai, Janaganj,
Near Bhattar Mill, Balasore -756 019
Tel. : 06782 - 244013, 244014
- BHUBANESWAR**
* **Venus Auto Works Pvt. Ltd.**
Showroom & Workshop :
A/62, Nayapalli, Bhubaneswar - 751 003
Tel. : 0674 - 3019999 (Showroom)
0674 - 3019900, 3270444, 9337070444
(Workshop)
Telefax : 0674 - 3019908
- * **Super Sales Automobiles Pvt. Ltd.**
Showroom & Workshop :
Plot No. 644/2148, NH-5, Pahal,
Bhubneswar, Dist - khurda - 752 101
Tel. : 0674 - 2463913, 2463914, 6543010 / 11
- * **CUTTACK**
* **Super Sales Automobiles Pvt. Ltd.**
Showroom :
Rudrapur, NH - 5, Pratap Nagri, Cuttack - 753 011
Tel. : 0671 - 2686878
Fax : 0671 - 2686889

- SAMBALPUR**
* **Bharat Motors Ltd.**
Showroom & Workshop :
9, Industrial Estate, Near Central School,
Bareipali, Sambalpur - 768 006
Tel. : 0663 - 2402736, 2405286
Fax : 0663 - 2585894
- ROURKELA**
* **Balaram Motors**
Showroom & Workshop :
Opposite Pahadi Kanta, Vedyyash, Rourkela - 769 041

STATE - WEST BENGAL

- ASANSOL**
* **Shaila Autotech**
Showroom & Workshop :
NH-2, Chanda More, Asansol - 713 339
Telefax : 0341 - 2343704 / 705
- HOWRAH**
* **Priti Motor Udyog (P) Ltd.**
Showroom :
NH-6, Bombay Howrah Highway, Howrah
- Workshop :**
Khejurtala Kolkata Truck Terminal,
Khejurtala, NH-6, Howrah - 711403.
Tel. : 033 - 65002070/71/72
- KOLKATA**
* **OSL Autotech Pvt. Ltd.**
Showroom :
2/1A, Sarat Bose Road, Lansdowne Towers,
Kolkata - 700 020
Tel. : 033 - 66270400
- Workshop :**
49 E, Topsia Road South, Kolkata - 700 046
Tel. : 033 - 66270500
- * **Speed Autotech**
Showroom :
"The Meridian", Kazi Nazrul Islam Sarani,
(VIP Road), Kolkata - 700 059
Tel. : 033 - 25007915 - 9
Fax : 033 - 40150824

Workshop 1 :
241/2B, APC Road, Opp. Khanna Cinema,
Kolkata - 700 004
Tel. : 033 - 25551370 / 72 / 73 / 74, 25552509

Workshop 2 :
108 F, Nilgunge Road, Agarpara, Kolkata - 700058
Tel. : 033 - 25552509

- * **Dulichand Motors Pvt. Ltd.**
Showroom :
"Shrachi Towers", 686 Anandapur,
E.M. Bypass, Near Ruby Hospital, Kolkatta - 700 107
Tel. : 033 - 24431801 - 02, 40141616
Fax : 033 - 40141624

Workshop :
5/51, Jagatipota, Ahalya Nagar,
Opp. Jagatipota Kisan Market, Kolkatta - 700 099
Tel. : 033 - 40161718, 24264224, 24264214

- **Longia Motors Pvt. Ltd.**
Workshop 1 :
15/1D, Sahanagar Road, (Near Rashbehari Avenue
Crossing), Kolkatta - 700 026
Tel. : 033 - 66270100 / 119
Fax : 033 - 66270121

Workshop 2 :
Budge Budge Trunk Road, Rampur, P.O. : Gobindopur,
P.S. : Maheshtala, Kolkata - 700 141
Tel. : 033 - 66270222/223/205
Fax : 033 - 66270208

- SILIGURI**
* **Kaysons Automotive Pvt. Ltd.**
Showroom & Workshop :
11/rd Mile, Checkpost,
Opp. New Eastern Bypass Road,
Sevoke Road, Siliguri - 734 401
Tel. : 0353 - 2544533 - 35, 2777723
Fax : 0353 - 2544456

STATE - MANIPUR

- IMPHAL**
* **Rajpri Enterprise**
Showroom & Workshop :
Chigmeirong Mamang Leikai,
Imphal East, Imphal - 795 001
Tel. : 0385 - 2421183

STATE - TRIPURA

DIMAPUR

★ **Urban Station**

Showroom & Workshop :

NSC Petrol Pump, NH-39, 6th Mile, Kohima Road,
Dimapur, Nagaland - 797 112
Tel. : 03862 - 240994, 240992

STATE - MEGHALAYA

AGARTALA

★ **Sri Krishna Automobiles**

Showroom & Workshop :

Plot No. 4612 & 4615, Shanihani,
Airport Road, Agartala, Tripura West - 799 001
Tel. : 0381 - 2342566

STATE - SIKKIM

SHILLONG

★ **DH Royal Cars**

Showroom & Workshop :

Parkview, Fire Brigade,
Shillong - 793 014
Tel. : 0364 - 2520481, 2520477

STATE - MIZORAM

GANGTOK

★ **GEN X Motors**

Showroom :

5th Mile, Jhordhara, Tadong, Gangtok - 737 102
Tel. : 03592 - 202515
Fax : 03592 - 203171

Workshop :

C/o Garima Enterprise, P.S. Road, Gangtok - 737 101
Tel. : 03592 - 202515

STATE - NAGALAND

AIZAWL

★ **Highland**

Showroom & Workshop :

A-L Road, Zemabawk, Aizawl - 796017
Tel. : 0389 - 2351916

INTERNATIONAL

- ★ **SRI LANKA**
Mag City Motor Company Pvt. Ltd.
Showroom & Workshop :
No. 320A, Darley Road,
Colombo - 10, Sri Lanka
Tel. : 0094777410407

- ★ **BHUTAN**
Global Trade
Showroom :
Lkahlham, Changgankha,
Thimphu, Bhutan

Workshop :
Post Box No. 1037, Olarongcchu,
Thimphu, Bhutann

- **NEPAL**
SPG Automobiles Pvt. Ltd.
Workshop :
GPO Box 2544, Khumaltar, Lalitpur,
Kathmandu, Nepal
Tel.: 00977-1-4100543



General Motors India Pvt. Ltd.

All information, illustrations and specifications contained in this Owner's Manual are based on the latest production information available at the time of publication. The right is reserved to make changes at any time without notice.

Regd. Office : Chandrapura Industrial Estate, Halol - 389 351

Dist. Panchmahals, Gujarat, India. Phone : 91 2676 221000

Customer Assistance Center : Plot No. 15, Echelon Institutional Area,

Sector 32, Gurgaon - 122 001, Haryana, India. Tel.: 91 124 3080000

Works : A-16, MIDC Talegaon Industrial Area (Phase-II),

Near Floriculture Park, Talegaon Navlakh Umbhre Village Road, Tehsil-Maval,

Pune - 410 507, Maharashtra, India. Tel: 91 2114 663939

24 Hr. Helpline at 1800 3000 8080

Part No.: 28286179

Revision No. 03

Revision Date

04/2014/1,020