

2015 Chevrolet Spark Owner Manual

In Brief	1-1	Instruments and Controls	5-1	Driving and Operating	9-1
Initial Drive Information	1-1	Controls	5-2	Driving Information	9-1
Keys, Doors, and		Warning Lights, Gauges, and		Starting and Operating	9-2
Windows	2-1	Indicators	5-10	Engine Exhaust	9-4
Keys and Locks	2-1	Trip Computer	5-20	Automatic Transmission	9-4
Doors	2-6	Vehicle Personalisation	5-23	Manual Gearbox	9-9
Vehicle Security	2-7	Lighting	6-1	Brakes	9-10
Exterior Mirrors	2-10	Exterior Lighting	6-1	Ride Control Systems	9-13
Interior Mirrors	2-12	Interior Lighting	6-5	Object Detection Systems	9-14
Windows	2-13	Lighting Features	6-5	Fuel	9-16
Seats and Restraints	3-1	Infotainment System	7-1	Vehicle Care	10-1
Head Restraints	3-1	Introduction	7-1	General Information	10-2
Front Seats	3-3	Radio	7-11	Vehicle Checks	10-3
Safety Belts	3-6	Audio Players	7-23	Bulb Replacement	10-19
Airbag System	3-11	Personalisation	7-40	Electrical System	10-24
Child Restraints	3-17	Phone	7-44	Vehicle Tools	10-30
Storage	4-1	Climate Controls	8-1	Wheels and Tyres	10-30
Storage Compartments	4-1	Climate Control Systems	8-1	Jump Starting	10-48
Luggage/Load Locations	4-4	Air Vents	8-9	Towing the Vehicle	10-49
Additional Storage Features ...	4-6	Maintenance	8-10	Appearance Care	10-53
Roof Rack System	4-7				
Information on Loading the					
Vehicle	4-7				

2015 Chevrolet Spark Owner Manual

Service and Maintenance . . .	11-1
General Information	11-1
Maintenance Schedule	11-2
Additional Maintenance and Care	11-7
Recommended Fluids, Lubricants, and Parts	11-7
Technical Data	12-1
Vehicle Identification	12-1
Vehicle Data	12-3
Customer Information	13-1
Customer Information	13-1
Vehicle Data Recording and Privacy	13-2
Index	i-1

Your vehicle is a combination of design, advanced technology, safety, environmental friendliness and economy.

This Owner's Manual provides you with all the necessary information to enable you to drive your vehicle safely and efficiently.

Make sure your passengers are aware of the possible risk of accident and injury which may result from improper use of the vehicle.

You must always comply with the specific laws and regulations of the country that you are in. These laws may differ from the information in this

When this Owner's Manual refers to a repairer visit, we recommend your Chevrolet Service Partner.

All Chevrolet Service Partners provide first-class service at reasonable prices. Experienced mechanics trained by Chevrolet work according to specific Chevrolet instructions.

The customer literature pack should always be kept ready to hand in the vehicle.

Using this Manual

- This manual describes all options and features available for this model. Certain descriptions, including those for display and menu functions, may not apply to your vehicle due to model variant, country specifications, special equipment or accessories.
- The "In brief" section will give you an initial overview.
- The table of contents at the beginning of this manual and within each chapter shows where the information is located.
- The index will enable you to search for specific information.

- The Owner's Manual uses the factory engine designations. The corresponding sales designations can be found in the chapter "Technical data".
- Directional data, e.g. left or right, or front or back, always relate to the direction of travel.
- The vehicle display screens may not support your specific language.

Danger, Warnings, and Cautions



Text marked  **Danger** provides information on risk of fatal injury. Disregarding this information may endanger life.

iv Introduction

Warning

Text marked  Warning provides information on risk of accident or injury. Disregarding this information may lead to injury.

Caution

Text marked Caution provides information on possible damage to the vehicle. Disregarding this information may lead to vehicle damage.

We wish you many hours of
pleasurable driving

Chevrolet

In Brief

Initial Drive Information

Unlocking the Vehicle	1-1
Seat Adjustment	1-1
Head Restraint Adjustment	1-3
Safety Belts	1-3
Mirror Adjustment	1-4
Steering Wheel Adjustment ...	1-5
Instrument Panel Overview	1-6
Exterior Lighting	1-11
Horn	1-12
Washer and Wiper	
Systems	1-13
Climate Controls	1-14
Parking	1-15
Transmission	1-15
Getting Started	1-16

Initial Drive Information

Unlocking the Vehicle

Radio remote control



Press button .

Unlocks all doors. The hazard warning lights will flash twice.

Radio remote control ⇨ *Radio Remote Control on page 2-2,*

Central locking system ⇨ *Central Locking System on page 2-4.*

Seat Adjustment

Seat positioning



1-2 In Brief

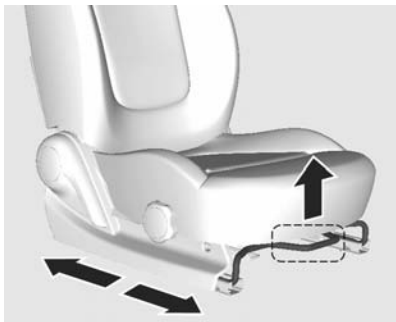

Pull handle, slide seat, release handle.

Seat position ⇨ *Seat Position on page 3-3*, Seat adjustment ⇨ *Seat Adjustment on page 3-4*.

Seat backrests



Pull lever, adjust inclination and release lever. Allow the seat to engage audibly.

Seat position ⇨ *Seat Position on page 3-3*, Seat adjustment ⇨ *Seat Adjustment on page 3-4*.

Seat height

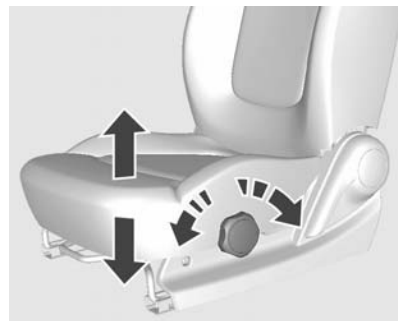



Turn the handwheel on the outside of the seat cushion until the seat cushion is adjusted to the desired position.

Seat position ⇨ *Seat Position on page 3-3*, Seat adjustment ⇨ *Seat Adjustment on page 3-4*.

Head Restraint Adjustment

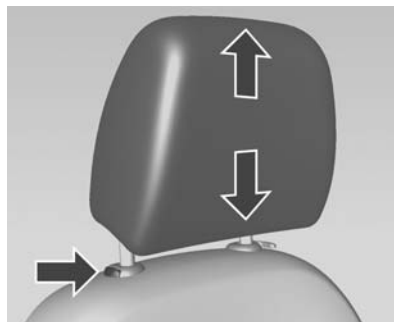

Pull the head restraint upwards.

To move down press the catch and push the head restraint downwards.

Head restraints ⇨ *Head Restraints on page 3-1*.

Safety Belts



1-4 In Brief

Withdraw belt from reel, guide it untwisted across the body and engage the latch plate in the buckle.

Tension the lap belt regularly whilst driving by tugging the shoulder belt.

Seat position ⇨ *Seat Position on page 3-3*, Seat belts ⇨ *Three-Point Seat belt on page 3-8*, Airbag system ⇨ *Front Airbag System on page 3-12*.

Mirror Adjustment

Interior Mirror

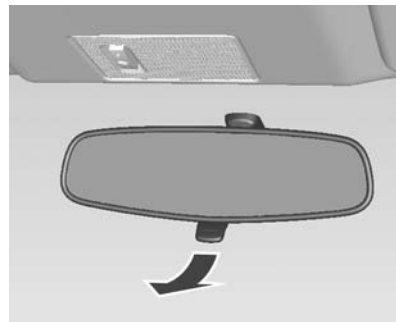
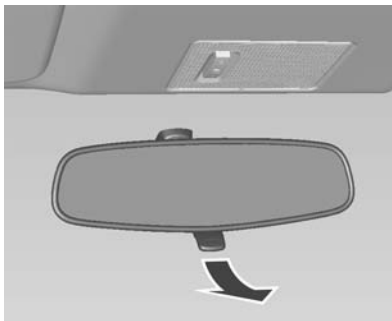

To reduce dazzle, pull the lever on the underside of the mirror housing.

Interior mirror ⇨ *Manual Rearview Mirror on page 2-12*.

Exterior Mirrors



Simply move the adjusting lever in the desired direction to adjust the mirror angles.

Convex exterior mirrors ⇨ *Convex Mirrors on page 2-10*, Folding exterior mirrors ⇨ *Folding Mirrors on page 2-11*, Heated exterior mirrors ⇨ *Heated Mirrors on page 2-12*.

Steering Wheel Adjustment

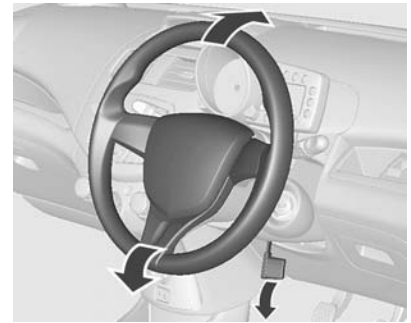
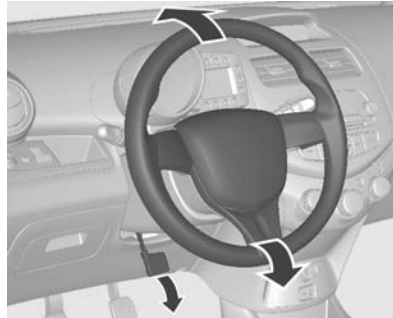

Unlock lever, adjust steering wheel, then engage lever and ensure it is fully locked. Do not adjust steering wheel unless vehicle is stationary.

Airbag system ⇨ *Airbag System on page 3-11*, Ignition positions ⇨ *New Vehicle Break-In on page 9-2*.

Instrument Panel Overview

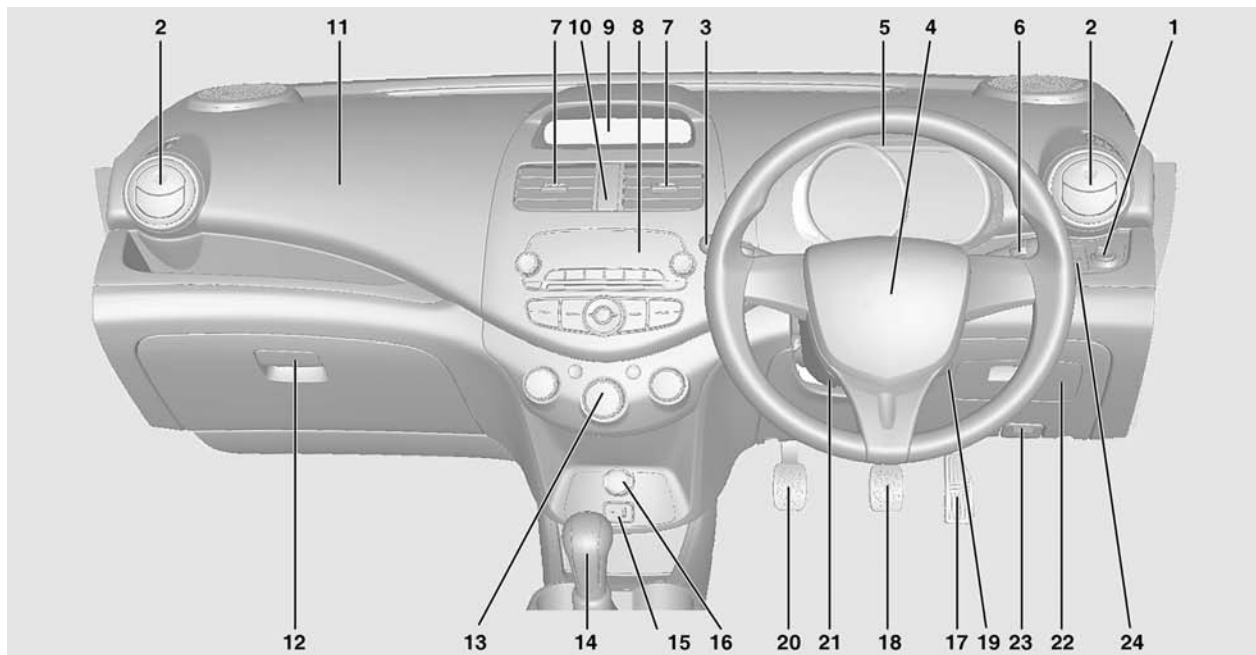

1. Electric mirror adjustment.
2. Side air vents.
3. Exterior lighting.
4. Horn.
Driver airbag.
5. Instrument cluster.
6. Wiper and washer system.
7. Centre air vents.
8. Infotainment system.
9. Control indicators.
10. Hazard lights.
11. Front passenger airbag.
12. Glovebox.
13. Climate control system.
14. Gear lever.
15. AUX input, USB input.
16. Power socket.
17. Accelerator pedal.
18. Brake pedal.
19. Ignition switch.
20. Clutch pedal.
21. Steering wheel adjustment.
22. Fuse cover.
23. Bonnet release lever.
24. Headlight range adjustment.

1-8 In Brief

Type 1

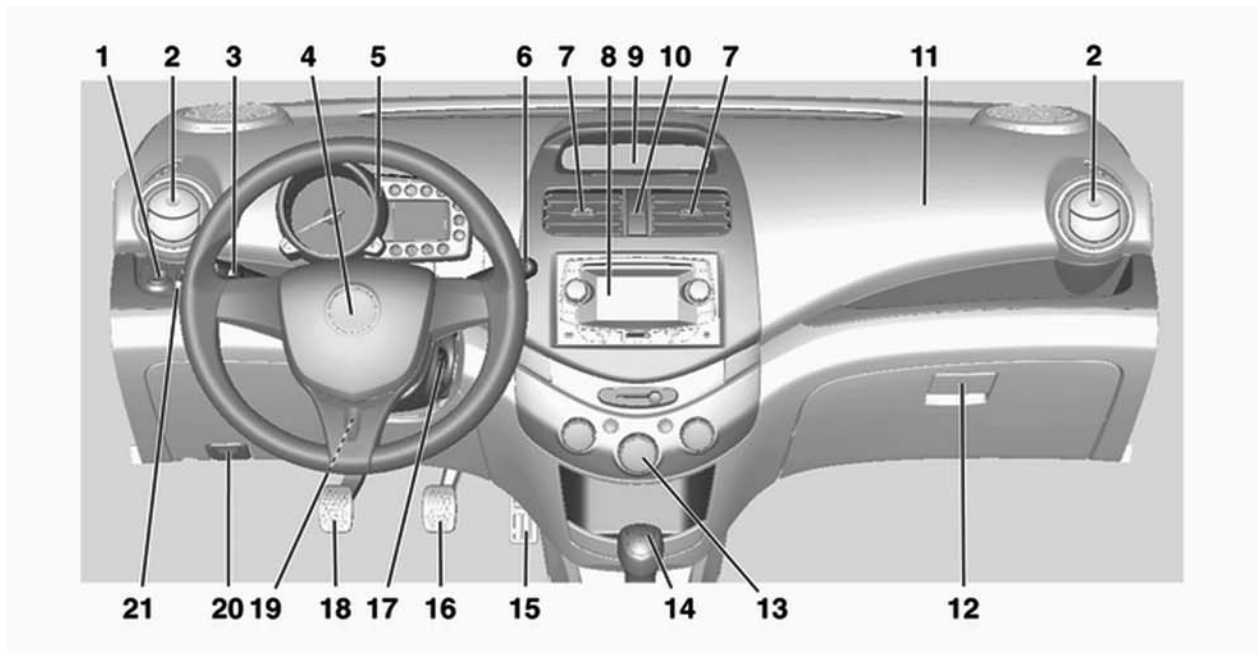

1. Electric mirror adjustment.
2. Side air vents.
3. Exterior lighting.
4. Horn.
Driver airbag.
5. Instrument cluster.
6. Wiper and washer system.
7. Centre air vents.
8. Infotainment system.
9. Control indicators.
10. Hazard lights.
11. Front passenger airbag.
12. Glovebox.
13. Climate control system.
14. Gear lever.
15. Accelerator pedal.
16. Brake pedal.
17. Ignition switch.
18. Clutch pedal.
19. Steering wheel adjustment.
20. Bonnet release lever.
21. Headlight range adjustment.

1-10 In Brief

Type 2

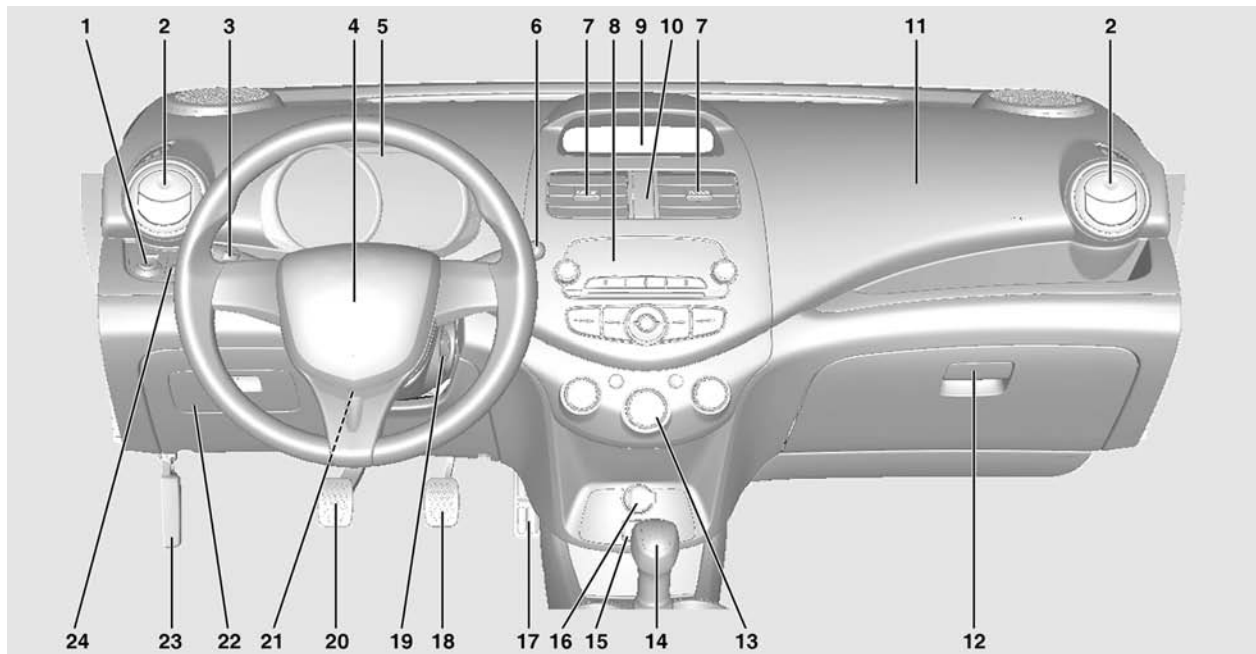

1. Electric mirror adjustment.
2. Side air vents.
3. Exterior lighting.
4. Horn.
Driver airbag.
5. Instrument cluster.
6. Wiper and washer system.
7. Centre air vents.
8. Infotainment system.
9. Control indicators.
10. Hazard lights.
11. Front passenger airbag.
12. Glovebox.
13. Climate control system.
14. Gear lever.
15. Accelerator pedal.
16. Brake pedal.
17. Ignition switch.
18. Clutch pedal.
19. Steering wheel adjustment.

20. Bonnet release lever.
21. Headlight range adjustment.
22. Fuse cover.
23. AUX input, USB input.
24. Power socket.

Exterior Lighting



Turn light switch.

OFF: All the lights are off.

 : The tail lights, number plate lights, and instrument panel lights are illuminated.

 : The dipped beam headlights and all of the above lights are illuminated.

Headlight flash, main beam and dipped beam

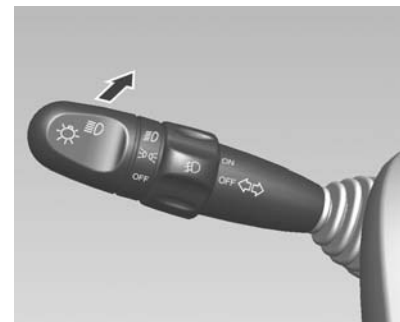

To switch from dipped to main beam, push lever.

To switch to dipped beam, push lever again or pull.

1-12 In Brief

Main beam ⇨ *Headlamp Main/Dipped Beam Changer* on page 6-1,
Headlight flash ⇨ *Flash-to-Pass* on page 6-2.

Hazard lights

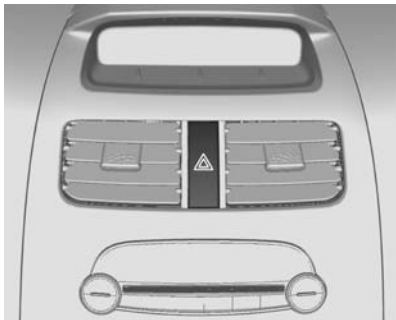

Operated with the  button.

Hazard warning lights ⇨ *Hazard Warning Flashers* on page 6-3.

Turn and lane-change signals

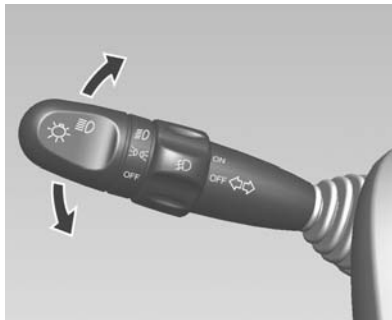

lever up = right

lever down = left

Turn and lane-change signals ⇨ *Indicator and Lane-Change Signals* on page 6-4.

Horn

Heated rear window, heated exterior mirrors





Press .

Washer and Wiper Systems

Windscreen wiper

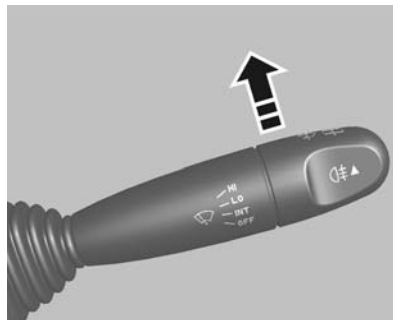

OFF: System off.

INT: Intermittent operation.

LO: Continuous wipe, slow speed.

HI: Continuous wipe, fast speed.

For a single wipe when the windscreen wiper is off, lightly move the lever toward the INT position and release it.

Windscreen wiper ⇨ *Windscreen Wiper/Washer on page 5-3.*

Windscreen washer system



Pull lever.

Windscreen washer ⇨ *Windscreen Wiper/Washer on page 5-3, Washer fluid ⇨ Washer Fluid on page 10-15.*

Climate Controls

Heated rear window, heated exterior mirrors



Type 1



Type 2

Heating is operated by pressing the  button.

Heated mirrors ⇨ *Heated Mirrors* on page 2-12, Heated rear window ⇨ *Heated Rear Window* on page 2-16.

Demisting and defrosting the windows



Type 1

**Type 2**

Turn knob to .

Defrosting windscreen ⇨ *Heating and Ventilation System on page 8-1*,
Demisting windscreen ⇨ *Air Conditioning System on page 8-5*.

Parking

- Do not park the vehicle on an easily flammable surface. The high temperature of the exhaust system could ignite the surface.

- Always apply parking brake without pressing release button. Apply as firmly as possible on downhill or uphill slopes. Depress the brake pedal at the same time to reduce operating force.
- Switch off the engine and ignition. Turn the steering wheel until the steering wheel lock engages.
- If the vehicle is on a level surface or uphill slope, engage first gear or P position before switching off the ignition. On an uphill slope, turn the front wheels away from the kerb.
- If the vehicle is on a downhill slope, engage reverse gear before switching off the ignition. Turn the front wheels towards the kerb.
- Close windows.
- Lock the vehicle and activate the anti-theft alarm system.

Keys ⇨ *Keys on page 2-1*

Transmission

Manual gearbox

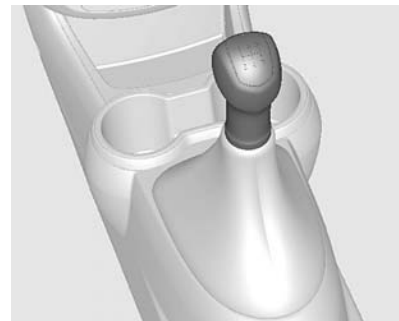

Reverse: with the vehicle stationary, depress the clutch pedal and engage the gear.

If the gear does not engage, set the lever in neutral, release the clutch pedal and depress again; then repeat gear selection.

Manual gearbox ⇨ *Manual Gearbox on page 9-9*.

Automatic transmission

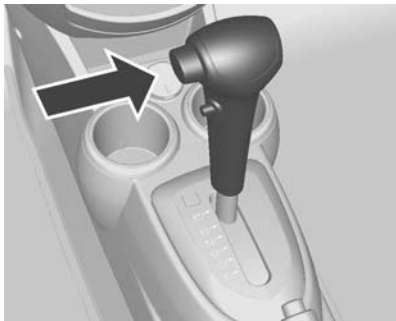

P (PARK): Locks the front wheels. Select P only when the vehicle is stationary and the parking brake is applied.

R (REVERSE): Select R only when the vehicle is stationary.

N (NEUTRAL): Neutral gear position.

D: This drive position is for all normal driving conditions. It allows the transmission to shift into all four forward gears. Fourth gear is

overdrive which reduces engine speed and noise level while increasing fuel economy.

2: Allows the transmission to shift from 1st to 2nd gear and prevents automatic shifting into 3rd or 4th gear.

1: This position locks the transmission in first gear.

Automatic transmission ⇨
Automatic Transmission on page 9-4.

Getting Started

Check before starting off

- Tyre pressure and condition.
- Engine oil level and fluid levels.
- All windows, mirrors, exterior lighting and number plates are free from dirt, snow and ice and are operational.
- Proper position of seats, seat belts and mirrors.

- Check brake function at low speed, particularly if the brakes are wet.

Starting the engine

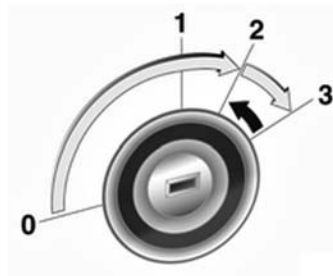

- Turn the key to position 1, move the steering wheel slightly to release the steering wheel lock
- Manual gearbox: operate clutch
- Automatic transmission : Move gear lever to P or N
- Do not accelerate

- Turn the key to position 3, depressing the clutch pedal and footbrake then release when engine is running

Before restarting or to switch off the engine, turn key back to 0.

Keys, Doors, and Windows

Keys and Locks

- Keys 2-1
- Radio Remote Control 2-2
- Central Locking System 2-4

Doors

- Load Compartment 2-6

Vehicle Security

- Anti-theft Alarm System 2-7
- Immobiliser 2-9

Exterior Mirrors

- Convex Mirrors 2-10
- Manual Mirrors 2-10
- Power Mirrors 2-11
- Folding Mirrors 2-11
- Heated Mirrors 2-12

Interior Mirrors

- Manual Rearview Mirror 2-12

Windows

- Manual Windows 2-13
- Power Windows 2-14
- Heated Rear Window 2-16
- Sun Visors 2-17

Keys and Locks

Keys

Replacement keys

The key number is specified on a detachable tag.

The key number must be quoted when ordering replacement keys as it is a component of the immobiliser system.

Locks ⇨ *Exterior Care on page 10-53.*



Key with foldaway key section

Press button to extend.

To fold the key, press the button and fold the key manually.

Radio Remote Control



Used to operate:

- Central locking system
- Anti-theft alarm system
- Vehicle alarm system

The radio remote control has an approximate range of up to 20 metres (66 ft). This range can be affected by external influences.

The hazard lights confirm operation.

Handle with care, protect from moisture and high temperatures and avoid unnecessary operation.

Fault

If the central locking system cannot be operated with the radio remote control, it may be due to the following:

- Range exceeded,
- Battery voltage too low,
- Frequent, repeated operation of the remote control while not in range, which will require resynchronisation,
- Overload of the central locking system by operating at frequent intervals, the power supply is interrupted for a short time,
- Interference from higher-power radio waves from other sources.

Radio remote control battery replacement

Replace the battery as soon as the range is noticeably diminished.



Batteries do not belong in household waste. They must be disposed of at an appropriate recycling collection point.

Key with foldaway key section



Note: Use CR2032 (or equivalent) replacement battery.

1. Open the transmitter cover.
2. Remove the used battery. Avoid touching the circuit board to other components.
3. Install the new battery. Be sure the negative side (-) faces down toward the base.
4. Close the transmitter cover.
5. Check the operation of the transmitter with your vehicle.

Fixed key

 **Caution**

Avoid touching the flat surfaces of the battery with your bare fingers. Handling will shorten battery life.

Note: Used lithium batteries can harm the environment.

Follow local recycling laws for disposal.

Do not discard with household waste.

Note: In order to keep the transmitter working properly, follow these guidelines:

Avoid dropping the transmitter.

Do not place heavy objects on the transmitter.

Keep the transmitter away from water and direct sunlight. If the transmitter gets wet, wipe it with a soft cloth.

2-4 Keys, Doors, and Windows

Central Locking System

You can activate the central door locking system from the driver's door. This system allows you to lock and unlock all the doors from the driver's door, using either the key or keyless remote (from outside) or the door lock button (from inside).

If the driver's door is not closed properly, the central locking system will not work.

Central locking button



Locks or unlocks all doors and the tailgate.

Press button  to lock.

Press button  to unlock.

If the driver's door is opened, driver's door cannot be locked.

Unlocking



Press button .

Unlocks all doors. The hazard warning lights will flash twice.

Locking





Press button .

Locks all doors. Hazard warning lights will flash once.

Vehicle alarm



- **Vehicle Locator:**
Press and release button  once to locate the vehicle. The indicator lamps flash until any button of the key is pressed.
- **Panic Alarm:**
Press and release button  once to operate Panic alarm. The horn sounds and the indicator lamps flash until any button of the key is pressed.

Fault in radio remote control system

Unlocking

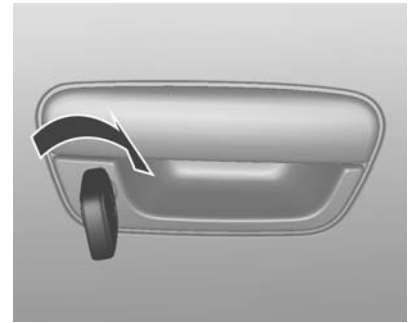
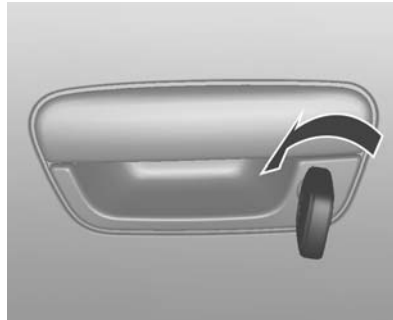

Manually unlock the driver's door by turning the key in the lock.

Locking

Close the driver's door and lock it from the outside with the key.

Fault in central locking system

Unlocking

Manually unlock the driver's door by turning the key in the lock. The other doors can be opened by using the interior handle.

2-6 Keys, Doors, and Windows

Locking

Push inside locking knob of all doors except driver's door. Then close the driver's door and lock it from the outside with the key.

Child locks

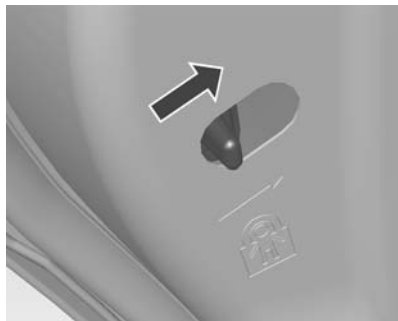

Caution

Do not pull the inside door handle while the child security door lock is set to LOCK position. To do so can damage the inside door handle.

Warning

Use the child locks whenever children are occupying the rear seats.

To close the child security door lock, move the lever up to the lock position.

To open a rear door when the child security door lock is activated, unlock the door from the inside and open the door from the outside.

To cancel the child security door lock, move the lever down to the unlock position.

Doors

Load Compartment

Tailgate, opening



<Type 1>

To open the tailgate, insert the key into the key slot and turn it anticlockwise and then pull the long handle.

The tailgate is locked or unlocked when all doors are locked or unlocked with the key or keyless. When the tailgate is unlocked, pull the long handle to open it.

Warning

Do not drive with the tailgate open or ajar, e.g. when transporting bulky objects, as toxic exhaust gases, could enter the vehicle.

Caution

Before opening the boot lid check overhead obstructions, such as a garage door, to avoid damage of the boot lid. Always check the moving area above and behind the boot lid.

Note: The installation of certain heavy accessories onto the tailgate may affect its ability to remain open.

Tailgate, closing



<Type 1>

To close tailgate, push it down so it latches securely. And insert the key into the key slot and turn it clockwise.

To close tailgate, push it down so it latches securely. It locks automatically when all doors are locked.

Make sure your hands and any other body parts, as well as those of other persons are completely away from the tailgate closure area.

Vehicle Security

Anti-theft Alarm System

Anti-theft alarm system monitors:

- Doors, tailgate, bonnet
- Ignition



Activation

Directly by pressing  button.

2-8 Keys, Doors, and Windows

Status indicator



<Type 1>

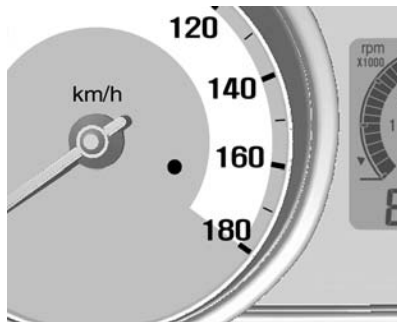

<Type 2>

The security indicator will flash to indicate the anti-theft system is working.

It goes out when doors are unlocked using the keyless entry transmitter.

It comes on when you lock the doors using the keyless entry transmitter.

Deactivation



Unlocking the vehicle by pressing button  deactivates anti-theft alarm system.

Alarm sound

The system provides an alarm when any of the doors, tailgate or bonnet are opened without pressing the unlock button on the transmitter.

To stop the alarm sound, press either the lock or unlock button on the transmitter.

Otherwise, after 28 seconds, the alarm will automatically stop, being reset to the activated anti-theft mode.

If the system does not operate as described above, have it checked by your authorised workshop.

Immobiliser

Immobiliser indicator



<Type 1>

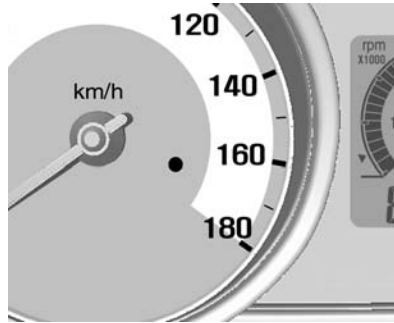

<Type 2>

If an invalid key is used, the indicator will flash and the vehicle can't be started.

Auto door lock

If the door is not opened or the position of the ignition key is not located in ACC or ON within 30 seconds after unlocking the doors using the transmitter, all doors are automatically locked.

Immobiliser

Immobiliser The immobiliser system provides an additional theft deterrent to the vehicle in which it is installed and prevents it from being started by unauthorised persons. The valid key for a vehicle equipped with immobiliser system is an ignition key with integrated transponder, which is electronically coded. The transponder is placed invisibly in the ignition key.

Only valid ignition keys can be used to start the engine.

The engine is automatically immobilised after the key is turned to LOCK and has been removed from the ignition switch.

The immobiliser indicator can be operated in the following conditions:

- If the immobiliser system has a fault (including the Auto Key Learning Mode) when the ignition switch is in ON or

2-10 Keys, Doors, and Windows

START position, the immobiliser indicator flashes or illuminates continuously.

- In some European countries, an auxiliary immobiliser is optional to improve the vehicle security level. If the module is replaced with a new one, the vehicle cannot be started. If the vehicle cannot be started or the immobiliser indicator flashes or illuminates, have the system checked by an authorised workshop.

Exterior Mirrors

Convex Mirrors

The convex exterior mirror reduces blind spots. The shape of the mirror makes objects appear smaller, which will affect the ability to estimate distances.

Manual Mirrors



Adjust the outside rearview mirrors so you can see each side of your vehicle, as well as each side of the road behind you.

Simply move the adjusting lever in the desired direction to adjust the mirror angles.

Power Mirrors



Select the relevant exterior mirror by turning the control to left (L) or right (R). Then swivel the control to adjust the mirror.

Folding Mirrors

Folding mirrors



For pedestrian safety, the exterior mirrors will swing out of their normal mounting position if they are struck with sufficient force. Reposition the mirror by applying slight pressure to the mirror housing.

Warning

Always keep your mirrors properly adjusted, and use them while driving to increase your visibility of objects and other vehicles

(Continued)

2-12 Keys, Doors, and Windows

Warning (Continued)

around you. Do not drive while either outside rearview mirror is folded back.

Heated Mirrors



Type 1



Type 2

Operated by pressing the  button.

Heating works with the engine running and is switched off automatically after a few minutes or by pressing the button again.

Interior Mirrors

Manual Rearview Mirror



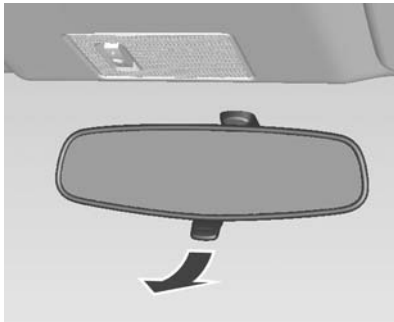

To reduce dazzle, adjust the lever on the underside of the mirror housing.

⚠ Warning

Your view through the mirror may lose some clarity when it is adjusted for night vision.

Take special care with using your inside rearview mirror when it is adjusted for night vision.

(Continued)

Warning (Continued)

Failure to ensure a clear rear view while driving may result in a collision causing damage to your vehicle or other property and/or personal injury.

Windows

Manual Windows



2-14 Keys, Doors, and Windows



The door windows can be opened or closed with the window winders.

Power Windows

Warning

Take care when operating the power windows. Risk of injury, particularly to children.

If there are children on the rear seats, switch on the child safety system for the power windows.

(Continued)

Warning (Continued)

attachment could render the tether strap and top tether anchorage ineffective.

Keep a close watch on the windows when closing them. Ensure that nothing becomes trapped in them as they move.



<Type 1>





<Type 2>

Power windows can be operated with ignition on.

Operate the switch for the respective window by pushing to open or pulling to close.

Operation

You may operate the power windows when the ignition switch is ON by using the power window switches on each door panel.

To open the window, press down on the switch.

To close the window, lift up on the switch.

Release the switch when the window reaches the desired position.

Warning

Body parts outside the vehicle can be struck by passing objects. Keep all parts of body inside vehicle.

Children can operate and become entrapped in power windows.

Do not leave your keys or unattended children in your car.

Serious injury or death can occur from misuse of power windows.

Child safety system for rear windows



<Type 1>

2-16 Keys, Doors, and Windows



<Type 2>



Press switch  to deactivate rear power windows.

To activate press  again.

Heated Rear Window



Type 1



Type 2

Operated by pressing the  button.

Heating works with the engine running and is switched off automatically after a few minutes or by pressing the button again.

 **Caution**

Do not use sharp instruments or abrasive window cleaners on your vehicle's rear window.

Do not scratch or damage the defroster wires when you clean or work around the rear window.

Sun Visors

The sun visors can be folded down or swivelled to the side to prevent dazzling.

If the sun visors have integral mirrors, the mirror covers should be closed when driving.

 **Warning**

Do not place the sun visor in such a manner that it obscures visibility of the roadway, traffic or other objects.

Seats and Restraints

Head Restraints

Head Restraints 3-1

Front Seats

Seat Position 3-3

Seat Adjustment 3-4

Heated Front Seats 3-6

Safety Belts

Safety Belts 3-6

Three-Point Safety Belt 3-8

Airbag System

Airbag System 3-11

Front Airbag System 3-12

Side Airbag System 3-13

Curtain Airbag System 3-15

Airbag On-Off Switch 3-16

Child Restraints

Child Restraint Systems 3-17

Child Restraint Installation

Locations 3-19

ISOFIX Child Restraint

Systems 3-21

Top Tether Child Restraint

Systems 3-24

Head Restraints

Position



Warning

Only drive with the head restraint set to the proper position.

Removed or improperly adjusted head restraints can result in serious head and neck injuries in case of a collision.

Make sure that the head restraint readjusted before driving.

3-2 Seats and Restraints

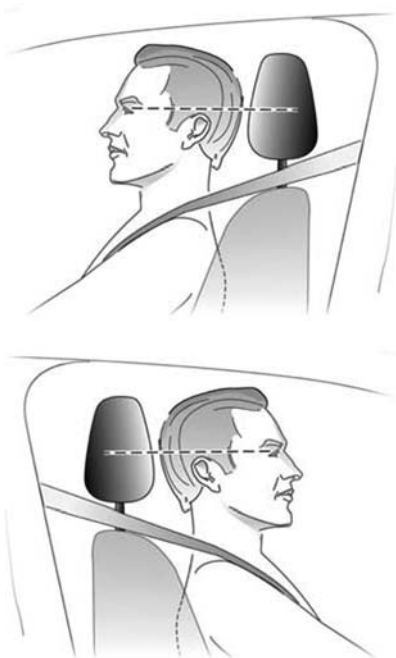

The upper edge of the head restraint should be at upper head level. If this is not possible for

extremely tall people, set to highest position, and set to lowest position for small people.

Head restraints on front seats

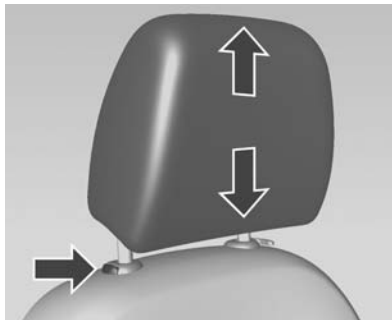

Height adjustment

Pull the head restraint upwards. To move down press the catch and push the head restraint downwards.

Press the catches and pull up the head restraint.

Head restraints on rear seats

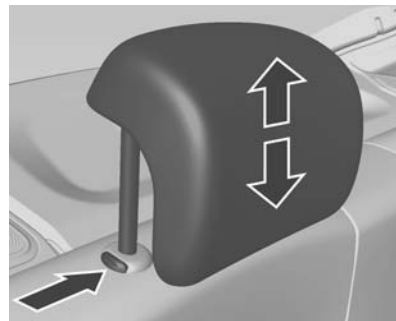

Height adjustment

Pull the head restraint upwards. To move down press the catch and push the head restraint downwards.

Press the catches and pull up the head restraint.

Front Seats

Seat Position

 **Warning**

Only drive with the seat correctly adjusted.



Removing



- Sit with buttocks as far back against the backrest as possible. Adjust the distance between the seat and the pedals so that legs are slightly angled when pressing the pedals. Slide the front passenger seat as far back as possible.
- Sit with shoulders as far back against the backrest as possible. Set the backrest rake so that it is possible to easily reach the steering wheel with arms slightly bent. Maintain contact between shoulders and the backrest when turning the steering wheel. Do not angle the backrest too far back. We recommend a maximum rake of approx. 25°.
- Adjust the steering wheel ⇨ *Steering Wheel Adjustment on page 5-2.*
- Set the seat high enough to have a clear field of vision on all sides and on all display instruments. There should be at least one hand of clearance

3-4 Seats and Restraints

between your head and the headlining. Your thighs should rest lightly on the seat without pressing into it.

- Adjust the head restraint ⇨ *Head Restraints on page 3-1.*
- Adjust the height of the seat belt ⇨ *Three-Point Seat belt on page 3-8.*

Seat Adjustment

Danger

Do not sit nearer than 25 cm(10 inches) to the steering wheel, to permit safe airbag deployment.

Warning

Never adjust seats while driving as they could move uncontrollably.

Seat positioning

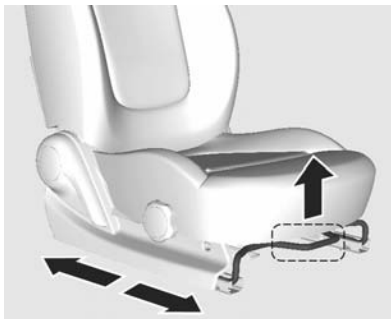

Pull handle, slide seat, release handle.

Warning

When positioning seat, ensure the grip zone in the centre of the release bar is used.

Seat backrests





Pull lever, adjust inclination and release lever. Allow the seat to engage audibly.

Do not lean on seat when adjusting.

Seat height

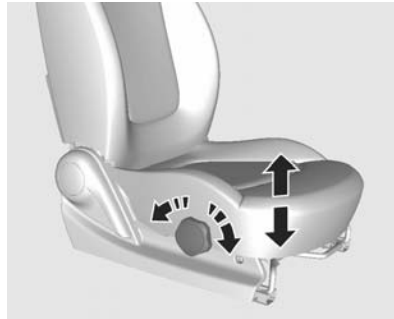
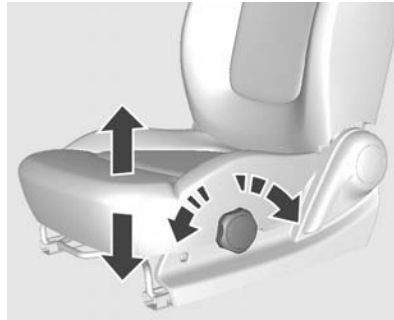

Turn the handwheel on the outside of the seat cushion until the seat cushion is adjusted to the desired position.

3-6 Seats and Restraints

Heated Front Seats

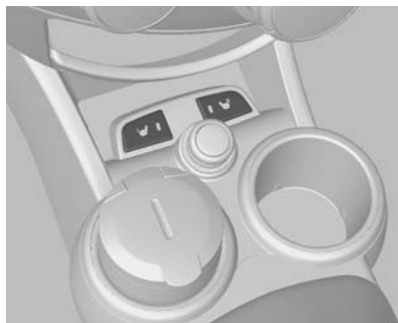

Type 1



Type 2

The seat heater buttons are located in the front console.

To warm the seat:

1. Turn the ignition key on.
2. Press the seat heating button for the seat that you want to warm. The indicator in the button will illuminate.
3. To turn off the seat heater, press the button again.

Prolonged use of the highest setting for people with sensitive skin is not recommended.

Seat heating is operational when engine is running.

Safety Belts

Seat belts





The belts are locked during heavy acceleration or deceleration of the vehicle for the safety of the occupants.

Warning

Fasten safety belt before each trip.

In the event of an accident, people not wearing safety belts endanger their fellow occupants and themselves.

Seat belts are designed to be used by only one person at a time. They are not suitable for people smaller than 150 cm (5 ft). Child restraint system ⇨ *Child Restraint Systems on page 3-17.*

Periodically check all parts of the belt system for damage and proper functionality.

Have damaged components replaced. After an accident, have the belts and triggered belt pretensioners replaced by a workshop.

Note: Make sure that the belts are not damaged by shoes or sharp-edged objects or trapped. Prevent dirt from getting into the belt retractors.

Seat belt reminder  ⇨ *Safety Belt Reminders on page 5-15.*

Belt force limiters

On the front seats, stress on the body is reduced by the gradual release of the belt during a collision.

Belt pretensioners





3-8 Seats and Restraints

In the event of a head-on or side or rear-end collision of a certain severity, the front seat belts are tightened.

Warning

Incorrect handling (e.g. removal or fitting of belts) can trigger the belt tensioners with risk of injury.

Deployment of the belt pretensioners is indicated by illumination of control indicator   *Safety Belt Reminders on page 5-15.*

Triggered belt pretensioners must be replaced by a workshop. Belt pretensioners can only be triggered once.

Note: Do not affix or install accessories or other objects that may interfere with the operation of the belt pretensioners. Do not make any modifications to belt pretensioner components as this will invalidate the vehicle type approval.

Three-Point Safety Belt Fastening



Withdraw the belt from the retractor, guide it untwisted across the body and insert the latch plate into the buckle.

Tighten the lap belt regularly whilst driving by pulling the shoulder belt. Seat belt reminder  *Safety Belt Reminders on page 5-15.*



Loose or bulky clothing prevents the belt from fitting snugly. Do not place objects such as handbags or mobile phones between the belt and your body.

 Warning
The belt must not rest against hard or fragile objects in the pockets of your clothing.

Height adjustment

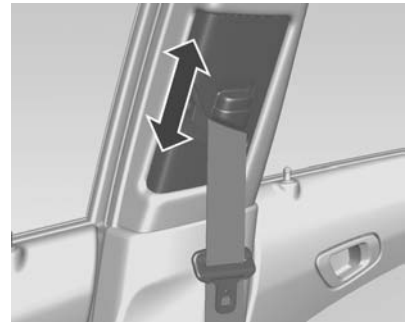

1. Press button.
 2. Adjust height and engage.
- Adjust the height so that the belt lies across the shoulder. It must not lie across the throat or upper arm.

3-10 Seats and Restraints

Removing

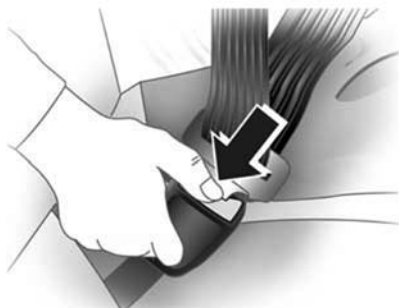

To release belt, press red button on belt buckle.

Seat belts on the rear seats

The seat belt for the rear centre seat can only be withdrawn from the retractor if the backrest is in the rear position.

Seat belt use during pregnancy



Warning

The lap belt must be positioned as low as possible across the pelvis to prevent pressure on the abdomen.

Seat belts work for everyone, including pregnant women.

Like all occupants, pregnant women are more likely to be seriously injured if they do not wear seat belts.

In addition, when a seat belt is worn properly, it is more likely that the unborn child will be safe in a crash.

To provide maximum protection, a pregnant woman should wear a seat belt.

She should wear the lap portion of the belt as low as possible throughout her pregnancy.

Airbag System

Airbag system

The airbag system consists of a number of individual systems.

When triggered the airbags inflate within milliseconds. They also deflate so quickly that it is often unnoticeable during the collision.

Warning

If handled improperly the airbag systems can be triggered in an explosive manner.

The driver should sit back as far as possible while still maintaining control of the vehicle. If you are sitting too close to the airbag, it can cause death or serious injury when it inflates.

For maximum safety protection in all types of crashes, all occupants including the driver should always

(Continued)

Warning (Continued)

wear their seat belts to minimise the risk of severe injury or death in the event of a crash. Do not sit or lean unnecessarily close to the airbag while the vehicle is in motion.

The airbag may cause facial or body scratch, injury by broken glasses or getting burnt by explosion while airbag is deployed.

Note: The airbag systems and belt tensioner control electronics are located in the central console area. Do not put any magnetic objects in this area.

Do not stick anything on the airbag covers and do not cover them with other materials.

Each airbag is triggered only once. Have deployed airbags replaced by a repairer.

3-12 Seats and Restraints

Do not make any modifications to the airbag system as this will invalidate the vehicle type approval.

In the event of airbag deployment have the steering wheel, the instrument panel, all panelling parts, the door seals, the handles and the seats removed by a repairer.

When an air bag deploys, there may be a loud noise and smoke. These conditions are normal and are not dangerous but in case it may stimulate skin of the passenger. If the stimulation is continued, contact a doctor.

Danger

Never allow children or infants and pregnant women and the old and the weak sit in the front passenger seats fitted with airbags.

(Continued)



Danger (Continued)

Furthermore, do not drive with a baby seat fitted thereon. In case of an accident, the impact from the inflated airbag can cause facial injury or death.

Caution

If the vehicle is impacted by bumps or objects on unpaved roads or pavements, the airbags may inflate. Drive slowly on surfaces not designed for vehicle traffic to prevent unintended airbag deployment.

When the airbags inflate, escaping hot gases may cause burns.

Control indicator  for airbag systems  *Airbag and Seat belt Tensioner Light on page 5-16.*

Front Airbag System

The front airbag system consists of one airbag in the steering wheel and one in the instrument panel on the front passenger side. These can be identified by the word AIRBAG.

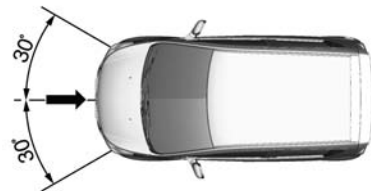

The front airbag system is triggered in the event of an accident of a certain severity in the depicted area. The ignition must be on.

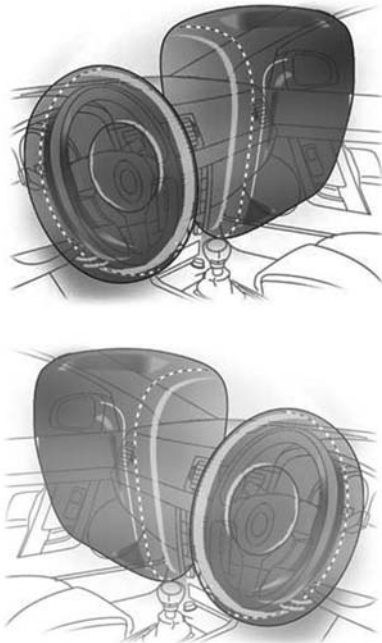

The forward movement of the front seat occupants is retarded, thereby considerably reducing the risk of injury to the upper body and head.

⚠ Warning

Optimum protection is only provided when the seat is in the proper position

⇒ *Seat Position on page 3-3.*

Keep the area in which the airbag inflates clear of obstructions.

Fit the seat belt correctly and engage securely. Only then the airbag is able to protect.

Side Airbag System

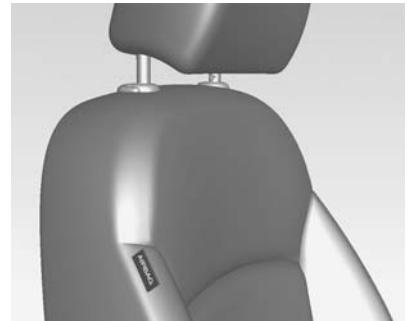
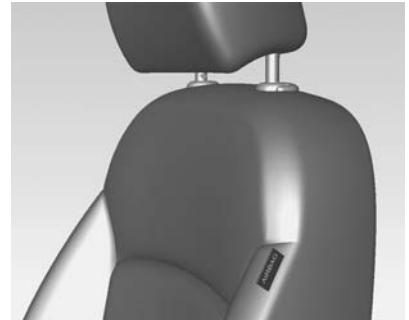

3-14 Seats and Restraints

The side airbag system consists of an airbag in each front seat backrest.

This can be identified by the word AIRBAG.

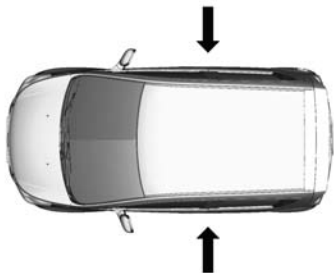

The side airbag system is triggered in the event of an accident of a certain severity. The ignition must be on.

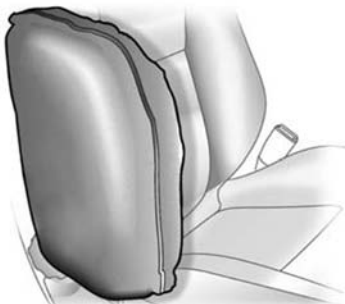
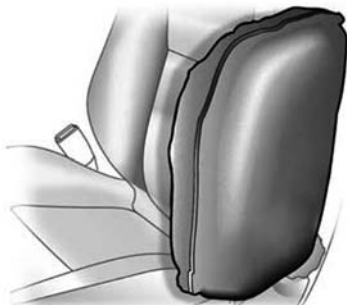

The risk of injury to the upper body and pelvis in the event of a side-on collision is considerably reduced.

Warning

Keep the area in which the airbag inflates clear of obstructions.

Note: Only use protective seat covers that have been approved for the vehicle. Be careful not to cover the airbags.

Warning

Children who are seated in close proximity to a side airbag may be at risk of serious or fatal injury if the airbag deploys, especially if the child's head, neck, or chest is close to the airbag at the time of deployment.

Never let your child lean on the door or close to the side airbag module.

Curtain Airbag System



The curtain airbag system consists of an airbag in the roof frame on each side. This can be identified by the word AIRBAG on the roof pillars.

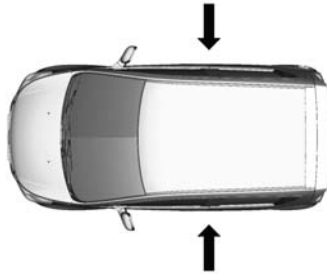

The curtain airbag system is triggered in the event of an accident of a certain severity. The ignition must be on.

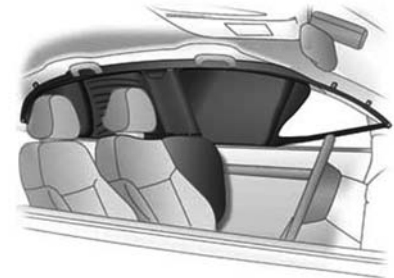

The risk of injury to the head in the event of a side impact is considerably reduced.

⚠ Warning

Keep the area in which the airbag inflates clear of obstructions.

The hooks on the handles in the roof frame are only suitable for hanging up light articles of clothing, without coat hangers. Do not keep any items in these clothes.

3-16 Seats and Restraints

Airbag On-Off Switch

The front passenger airbag system has to be deactivated if a child restraint system is to be fitted on this seat. The side airbag and curtain airbag systems, the belt tensioners and all driver airbag systems will remain active.





Front passenger airbag system can be deactivated via a lock on the side of the instrument panel, visible when the front passenger door is open.

Warning

Deactivate front passenger airbag system when the front passenger seat is occupied by a child.

Activate front passenger airbag system when an adult is on the front passenger seat.

Use the ignition key to choose the position:

 off = front passenger airbags are deactivated and will not inflate in the event of a collision. Control indicator  off illuminates continuously. A child restraint system can be installed in accordance with the chart.

 on = front passenger airbags are activated. No child restraint systems can be installed.



As long as the control indicator  off is not illuminated, the airbag systems for the front passenger seat will inflate in the event of a collision.

Change status only when the vehicle is stopped with the ignition off.

Status remains until the next change.

Control indicator for airbag 
Airbag On-Off Light on page 5-16.

Child Restraints

Child Restraint Systems

We recommend the GM child restraint system which is geared specifically to the vehicle.

When a child restraint system is being used, pay attention to the following usage and installation instructions and also those supplied with the child restraint system.

Always comply with local or national regulations. In some countries, the use of child restraint systems is forbidden on certain seats.



Warning

NEVER use a rearward facing child restraint on a seat protected by an ACTIVE AIRBAG in front of it, DEATH or SERIOUS INJURY to the CHILD can occur.

Warning

When using a child restraint system on the front passenger's seat, the airbag systems for the front passenger's seat must be deactivated; if not, the triggering of the airbags poses a risk of fatal injury to the child.

This is especially the case if rear facing child restraint systems are used on the front passenger's seat.

Airbag deactivation ⇨ *Airbag On-Off Switch on page 3-16.*

Selecting the right system

Children should travel facing rearwards in the vehicle as long as possible. This makes sure that the child's backbone, which is still very weak, is under less strain in the event of an accident.

3-18 Seats and Restraints

Children under the age of 12 years that are smaller than 150 cm(5 ft) are only allowed to travel in a restraint system that is suitable for the child. Suitable are restraint systems that comply with ECE 44-03 or ECE 44-04. Since a proper position of the belt is rarely possible with a child that is smaller than 150 cm(5 ft), we strongly advise to use an appropriate child restraint system, even though this might due to the age of the child no longer be legally binding.

Check local laws and regulations for mandatory use of child restraint systems.

Never carry a child whilst travelling in the vehicle. The child will become too heavy to hold in the event of a collision.

When transporting children, use the child restraint systems suitable for the child's weight.

Ensure that the child restraint system to be installed is compatible with the vehicle type.

Ensure that the mounting location of the child restraint system within the vehicle is correct.

Allow children to enter and exit the vehicle only on the side facing away from the traffic.

When the child restraint system is not in use, secure the seat with a seat belt or remove it from the vehicle.

Note: Do not stick anything on the child restraint systems and do not cover them with any other materials.

A child restraint system which has been subjected to stress in an accident must be replaced.

Please ensure that infants and children are seated in the rear seats using child restraints.

Until the children can use seat belts, please select a child restraint suitable for its age and make sure the child wears it. Please see the instructions on the relevant products for child restraints.

Child Restraint Installation Locations

Permissible options for fitting a child restraint system

Weight and age class	On front passenger seat		On rear outboard seats	On rear centre seat
	activated airbag	deactivated airbag		
Group 0: up to 10 kg or approx. 10 months	X	U1	U2	U
Group 0+: up to 13 kg or approx. 2 years	X	U1	U2	U
Group I: 9 to 18 kg or approx. 8 months to 4 years	X	U1	U2	U
Group II: 15 to 25 kg or approx. 3 to 7 years	X	X	U	U
Group III: 22 to 36 kg or approx. 6 to 12 years	X	X	U	U

1: Only if front passenger seat airbag systems are deactivated. If the child restraint system is being secured using a three-point seat belt, ensure that the vehicle seat belt runs forwards from the upper anchorage point.

2: Seat available with ISOFIX and Top-Tether mounting brackets.

U: Universal suitability in conjunction with three-point seat belt.

X: No child restraint system permitted in this weight class.

3-20 Seats and Restraints

Permissible options for fitting an ISOFIX child restraint system

Weight Class	Size Class	Fixture	On front passenger seat	On rear outboard seats	On rear centre seat
Group 0: up to 10 kg	E	ISO/R1	X	IL (1)	X
Group 0+: up to 13 kg	E	ISO/R1	X	IL (1)	X
	D	ISO/R2	X	IL (1)	X
	C	ISO/R3	X	IL (1)	X
Group I: 9 to 18 kg	D	ISO/R2	X	IL (1)	X
	C	ISO/R3	X	IL (1)	X
	B	ISO/F2	X	IL, IUF	X
	B1	ISO/F2X	X	IL, IUF	X
	A	ISO/F3	X	IL, IUF	X

(1) Move front passenger seat to most forward position or move forward until child restraint system does not have any interference with front seat backrest.

IL: Suitable for particular ISOFIX restraint systems of the 'specific-vehicle', 'restricted' or 'semi-universal' categories.

The ISOFIX restraint system must be approved for the specific vehicle type.

IUF: Suitable for ISOFIX forward-facing child restraint systems of universal category approved for use in this mass group.

X: No ISOFIX child restraint system approved in this weight class.

ISOFIX size class and seat device

A - ISO/F3: Forward-facing child restraint system for children of maximum size in the weight class 9 to 18 kg.

B - ISO/F2: Forward-facing child restraint system for smaller children in the weight class 9 to 18 kg.

B1 - ISO/F2X: Forward-facing child restraint system for smaller children in the weight class 9 to 18 kg.

C - ISO/R3: Rear-facing child restraint system for children of maximum size in the weight class up to 13 kg.

D - ISO/R2: Rear-facing child restraint system for smaller children in the weight class up to 13 kg.

E - ISO/R1: Rear-facing child restraint system for young children in the weight class up to 13 kg.

ISOFIX Child Restraint Systems



In the past, child restraints have been attached to a vehicle's seat by seat belts. As a result, child restraints were often installed incorrectly or too loosely to adequately protect your child.

We now equip your vehicle with ISOFIX low anchorages at the two rear outboard seating positions and with Top-tether anchorages in the rear seat backward (Notchback-back of headrests / Hatchback-back of rear seat backrest panels) allowing child restraints to be attached to the rear seats.

3-22 Seats and Restraints

To install a child restraint which comes equipped with ISOFIX low and Top-tether anchorage attachments, follow the instructions supplied with your child restraint.

Please take the time to carefully read and follow all of the instructions on the following pages and the instructions supplied with your child restraint.

Your child's safety depends on it!

If you have questions, or any doubts whether you have installed your child restraint properly, contact the child restraint manufacturer. If you are still having trouble installing the child restraint in your vehicle, we recommend that you consult your authorised workshop.

Installation of ISOFIX child restraint systems:

1. Select one of the rear outboard seating positions for installation of the child restraint.



2. Locate the two lower anchor positions. The location of each lower anchor is identified with a circular marking on the lower edge of the rear seat backrest.
3. Make sure there are no foreign objects around lower anchors, including seat belt buckles or seat belts. Foreign objects can interfere with the proper latching of the child restraint to the anchors.
4. Place the child restraint on the seat over the two lower anchors and attach it to the anchors following the instructions supplied with the child restraint.
5. Adjust and tighten the child restraint according to the instructions supplied with the child restraint.

 **Caution**

Unused child restraint system could move forward.

Remove child restraint system if not in use, or secure it with seat belt.

Note: Since a seat belt or child restraint system can become very hot if it is left in a closed vehicle, be sure and check the seat cover and buckles before placing a child there.

 **Warning**

Use all ISOFIX low and top tether anchorages for their designed purpose only.

ISOFIX low and top tether anchorages are designed only to hold child restraints which come equipped with low and top anchorage attachments.

(Continued)

Warning (Continued)

Do not use ISOFIX low and top tether anchorages to hold adult seat belts, harnesses, or other items of equipment in your vehicle.

Using ISOFIX low and top tether anchorages to hold adult seat belts, harnesses, or other items or equipment in your vehicle will not provide adequate protection in the case of a collision and could result in injuries or even death.

 **Warning**

Child restraint system placed in the front seat could cause serious injury or death.

(Continued)

Warning (Continued)

Never install a rear-facing child restraint in the front seat of a vehicle equipped with a front passenger air bag.

A child in a rear-facing child restraint installed in the front seat can be seriously injured if the front passenger air bag inflates.

Secure a rear-facing child restraint in the rear seat.

A front-facing child restraint should be secured in the rear seat whenever possible.

If installed in the front passenger seat, adjust the seat as far back as it will go.

Caution

Full size rear facing child seats may not be suitable for installation. Contact your retailer for information regarding suitable child restraint systems.

Installation of child restraints with ISOFIX low and top tether anchorage attachments.

Top Tether Child Restraint Systems

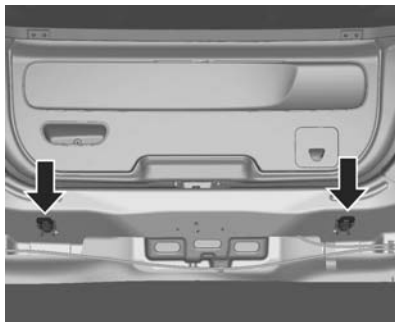

To access the Top-tether anchor points, do the following:

1. Remove the foreign objects around the top tether anchor.
Notchback: Open the cover and pull the anchor upward.
Hatchback: Remove the load compartment cover.

2. Attach the clip on the child restraint's tether strap to the Top-tether anchor, making sure to remove any twists in the tether strap. If the position you are using has an adjustable head restraint and you are using a single tether, raise the head restraint and route the tether under the head restraint and in between the head restraint posts.

If the position you are using has an adjustable head restraint and you are using a dual tether, route the tether around the head restraint.

If the position you are using has an adjustable head restraint and you are using a single tether, raise the head restraint and route the tether under the head restraint and in between the head restraint posts.

3. Tighten the child restraint's tether strap according to the instructions supplied with the child restraint.
4. Push and pull on the child restraint after installation to be sure the child restraint is secure.

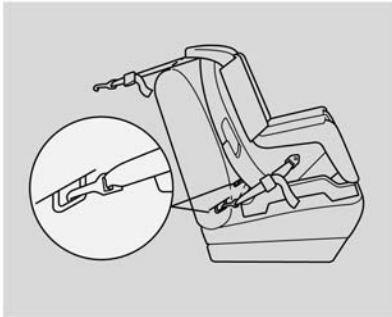

Warning

Make sure the clip on the child restraint's tether strap is properly attached to the Top-tether anchorage.

Incorrect attachment could render the tether strap and top tether anchorage ineffective.

Storage

Storage Compartments

Storage Compartments	4-1
Instrument Panel Storage	4-1
Glove Box	4-2
Cupholders	4-3

Luggage/Load Locations

Load Compartment	4-4
------------------------	-----

Additional Storage Features

Convenience Net	4-6
-----------------------	-----

Roof Rack System

Roof Rack System	4-7
------------------------	-----

Information on Loading the Vehicle

Information on Loading the Vehicle	4-7
------------------------------------------	-----

Storage Compartments

Warning

Do not store heavy or sharp objects in the storage compartments. Otherwise, the storage compartment lid could open and vehicle occupants could be injured by objects being thrown around in the event of hard braking, a sudden change in direction or an accident.

Instrument Panel Storage

Storage below the instrument panel



Type 1

4-2 Storage



Type 2

The storage is used for small articles, etc.

Coin box

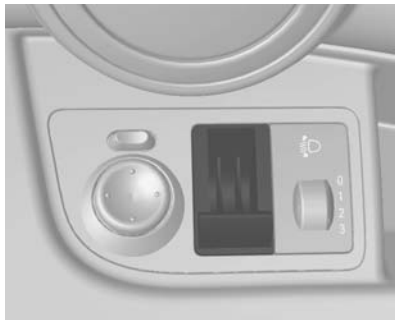

Store your coins in a place.

Glove Box

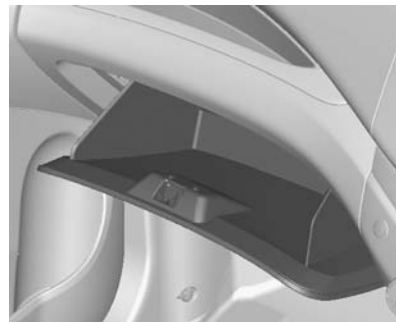
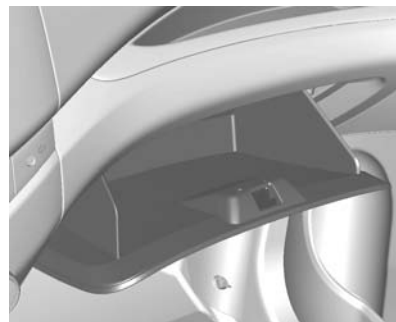

To open pull the grip.

Warning

To reduce the risk of injury in an accident or a sudden stop, always keep the glovebox door closed while driving.

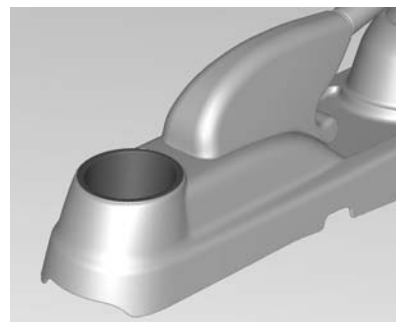
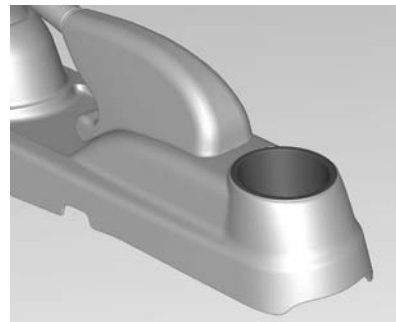
Cupholders**Type 1****Type 2**

The cup holders are located in the front console and rear part of the centre console.

Warning

Do not place uncovered cups of hot liquid in the cup holder while the vehicle is in motion. If the hot liquid spills, you burn yourself. Such a burn to the driver could lead to loss of control of the vehicle.

To reduce the risk of personal injury in the event of sudden stop or collision, do not place uncovered or unsecured bottles, glasses, cans, etc., in the cup holder while the vehicle is in motion.

Luggage/Load Locations

Load Compartment

Folding down rear backrests

Warning

Do not stack luggage or other cargo higher than the front seats.

Do not allow passengers to sit on the folded seat backrests while the vehicle is in motion.

Unrestrained load or passengers on a folded seat backrest can be thrown around within or ejected from the vehicle in a sudden stop or accident. This can result in serious injuries or death.

To fold down the rear backrest separately:

1. Pull up the front of the rear seat cushion to release it. If your vehicle is equipped with rear seat head restraints, they must be removed.
2. Guide the released rear seat cushion to an upright position.

Note: To ensure enough room for rear seat cushion operation, slide the front seat forward and adjust the front seat backrest upright.

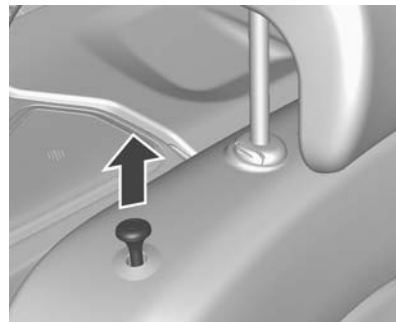

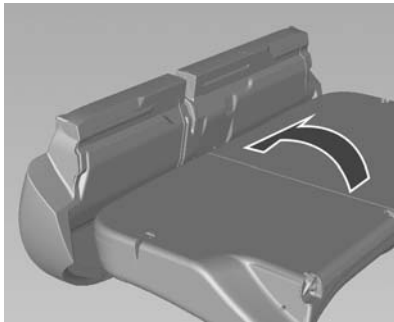

4. Adjust the front seats to the desired position.

To return the backrest to the upright position, lift it up and push it firmly into place.

Make sure the seat belts are not pinched by the latch.

To return the rear seat cushion, put the rear part of the seat cushion in its original position ensuring that the seat belt buckle straps are not twisted or caught under the seat cushion, then push the front part of the seat cushion firmly down until it latches.

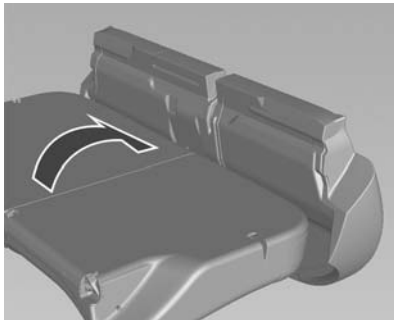

3. Pull up the release knob on top of the rear seat backrest and fold it forward and down.

⚠ Caution

When returning rear seat backrest to the upright position, place the rear seat belt and buckles between the rear seat backrest and one cushion. Make sure the
(Continued)

Caution (Continued)

rear seat belt and buckles do not get pinched under the rear seat cushion.

Make sure the seat belts are not twisted or caught in the seat backrest and are arranged in their proper position.

⚠ Warning

Ensure that the rear seat backrests are all the way back and locked in position before operating the vehicle with passengers on the rear seat.

Do not pull the release knobs on the top of the seat backrest while the vehicle is moving.

It can cause injuries or damage to the occupants.

Caution

Folding a rear seat with the seat belts still fastened may cause damage to the seat or the seat belts.

Always unbuckle the seat belts and return them to their normal stowed position before folding a rear seat.

Warning

Never allow passengers to sit on top of the folded down backrests, while the car is moving as this is not a proper seating position and no seat belts are available for use.

This could result in serious injury or death in case of an accident or sudden stop.

(Continued)

Warning (Continued)

Objects carried on the folded down backrest should not extend higher than the top of the front seats. This could allow cargo to slide forward and cause injury or damage during sudden stops.

Additional Storage Features

Convenience Net

You can carry small loads with your optional convenience net.

To install the net, hang each loop in the upper corner of the net to both anchors of the back panel.

Caution

The convenience net is designed for small loads. Do not carry heavy objects in your convenience net.

Roof Rack System

Roof rack

For safety reasons and to avoid damage to the roof, the vehicle approved roof rack system is recommended.

If you try to carry something on top of your vehicle that is longer or wider than the roof rack, the wind can catch it as you drive along. This can cause you to lose control. What you are carrying could be torn off violently, and this could cause you or other drivers to have a collision, and of course damage your vehicle. Never carry something longer or wider than the roof rack on top of your vehicle.

The maximum load (include roof utility bar's weight) for the roof rack rails is 50 kg in the vehicle. Do not exceed the maximum vehicle capacity when loading your vehicle.

Remove the roof utility bar or luggage, in the auto car washing facility, in case of there are roof utility bar or luggage on the roof rack.

Information on Loading the Vehicle

- Heavy objects in the load compartment should be placed against the seat backrests. Ensure that the backrests are securely engaged. If objects can be stacked, heavier objects should be placed at the bottom.
- Secure objects in load compartment to prevent sliding.
- When transporting objects in the load compartment, the backrests of the rear seats must not be angled forward.
- Do not allow the load to protrude above the upper edge of the backrests.
- Do not place any objects on the load compartment cover or the instrument panel, and do not cover the sensor on top of the instrument panel.

4-8 Storage

- The load must not obstruct the operation of the pedals, parking brake and gear selector lever, or hinder the freedom of movement of the driver. Do not place any unsecured objects in the interior.
- Do not drive with an open load compartment.
- The payload is the difference between the permitted gross vehicle weight (see identification plate → *Identification Plate on page 12-1*) and the kerb weight. For the kerb weight in detail, refer to the technical data section.

The kerb weight includes weights for the driver (68 kg), luggage (7 kg) and all fluids (tank 90 % full).

Optional equipment and accessories increase the kerb weight.

- Driving with a roof load increases the sensitivity of the vehicle to cross-winds and has a detrimental effect on vehicle handling due to the vehicle's higher centre of gravity. Distribute the load evenly and secure it properly with retaining straps. Adjust the tyre pressure and vehicle speed according to the load conditions. Check and retighten the straps frequently.

Instruments and Controls

Controls

Steering Wheel Adjustment ...	5-2
Steering Wheel Controls	5-2
Horn	5-3
Windscreen Wiper/Washer	5-3
Rear Window Wiper/ Washer	5-5
Clock	5-6
Power Sockets	5-7
Cigarette Lighter	5-7
Ashtrays	5-9

Warning Lights, Gauges, and Indicators

Speedometer	5-10
Mileometer	5-10

Rev Counter	5-11
Fuel Gauge	5-12
Control Indicators	5-12
Transmission Display	5-15
Indicator	5-15
Seat Belt Reminders	5-15
Airbag and Safety Belt Tensioner Light	5-16
Airbag On-Off Light	5-16
Charging System Light	5-17
Malfunction Indicator Lamp	5-17
Brake System Warning Light	5-17
Antilock Brake System (ABS) Warning Light	5-17
Up-Shift Light	5-17
Overdrive Off Light	5-18
Electronic Stability Control (ESC) Indicator Light	5-18

Electronic Stability Control (ESC) Off Light	5-18
Engine Coolant Temperature Warning Light	5-18
Tyre Pressure Monitoring System Light	5-18
Engine Oil Pressure Light	5-19
Low Fuel Warning Light	5-19
Main-Beam On Light	5-19
Front Fog Lamp Light	5-19
Rear Fog Lamp Light	5-20
Door Ajar Light	5-20

Trip Computer

Trip Computer	5-20
---------------------	------

Vehicle Personalisation

Vehicle Personalisation	5-23
-------------------------------	------

Controls

Steering Wheel Adjustment



Unlock lever, adjust steering wheel, then engage lever and ensure it is fully locked.

Do not adjust steering wheel unless vehicle is stationary and steering wheel lock has been released.

Caution

If a strong impact is delivered to the steering column when the steering wheel is adjusted or the lever is locked, it may cause damage to the parts related to steering wheel.

Steering Wheel Controls

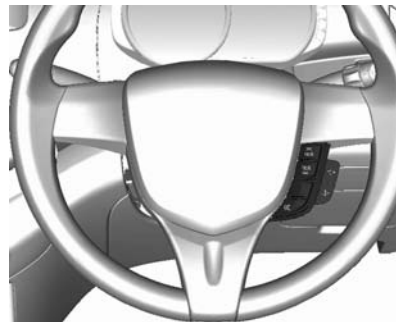

The Infotainment system can be operated by the controls on the steering wheel ⇨ *Overview on page 7-3*

Horn

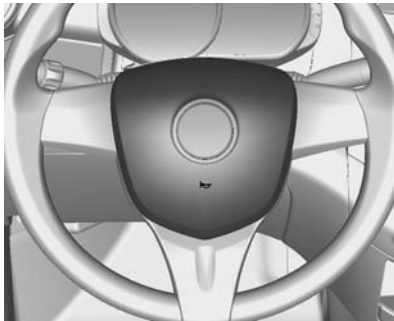

Press .

Windscreen Wiper/ Washer

Windscreen wiper

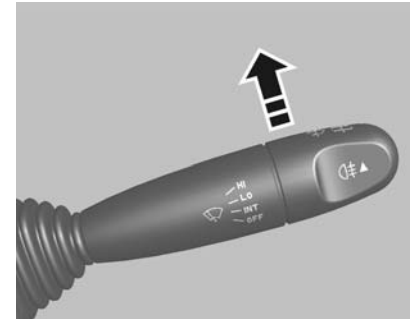

To operate the windscreen wipers, turn the ignition ON and move the windscreen wiper / washer lever upward.

OFF: System off.

INT: Intermittent operation.

LO : Continuous wipe, slow speed.

HI : Continuous wipe, fast speed.

5-4 Instruments and Controls

For a single wipe when the windscreen wipers are off, lightly move the windscreen wiper lever toward the INT position and release it. The lever will return automatically to its normal position when released. The wipers will operate through one cycle.

Misting function

To operate the windscreen wipers once in case of light rain or mist, lightly move the windscreen wiper / washer lever toward the INT position and release it. The lever will return automatically to its normal position when released. The wipers will operate through one cycle.

Caution

Less than clear vision for the driver can lead to an accident resulting in personal injury and damage to your vehicle or other property.

(Continued)

Caution (Continued)

Do not operate the windscreen wipers when the windscreen is dry or obstructed, as with snow or ice.

Using the wipers on an obstructed windscreen can damage the wiper blades, wiper motor and glass.

Check blades are not frozen to windows before operating in cold weather. Wiper operation while blade is frozen can damage wiper motor.

Windscreen washer



Pull lever. Washer fluid is sprayed onto the windscreen and the wiper wipes a few times.

Caution

Do not operate the windscreen washer continuously for more than a few seconds, or when the washer fluid tank is empty. This can cause the washer motor to overheat resulting in costly repairs.

⚠ Warning

Do not spray washer fluid on the windshield in freezing weather. Using washer fluid and wipers in freezing weather may cause an accident because the washer fluid can form ice on a frozen windshield and obstruct your vision.

Rear Window Wiper/Washer**Rear window wiper/washer**

To operate the rear wiper and washer, push the lever toward the instrument panel. Push once: the wiper will operate continuously at slow speed. To spray washer fluid, push the lever once more.

⚠ Caution

Less than clear vision for the driver can lead to an accident resulting in personal injury and damage to your vehicle or other property.

Do not operate the rear window wiper when the tailgate window is dry or obstructed, as with snow or ice.

Using the wiper on an obstructed window can damage the wiper blades, wiper motor, and glass.

Check blade is not frozen to window before operating in cold weather to prevent damage to the wiper motor.

At freezing temperature do not spray washer fluid on the rear window until it is warm.

Washer fluid can form ice on a frozen tailgate window and obstruct your vision.

5-6 Instruments and Controls

Caution

Do not operate the windscreen washer continuously for more than some seconds, or when the washer fluid tank is empty. This can cause the washer motor to overheat resulting in costly repairs.

Clock

<Type 1>



<Type 2>



Time is shown in the cluster.

If the clock is not equipped in the cluster, time is shown in the information system.

Set time

<Type 1>

Push the CLOCK button of the cluster for more than 1 second. When the hour display flashes, adjust the current hour using the CLOCK button.

After approximately 1 second, the minute display will flash automatically then adjust the current minute using the CLOCK button. The setting will be finished without any operation a few seconds after adjusting.

<Type 2>

Press MENU button until the lower display area flashes.

Press the SET/CLR button for more than 2 seconds and then it shifts into the setting mode.

When the hour display flashes, select the hour by using the Δ or ∇ button (if the hour display flashes without any operation for more than 30 seconds, the time will return to the setting mode entry time)

Press SET/CLR button after selecting the hour and then the minute display is flashing.

Select the minute by using the Δ or ∇ button (if the minute display flashes without any operation for

more than 30 seconds, the time will return to the setting mode entry time).

Press the SET/CLR button after the minute setting is completed.

Power Sockets

<Type 1>

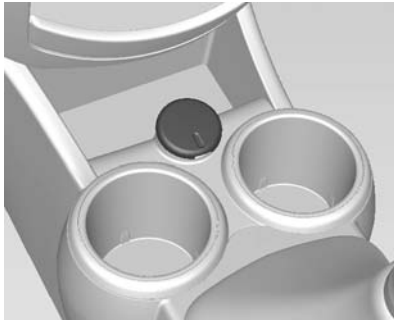

<Type 2>



A 12 Volt power socket is located in the front console.

Do not exceed the maximum power consumption of 120 Watts.

With ignition off, the power sockets are deactivated.

Additionally the power sockets are deactivated in the event of low battery voltage.

Do not connect any current-delivering accessories, e.g. electrical charging devices or batteries.

Do not damage the outlet by using unsuitable plugs.

Cigarette Lighter

Type 1



5-8 Instruments and Controls

Type 2



To operate the cigarette lighter, turn the ignition switch to ACC or ON and push the lighter in all the way.

The cigarette lighter will pop out automatically when it is ready to use.

Caution

Overheating the cigarette lighter can damage the heating element and the lighter itself.

(Continued)

Caution (Continued)

Do not press the lighter while it is heating. This can cause the lighter to overheat.

Trying to operate a malfunctioning cigarette lighter can be dangerous. If the heated cigarette lighter does not pop out within 25 seconds, pull it out and consult a workshop to have it repaired. It can cause injuries and damage to your vehicle.

Warning

If you leave the vehicle with an inflammable explosive substance, such as a disposable lighter, inside the car in summer, it can explode and cause fire due to an increase of temperature in the passenger compartment and the

(Continued)

Warning (Continued)

boot. Please ensure that no inflammable explosive substances are left or kept inside the car.

Caution

The cigarette socket should only be used with the cigarette lighter.

If other 12 V power adapters are installed into the cigarette socket, fuse failure or a potential thermal incident may occur.

Caution

The barrel of an operating cigarette lighter can become very hot.

(Continued)

Caution (Continued)

Do not touch the barrel of the cigarette lighter and do not allow children to operate or play with the cigarette lighter.

The hot metal can cause personal injuries and damage to your vehicle or other property.

Ashtrays

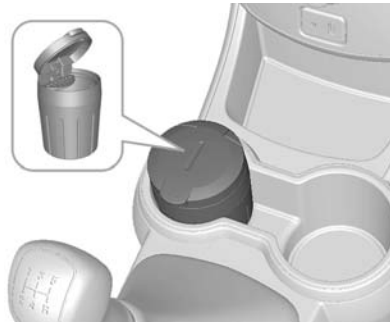

⚠ Caution

Cigarettes and other smoking materials could set them on fire.

Do not put paper or other flammable items in the ashtray.

An ashtray fire can lead to personal injury or damage to your vehicle or other property.

The portable ashtray can be placed in the cupholders.

To open the ashtray, gently lift the lid of the ashtray. After using, close the lid firmly.

To empty the ashtray for cleaning, slightly rotate the upper part of the ashtray anticlockwise and remove it.

Warning Lights, Gauges, and Indicators

Speedometer

<Type 1>



<Type 2>



Indicates vehicle speed.

Mileometer

<Type 1>



<Type 2>



The odometer shows how far your car has been driven in kilometres or miles.

There are two independent trip odometers, which measure the distances your vehicle has travelled since you last reset this function.

- **Type 1:** The odometer, trip A and trip B can be switched by pressing the TRIP button.
- **Type 2 :** Press MENU until the upper display area flashes. The odometer, trip A and trip B can

be switched by pressing the up/down Δ or ∇ buttons on the right side of the instrument cluster.

Note: To reset each trip odometer to zero, press the TRIP button of the cluster more than 2 seconds.

Rev Counter

<Type 1>



<Type 2>

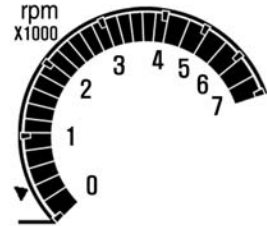

Displays the engine revolutions per minute.

Drive in a low engine speed range for each gear as much as possible.

Fuel Gauge

<Type 1>



<Type 2>

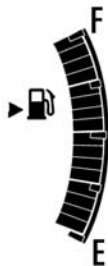

Displays the fuel level in the tank.

Never run the tank dry.

Because of the fuel remaining in the tank, the top-up quantity may be less than the specified tank capacity.

Movement of the fuel within the fuel tank causes the fuel gauge pointer to move when you brake, accelerate or turn.

 **Danger**

Before refuelling, stop vehicle and switch off the engine.

Control Indicators

Control indicators

The control indicators described are not present in all vehicles. The description applies to all instrument versions. When the ignition is switched on, most control indicators will illuminate briefly as a functionality test.

The control indicator colours mean:

red : danger, important reminder

yellow : warning, information, fault

green : confirmation of activation

blue : confirmation of activation



Control indicators in the instrument cluster (Type 1)

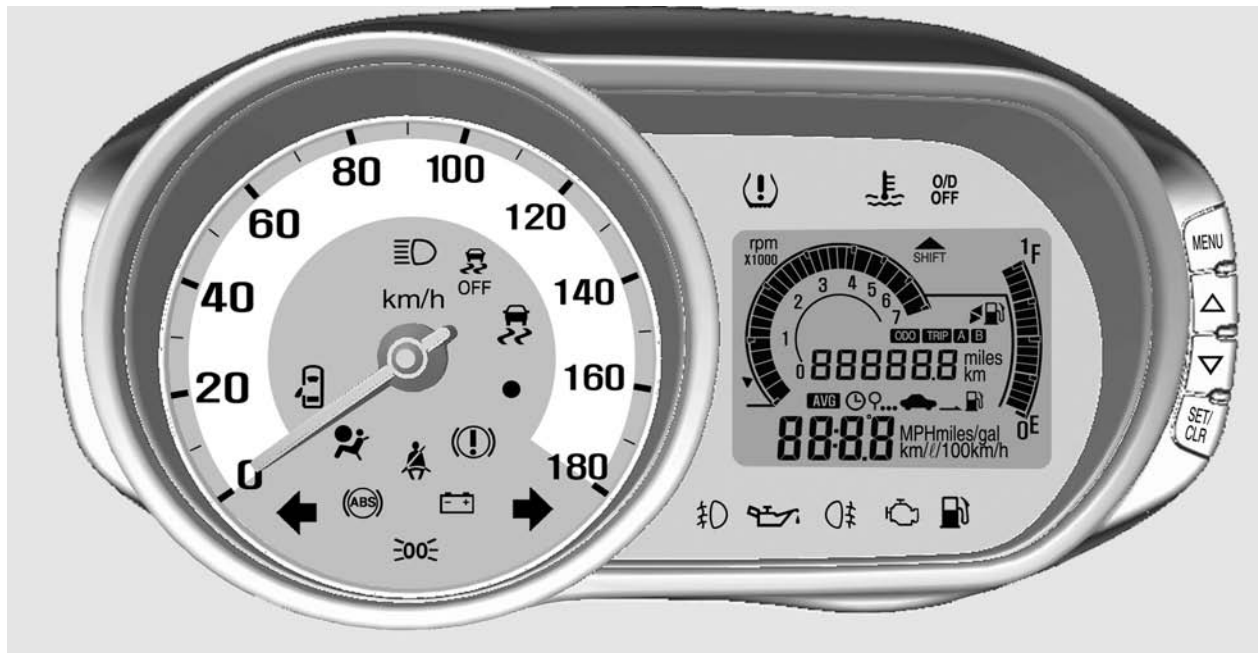

Control indicators in the instrument cluster (Type 2)

Control indicators in the centre console



Transmission Display

Transmission display (Type 1)

A/T illuminates red.

When the ignition is switched on, it illuminates for approximately 3 seconds and should go out, to confirm that the automatic transmission is operational.

⚠ Caution

If it does not come on, or if it does not go out after about 3 seconds, or if it comes on while driving, it means that there is a malfunction in the system.

Vehicle should be taken to an authorised repairer as soon as possible.

Indicator

↔ flashes green.

Flashes

The control indicator flashes if an indicator or the hazard lights are activated.

Rapid flashing: failure of an indicator light or associated fuse.

Bulb replacement → *Headlights on page 10-19*

Fuses → *Fuses on page 10-24*

Indicators → *Indicator Signals on page 6-4*

Seat Belt Reminders

Seat belt reminder on front seats

🚗 for driver's seat illuminates or flashes red.

🚗₂ for front passenger seat illuminates or flashes red, when seat is occupied.

1. After the ignition has been switched ON, the control indicator illuminates until the seat belt is fastened.
2. After the engine is running, the control indicator flashes for 100 seconds and then illuminates until the seat belt is fastened.
3. If the vehicle moves more than 250 m (0.15 mile) or the speed is over 22 km/h (14 mph) with

5-16 Instruments and Controls

unfastened seat belt, the control indicator will flash and the chime will sound for 100 seconds.

After 100 seconds, the indicator will illuminate until the seat belt is fastened, and the chime will go off.

Seat belt status on rear seats

 for rear seats illuminates or flashes red.

1. When engine is running with all doors closed and the vehicle speed is less than 10 km/h (6 mph), the rear seat belt indicators illuminate until the belts are fastened. In case that nobody occupies on the seats, this behaviour is still applied.
2. If the vehicle speed is over 10 km/h (6 mph) with all doors closed, unfastened rear seat belt indicators will illuminate for 35 seconds and go off regardless of occupancy of the rear seats. If a rear seat belt becomes fastened, the other

unfastened belt indicator will illuminate again for 35 seconds and go off.

3. If any rear seat belt status changes from fastened to unfastened when the vehicle speed is over 10 km/h (6 mph) and all doors closed, the belt indicator will flash until the seat belt is fastened and a chime will sound 4 times.

Three-point seat belt ⇨ *Three-Point Seat belt on page 3-8*

Airbag and Safety Belt Tensioner Light

 illuminates red.

When the ignition is switched on, the control indicator illuminates for a few seconds. If it does not illuminate, does not go out after a few seconds or illuminates whilst driving, there is a fault in the airbag system. Seek the assistance of a workshop. The systems may fail to trigger in the event of an accident.

Vehicle trouble or deployment of the belt pretensioners or airbags is indicated by continuous illumination of .

Warning

Have the cause of the fault remedied immediately by a workshop.

Belt pretensioners, airbag system ⇨ *Front Airbag System on page 3-12*

Airbag On-Off Light

ON  illuminates yellow.

When the control indicator illuminates the front passenger airbag is activated.

OFF  illuminates yellow.

When the control indicator illuminates the front passenger airbag is deactivated.

Airbag deactivation ⇨ *Airbag On-Off Switch on page 3-16*

Charging System Light

 illuminates red.

It illuminates when the ignition is switched on and goes out shortly after the engine starts.

Illuminates when the engine is running

Stop, switch off engine. Battery is not charging. Engine cooling may be interrupted. Seek the assistance of a workshop.

Malfunction Indicator Lamp

 illuminates or flashes yellow.

It illuminates when the ignition is switched on and goes out shortly after the engine starts.

Brake System Warning Light

 illuminates red (Type 1).

 illuminates red (Type 2).

Illuminates when the parking brake is released, if the brake and clutch fluid level is too low or if there is a brake system fault. Brake fluid ⇨ *Brake Fluid on page 10-15*

Warning

Do not drive with the brake system warning light on.

This may mean your brakes are not working properly.

Driving with malfunctioning brakes can lead to a collision resulting in personal injuries and damage to your vehicle and other property.

Illuminates after the ignition is switched on if the manual parking brake is applied. Parking brake ⇨ *Parking Brake on page 9-12*

Antilock Brake System (ABS) Warning Light

 illuminates yellow.

Illuminates for a few seconds after the ignition is switched on. The system is ready for operation when the control indicator goes out.

If the control indicator does not go out after a few seconds, or if it illuminates while driving, there is a fault in the ABS. The brake system remains operational but without ABS regulation.

Antilock brake system ⇨ *Antilock Brake System (ABS) on page 9-11*

Up-Shift Light

 illuminates when to shift to the next higher gear for best fuel economy.

Overdrive Off Light

 illuminates yellow.

This indicator comes on when the overdrive function is cancelled.

Pressing the overdrive button on the side of the selector lever knob again will make the overdrive OFF indicator go off and activate the overdrive function.

Electronic Stability Control (ESC) Indicator Light

 illuminates or flashes yellow.

Illuminates

A fault in the system is present. Continued driving is possible. Driving stability, however, may deteriorate depending on road surface conditions.

Have the cause of the fault remedied by a workshop.

Flashes

The system is actively engaged. Engine output may be reduced and the vehicle may be braked automatically to a small degree.

Electronic Stability Control 
Electronic Stability Control (ESC) on page 9-13

Electronic Stability Control (ESC) Off Light

 flashes yellow.

The system is deactivated.

Engine Coolant Temperature Warning Light

 illuminates red.

This light tells you that the engine coolant has overheated.

If you have been operating your vehicle under normal driving conditions, you should pull off the road, stop your vehicle and let the engine idle for a few minutes.



If the light does not go out, you should switch the engine off and consult a workshop as soon as possible. We recommend that you consult your authorised workshop.

Tyre Pressure Monitoring System Light

 illuminates yellow.

It illuminates when the ignition is switched on and goes out shortly after the engine starts.

If  comes on while driving, the tyre pressure monitoring system detects that one or more of your tyres is significantly under-inflated. Stop the vehicle in a safe place, check tyres and inflate the tyres to the recommended pressure on the tyre inflation pressure label.

When the system detects a malfunction,  flashes for about one minute and then stays on for the remainder of the ignition cycle.  comes on until the problem is corrected. Have the vehicle checked by a workshop.

Engine Oil Pressure Light

 illuminates red.

It illuminates when the ignition is switched on and goes out shortly after the engine starts.

Illuminates when the engine is running

Caution

Engine lubrication may be interrupted. This may result in damage to the engine and/or locking of the drive wheels.

If the engine oil pressure warning light comes on while driving, Pull off the road, stop the engine and check the oil level.

Warning

When the engine is off, considerably more force is needed to brake and steer.

Do not remove key until vehicle is stationary, otherwise the steering wheel lock could engage unexpectedly.

Check oil level before seeking the assistance of a workshop. Engine oil  *Engine Oil on page 10-9.*

Low Fuel Warning Light

 illuminates yellow.

Illuminates when level in fuel tank is too low.

Caution

Do not let your vehicle run out of fuel.

This can damage the catalytic converter.

Catalytic converter  *Catalytic Converter on page 9-4*

Main-Beam On Light

 illuminates blue.

Illuminated when main beam is on and during headlight flash.

Main beam /dipped beam  *Headlamp Main/Dipped-Beam Changer on page 6-1*

Front Fog Lamp Light

 illuminates green.

Illuminated when the front fog lights are on  *Front Fog Lamps on page 6-4*

Rear Fog Lamp Light

 illuminates yellow.

Illuminated when the rear fog light is on → *Rear Fog Lamps on page 6-4*

Door Ajar Light

 illuminates red (Type 1).

 illuminates red (Type 2).

It illuminates when a door or the tailgate is open.

Trip Computer



<Type 1>



<Type 2>



The trip computer provides the driver with driving information such as driving distance for remaining fuel, ambient temperature, average speed, and driving time.

- **Type 1:** Each time you press the MODE button of the cluster.
- **Type 2:** Press MENU until the lower display area flashes. Use  or  to scroll through the menu items.

Driving distance for remaining fuel



This mode indicates the estimated driving distance to empty from the current fuel in the fuel tank.

The distance range is 50~999 km (31~620 miles).

The trip computer is able to register the refilled fuel of at least 4 litres or more.

If you fill the vehicle with fuel when the vehicle is on an incline or the battery is disconnected, the trip computer will not be able to read the actual value.

When the driving distance for remaining fuel is less than 50km (31 mile), "—" will be displayed and flashed.

The distance can be different depending on driving patterns.

Note: As an auxiliary device, the trip computer may have differences with the actual distance for remaining fuel according to circumstances.

The driving distance for remaining fuel can be changed by the driver, the road and the vehicle speed because it is calculated according to the changing fuel efficiency.

Average speed

<Type 1>



5-22 Instruments and Controls

<Type 2>



This mode indicates the average speed.

The average speed is accumulated while the engine is running even if the vehicle is not driven.

The average speed range is 0~180 km/h (0~111 mph).

To reset the average speed to zero:

- **Type 1:** press the MODE button for more than 1 second.

- **Type 2:** Press the SET/CLR button for more than 1 second.

Driving time



This mode indicates the total driving time.

To reset the driving time to zero:

- **Type 1:** Press the MODE button for more than 1 second.
- **Type 2:** Press the SET/CLR button for more than 1 second.

The driving time is accumulated while the engine is running even if the vehicle is not driven.

The driving time will be initialised to 0:00 after being displayed to 99:59.

Ambient temperature

<Type 1>



<Type 2>

18°C

Show the outside temperature.

Note: The driving distance for remaining fuel, average speed and ambient temperature can differ from the actual distance according to driving conditions, driving pattern or vehicle speed.

Vehicle Personalisation



The vehicle can be personalised by changing the settings in the Info display.

Depending on vehicle equipment some of the functions described below might not be available.

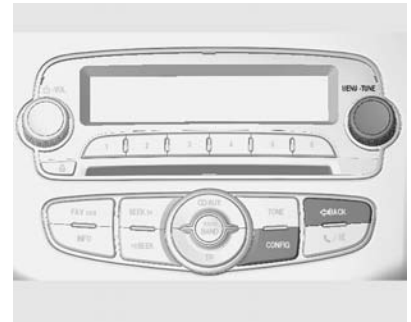

Press the CONFIG button, when ignition is ON and the infotainment system is activated.

Setting menus are displayed. To switch the setting menu, turn the MENU knob.

To select a setting menu, press the MENU button.

To close or to go back to previous, press the BACK button.

The following menus can be displayed:

- Languages

5-24 Instruments and Controls

- Time Date
- Radio Settings
- Restore factory Settings

Language Settings

Change the languages.

Time and Date Settings

Infotainment system ⇨

Radio Settings

Infotainment system ⇨

Restore factory Settings

All settings are restored to initial settings.

Lighting

Exterior Lighting

Exterior Lamp Controls	6-1
Headlamp Main/Dipped-Beam Changer	6-1
Flash-to-Pass	6-2
Headlamp Range Adjustment	6-2
Headlights When Driving Abroad	6-3
Daytime Running Lamps (DRL)	6-3
Hazard Lights	6-3
Turn and Lane-Change Signals	6-4
Front Fog Lamps	6-4
Rear Fog Lamps	6-4
Reversing Lamps	6-4

Interior Lighting

Interior Lamps	6-5
----------------------	-----

Lighting Features

Battery Power Protection	6-5
--------------------------------	-----

Exterior Lighting

Exterior Lamp Controls



To turn the head and tail lights on or off, twist the end of the combination switch lever. The light switch has three positions which activate various light functions as follows:

OFF : All the lights are off.

 : The tail lights, number plate lights and instrument panel lights are illuminated.

 : The dipped beam headlights and all of the above lights are illuminated.

The headlights will turn off automatically when the driver's door is opened after the ignition switch is turned to LOCK.

Headlamp Main/ Dipped-Beam Changer



To switch from low to main beam, push lever.

6-2 Lighting

To switch to dipped beam, push lever again or pull.

Note: The headlight main beam indicator illuminates when the headlights are on main beam.

Warning

Always switch the main beam headlights to dipped beam when you approach oncoming vehicles or other vehicles ahead. Main beam headlights can temporarily dazzle other drivers, which could result in a collision.

Flash-to-Pass



The lever will return to its normal position when you release it. The main beam headlights will stay on as long as you hold the combination switch lever toward you.

Headlamp Range Adjustment





To adapt headlight range to the vehicle load to prevent dazzling: turn knob  to required position.

- 0:** front seats occupied
- 1:** all seats occupied
- 2:** all seats occupied and load compartment laden
- 3:** driver's seat occupied and load compartment laden

Headlights When Driving Abroad

The asymmetrical headlight beam extends visibility at the edge of the road at the passenger side.

However, when driving in countries where traffic drives on the opposite side of the road, adjust the headlights to prevent dazzling of oncoming traffic.

Have the headlights adjusted by a workshop.

Daytime Running Lamps (DRL)

Daytime running light increases visibility of the vehicle in the daytime.

Tail lights are not on.

Hazard Lights

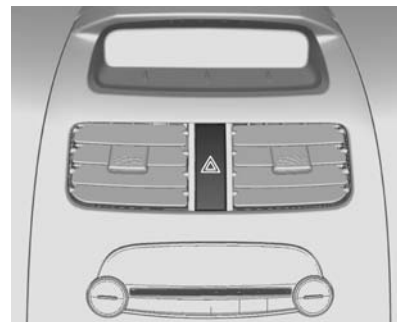

Operated with the  button.

To activate the hazard lights, push the button.

To turn off the hazard lights, push the button again.

6-4 Lighting

Turn and Lane-Change Signals

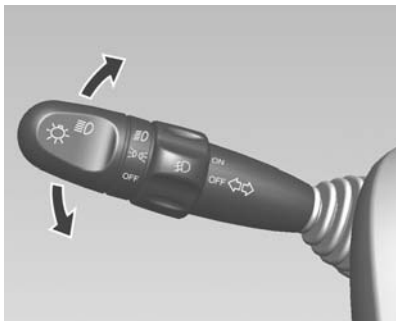

lever up: right indicator

lever down: left indicator

If the lever is moved past the resistance point, the indicator is switched on constantly. When the steering wheel moves back, the indicator is automatically deactivated.

Front Fog Lamps

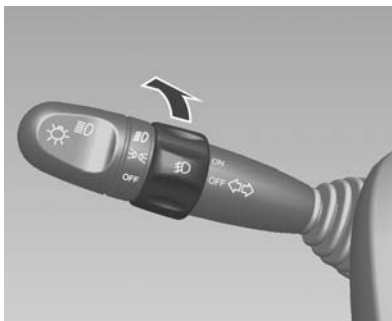

To turn on the fog lights, make sure the dipped beam headlights are on.

Turn the ring on the middle of the combination switch lever to ON. To turn off the fog lights, turn the ring to the OFF position.

Rear Fog Lamps



To turn on the rear fog light, twist the end of the windscreen wiper lever when the dipped beam headlights are on.

To turn off the rear fog light, twist the end of the lever again.

Reversing Lamps

The reversing light illuminates when the ignition is on and reverse gear is selected.

Interior Lighting

Interior Lamps

Interior lights



Courtesy light

Operate rocker switch:

○ : always off until shut off manually.

☐ : automatic switching on when you open a door and off after doors are closed.

◻ : always on, even when doors are open.

Note: The battery can be discharged if the lights stay on for a long time.

Warning

Avoid using the courtesy light while driving in the dark.

A lit passenger compartment reduces visibility in the dark, and could cause a collision.

Lighting Features

Battery Power Protection

Switching off electric lights

To prevent the battery from being discharged, some lights are turned off automatically if you open the driver's door when the ignition is switched to LOCK or ACC.

The courtesy lights will not be applied with this function.

Infotainment System

Introduction

Introduction	7-1
Overview	7-3
Operation	7-7

Radio

AM-FM Radio (and DAB (only for Type A))	7-11
Fixed Mast Aerial	7-22

Audio Players

CD Player	7-23
Auxiliary Devices	7-32

Personalisation

Personalisation	7-40
-----------------------	------

Phone

Bluetooth	7-44
Hands-Free Phone	7-49

Introduction

General Information

The Infotainment system provides Infotainment in your car, using the latest technology.

The radio can be easily used by registering up to 36 AM/FM radio or DAB (only for Type A) stations with the **PRESET [1] ~ [6]** buttons per every six pages.

The integrated CD player can play audio CD and MP3 (WMA) discs, and the USB player can play connected USB storage devices or iPod products

The Bluetooth phone connection function allows for the use of wireless hands-free phone calls, as well as a phone music player.

Connect a portable music player to the exterior sound input to and enjoy the rich sound of the Infotainment system.

The digital sound processor provides a number of preset equaliser modes for sound optimisation.

- Maximum output power: 25 W x 4 channels
- Speaker impedance: 4 ohms

The system can be easily adjusted using the carefully designed adjusting device, smart display, and multifunctional menu dial regulator.

- The "Overview" section provides a simple overview of Infotainment system's functions and summary of all regulatory devices.
- The "Operation" section explains the basic controls for the Infotainment system.

7-2 Infotainment System

Screen Display

[Start-up Screen]



[Radio Screen]

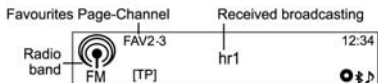

[Setup Menu Screen]

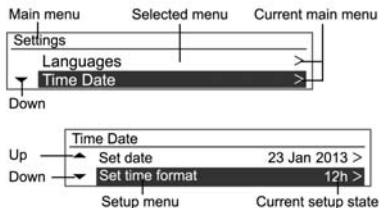

The screen display may differ from the manual display since most screen displays differ according to the device's set-up and vehicle specification.

Overview

Type A: Radio/DAB + CD/MP3 + USB/iPod + AUX + BT

Type B: Radio + CD/MP3 + USB/iPod + AUX + BT

7-4 Infotainment System



1. **Display**

Display for Play/Reception/Menu state and information.

2. **POWER**  button with **VOLUME** dial

- Turn the power on/off by pressing this button.
- Turn the dial to adjust the overall volume.

3. **PRESET [1] ~ [6]** buttons

- Hold down any of these buttons to add the current radio station to the current Favourites page.
- Press any of these buttons to select the channel linked to that button.

4. **EJECT**  button

Press this button and take out the disc.

5. **Disc slot**

This is the slot in which compact discs are inserted or ejected.

6. **FAVOURITE [FAV1-2-3]** button

Press this button to select the page of saved favourites channels.

7. **INFORMATION [INFO]** button

- Press this button to view file information when using the CD/MP3 or USB/iPod play modes.
- View information about a radio station and the currently playing song when using the radio function.

8.  **SEEK**  buttons

- Press these buttons while using radio or DAB (Digital Audio Broadcasting: only for Type A) automatically seek stations with clear reception. You can manually set the broadcasting frequency by holding down these buttons.

- Press these buttons while using the CD/ MP3 or USB/ iPod audio modes to instantly play the previous or next track.
- You can hold down these buttons to quickly rewind/ forward through the currently playing songs.

9. **CD/AUX** button

Press button to select CD/MP3, USB/iPod or AUX audio function.

10. **RADIO BAND** button

Press button to select AM/FM radio or DAB (Digital Audio Broadcasting: only for Type A) function.

11. **TP** button

While using the FM RDS function, turn the TP (Traffic Programme) function on or off.

12. **CONFIG** button

Press this button to enter the system set-up menu.

7-6 Infotainment System

13. **TONE** button

Press this button to adjust/
select the sound set-up mode.

14. **MENU** button with **TUNE** dial

- Press this button to display the currently functioning menu or select/practice set-up content and set-up values.
- Turn the dial to move/change set-up content or set-up values.

15. ↶ **BACK** button

Cancel input content or return to the previous menu.

16. **PHONE** [📞] / **MUTE** [🔇] button

- Press this button to activate Bluetooth mode/make a call.
- Hold down the button to turn the mute function on or off.

Steering wheel audio control: option

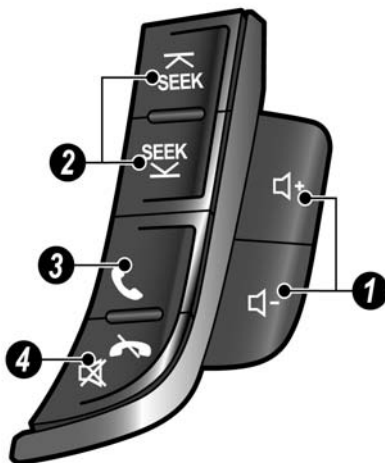

1. **Volume** [🔊] +/- buttons

- Press the buttons to increase/decrease the volume step.
- Hold down the buttons to quickly up/down the volume level.

2. ↶ **SEEK** ↷ buttons

- Press the button to change the registered radio stations or the music track being played.
- Hold down the button to change the favourite station or rewind/forward through the currently playing songs.

3. **Call** [📞] button

Press this button to make a call.

4. **Hang up** [📞] / **MUTE** [🔇] button

- Press this button to end a call.

- Hold down the button in any music play mode to turn the mute function on/off.

Operation

Buttons and controlling device

The Infotainment system is operated by using the function buttons, multifunctional dial, and the menu indicated on the screen display.

The buttons and control devices used in the system are as follows.

- The Infotainment system buttons and dial
- Steering wheel audio control buttons

System on/off



Press the **POWER** [⏻] button to turn the power on.

- Turning on the power will play the previously chosen broadcasting station or song.

Press the **POWER** [⏻] button to turn the power off.

Volume control

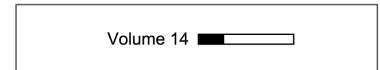

Turn the **VOLUME** [VOL] dial to adjust the volume.

- The current sound volume is indicated.
- Turning on the Infotainment system power will set the volume level to its previous selection (when it is less than the maximum starting volume).

7-8 Infotainment System

Volume limit by high temperature

If the inside temperature of the radio is very high, the Infotainment system will limit the controllable maximum volume.

If necessary, the volume will automatically decrease.

Tone settings

From Tone Settings menu, sound features can be set-up differently according to the AM/FM radio or DAB (only for Type A) and each audio player's functions.

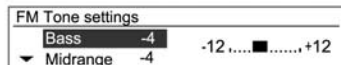

Press the **TONE** button when using the relevant functioning mode.

Turn the **TUNE** dial to select desired tone control mode, and then press the **MENU** button.



Turn the **TUNE** dial to select the desired tone control value, and then press the **MENU** button.

It is possible to initialise the currently selected item by long-pressing the **MENU** button in the tune configuration mode, or to initialise all items of the tune configuration mode by long-pressing the **TONE** button.





Tone Settings menu





- Bass: Adjust the bass level from -12 to +12.

- Midrange: Adjust the midrange level from -12 to +12.
- Treble: Adjust the treble level from -12 to +12.
- Fader: Adjust the front/rear speaker balance from front 15 to rear 15 in the six speaker system model.
- Balance: Adjust the left/right speaker balance from left 15 to right 15.
- EQ (Equaliser): Select or turn off the sound style (OFF ↔ Pop ↔ Rock ↔ Classical ↔ Talk ↔ Country)

Select function

AM/FM radio or DAB (only for Type A)









RDS station TP on TP station		FAV2-3 RDS Planet R	12:34
	FM [TP]		
RDS off TP off Non-TP		FAV2-3 101.1 MHz	12:34
	FM		

DAB-FM Service Linking		FAV1 11B xDASDING SWR Test	12:34
	DAB [TP]		
Conditional Access		FAV1 SA ServiceName Conditional Access	12:34
	DAB+FM [TP]		

Press the **RADIO BAND** button to select AM/FM radio or DAB (only for Type A) function.

Press the **MENU** button to open the AM/FM or DAB menu that includes options for selecting broadcast stations.

CD/MP3/USB/iPod audio or exterior sound input (AUX) play

MP3 CD		Bare ladies Breakout Track 1	12:34 0:02
	MP3 [TP]		
USB		Bare ladies Breakout Track 1	12:34 0:02
	MP3 [TP]		
iPod		The Eagles Life in the Fast Lane Track 1	12:34 0:02
	iPod [TP]		
AUX		AUX	12:34
	AUX [TP]		

Repeatedly press **CD/AUX** button to toggle through the audio player functions, the CD function for CD/MP3 discs, or the connected AUX/USB/iPod audio player. (CD/MP3 → AUX → USB/ iPod → CD/MP3 →)

7-10 Infotainment System



Press the **MENU** button to open the menu with options for the relevant function or the menu of the relevant device.

Bluetooth hands-free phone device



Press the **PHONE** [📞] button to select the Bluetooth hands-free phone function.

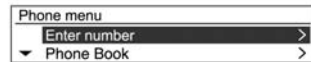

Press the **MENU** button to open Bluetooth with options for the relevant function.

Radio

AM-FM Radio (and DAB (only for Type A))

Before using AM/FM Radio and DAB

- (10) **RADIO BAND** button
Press button to select AM/FM radio or DAB (Digital Audio Broadcasting: only for Type A) function
- (14) **MENU** button with **TUNE** dial
 - Turn this dial to manually find a broadcasting frequency.
 - Press this button to access the menu screen from the current mode.
- (16) ↶ **BACK** button
Cancel the input item or return to the previous screen/menu.

- (8) ⏪ **SEEK** ⏩ buttons
 - Press this button to automatically search for available radio or DAB (Digital Audio Broadcasting: only for Type A) stations.
 - Hold down this button to change the radio or DAB (only for Type A) frequency as desired, and then let the button go to stop at the current frequency.
- (6) **FAVOURITE [FAV1-2-3]** button
Press this button to move through the pages of saved favourite radio or DAB (only for Type A) stations.

- (3) **PRESET [1] ~ [6]** buttons
 - Hold down any of these **PRESET** buttons to register the current radio or DAB (only for Type A) station to that button.
 - Press this button to select the station registered to the **PRESET** button.
- (11) **TP** button
While using the FM RDS function, turn the TP (Traffic Programme) function on or off.
- (7) **INFORMATION [INFO]** button
View the information for broadcast radio or DAB (only for Type A) stations.
- (16) **MUTE [M]** button
Hold down the button to turn the mute function on or off.

7-12 Infotainment System

Listening to radio or DAB (only for Type A) station

Selecting the radio or DAB mode

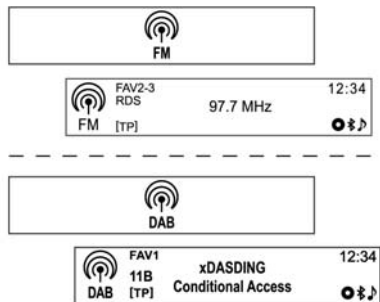

Repeatedly press the **RADIO BAND** button to select the AM/FM radio or DAB band.

- The previously chosen broadcasting station will be received.

Searching for radio station automatically

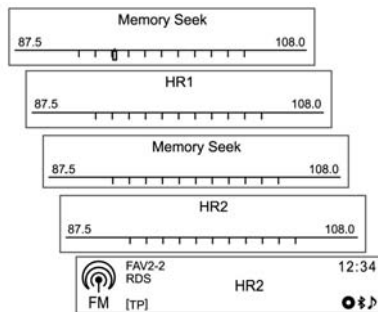

Press the **SEEK** buttons to automatically search for available radio stations with good reception.

Seeking for DAB service component automatically (only for Type A)



Press the **SEEK** buttons to automatically seek for available DAB service component in current ensemble.

To skip to the previous/next ensemble, press the **SEEK** buttons.

Seeking for radio station

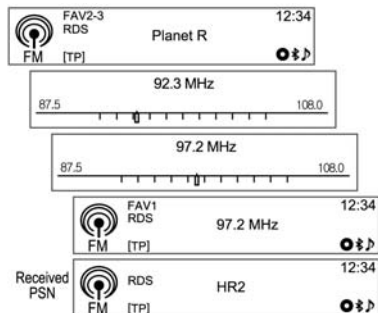

Hold down the **SEEK** buttons to quickly change the frequency, and then release the button at the desired frequency.

Seeking for DAB ensemble (only for Type A)

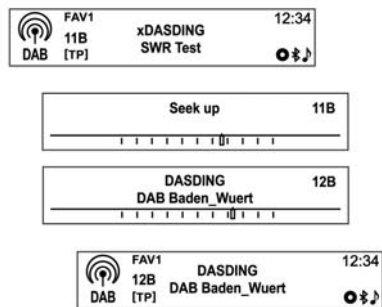

Press and hold the **SEEK** buttons to automatically seek for available DAB service component with good reception.

Linking the DAB service (only for Type A)

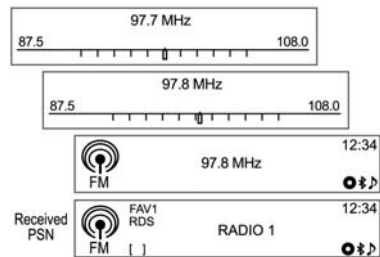

[DAB-DAB on/DAB-FM off]

7-14 Infotainment System

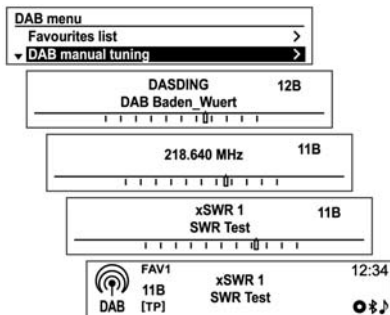

[DAB-DAB off/DAB-FM on]

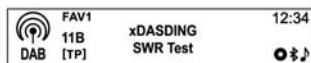

[DAB-DAB on/DAB-FM on]

When you set-up the Auto linking DAB-FM is activated, if the DAB service signal is weak, the infotainment system received the linked service component automatically. [refer to Settings (press the **CONFIG** button) → Radio settings → DAB settings → Auto linking DAB-FM]

Tuning a radio station manually

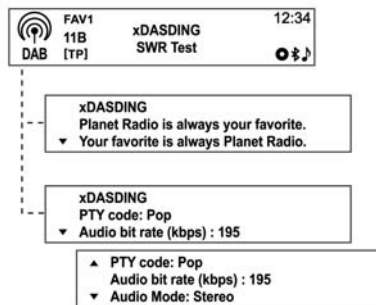

Turn the **TUNE** dial to manually find the desired broadcasting frequency.

Tuning a DAB station manually (only for Type A)



From the DAB mode, press the **MENU** button to enter the DAB menu.

Turn the **TUNE** dial to select the DAB manual tuning, and then press **MENU** button.

Turn the **TUNE** dial to manually find the desired broadcasting frequency, and then press **MENU** button.

Using the DAB stations list (only for Type A)

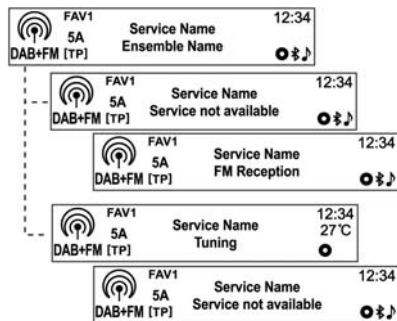

Turn the **TUNE** dial to show the DAB stations list.

- The Station list information will be displayed.
- If the stations list is empty, DAB stations list updating is started automatically.

Turn the **TUNE** dial to select the desired list, and then press the **MENU** button to receive the relevant broadcasting channel.

Showing the DAB information (only for Type A)

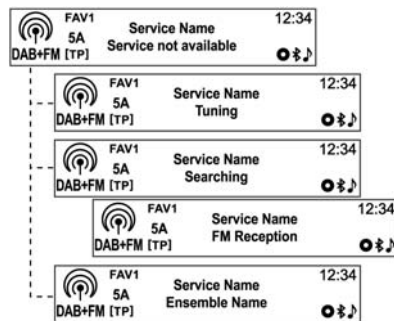

Repeatedly press **INFORMATION [INFO]** button to select the desired display mode for DAB station information.

Using the PRESET buttons

Registering PRESET button

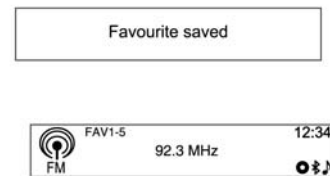

Press **FAVOURITE [FAV1-2-3]** button to select the desired page of saved favourites.

Hold down any of **PRESET [1] ~ [6]** buttons to register the current radio or DAB station (only for Type A) to that button of the selected Favourites Page.

- Up to Favourites pages can be saved, and each page can store up to six radio or DAB stations.

7-16 Infotainment System

- It is possible to set-up the number of the Favourites pages being used in "Settings → Radio settings → Radio favourites (Max. number of favourite pages)".
- If a new radio station is registered to a **PRESET [1] ~ [6]** previously registered button, its previous content will be deleted and be replaced with the new radio or DAB station that is saved.

Listening to PRESET button directly

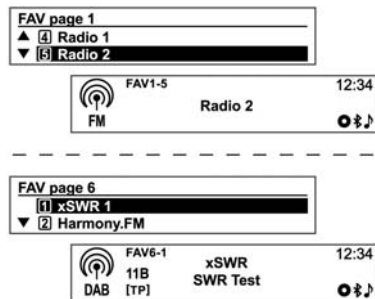

Repeatedly press the **FAVOURITE [FAV1-2-3]** button to select the desired FAV (Favourites) Presets Page.

- The number 1 broadcasting information of the selected FAV (Favourites) Presets Page will be displayed.

Press a **PRESET [1] ~ [6]** buttons to directly listen to the radio or DAB station (only for Type A) saved to that button.

Using the radio or DAB (only for Type A) menu

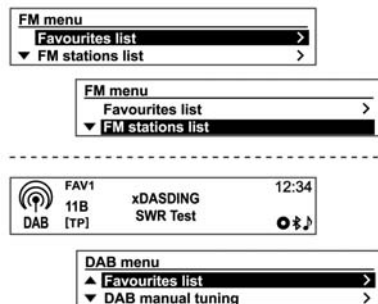

Press the **MENU** button to display the radio or DAB menu.

Turn the **TUNE** dial to move to the desired menu item, and then press **MENU** button to select the relevant item or to display the item's detailed menu.

AM/FM or DAB (only for Type A) menu → Favourites list

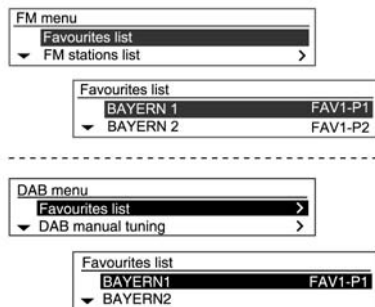

From the AM/FM or DAB menu, turn the **TUNE** dial to select the Favourites List, and then press **MENU** button.

- The Favourites list information will be displayed.

Turn the **TUNE** dial to select the desired Favourites list, and then press **MENU** button to receive relevant broadcasting channel.

AM/FM Menu → AM/FM stations list

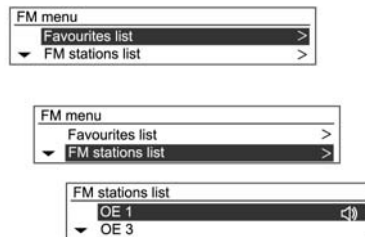

From the AM/FM Menu, turn the **TUNE** dial to select the FM/AM stations list, and then press **MENU** button.

- The station list information will be displayed.

Turn the **TUNE** dial to select the desired list, and then press the **MENU** button to receive the relevant broadcasting channel.

FM or DAB(only for Type A) menu → FM or DAB category list

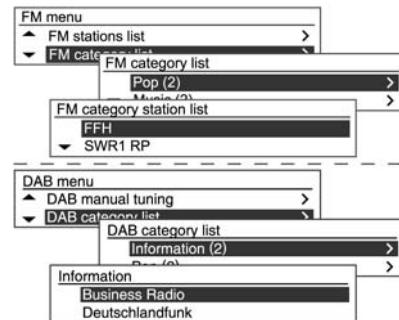

From the FM or DAB menu, turn the **TUNE** dial to select the FM or DAB category list, and then press the **MENU** button.

- The FM or DAB category list will be displayed.

Turn the **TUNE** dial to select the desired list, and then press the **MENU** button to receive the relevant broadcasting frequency.

7-18 Infotainment System

DAB menu → DAB announcements (only for Type A)

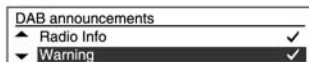
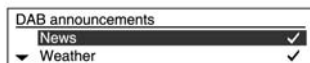

From the DAB menu, turn the **TUNE** dial and move to the DAB announcements, and then press **MENU** button.

- The DAB announcement list will be displayed.

Turn the **TUNE** dial to select the desired lists, and then press the **MENU** button to receive the relevant broadcasting frequency.

AM/FM or DAB (only for Type A) menu → Update AM/FM or DAB stations list



From the AM/FM or DAB menu, turn the **TUNE** dial and move to the Update AM/FM or DAB stations list, and then press **MENU** button.

- The FM/AM/DAB broadcasting list update will proceed.
- During the AM/FM/DAB broadcasting list update, press the **MENU** button or the **BACK** button to stop it from saving changes.

RDS (Radio Broadcast Data System)

The Radio Data System (RDS) is a service by FM stations that considerably makes it easier to find radio stations with fault-free reception.



- RDS stations are indicated by the programme name with the broadcasting frequency.

View RDS broadcasting information

While receiving RDS broadcasting, press the **INFORMATION [INFO]** button to check RDS broadcasting information that is being received.

Configuring RDS

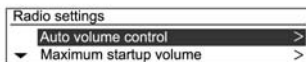

Press the **CONFIG** button to display system Settings menu.

Turn the **TUNE** dial to move to the Radio settings, and then press the **MENU** button.

Turn the **TUNE** dial to select RDS options, and then press the **MENU** button.

Switching RDS On and Off

Set the option RDS to On or Off.

The following advantages result through activating RDS:

- On the display the programme name of the set station appears instead of its frequency.
- The Infotainment system always tunes into the best receivable broadcasting frequency of the set station by means of AF (Alternative Frequency).



From the RDS options menu, turn the **TUNE** dial to move to RDS Off, and then press the **MENU** button to turn On the RDS function.

Switching Regionalisation On and Off

RDS must be activated for regionalisation.

At certain times some RDS stations broadcast regionally different programmes on different frequencies.

Set the option Regional (REG) to On or Off.

7-20 Infotainment System

Only alternative frequencies (AF) with the same regional programmes are selected.

If regionalisation is switched off, alternative frequencies of the stations are selected without regard to regional programmes.



From the RDS options menu, turn the **TUNE** dial to move to Regional Off, and then press the **MENU** button to turn On the Regional function.

Switching the Text scroll freeze On and Off

To switch the Text scroll freeze function (for displaying the information of programme service) On or Off.



From the RDS options menu, turn the **TUNE** dial to move to Text scroll freeze Off, and then press the **MENU** button to turn on the Text scroll freeze function (On).

Volume of the traffic announcements (TA)

The minimum volume of the traffic announcements (TA) can be preset.

The minimum volume of the traffic announcements can be increased or reduced in comparison to the normal audio volume.

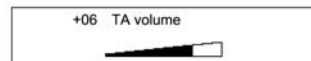
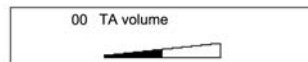

From the RDS options menu, turn the **TUNE** dial to move to TA volume, and then press the **MENU** button.

Turn the **TUNE** dial to adjust the TA volume level, and then press the **MENU** button.

Radio traffic service (TP = Traffic Programme)

Radio traffic service stations are RDS stations that broadcast traffic news.

Switching the Traffic Announcement standby facility of the infotainment system On and Off:



Press the **TP** button to turn the Traffic programme service function activate or deactivate.

- If the radio traffic service is switched on, then [] is displayed in the radio main menu.

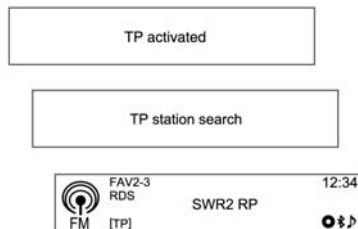

- If the current station is not a radio traffic service station, then a search is automatically started for the next radio traffic service station.

- Once a radio traffic service station has been found, [TP] is displayed in the radio main menu.
- If the radio traffic service is switched on, then CD/MP3/USB/iPod music or AUX replay is interrupted for the duration of the traffic announcement.

Blocking out traffic announcements

To block out a traffic announcement, e.g. during CD/MP3 replay or radio reception:

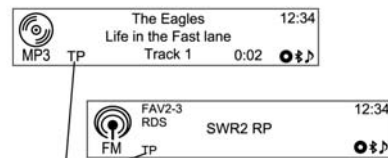

Blocking out status indicator : [TP] → TP

7-22 Infotainment System

Press the **TP** button.

Switch on the radio traffic service and fully turn down the volume of the Infotainment system.

- The traffic announcement is aborted, but the radio traffic service remains switched on.

Blocking out current traffic announcements

To block out a current traffic announcement e.g. during TA radio reception:



Press the **TP** button.

Fixed Mast Aerial

Only for Type A

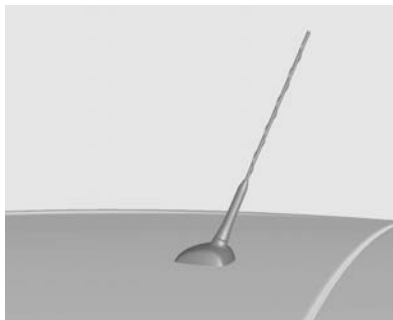

Only for Type B

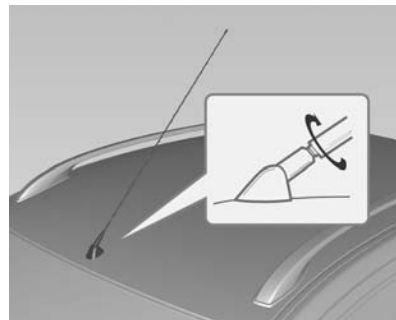

To remove the roof aerial, rotate it anticlockwise. To install the roof aerial, rotate it clockwise.

Caution

Be sure to remove the aerial before entering a place with a low ceiling or it may be damaged.

Entering the automatic car wash with the aerial installed may result in damage to the aerial or the roof

(Continued)

Caution (Continued)

panel. Be sure to remove your aerial before entering the automatic car wash.

Install the aerial fully tightened and adjusted to the upright position to ensure proper reception.

Audio Players

CD Player

The CD/MP3 player of this system can play audio CD and MP3 (WMA) discs.

Before using CD player

Important information about audio CD and MP3 (WMA) discs

 **Caution**

In any case, do not insert any DVDs, mini discs with a diameter of 8cm, or discs with abnormal surfaces in this CD/MP3 (WMA) player.

Do not put any stickers on the disc surface. Such discs may be stuck in the CD player and damage the drive device. If this occurs, then the device will need to be replaced at high cost.

- An audio CD disc with an anti-piracy function with no compatibility with the audio CD standard may not work properly or at all.
- CD-R and CD-RW discs that are manually recorded are easier to be handled with carelessness than the original CD discs.

Manually recorded CD-R and CD-RW discs should especially be handled with care. Please refer to the following.
- Manually recorded CD-R and CD-RW discs may not play properly or at all.

In such cases, this is not a problem with the device.
- When changing discs, take care to not smear any fingerprints on the playing side.
- After removing the disc from the CD/MP3 player, make sure to immediately put the disc into a

7-24 Infotainment System

disc sleeve to prevent it from being damaged or smeared with dust.

- If the disc is smeared with dust or liquid, then this may cause problems by contaminating the lens of the CD/MP3 player inside the device.
- Protect the disc from heat and exposure to direct light.

Usable disc type

- This product can play Audio CD/MP3 (WMA) discs.
 - CD-DA: CD-R/CD-RW
 - MP3 (WMA): CD-R/CD-RW/CD-ROM
- MP3 (WMA) files below cannot be played.
 - File encoded in MP3i (MP3 interactive) or MP3 PRO standards
 - MP3 (WMA) file encoded in non-standards

- MP3 files that are not in MPEG1 Layer3 format

Caution for using disc

- Do not use any of the discs described below. Excessive use of these discs in the player may cause problems.
 - Discs with stickers, labels, or a protective cell attached.
 - Discs affixed with a label printed with an inkjet printer
 - Discs that are made by over-burning, thus holding data exceeding the standard capacity
 - Discs with cracks or scratches or are bent will not be played properly.
 - An 8 cm disc or a non-circular disc (quadrangle, pentagon, oval)
- Do not put anything other than discs in the disc slot since this may cause trouble or damage.

- The disc player may not work properly if the heater is turned on in cold weather due to moisture created inside the device. If this is a concern, keep the product off for about one hour before use.
- Play may be stopped due to the vehicle shaking while driving on rugged roads.
- Do not forcefully take out or insert the disc or block it with your hand while it is being ejected.
- Insert the disc with the printed side facing up. It cannot be played if it is inserted upside down.
- Do not touch the recording side with your hand while handling the disc (the side without any print or decoration).
- Place discs that are not being used in cases, and keep them in a place not exposed to direct light or high temperature.

- Do not smear any chemical substances on the disc. Clean discs of dirt with a moist, soft cloth, wiping from the centre to the edge.

Caution for using CD-R/RW disc

- When using CD-R/CD-RW discs, only the disc that has been "finalised" can be used.
- Discs that are created with a PC may not play according to the application program set-up and environment.
- CD-R/CD-RW discs, especially bulk discs, may not be work if they are directly exposed to direct light or high temperature, or if they are kept inside your car for a long time.
- The title and other text information recorded on CD-R/CD-RW discs may not be displayed on this device.
- CD-RW discs may have longer loading times than CDs or CD-R discs.

- Damaged music files may not be played or will be cut off while playing
- Some anti-piracy discs may not be played.
- An MP3 (WMA) disc can have a maximum of 512 files for each of the 10 folder levels, and a maximum number of 999 files can be played.
- This system can only recognise MP3 (WMA) discs made in ISO-9660 level 1/2 or in the Joliet file system. (It does not support the UDF file system.)
- MP3/WMA files are not compatible with packet writing data transmission.
- The disc on which MP3/WMA files and audio data (CDDA) are written may not be played if it is a CD-Extra or Mixed-Mode CD.

- The file/folder names that can be used per disc storage type are as follows, including the four-digit file name extensions (.mp3).
 - ISO 9660 Level 1: Maximum of 12 characters
 - ISO 9660 Level 2: Maximum of 31 characters
 - Joliet: Maximum of 64 characters (1 byte)
 - Windows long file name: Maximum of 128 Characters (1 byte)

Caution for using MP3/WMA music files

- This product can play MP3 (WMA) files with .mp3, .wma (lower case letters) or .MP3 and .WMA (capital letters) file name extensions.
- MP3 files that can be played by this product are as follows.
 - Bit rate: 8 kbps ~ 320 kbps

7-26 Infotainment System

- Sampling frequency: 48 kHz, 44.1 kHz, 32 kHz (for MPEG-1), 24 kHz, 22.05 kHz, 16 kHz (for MPEG-2)
- While this product can play files with an 8 kbps ~ 320 kbps bit rate, files with a bit rate above 128 kbps will result in high quality sound.
- This product can display ID3 Tag (Version 1.0, 1.1, 2.2, 2.3 or 2.4) information for MP3 files, such as the album name and the artist.
- To display album (disc title), track (track title), and artist (track artist) information, the file should be compatible with the ID3 Tag V1 and V2 formats.
- This product can play MP3 files using VBR. When playing an MP3 file of this VBR type, the remaining time displayed may be different from the real time.

Order of playing music files

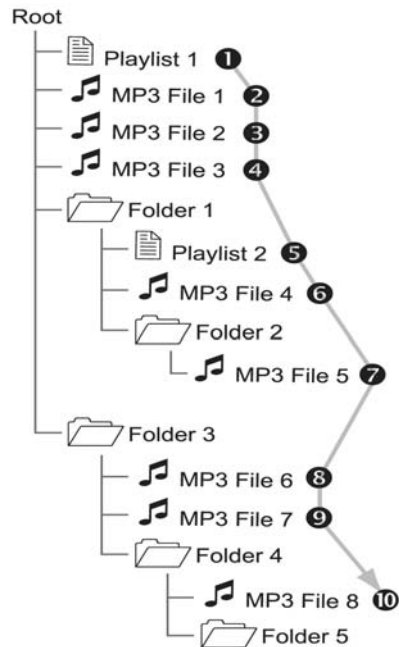

Playing CD/MP3

- (9) **CD/AUX** button
Select the CD/MP3 player.
- (14) **MENU** button with **TUNE** dial
 - Turn the dial to move to the track list, menu, or MP3 (WMA) track information item.
 - Press the button to display the menu screen for the current item or current mode.
- (8) **◀ SEEK ▶** buttons
 - Press these buttons to play the previous or next track.
 - Hold down these buttons to rewind or fast forward through the track, and release the button to resume playing at normal speed.
- (4) **EJECT**  button
Eject the disc.

- (7) **INFORMATION [INFO]** button
 Display the information for the track being played.
- (16) **MUTE [M]** button
 Hold down the button to turn the mute function on or off.
- (15) **BACK** button
 Cancel the input item or return to the previous menu.

Inserting and playing the CD/ MP3 disc

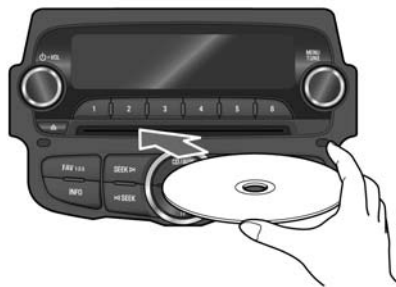

Insert the disc to be played with printed surface facing upward in the disc inserting slot.

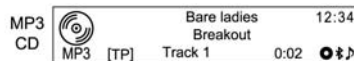

- Once the reading of disc information is completed, it will automatically play from track 1.
- When a non-readable disc is inserted, the disc will automatically be ejected with the display of a disc error message, and then the system will switch to the previously used function or the FM radio.

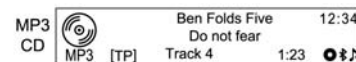

When a disc to be played is already inserted, repeatedly press **CD/AUX** button to select CD/MP3 play.

- If there is no disc to be played, "No CD Inserted" will be displayed on the screen and the function will not be selected.
- The track that was previously played will automatically play.

Eject disc



To end play, press the **EJECT** [] button to take out the disc.

- When the disc comes out, it automatically switches to the previously used function or the FM radio.
- The disc will automatically be reinserted if it is not taken out for some time.

Changing playing track

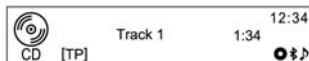

Press the **SEEK** buttons in play mode to play the previous or next track.

- Using the Steering wheel audio remote control, tracks can be easily changed by pressing the **SEEK** button.

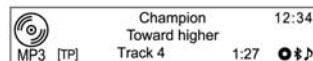
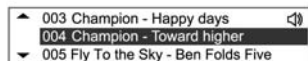

Or turn the **TUNE** dial to move to the play track list, and then press **MENU** button to instantly change it.

Changing playing position

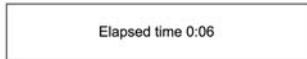

Hold down the **SEEK** buttons during play mode to rewind or fast-forward through the song.

Release the button to resume playing the song at normal speed.

- The volume is slightly reduced during rewinding and fast-forwarding, and the playing time will be displayed.

View information on playing track

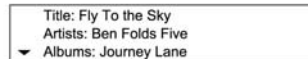

Press the **INFORMATION [INFO]** button in play mode to display information about the track being played.

- If there is no information on the playing track for audio CDs, then the system will display "No Information."

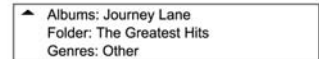
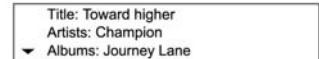
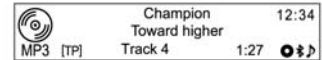

For MP3 (WMA) tracks, more information can be viewed by turning the **TUNE** dial from the track information display.

- The information displayed includes the file name, folder name, and ID3 Tag information saved with the song.

If incorrect ID3 Tag information (e.g. artist, song title) was added to MP3 (WMA) files before they are burnt to disc, this information will be displayed as is by the Infotainment system. Incorrect ID3 Tag information cannot be

7-30 Infotainment System

modified or corrected on the Infotainment system (ID3 Tags can only be corrected on a PC).

- The information for songs expressed in special symbols or in unavailable languages may be displayed as "____" or not displayed at all.

Using CD menu

Changing the playback mode

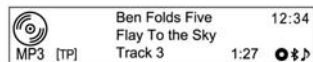

From the CD/MP3 play mode, press the **MENU** button to open the CD menu.

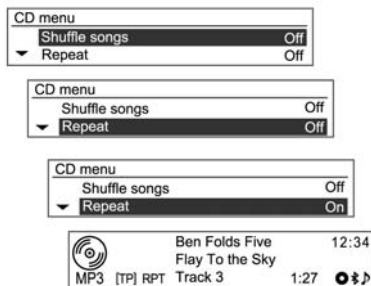

Turn the **TUNE** dial to select the Shuffle songs or Repeat playback functions, and then press the **MENU** button to turn the relevant functions On or Off.

CD menu → Track list

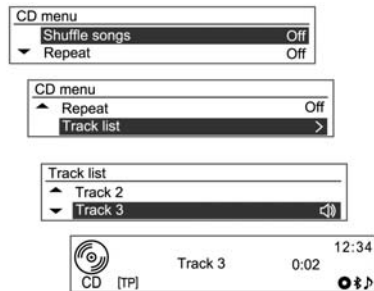

For Audio CD discs, turn the **TUNE** dial from the CD menu to select the Track list, and then press the **MENU** button.

Turn the **TUNE** dial to find the desired Track list, and then press the **MENU** button to play the selected track.

CD menu → Folders



For MP3 (WMA) disc, turn the **TUNE** dial from the CD menu to move to the Folders, and then press the **MENU** button

Turn the **TUNE** dial to select the desired folder, and then press the **MENU** button.

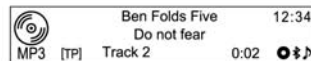
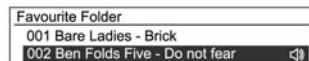

Turn the **TUNE** dial to find the desired track, and then press the **MENU** button to play the selected track from the selected folder.

CD menu → Search ...

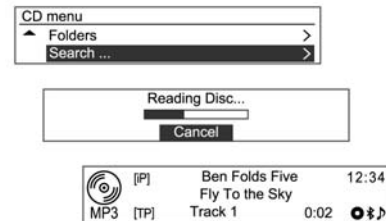

For MP3 [WMA] disc, turn the TUNE dial from the CD menu, move to the Search ..., and then press the MENU button.

- After the system reads the disc information, the first song of the playlist [iP] will be displayed.
- If there are no music files in the playlist [iP], the first song for each artist [iA] will be displayed.
- However, it may take a long time to read the disc depending on the number of music files.

7-32 Infotainment System

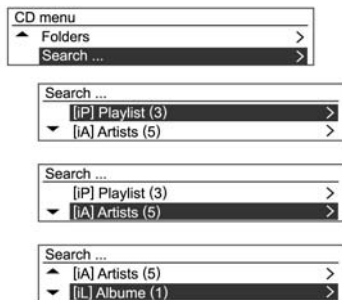

Press the **MENU** button again, and from the displayed search item, turn the **TUNE** dial to select the desired search item.

- The number of relevant songs will be displayed by Playlist [iP]/Artist [iA]/Album [iL]/Title [iS]/Genre [iG].

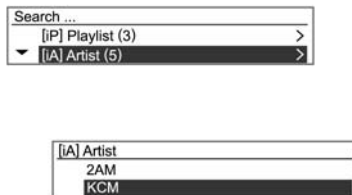

Turn the **TUNE** dial to select the detailed classification item, and then press the **MENU** button.

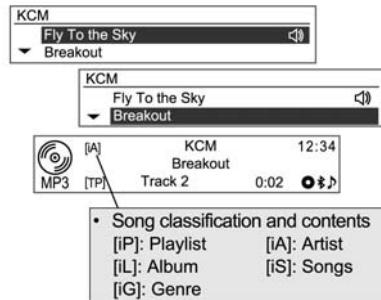

Turn the **TUNE** dial to find the desired track/title, and then press the **MENU** button to play the selected track.

Auxiliary Devices

USB player

Cautions for using USB devices

- Operation cannot be guaranteed if the HDD built-in USB mass storage device or CF or SD memory card is connected by

using a USB adaptor. Use a USB or flash memory type storage device.

- Take caution to avoid static electricity discharge when connecting or disconnecting the USB. If connection and disconnection are repeated many times in a short time, this may cause a problem in using the device.
- To separate the USB device, use the "USB menu → Remove USB" by using the **MENU** button with **TUNE** dial to carry out removal of the USB.
- Operation is not guaranteed if the connecting terminal of the USB device is not metal.
- Connection with i-Stick Type USB storage devices may be faulty due to vehicle vibration, so their operation cannot be guaranteed.
- Be careful not to touch the USB connecting terminal with an object or any part of your body.
- The USB storage device can only be recognised when it is formatted in FAT16/32 file format. Only devices with an allocated unit size of 512 Byte/Sector or 2,048 Byte/Sector can be used. NTFS and other file systems cannot be recognised.
- According to the type and capacity of the USB storage device and the type of the stored file, the time it takes to recognise the files may differ. This is not a problem with the product in this case, so please wait for the files to be processed.
- Files in some USB storage devices may not be recognised due to compatibility problems, and connections with a memory reader or a USB hub are not supported. Please check the device's operation in the vehicle before use.
- When devices such as an MP3 player, mobile phone, or digital camera are connected through a mobile disc, it may not operate normally.
- Do not disconnect the USB storage device while it is being played.
This may cause damage to the product or the performance of the USB device.
- Disconnect the connected USB storage device when the vehicle ignition is turned off. If the ignition is turned on while the USB storage device is connected, the USB storage device may be damaged or may not operate normally in some cases.

 **Caution**

USB storage devices can only be connected to this product for the purpose of playing music files.

(Continued)

Caution (Continued)

The product's USB terminal should not be used to charge USB accessory equipment since the heat generation using the USB terminal may cause performance issues or damage to the product.

- When the logical drive is separated from a mass USB storage device, only the files from the top-level logical drive can be played for USB music files. This is the reason that the music files to be played should be stored in the top-level drive of the device.

Music files in particular USB storage devices may also not be normally played if an application is loaded by partitioning a separate drive inside the USB device.

- Music files to which DRM (Digital Right Management) is applied cannot be played.
- This product can support USB storage devices that are up to 16 Gigabytes in capacity with a limit of 999 files, 512 folders, and 10 stages of folder structure. Normal usage cannot be guaranteed for storage devices that exceed this limit.

Caution for using USB music files

- Damaged music files may be cut-off during playback or may not be played at all.
- Folders and music files are displayed in the order of Symbol → Number → Alphabet → ...
- A maximum of 64 Korean/English characters can be recognised for folder or file names written in the Joliet file system.

About MP3 (WMA) music files

- The MP3 files that can be played are as follows.

- Bit rate: 8 kbps ~ 320 kbps
- Sampling frequency:
 - 48 kHz, 44.1 kHz, 32 kHz (for MPEG-1)
 - 24 kHz, 22.05 kHz, 16 kHz (for MPEG-2)
- This product displays MP3 (WMA) files with the mp3, .wma (lower case letters) or .MP3 or .WMA (capital letters) file name extensions.
- This product can display ID3 tag (Version 1.0, 1.1, 2.2, 2.3, 2.4) information about album, artist, etc. for MP3 files.
- The file/folder names that can be used according to storage type are as follows, including the four character file name extensions (.mp3).
 - ISO 9660 Level 1: Maximum of 12 characters
 - ISO 9660 Level 2: Maximum of 31 characters

- Joliet: Maximum of 64 characters (1 byte)
- Windows long file name: maximum of 128 characters (1 byte)
- This product can play MP3 files which use VBR. When a VBR type MP3 file is being played, the remaining time displayed may be different from the actual time remaining.

Main buttons/dial

The following main buttons and controls are used to play USB music files.

- (9) **CD/AUX** button
Press the button repeatedly when the USB device is connected to select the USB play mode.

- (14) **MENU** button with **TUNE** dial
 - Turn the dial to move to the track list, menu or MP3 (WMA) track information.
 - Press the button to display the menu screen provided by the current item or current mode.

- (8) **SEEK** buttons
 - Press these buttons to play the previous or next track.
 - Hold down these buttons to rewind or fast forward, and then release to play at normal speed.

- (7) **INFORMATION [INFO]** button
Display the information of the track being played.

- (16) **MUTE [MUTE]** button
Hold down the button to turn the mute function on or off.

- (15) **BACK** button
Cancel the input item or return to the previous menu.

Connecting the USB storage device



Connect the USB storage device with music files to be played to the USB connecting terminal.

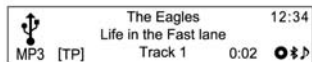
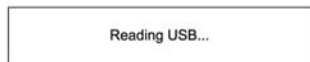

- Once the product finishes reading the information on the USB storage device, it will automatically play.
- If a non-readable USB storage device is connected, then an error message will appear and the product will automatically switch to the previously used function or the FM radio function.

If the USB storage device to be played is already connected, repeatedly press the CD/AUX button to select the USB player.

- It will automatically play from the previous playing point. Afterwards, the functions of the USB player are operated similarly to CD/MP3 playback.

Afterwards, the functions of the USB player are operated similarly to CD/MP3 playback.

Ending USB music files playback

Press the RADIO BAND or CD/AUX button to select other functions.

- To end play and disconnect the USB storage device, use the USB menu → Remove USB function to safely remove the USB storage device.

Using the USB menu

The instructions for "Shuffle songs/ Repeat/ Folder/Search ..." from the USB menu are similar to the CD/MP3 player's CD menu; only the "Remove USB" item has been added. Refer to the CD/MP3 player functions from the CD menu.

USB menu → Remove USB

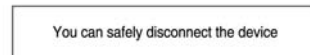

Press the **MENU** button from the play mode, to display the USB menu.

Turn the **TUNE** dial to move to the Remove USB, and then press the **MENU** button to display the message notifying you that it is safe to remove the USB device.

Disconnect the USB device from the USB connection terminal.

- Return to the previously used function.

iPod player

Main buttons/dial

The following main buttons and controls are used to play the iPod music files.

- (9) **CD/AUX** button
Press this button repeatedly when the iPod is connected to select the iPod play mode.
- (14) **MENU** button with **TUNE** dial
 - Turn the dial to move and display the track list that is playing.
 - Press the button to display the menu screen provided by the current item or current mode.

- (8) **SEEK** buttons
 - Press these buttons to play the previous or next track.
 - Hold down these buttons to rewind or fast forward, and then release to play at normal speed.
- (7) **INFORMATION [INFO]** button
Display the track being played.
- (16) **MUTE [M]** button
Hold down the button to turn the mute function on or off.

Connecting iPod player



Connect the iPod with music files to be played to the USB connecting terminal.

- Some iPod/iPhone product models may not be supported.

Only connect the iPod to this product with connection cables supported by iPod products. Other connection cables cannot be used.

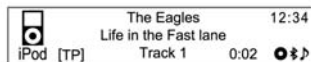

- In some cases, the iPod product may be damaged if the ignition is turned off when it is connected to the product.

When the iPod product is not being used, keep it separately from this product with the car ignition turned off.

- Once the product finishes reading the information on the iPod device, it will play automatically.
- If a non-readable iPod device is connected, then the relevant error message will appear and

the product will automatically switch to the previously used function or the FM radio function.

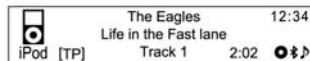

If the iPod device to be played is already connected, repeatedly press **CD/AUX** button to select the iPod player.

- It will automatically play from the previously played point.
- The playback functions and the information display items of the iPod player used with this product may be different from

the iPod in terms of play order, method, and the information displayed.

- Refer to the following table for the classification items related to the search function provided by the iPod product.

	Step 1	Step 2	Step 3	Step4
Playlist	Playlist	Song		
Genre	Genre	Artist	Album	Song
Artist	Artist	Album	Song	
Composer	Composer	Album	Song	
Album	Album	Song		
Audiobooks	Song			
Songs	Song			
Podcasts	Program	Episode		

Afterwards, the functions to play the iPod are operated similarly to CD/MP3 playback.

Log-off iPod playback

To end playback, press the **RADIO BAND** or **CD/AUX** button to select other functions.

Using the iPod menu

From the iPod menu, the instructions for "Shuffle songs/ Repeat/Search..." (including Audio books and Composers)" are similar to CD/MP3 player's CD Menu; only the "Remove iPod" item has been added. Refer to each item of CD/ MP3 for use.

iPod menu → Remove iPod



You can safely disconnect the device

Press the **MENU** button from the play mode, to display the iPod menu.

Turn the **TUNE** dial to move to the Remove iPod function, and then press the **MENU** button to display the message notifying you that it is safe to remove the device.

Separate the iPod device from the USB connection terminal.

- Return to the previously used function.

Exterior Sound (AUX) Input

Main buttons/dial

The following main buttons and controls are used to enjoy the rich sound of the Infotainment system from the sound output of a connected exterior sound device.

- (9) **CD/AUX** button
When an exterior sound device connected, press the button to select the exterior sound (AUX) input mode.
- (2) **POWER** button with **VOLUME** dial
Turn the dial to adjust the volume.

- (1- **MUTE** [🔇] button
- 6) Hold down the button to turn the mute function on or off.

Connecting an exterior sound



Connect the audio output of the external audio equipment to AUX input terminal.

- The Infotainment system will automatically switch to the exterior sound (AUX) input mode when the exterior sound device is connected.



Press the **CD/AUX** button to switch to the exterior sound input mode if the exterior sound system has already been connected.

Turn the **VOLUME [VOL]** dial to adjust the volume.

Personalisation

Main buttons/dial

The buttons and dial used in the system set-up are as follows.

- (12) **CONFIG** button
Press this button to enter the system Settings menu.
- (14) **MENU** button with **TUNE** dial
 - Turn the dial to move to the menu or set-up item.
 - Press the button to select/enter the detailed control screen provided by the current menu or set-up item.
- (15) ↶ **BACK** button
 - Cancel the input item or return to the previous screen/menu.

How to use the Settings menu for personalisation

- Settings menus and functions may differ according to car model.
- Reference: Table of information for settings on the next page

[Example] Settings → Time Date
→ **Set date: May 25th 2013**



Press the **CONFIG** button for the Settings menu.

After referring to the Table of information for settings on the next page, turn the **TUNE** dial to move to the desired Settings menu, and then press **MENU** button.



- Indicates the detailed list for the relevant set-up menu or functioning state.
- If there is another detailed list from the relevant detailed list, you can repeat this action.

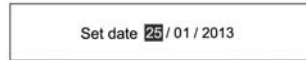

Turn the **TUNE** dial to attain the desired set-up value or functioning state, and then press **MENU** button.

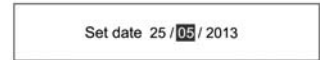
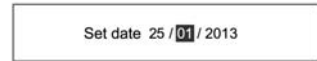

- If the relevant detailed list is made of several items, then repeat this action.
- Set/enter the relevant set-up value or the functioning state will change.

Table of information for settings

[Languages]



Select the desired language for displaying.

[Time Date]



Set time: Manually set the hours and minutes for the current time.

Set date: Manually set the current year/month/date.

Set time format: Select 12h or 24h time display

Set date format: Set the date is display format.

YYYY/MM/DD : 2013 May 23
DD/MM/YYYY : 23 May 2013
MM/DD/YYYY : May 23, 2013

RDS clock synchronisation:
Select On or Off

[Radio Settings]

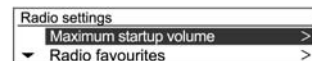

Maximum start-up volume:
Manually set max limit for the start-up volume.

Radio favourites: Manually set your Favourites page numbers.

RDS options: Set the RDS options.

- **RDS:** On/Off (activate or deactivate the RDS function).
- **Regional:** On/Off (activate or deactivate the Regional function).

- **Text scroll freeze:** On/Off (activate or deactivate the Text scroll freeze function).
- **TA volume:** Set the TA volume.

DAB settings (only for Type A):
Set the RDS options.

- **Auto ensemble linking:** On/Off (activate or deactivate the Auto ensemble linking function).
- **Auto linking DAB-FM:** On/Off (activate or deactivate the Auto linking DAB-FM function).
- **Dynamic audio adaption:** On/Off (activate or deactivate the Dynamic audio adaption function).
- **Band selection:** Set the Both, L-band or Band III.

[Bluetooth Settings]

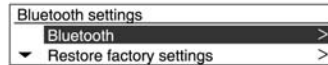

Bluetooth: Enter the Bluetooth menu.

- **Activation:** Select On or Off.
- **Device list:** Select the desired device and select/connect/separate or delete.
- **Pair device:** Try pairing a new Bluetooth device.

- **Change bluetooth code:** Manually change/set the Bluetooth code.
- **Restore factory settings:** Restore all settings to the default settings.

Phone

Bluetooth

Main buttons/dial

The following main buttons and controls are used to play music files or use the call functions via a Bluetooth device.

(9) **CD/AUX** button

When a Bluetooth device with a music player function is connected, press this button repeatedly to select Bluetooth audio play mode.

(14) **MENU** button with **TUNE** dial

- Press the button from Bluetooth phone mode to display the menu screen.
- Turn the dial to move to the menu or set-up value.

(8) **SEEK** buttons

- Press these buttons in Bluetooth audio play mode to play the previous or next track.
- Hold down these buttons to rewind or fast forward, and release to play at normal speed.

(15) **BACK** button

- Cancel the previous item or return to the previous menu.

(16) **PHONE** [📞] / **MUTE** [🔇] button

- Press this button to activate Bluetooth mode or make a call.
- Hold down the button to turn the mute function on or off.

Connecting Bluetooth

Registering the Bluetooth device

Register the Bluetooth device to be connected to the Infotainment system.

- Firstly, set up the Bluetooth device to be connected from the Bluetooth settings menu to enable other devices to search for the Bluetooth device.

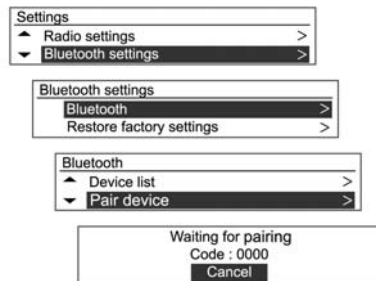

Press the **CONFIG** button, and use the **MENU** button with TUNE dial to move to Settings → Bluetooth settings → Bluetooth → Pair device, and then press the **MENU** button.

- Bluetooth devices can be registered not only by using **CONFIG** button, but also by using Phone menu → Bluetooth settings → Bluetooth → Add device.
- If there already is a Bluetooth device connected to the Infotainment system, the "Bluetooth is busy" message will appear.
- Connection standby will be displayed with a message and a security code. (The initial value is 0000, and can be changed from Settings → Bluetooth settings → Bluetooth → Change Bluetooth code item.)

The Infotainment system can be found by searching the to-be-connected Bluetooth device.

Enter the security code for the Infotainment system through the Bluetooth device.

If the registration of device to be connected to the Infotainment system is successful, then the screen will display the information of the Bluetooth device.



- The Infotainment system can register up to five Bluetooth devices.
- In some Bluetooth devices, it is only possible to use it when "Always connect" item is set.

Connecting/Deleting/Separating the Bluetooth Devices

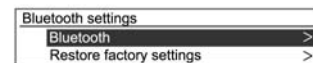

Caution

If there is a Bluetooth device already connected, that device needs to be disconnected first.

Firstly, set up the Bluetooth device to be connected from the Bluetooth set-up menu to enable other devices to search for the Bluetooth device.

7-46 Infotainment System

Press the **CONFIG** button, and use the **MENU** button with **TUNE** dial, to move to the Settings → Bluetooth settings → Bluetooth → Device list, and then press the **MENU** button.

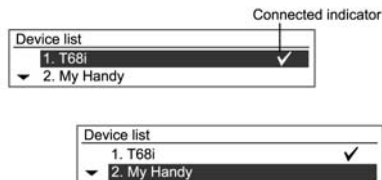

Use the **MENU** button with **TUNE** dial to move from the registered Bluetooth device to the device to be connected, and then press the **MENU** button.

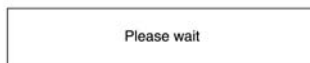

You can register by using the **MENU** button with **TUNE** dial, moving to select the item, moving to delete the item to delete, and then pressing the **MENU** button.

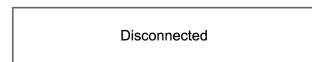

- Disconnecting the currently connected Bluetooth device, from the Device list screen, select the connected device, which will display Disconnect item, and then press the **MENU** button.

Cautions for registering/ connecting Bluetooth

- When it is not possible to connect to Bluetooth, delete the entire device list from the Bluetooth to be connected, and try again. If deleting the entire

device list does not work, then remove the battery and reconnect.

- If there is a problem after the Bluetooth device is connected, use the **MENU** button with **TUNE** dial to carry out the Settings → Bluetooth settings → Restore factory settings.

Initialise the device with the problem caused by an error that occurred with the connection of the Bluetooth device and the Infotainment system.

- Sometimes, Bluetooth can only be connected through hands-free or the Bluetooth audio play functions despite a stereo headset being connected. In this case, try and reconnect the Infotainment system using the Bluetooth device.
- For Bluetooth devices that do not support stereo headsets, the Bluetooth audio play function cannot be used.

- It is not possible to listen to the music through the Bluetooth audio if an iPhone is connected through a USB connector. This is because of the unique specifications of the mobile phone.

Bluetooth audio

How to play Bluetooth audio

- A mobile phone or Bluetooth device that supports A2DP (Advanced Audio Distribution Profile) versions over 1.2 must be registered and connected to the product.
- From the mobile phone or Bluetooth device, find the Bluetooth device type to set/ connect the item as a stereo headset.

A musical note icon [🎵] will appear at the bottom right of the screen if the stereo headset is successfully connected.

- Do not connect the mobile phone to Bluetooth connection terminal. An error may occur if it is connected during the CD/MP3 and Bluetooth audio play mode.

Playing Bluetooth audio



Press the **CD/AUX** button repeatedly to select the connected Bluetooth audio play mode.

- If the Bluetooth device is not connected, then this function cannot be selected.

7-48 Infotainment System

Activating the mobile phone or Bluetooth device will play the music files.

- The sound played by the Bluetooth device is delivered through the Infotainment system.
- For Bluetooth audio to play, the music must at least be played once from the music player mode of the mobile phone or Bluetooth device after connecting as a stereo headset. After being played at least once, the music player will automatically play upon entering play mode, and it will automatically stop when the music player mode ends. If the mobile phone or Bluetooth device is not in the waiting screen mode, some devices may not automatically play in Bluetooth audio play mode.

Press the **SEEK** buttons to switch to the previous or next track, or hold down these buttons to rewind or fast forward.

- This function only operates with Bluetooth devices that support AVRCP (Audio Video Remote Control Profile) version 1.0 or above. (Depending on the Bluetooth device options, some devices may display AVRCP being connected for the initial connection.)
- The information about playing track and track position will not be displayed on the Infotainment system screen.

Cautions for playing Bluetooth audio

- Do not change the track too quickly when playing Bluetooth audio.
It takes some time to transmit data from the mobile phone to the Infotainment system.

- Do not change the track too quickly when playing Bluetooth audio.

It takes some time to transmit data from the mobile phone to the Infotainment system.

- If the mobile phone or Bluetooth device is not in the waiting screen mode, it may not automatically play despite being carried out from the Bluetooth audio play mode.

If Bluetooth audio playback is not functioning, then check to see if the mobile phone is in the waiting screen mode.

- Sometimes, sounds may be cut off during the Bluetooth audio playback.

The Infotainment system outputs the audio from the mobile phone or Bluetooth device as it is transmitted.

Bluetooth error messages and measures

- Bluetooth deactivated Check if Bluetooth activation is set-up as ON. The Bluetooth function can be used upon turning on Bluetooth activation.
- Bluetooth is busy Check if there are any Bluetooth devices connected. To connect another device, disconnect any other connected devices first, and then reconnect.
- Device list is full. Check if there are less than 5 registered devices. No more than 5 devices can be registered.
- No phone book available

This message will be displayed if the mobile phone does not support contacts transmission. If this message appears after several attempts, then the device does not support contacts transmission.

⚠ Caution

The message will be displayed when the transmission of contacts is supported while information with a device error is also transmitted. Update the device again if this occurs.

- Phone book is empty This message is displayed if no phone numbers are stored in the mobile phone.
This will also be displayed if the phone log transmission is supported, but in a way that is not supported by the Infotainment system.

Hands-Free Phone

Taking calls

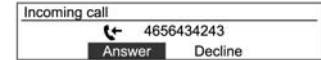

When a phone call comes through the connected Bluetooth mobile phone, the playing track will be cut off and the phone will ring with the relevant information displayed.

Caution

It is possible to transfer your ringtone depending on the mobile phones. Adjust the ringtone volume of the mobile phone if the volume is too low.

To talk on the phone, press **Call** button on the steering wheel audio control or turn the **TUNE** dial to move to the Answer function, and then press the **MENU** button.

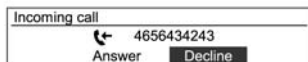

- To reject a call, press the **Hang up/Mute** button on the steering wheel audio control or select the Decline by using the **MENU** button with **TUNE** dial.

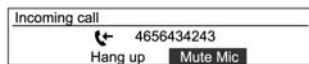

- While conversing, it is possible to block the transmitted sound by selecting the Mute Microphone item by using the **MENU** button with **TUNE** dial.



- While conversing, hold down the **Call** button from the steering wheel audio control to change to the private call mode (some phones may not support the private call mode depending on the phone's options).
- When a call is received with the Infotainment system and Bluetooth is being connected, there are mobile phones that do not automatically change to the private call mode. This depends on the original specifications of each mobile phone.

- When it is possible to use services related to a third-party conversation supported by the communications service provider through an application, it is possible to make calls during a call through the Infotainment system.
- While third or more-party conversing, displaying contents may differ from practical information.

Ending a call



To end the a call, press **Hang up/ Mute** button on the steering wheel audio control or turn the **TUNE** dial to move to the Hang up, and then press the **MENU** button.

Calling by Re-dial

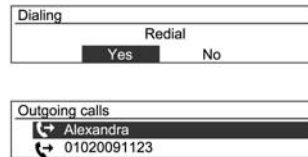

From the steering wheel audio control, press the **Call** [📞] button to display the redial guidance screen, or hold down the button to display the caller log screen.

Turn the **TUNE** dial to select Yes or contacts, and then press the **MENU** button or **Call** [📞] button to make a call.

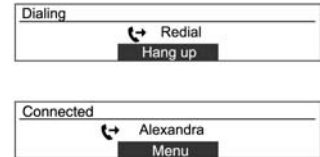

- If the mobile phone is not in waiting mode, your phone might not support the redial function. This depends on the mobile phone's options.
- When making redialling a number, the connected phone number will not be displayed.

7-52 Infotainment System

- Depending on the mobile phone, there are cases in which the call is made through the call history of the received or missed calls instead of the redial mode. This depends on the mobile phone's options.

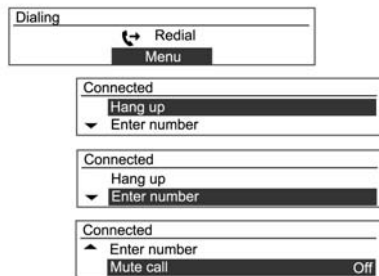

Press the **MENU** button while the phone is connected to display the connecting functions as shown above.

Use MENU button with **TUNE** dial to select the functions in the menu that appears.

- While conversing on the phone, hold down the **Call** [📞] button on the steering wheel audio control to switch to Private Mode.

Calling by Entering numbers

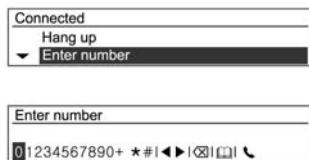

To make a call by entering the phone number, press the **MENU** button and turn the **TUNE** dial to select Enter number, and then press the **MENU** button.

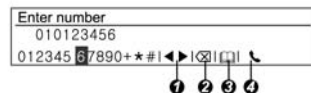

Turn the **TUNE** dial to select the desired letters, and then press the **MENU** button to enter the number.

- Repeat this item to enter all telephone numbers.
- Press the **BACK** button to delete a letter one by one, or hold down the button to delete all content that has been entered.
- Refer to the following contents to edit the input contents.
(1) Move: Move input position

- (2) **Delete:** Delete input character
- (3) **Phone book:** Search contacts (usable after updating the phone numbers)
- (4) **Dial:** Begin dial

Enter number
010123456789
1234567890+*# ◀▶ ⊗ □ ■

Dialing
↻ 010123456789
Hang up

Connected
↻ 010123456789
Menu

After the telephone number has been fully entered, turn the **TUNE** dial to select begin dial [↻], and then press the **MENU** button to make a call.

To end a call, turn the **TUNE** dial to choose the Hang up menu, and then press the **MENU** button.

Using the Phone menu

Phone menu → Phone book → Search

Phone menu
Enter number >
▼ Phone book >

Phone book
Search
▼ Update

Search
First name
Last name

Press the **MENU** button, turn the **TUNE** dial to select Phone book, and then press the **MENU** button.

- A notification will appear on screen, with no contacts to use, and you will be returned to the previous menu.

Turn the **TUNE** dial to select Search, and then press the **MENU** button.

Turn the **TUNE** dial to select First or Last name, and then press **MENU** button.

Search
ABC DEF GHI JKL MNO
PQRS TUV WXYZ 0-9 etc

Turn the **TUNE** dial to select search terms/range, and then press the **MENU** button.

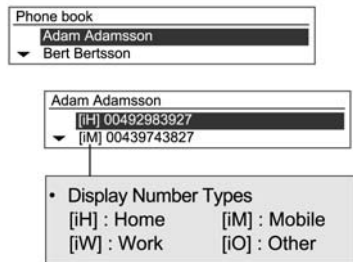

Turn the **TUNE** dial from the search results screen to select the desired item, and then press the **MENU** button to view the details for that item.

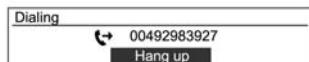

To call the relevant number, press the **MENU** button.

- For more directions, refer to the making phone calls item.

Phone menu → Phone book → Update



Update the contacts of the connected mobile phone to the system's contacts.

Using the **MENU** button with **TUNE** dial, select the Phone menu → Phone book → Update, and then press the **MENU** button.

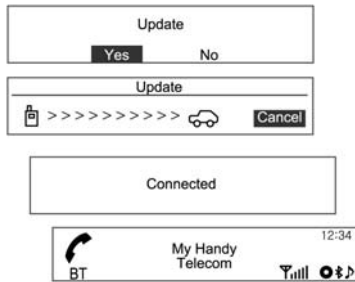

Turn the **TUNE** dial to select Yes or No, and then press the **MENU** button to activate or cancel update.

Notice for updating contacts

- This function can be used with mobile phones that support contacts update and the call history transmission function. (If the product is connected to a mobile phone that does not support these functions, the call history can be displayed through the Infotainment system.)
- Update is not supported for more than 1,000 contact numbers.

- Be aware that hands-free and Bluetooth audio playback will be cut-off while proceeding with updates for contacts. (Other functions except for hands-free and Bluetooth audio playback can be used.)
- To update your contacts, it is possible to request for the transmission certification for contacts. If the waiting screen does not change for a long time, you can check whether the mobile is requesting for certification. When requesting for certification of the mobile phone, all Bluetooth connections will be cut off if it is not accepted, and then the device will be reconnected.

- When receiving the call history, it is possible to request for the transmission certification for the call history from the mobile phone. If the waiting screen does not change for a long time, check whether the mobile is requesting for certification. When requesting for the certification of the mobile phone, all Bluetooth connections will be cut off if it is not accepted, and then the device will be reconnected.
- If there is a problem in the stored information of the mobile phone, the contacts may not be updated.
- The Infotainment system only uses information coded in UTF-8 format.

7-56 Infotainment System

- If other operations (game, map search, navigation, etc.) are activated during the contacts update or call history transmission progress, the update/ transmission process may not work.

This is because other operations running on the mobile phone are affecting the data transmission.
- When the contacts update or call history transmission is completed, all hands-free and Bluetooth audio play modes will be automatically disconnected and then reconnected.
- If the Infotainment system gets turned off while conversing on the phone, the call will be transmitted to the mobile phone. Some phones may need to set-up a call transmission function beforehand, depending on the type of the phone.
- If the user disconnects the connection directly (using the Infotainment or mobile phone), the auto connection function does not take place.

Auto-connection: This function automatically finds and connects the device that was last connected.
- The contacts may not always display all the lists on the phone when selected. The Infotainment system only displays what has been transmitted from the mobile phone.
- The contacts update can only receive four numbers per contacts directory (Mobile Phone, Office, Home, and Other).
- Changing the language set-up during the contacts update will delete all previous updates.
- If the mobile phone is not set with a waiting screen, calls may not be made to this Infotainment system.
- If the OS of the mobile phone gets updated, it may change how the phone's Bluetooth function works.
- Special characters and unsupported languages will be displayed as "_____".
- Calls registered in the contacts without any name will be indicated as "No number in contact."
- The Infotainment system will display contacts, call history, and redial information as it is transmitted from the mobile phone.

Phone menu → Phone book →
Delete all

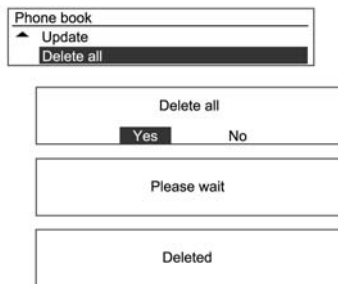

Every single phone number that has been stored in the system contacts will be deleted.

Use the **MENU** button with **TUNE** dial to select the Phone menu → Phone book → Delete all, and then press the **MENU** button.

Turn the **TUNE** dial to select Yes or No, and then press the **MENU** button to delete all contacts or to cancel.

Phone menu → Call lists

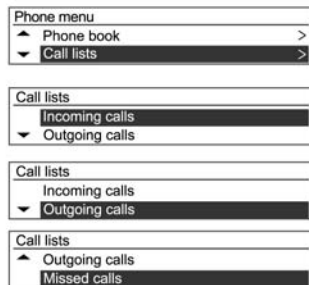

Check, use, or delete contacts.

Use the **MENU** button with **TUNE** dial to select the Phone menu → Call lists, and then press the **MENU** button.

Use the **TUNE** dial to select the detailed call history, and then press the **MENU** button.

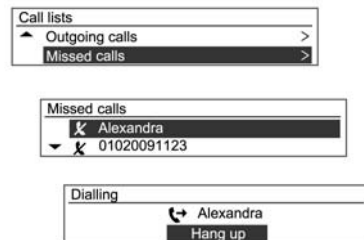

Turn the **TUNE** dial to check the call history and to make a call.

Press the **MENU** button to call the selected number from the call history.

- If the "Please Wait" screen continues to be displayed for too long after selecting the call log, check if the mobile phone is requesting verification of the transfer of call numbers. After completing the mobile phone verification procedures, the

7-58 Infotainment System

contacts and the call log will be transmitted to the Infotainment System.

- The call log from the mobile phone and the log displayed on Infotainment may be different. This Infotainment System shows the information transmitted from the mobile phone as it is.

Phone menu → Bluetooth settings

Set-up Bluetooth function.

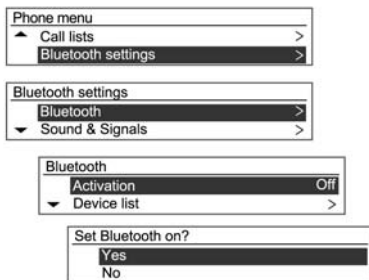

Use the **MENU** button with **TUNE** dial to select the Phone menu → Bluetooth settings, and then press the **MENU** button.

To activate the Bluetooth function, register/connect/delete the Bluetooth device or change the Bluetooth code, choose Bluetooth by using the **MENU** button with **TUNE** dial, and then use the MENU button to set up the desired item.

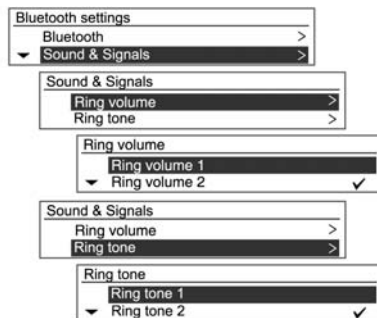

To set up the Ring tone and its volume used by the Bluetooth function, use the **MENU** button with **TUNE** dial to select Sound &

Signals, and then set up the desired items with the **MENU** button with **TUNE** dial.

- It is possible the ringtones you already have are transferred to the Infotainment System depending on the mobile phone. For such mobile phones, it is not possible to use the selected ringtone.
- For mobile phones that transfer your ringtones, the volume of the ringtone will be based on the volume transmitted from the mobile phone. Adjust the ringtone volume of the mobile phone if the volume is too low.

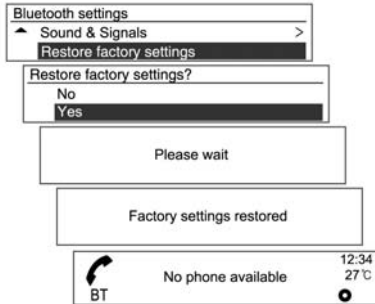

To reinitialise the Bluetooth settings to their default values, use the **MENU** button with **TUNE** dial to select the Restore factory settings item, and then select Yes with the **MENU** button.

Climate Controls

Climate Control Systems

Heating and Ventilation System	8-1
Air Conditioning System	8-5

Air Vents

Adjustable Air Vents	8-9
Fixed Air Vents	8-10

Maintenance

Air Intake	8-10
Passenger Compartment Air Filter	8-11
Air Conditioning Regular Operation	8-12
Service	8-12

Climate Control Systems

Heating and Ventilation System





<Type 1>



<Type 2>

Controls for:

- Temperature
- Air distribution
- Fan speed
- Heating
- Defrosting windscreen
- Air recirculation 
- Heated rear window  *Heated Rear Window on page 2-16*

8-2 Climate Controls

Temperature

Adjust the temperature by turning the knob.

red: Warm

blue: Cold

Heating will not be fully effective until the engine has reached normal operating temperature.

Air distribution

Select air outlet by turning the centred knob.

 : Air flow is directed to the upper body and floor.

 : to foot well, with a small amount of the air being directed to windscreen, front door windows and side air vents.

 : to head area via adjustable air vents

 : to windscreen and foot well, with a small amount of the air being directed to front door windows and side air vents.

 : to windscreen and front door windows, with a small amount of the air being directed to side air vents.

Fan speed

Adjust the air flow by switching the fan to the desired speed.

Heating

Normal heating

1. Type 1: Move recirculation lever to the right for the recirculation mode.

Type 2: Press the recirculation button for the recirculation mode. An indicator light comes on to show that the recirculation is on.

2. Turn air distribution knob.

3. Turn fan control knob to desired speed.

Maximum heating

Use the maximum heating mode for quick heating of the passenger area.

Do not use it for lengthy periods. It can result in an accident because the interior air may become stale and the windows may mist causing loss of driver's visibility.

To clear the windows:

Type 1: Turn the air distribution knob to  and move the recirculation lever to the left to allow fresh air into the vehicle.

Type 2: Turn the air distribution knob to  and set the recirculation mode to outside air mode to allow fresh air into the vehicle.

For maximum heating:

1. Type 1: Move recirculation lever to the right for the recirculation mode.

Type 2: Press the recirculation button for the recirculation mode. An indicator light comes on to show that the recirculation is on.

2. Turn temperature control knob all the way to the red area for heating.
3. Turn fan control knob to maximum speed.



Defrosting the windscreen



<Type 1>





<Type 2>

1. Type 1: Set the recirculation mode to outside air mode and turn the air distribution knob to DEFROST .
Type 2: Turn the air distribution knob to DEFROST , then the recirculation mode is fixed to outside air mode automatically.
The air conditioning system operates but the indicator light is not changed.
2. Turn temperature control knob to red area for warm air.
3. Adjust the fan control knob to highest speed for quick defrosting.
4. Open side air vents as required and direct them towards the door windows.

8-4 Climate Controls

Warning

The difference between the outside air and the temperature of the windscreen can cause the windows to mist up, thereby restricting your front vision.

Do not use FLOOR/DEFROST  or DEFROST  in extremely humid weather when the temperature control knob is set to the blue area.

This can lead to an accident which can damage your vehicle and cause personal injuries.

Air recirculation system



<Type 1>

The air recirculation mode is operated with the  lever.



<Type 2>

The air recirculation mode is operated with the  button.

An indicator light comes on to show that the recirculation is on.

* When operating in DEFROST mode, recirculation is to be fixed to outside air mode to provide fast clear vision condition of windscreen.

Warning

Driving with recirculation mode for prolonged period of time can make you sleepy. Periodically turn to the outside air mode for fresh air.

The exchange of fresh air is reduced in air recirculation mode.

In operation without cooling the air humidity increases, so the windows may mist up. The quality of the passenger compartment air deteriorates, which may cause the vehicle occupants to feel drowsy.

Heated rear window

The heated rear window is operated with the  button.

An indicator light comes on to show that the feature is on.

Heated rear window  *Heated Rear Window on page 2-16.*

Air Conditioning System**Warning**

Do not sleep in a vehicle with the air conditioning or heating system on. It may cause serious harm or death due to a drop in oxygen content and/or body temperature.



**Type 1**

8-6 Climate Controls



Type 2

Controls for:

- Temperature
- Air distribution
- an speed
- Demisting and Defrosting
- Air recirculation 
- Cooling 
- Heated rear window

Temperature

Adjust the temperature by turning the knob.

red: warm

blue: cold

Air distribution

Select air outlet by turning the centred knob.

 : to head area and foot well

 : to foot well, with a small amount of the air being directed to windscreen, front door windows and side air vents.

 : to head area via adjustable air vents

 : to windscreen and foot well, with a small amount of the air being directed to front door windows and side air vents.

 : to windscreen and front door windows, with a small amount of the air being directed to side air vents.

Fan speed

Adjust the air flow by switching the fan to the desired speed.



Demisting the windscreen



Type 1



Type 2

1. Type 1: Set the recirculation mode to outside air mode and turn the air distribution knob to DEFROST .
Type 2: Turn the air distribution knob to DEFROST , then the recirculation mode is fixed to outside air mode automatically.
2. Type 1: Switch on cooling .
Type 2: The air conditioning system operates but the indicator light is not changed.

3. Select desired temperature.
4. Adjust the fan control knob to the desired speed.

Air recirculation system



Type 1

The air recirculation mode is operated with the  lever.



Type 2

The air recirculation mode is operated with the  button.
An indicator light comes on to show that the recirculation is on.
* When operating in DEFROST mode, recirculation is to be fixed to outside air mode to provide fast clear vision condition of windscreen.

8-8 Climate Controls

Warning

Driving with recirculation mode for prolonged period of time can make you sleepy. Periodically turn to the outside air mode for fresh air.

The exchange of fresh air is reduced in air recirculation mode.

In operation without cooling the air humidity increases, so the windows may mist up. The quality of the passenger compartment air deteriorates, which may cause the vehicle occupants to feel drowsy.

Cooling

Type 1:

Operated with the  button and is functional only when the engine and fan are running.

Type 2:

Operated with the  button and is functional only when the engine and fan are running. An indicator light comes on to show that the air conditioning is on.

* When operating in Defrost mode, A/C switch comes on and is to be fixed to A/C ON without indicator status change.

The air conditioning system cools and dehumidifies (dries) as soon as outside temperature is a little above the freezing point. Therefore condensation may form and drip from under the vehicle.

If no cooling or drying is required, switch off the cooling system to save fuel.

The air conditioning will not operate when the fan control knob is in the off position.

Even though the air-conditioning is turned on, the vehicle will produce warm air if the temperature knob is set to the red area.

To turn off the air conditioning system, turn the fan knob to 0.

Caution

Use only correct refrigerant

Warning

Climate control systems have to be serviced exclusively by qualified personnel. Improper service methods may cause personal injury.

Normal cooling

1. Operate the air conditioning system.
2. Turn temperature control knob to blue area for cooling.
3. Turn the air distribution knob.
4. Adjust the fan control knob to the desired speed.

Maximum cooling**Type 1****Type 2**

To achieve maximum cooling during hot weather and when your vehicle has been exposed to the sun for a long time:

1. Operate the air conditioning system.
2. Type 1: Move recirculation lever to the right for the recirculation mode.
Type 2: Press the recirculation button for the recirculation mode.
3. Turn temperature control knob all the way to the blue area for cooling.
4. Turn fan control knob to highest speed.

Air Vents**Adjustable Air Vents**

At least one air vent must be open while cooling is on in order to prevent the evaporator from icing up due to lack of air movement.

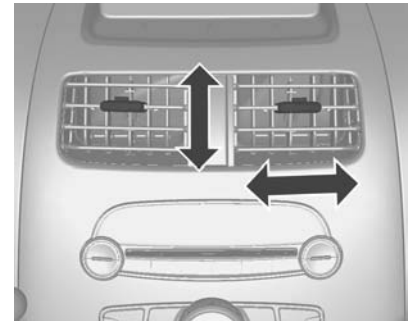

The central vent is not closed completely.

Direct the flow of air by tilting and swivelling the slats.

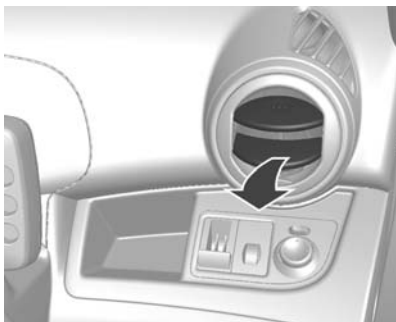

Turn the knob anticlockwise to open the side vents, and rotate it to the direction you want.

If you do not want the flow, turn the knob clockwise.

Warning

Do not attach any objects to the slats of the air vents. Risk of damage and injury in case of an accident.

Fixed Air Vents

Additional air vents are located beneath the windscreen and front door windows and in the foot wells.

Maintenance

Air Intake

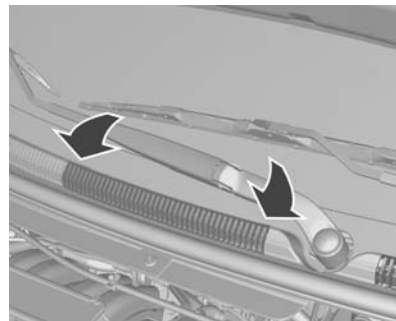

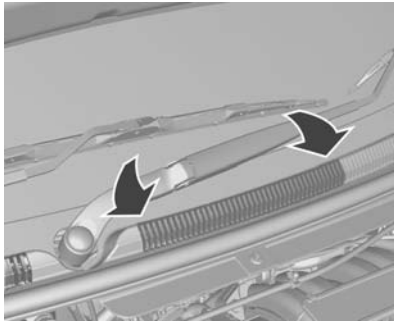

The air intake in front of the windscreen in the engine compartment must be kept clear to allow air intake. Remove any leaves, dirt or snow.

Passenger Compartment Air Filter

Passenger compartment air filter

The filter cleans dust, soot, pollen and spores from the air entering the vehicle through the air intake.

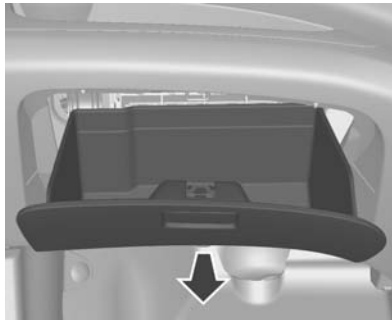
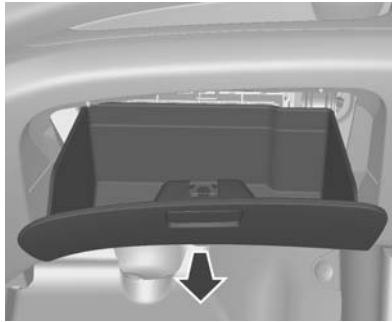

Filter replacement:

1. Remove the glovebox.

To remove the glovebox, open and pull it up on each side.

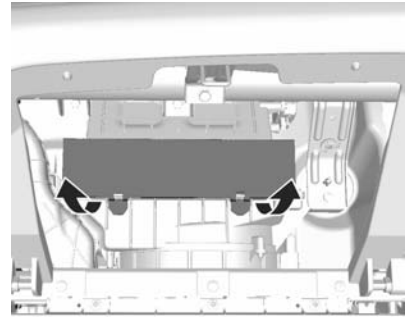

2. Remove the filter cover by pulling up the cover.
3. Replace the passenger compartment air filter.
4. Assemble the filter cover and glovebox in reverse order.

See your dealer if additional assistance is needed.

8-12 Climate Controls

Note: We recommend that you consult your authorised workshop to replace the filter.

Caution

More frequent maintenance of the passenger compartment air filter is required if the driving circumstances are dusty roads, air pollution areas, and frequent unpaved roads.

The filter efficiency is decreased and the bronchus is badly affected. The filter efficiency is decreased and the bronchus is badly affected.

Air Conditioning Regular Operation

In order to ensure continuously efficient performance, cooling must be operated for a few minutes once a month, irrespective of the weather

and time of year. Operation with cooling is not possible when outside temperature is low.

Service

For optimal cooling performance, it is recommended to annually check the climate control system:

- Functionality and pressure test
- Heating functionality
- Leakage check
- Check of drive belts
- Cleaning of condenser and evaporator drainage
- Performance check

Caution

Use only correct refrigerant

Warning

Climate control systems have to be serviced exclusively by qualified personnel. Improper service methods may cause personal injury.

Driving and Operating

Driving Information

Control of a Vehicle 9-1

Starting and Operating

New Vehicle Run-In 9-2

Ignition Positions 9-2

Starting the Engine 9-3

Parking 9-3

Engine Exhaust

Engine Exhaust 9-4

Catalytic Converter 9-4

Automatic Transmission

Automatic Transmission 9-4

Selector Lever 9-5

Fault 9-8

Interruption of Power

Supply 9-8

Manual Gearbox

Manual Gearbox 9-9

Brakes

Brakes 9-10

Antilock Brake

System (ABS) 9-11

Parking Brake 9-12

Brake Assist 9-12

Ride Control Systems

Electronic Stability

Control (ESC) 9-13

Object Detection Systems

Parking Assist 9-14

Fuel

Fuel for Petrol Engines 9-16

Filling the Tank 9-16

Fuel Consumption -

CO₂-Emissions 9-18

Driving Information

Control of a Vehicle

Never coast with engine not running

Many systems will not function in this situation (e.g. brake servo unit, power steering). Driving in this manner is a danger to yourself and others.

Pedals

To ensure the pedal travel is uninhibited, there must be no mats in the area of the pedals.

Starting and Operating

New Vehicle Run-In

Use the following precautions for the first few hundred kilometres (miles) to improve the performance and economy of your vehicle and add to its long life:

- Avoid full-throttle starts.
- Do not race the engine.
- Avoid hard stops except in emergencies. This will allow your brakes to bed in properly.
- Avoid quick starts, sudden accelerations, and prolonged high-speed driving in order to avoid damage to the engine and to conserve fuel.
- Avoid full-throttle acceleration in low gear.
- Do not tow any other vehicle.

Ignition Positions

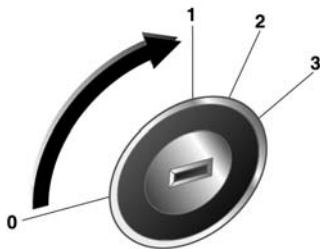

- 0 (LOCK) = Ignition off
1 (ACC) = Ignition off, steering wheel lock released
2 (ON) = Ignition on
3 (START) = Starting

Danger

Do not turn the key to 0 or 1 position while driving.

(Continued)

Danger (Continued)

Vehicle and brake assistance would not operate, causing vehicle damage, personal injury or possibly death.

Caution

Do not leave the key in 1 or 2 position for extended periods while the engine is not running. This will discharge the battery.

Starting the Engine

Starting engine with the ignition switch

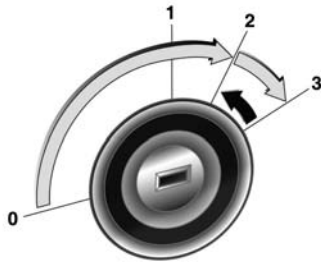

- Turn the key to position 1, move the steering wheel slightly to release the steering wheel lock
- Manual gearbox: operate clutch.
- Automatic transmission: Move gear lever to P or N.
- Do not operate accelerator pedal.

- Turn the key to position 3, depressing the clutch pedal and footbrake then release when engine is running.

Before restarting or to switch off the engine, turn key back to 0.

Caution

Do not operate starter motor for more than 10 seconds at a time.

If the engine does not start, wait 10 seconds before trying again.

This will prevent starter motor damage.

Parking

- Do not park the vehicle on an easily ignitable surface. The high temperature of the exhaust system could ignite the surface.
- Always apply parking brake without pressing release button. Apply as firmly as possible on downhill or uphill slopes.

Depress the foot brake at the same time to reduce operating force.

- Switch off the engine and ignition. Turn the steering wheel until the steering wheel lock engages.
 - If the vehicle is on a level surface or uphill slope, engage first gear before switching off the ignition. On an uphill slope, turn the front wheels away from the kerb.
- If the vehicle is on a downhill slope, engage reverse gear before switching off the ignition. Turn the front wheels towards the kerb.
- Lock the vehicle and activate the anti-theft alarm system.

Engine Exhaust

Danger

Engine exhaust gases contain poisonous carbon monoxide, which is colourless and odourless and could be fatal if inhaled.

If exhaust gases enter the interior of the vehicle, open the windows. Have the cause of the fault rectified by a workshop.

Avoid driving with an open load compartment, otherwise exhaust gases could enter the vehicle.

Catalytic Converter

The catalytic converter reduces the amount of harmful substances in the exhaust gas.

Caution

Fuel grades other than those listed on pages ⇨ *Fuel for Petrol Engines on page 9-16*, ⇨ *Engine Data on page 12-3* could damage the catalytic converter or electronic components.

Unburnt petrol will overheat and damage the catalytic converter. Therefore avoid excessive use of the starter, running the fuel tank dry and starting the engine by pushing or towing.

In the event of misfiring, uneven engine running, a reduction in engine performance or other unusual problems, have the cause of the fault rectified by a workshop as soon as possible. In an emergency, driving can be continued for a short period, keeping vehicle speed and engine speed low.

Automatic Transmission

The automatic transmission is an electronically controlled four-speed transmission.

Fourth gear is overdrive.

Starting the vehicle

1. After warming up the engine, continue to press the brake pedal while shifting the selector lever to either the R, D, 2 or 1 position.

Caution

Do not shift between D (Drive) and R (Reverse) or P (Park) while the vehicle is moving. This will cause damage to your transmission and personal injury.

2. Release the parking brake and the brake pedal.

- Slowly press the accelerator pedal to set the vehicle in motion.

Selector Lever

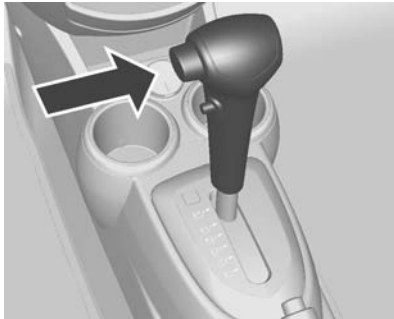

P (PARK): Locks the front wheels. Select P only when the vehicle is stationary and the parking brake is applied.

R (REVERSE): Select R only when the vehicle is stationary.

N (NEUTRAL): Neutral gear position.

D: This drive position is for all normal driving conditions. Allows the transmission to shift into all four forward gears. Fourth gear is overdrive which reduces engine speed and noise level while increasing fuel economy.

2: Allows the transmission to shift from 1st to 2nd gear and prevents automatic shifting into 3rd or 4th gear.

Select drive range 2 for more power when climbing hills and for engine braking when driving down steep hills.

1: This position locks the transmission in first gear.

Select 1 for maximum engine braking when driving down severe gradients.

Caution

Do not accelerate while engaging a gear.

(Continued)

Caution (Continued)

Never depress the accelerator pedal and brake pedal at the same time.

When a gear is engaged, the vehicle slowly begins to creep when the brake is released.

Do not use the P (Park) position in place of the parking brake.

Turn off the engine, apply the parking brake, and remove the ignition key when leaving the vehicle.

Never leave the vehicle unattended while the engine is running.

Shifting between gear positions

Movement between certain gear positions requires pressing the release button on the side of the selector lever.

9-6 Driving and Operating

Follow the descriptions as indicated by the arrows when shifting the selector lever.



P



Push the release button to shift. Arrows indicate shifts that do not require you to push the release button.



R



Depress the brake pedal and push release button to shift.



N



Shifts that require you to push the release button are indicated by arrows.



D



2



1





Shift freely.

Warning

To help prevent damage to the transmission, observe the following precautions:

Do not press the accelerator pedal while shifting from P or N to R, D, 2 or 1.

To do so may not only damage the transmission, but could cause you to lose control of the vehicle.

Use D as much as possible.

Never shift to P or R while the vehicle is in motion.

(Continued)

Warning (Continued)

When stopping the vehicle on an uphill gradient, do not hold the vehicle in place by pressing the accelerator pedal. Use the foot brake.

Press the brake pedal when shifting from P or N to R or a forward gear.

Otherwise transmission could be damaged or vehicle could move unexpectedly, causing driver to lose control of the vehicle, resulting in personal injury or damage to the vehicle or other property.

Engine braking

To help use the braking effect of engine compression when driving on a long downhill:

For automatic transmission, select the drive range "2" or "1" if necessary.

Engine braking is the most effective in drive range "1". If drive range "1" is selected at too high speed, the transmission remains in current gear until the vehicle slows down.

Select drive range "2" for ordinary engine braking effect. For even greater slowing ability, select "1".

Note: Use of engine compression during long mountainous descents may prolong the life of your brakes.

Rocking the vehicle

Rocking the vehicle is only permissible if the vehicle is stuck in sand, mud or snow.

Move the gear lever between D and R in a repeat pattern.

Do not race the engine and avoid sudden acceleration.

Parking

After stopping the vehicle by pressing the brake pedal, engage P and pull the lever up firmly and then remove ignition key.

9-8 Driving and Operating

Kickdown

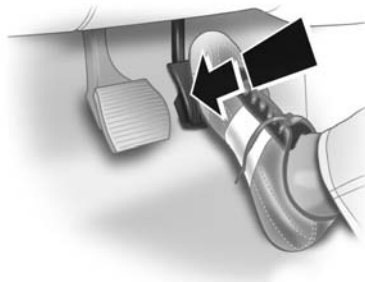

For faster acceleration press the accelerator pedal all the way down and hold. The transmission shifts to a lower gear depending on the engine speed.

Overdrive off

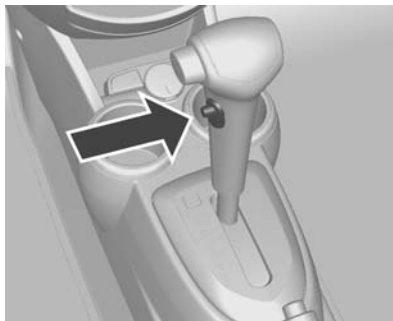

The fourth gear of your automatic transmission is an overdrive.

To cancel the overdrive function, press the overdrive button, and the O/ D OFF indicator in the warning tell-tale box will be ON.

The O/D OFF function can be used when undesirable shifting to fourth gear happens such as on a long uphill gradient.

Note: In normal driving conditions, drive with the overdrive function activated for fuel economy.

Fault

In the event of a fault, the malfunction indicator light or automatic transmission warning light illuminates. The transmission no longer shifts automatically nor manually because it is locked in a certain gear.

Have the cause of the fault remedied by a workshop.

Interruption of Power Supply

In the event of an interruption of power supply, the gear lever cannot be moved out of the P position.

If the battery is discharged, start the vehicle using jump leads.

If the battery is not the cause of the fault, release gear lever and remove ignition key from ignition lock.

Release gear lever

Your vehicle has a Brake-Transmission Shift Interlock (BTSI) system. Before shifting from park (P), the ignition must be ON and you must depress the brake pedal all the way down. If you cannot shift out of P with the ignition ON and the brake pedal depressed:

1. Turn the ignition off
2. Depress and hold the brake pedal and pull the handbrake up.

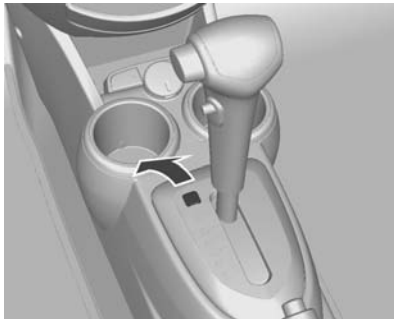

3. Open cover.

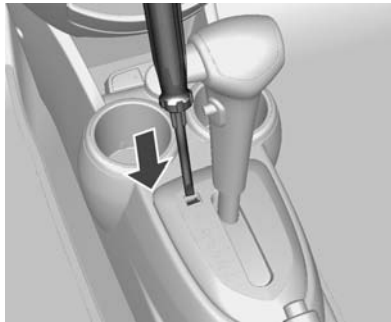

4. Insert a screwdriver into the opening as far as it will go and move the selector lever out of P. Start the engine and shift into the gear you want.

If P is engaged again, the selector lever will be locked in position again.

5. Close cover.
6. Have your vehicle repaired as soon as possible.

Manual Gearbox

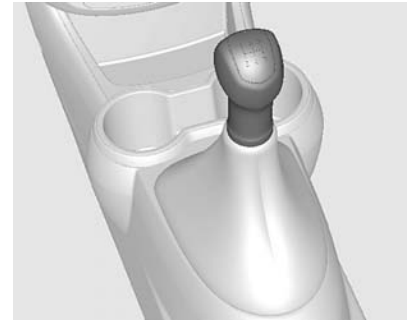

If the gear does not engage, set the lever in neutral, release the clutch pedal and depress again; then repeat gear selection.

Do not ride the clutch unnecessarily. When operating, depress the clutch pedal completely. Do not use the pedal as a foot rest.

Caution

It is not advisable to drive with the hand resting on the selector lever.

9-10 Driving and Operating

Engine braking

For manual gearbox, downshift to a lower gear in a sequential order.

Warning

Do not downshift your manual gearbox by two or more gear positions at a time.

This prevents damage to your transmission or loss of control and personal injuries.

Note: Use of engine compression during long mountainous descents may prolong the life of your brakes.

Brakes

The brake system comprises two independent brake circuits.

If a brake circuit fails, the vehicle can still be braked using the other brake circuit. However, braking effect is achieved only when the brake pedal is depressed firmly. Considerably more force is needed for this. The braking distance is extended. Seek the assistance of a workshop before continuing your journey.

Caution

If one of the circuits fails, the brake pedal must be pressed with greater pressure and the braking distance may be increased. Have the brake system checked and repaired by a workshop immediately. We recommend that you consult your authorised workshop.

(Continued)

Caution (Continued)

If the brake pedal can be pressed further than normal, the brakes may be in need of repair.

Consult a workshop immediately. We recommend that you consult your authorised workshop.

Caution

Do not drive with your foot resting on the brake pedal. To do so will accelerate wear of the brake components. The brakes may also become overheated, resulting in longer braking distance and an unsafe condition.

 **Warning**

After driving through deep water, washing the vehicle, or using the brakes excessively when going down a steep hill, the brakes can temporarily lose their stopping power. This may be due to wet brake components or overheating.

If your brakes temporarily lose their stopping power because of overheating: Shift to a lower gear when going down hills. Do not continuously apply the brakes.

If your brakes temporarily lose their power because of wet brake components, the following procedure will help restore their normal performance:

1. Check behind you for other vehicles.

(Continued)

Warning (Continued)

2. Keep a safe forward speed with plenty of space to your rear and sides.
3. Gently apply the brakes until normal performance is restored.

Antilock Brake System (ABS)

Anti-lock brake system (ABS) prevents the wheels from locking.

ABS starts to regulate brake pressure as soon as a wheel shows a tendency to lock. The vehicle remains steerable, even during hard braking.

ABS control is made apparent through a pulse in the brake pedal and the noise of the regulation process.

For optimum braking, keep the brake pedal fully depressed throughout the braking process,

despite the fact that the pedal is pulsating. Do not reduce the pressure on the pedal.

Do not decrease your power when pressing the brake pedal.

When you start the vehicle after the ignition is switched on, a mechanical sound can be heard once. This is normal and shows that the ABS is ready to operate.

Control indicator  ⇨ *Antilock Brake System (ABS) on page 9-11.*

Fault **Warning**

If there is a fault in the ABS, the wheels may be liable to lock due to braking that is heavier than normal. The advantages of ABS are no longer available. During hard braking, the vehicle can no longer be steered and may swerve.

9-12 Driving and Operating

Have the cause of the fault remedied by a workshop.

Parking Brake

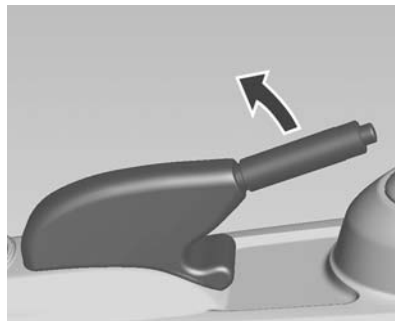
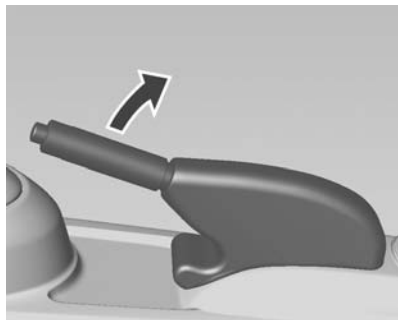

Always apply parking brake firmly without operating the release button, and apply as firmly as possible on a downhill or uphill slope.

To release the parking brake, pull the lever up slightly, press the release button and fully lower the lever.

To reduce the operating forces of the parking brake, depress the foot brake at the same time.

Brake Assist

If the brake pedal is depressed quickly and forcefully, maximum brake force is automatically applied (full braking).

Maintain continuous pressure on the brake pedal for as long as full braking is required. Maximum brake force is automatically reduced when the brake pedal is released.

Ride Control Systems

Electronic Stability Control (ESC)

Electronic Stability Control (ESC) improves driving stability when necessary, regardless of the type of road surface or tyre grip. It also prevents the driving wheels from spinning.

As soon as the vehicle starts to swerve (understeer/oversteer), the engine output is reduced and the wheels are braked individually. This considerably improves the driving stability of the vehicle on slippery road surfaces.



ESC is operational as soon as the control indicator  extinguishes.

When ESC is active  flashes.

Warning

Do not let this special safety feature tempt you into taking risks when driving.

Adapt speed to the road conditions.

Control indicator   *Electronic Stability Control (ESC) Indicator Light on page 5-18*

Deactivation



For very high-performance driving ESC can be deactivated by pressing the  button.

Control indicator  illuminates.

ESC is reactivated by pressing the  button again.

ESC is also reactivated the next time the ignition is switched on.

When the ESC system is actively improving the stability of the vehicle, reduce speed and pay extra attention to the road condition. The ESC system is only a supplementary device for the vehicle. When the vehicle exceeds its physical limits, it can no longer be controlled. Therefore do not rely on this system. Keep driving safely.

Object Detection Systems

Parking Assist

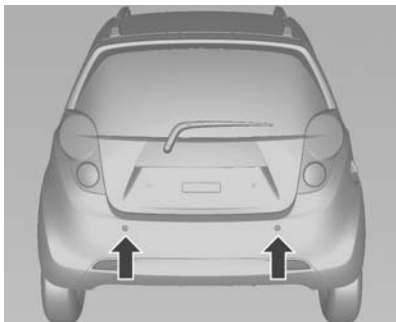

The parking assist system assists the driver during backward movement of the vehicle by chiming if any object is sensed behind the vehicle.

This system can be turned on automatically whenever the ignition switch is ON and the transaxle's selector lever is in R.

This system is deactivated when the vehicle's speed is greater than approximately 5 km/h (3 mph).

If the alarm sounds when shifting the gear to R position, this indicates normal condition.

At this time, you can figure out the distance between your vehicle and obstacles with the alarming sound.

However, do not confuse with the sound that continues when the obstacles are within 40 cm (16 inches).

Caution

If the following happens, this indicates that there is a malfunction in the parking assist system. The alarm sounds 3 times continuously when there are no obstacles around the rear bumper. Consult a workshop as soon as possible. We recommend your authorised workshop.

Alarm and sensing distance	Alarm
1st Alarm approx. 0.8~1.5 m (30~60 inches) from the rear bumper	-beep- beep-
2nd Alarm approx. within 80 cm (60 inches) from the rear bumper	-beep beep beep beep
3rd Alarm approx. 20~40 cm (8~16 inches) from the rear bumper	Alarm stays on

Caution

The parking assist system should only be considered as a supplementary function. The driver must check the rear.

(Continued)

Caution (Continued)

The audible warning signal can be different depending on the objects.

The audible warning signal might not activate in case the sensor is frozen or stained with dirt or mud.

Do not push or scratch the surface of the sensor. This will likely damage the covering.

There is a chance of malfunction of the parking assist system when driving on uneven surfaces such as woods, gravel roads, jagged roads or slopes.

The parking assist system might not recognise sharp objects, thick winter clothes or other thick and soft materials could absorb the frequency.

 **Caution**

When receiving other ultrasonic signals (metal sound or air braking noises from heavy commercial vehicles), the parking assist system may not work properly.

Clean dirty sensors with a soft sponge and clean water.

Such objects may not be detected by the system at very close range (approximately 25 cm) and distance within approximately 1m.

You should continue to keep watching the mirrors or turning your head backwards. Normal precautions when reversing should be maintained. Do not press or shock the sensors by hitting or high-pressure water gun while washing, or the sensors will be damaged.

 **Caution**

The upper portion of the vehicle can be hit before sensor operation, so check with outside rearview mirrors or by turning your head during parking.

The parking assist system will be operated correctly on vertically flat surfaces.

Fuel

Fuel for Petrol Engines

Only use unleaded fuel that complies with EN 228.

Usage of fuel with quality, not complying to the Technical Regulations in effect (Decree № 118 of 27.02.2008 with amendments of 30.12.2008 № 1076) can lead to engine damage and loss of all warranty obligations.

Equivalent standardised fuels with an ethanol content of max. 10% by volume may be used.

Use fuel with the recommended octane rating ⇨ *Engine Data on page 12-3*. Use of fuel with too low an octane rating can reduce engine power and torque and slightly increases fuel consumption.

Caution

Use of fuel that does not comply to EN 228 or E DIN 51626-1 or equivalent can lead to deposits or engine damage and may affect your warranty.

Caution

Use of fuel with too low an octane rating could lead to uncontrolled combustion and engine damage.

Filling the Tank

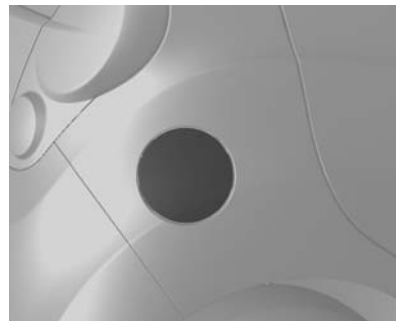

Caution

If you use inappropriate grade fuel or put incorrect fuel additives into the fuel tank, the engine and catalytic converter may be seriously damaged.

Be sure to use the correct fuel (petrol or diesel) corresponding to your vehicle when refuelling.

(Continued)

Caution (Continued)

If you fill Diesel in your petrol powered vehicle, your vehicle can be seriously damaged.

For safety reasons, fuel containers, pumps and hoses must be properly earthed. Static electricity can ignite the petrol vapour. You can be burned and your vehicle damaged.

 **Danger**

Before refuelling, switch off engine and any external heaters with combustion chambers. Switch off any mobile phones.

Electromagnetic waves or currency of mobile phones could ignite fuel vapours.

(Continued)

Danger (Continued)

Fuel is flammable and explosive. No smoking. No naked flames or sparks. Follow the operating and safety instructions of the filling station when refuelling.

Remove static electricity on your hands by touching something able to release static electricity when touching or opening fuel cap or refuelling nozzle.

Don't do any actions generating static electricity like getting on and off vehicle when refuelling. Static electricity could ignite fuel vapours.

If you can smell fuel in your vehicle, have the cause of this remedied immediately by a workshop.



1. Stop the engine.

9-18 Driving and Operating

2. Pull up the fuel filler door release lever located on the floor, left front side of driver's seat.

Pull up the fuel filler door release lever located on the floor, right front side of driver's seat.

3. Turn the fuel filler cap anticlockwise slowly. If a hissing sound is heard, wait for it to stop before completely unscrewing the cap. The fuel filler door is in the right rear quarter panel.

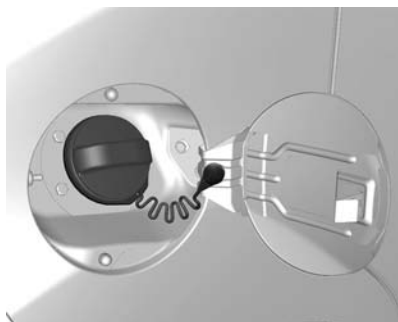

4. Remove the cap. The cap is tethered to the vehicle.

5. After refuelling, replace cap. Turn it clockwise until you hear several clicks.

6. Push the fuel filler door closed until it latches.

Note: If, in cold weather, the fuel filler door does not open, tap the door lightly. Then try to open it again.

Caution

Wipe off any overflowing fuel immediately.

Fuel Consumption - CO₂-Emissions

The fuel consumption (combined) for the Spark model is within a range of 4.8 to 6.3 l/100km.

The fuel consumption (combined) for the Spark model is within a range of 5.4 to 6.3 l/100 km.

The fuel consumption (combined) for the Spark model is within a range of 49 to 37 mpg.

The CO₂ emission (combined) is within a range of 113 to 119 g/km.

The CO₂ emission (combined) is within a range of 129 to 149 g/km.

For the values specific for your vehicle, refer to the EEC Certificate of Conformity provided with your vehicle or other national registration documents.

General information

The official fuel consumption and specific CO₂ emission figures quoted relate to the EU base model with standard equipment.

Fuel consumption data and CO₂ emission data are determined according to regulation R (EC) No. 715/2007 (in the version respectively applicable), taking into consideration the vehicle weight in running order, as specified by the regulation.

The figures are provided only for the purpose of comparison between different vehicle variants and must not be taken as a guarantee for the actual fuel consumption of a particular vehicle. Additional equipment may result in slightly higher results than the stated consumption and CO2 figures.

Furthermore, fuel consumption is dependent on personal driving style as well as road and traffic conditions.

Vehicle Care

General Information

Accessories and Modifications	10-2
Vehicle Storage	10-2
End-of-Life Vehicle Recovery	10-3

Vehicle Checks

Doing Your Own Service Work	10-3
Bonnet	10-3
Engine Compartment Overview	10-6
Engine Oil	10-9
Automatic Transmission Fluid	10-10
Engine Air Cleaner/Filter	10-12
Engine Coolant	10-12
Power Steering Fluid	10-14
Washer Fluid	10-15
Brake Fluid	10-15
Battery	10-17
Wiper Blade Replacement	10-18

Bulb Replacement

Bulb Replacement	10-19
Headlamps	10-19
Taillights	10-21
Side Indicator Lamps	10-22
Centre High-Mounted Brake lamp (CHMBL)	10-23
Number Plate Lamp	10-23
Interior Lamps	10-23

Electrical System

Fuses	10-24
Engine Compartment Fuse Block	10-25
Instrument Panel Fuse Block	10-27

Vehicle Tools

Tools	10-30
-------------	-------

Wheels and Tyres

Wheels and Tyres	10-30
Winter Tyres	10-30
Tyre Designations	10-30
Tyre Pressure	10-31
Tyre Pressure Monitor System	10-32

Tyre Pressure Monitor Operation	10-33
Tread Depth	10-37
Tyre Rotation	10-37
Different Size Tyres and Wheels	10-38
Wheel Covers	10-38
Wheel Alignment and Tyre Balance	10-39
Wheel Replacement	10-39
Tyre Chains	10-42
Tyre Repair Kit	10-43
Compact Spare Tyre	10-46
Full-Size Spare Tyre	10-47

Jump Starting

Jump Starting	10-48
---------------------	-------

Towing the Vehicle

Towing the Vehicle	10-49
Towing Another Vehicle	10-52

Appearance Care

Exterior Care	10-53
Interior Care	10-55

General Information

Accessories and Modifications

We recommend to use genuine Parts and Accessories and factory approved parts specific for your vehicle type. We cannot assess or guarantee reliability of other products - even if they have a regulatory or otherwise granted approval.

Do not make any modifications to the electrical system, e.g. changes of electronic control units (chip tuning).

 Caution
Never modify your vehicle. It may affect the performance, durability and safety of the vehicle and the warrant may not cover any problems caused by the modification.

Vehicle Storage

Storage for a long period of time

Following must be done if the vehicle should be stored for several months:

- Wash and wax the vehicle.
- Have the wax in the engine compartment and underbody checked.
- Fill up fuel tank completely.
- Clean and preserve rubber seals.
- Change engine oil.
- Drain washer fluid reservoir.
- Check coolant antifreeze and corrosion protection.
- Adjust tyre pressure to the value specified for full load.
- Park vehicle in dry, well ventilated place. Engage first or reverse gear. Prevent the vehicle from rolling.

- Do not apply the parking brake.
- Open bonnet, close all doors and lock the vehicle.
- Disconnect the clamp from the negative terminal of the vehicle battery. Beware that all systems are not functional, e.g. anti-theft alarm system.
- Close the bonnet.

Putting back into operation

When the vehicle is to be put back into operation:

- Connect the clamp to the negative terminal of the vehicle battery. Activate the electronics of the power windows.
- Check tyre pressure.
- Fill up the washer fluid reservoir.
- Check the engine oil level.
- Check the coolant level.
- Fit the number plate if necessary.

End-of-Life Vehicle Recovery

Information on end-of-life vehicle recovery centres and the recycling of end-of-life vehicles is available on our website. Only entrust this work to an authorised recycling centre.

Vehicle Checks

Doing Your Own Service Work

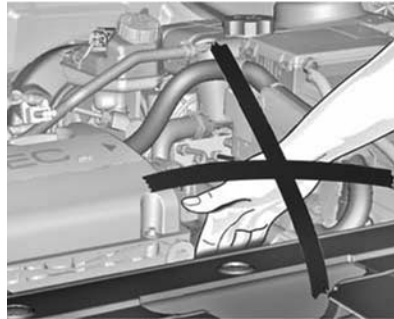

Warning

Only perform engine compartment checks when the ignition is off.

The cooling fan may start operating even if the ignition is off.

Danger

The ignition system uses extremely high voltage. Do not touch.

Bonnet

Opening

Type 1



10-4 Vehicle Care

Type 2



1. Pull the release lever and return it to its original position.

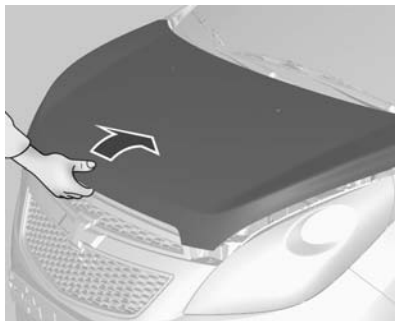

2. Push the safety catch up and open the bonnet.

Warning

Only touch the foam padding of the bonnet support rod handle when the engine is hot.

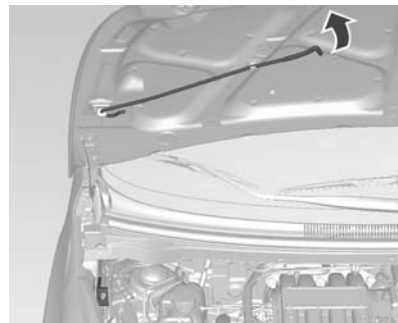

3. Pull up the support rod lightly from the holder. And then secure it at the left side hook of the engine compartment.

Closing

Before closing the bonnet, press the support into the holder.

Lower the bonnet and allow it to drop into the catch. Check that the bonnet is engaged.

 **Warning**

Always observe the following precautions: Pull on the front edge of the bonnet to make sure it is latched securely before you drive your vehicle.

Do not pull the bonnet release handle while your vehicle is moving.

Do not move your vehicle with the bonnet open. An open bonnet will obscure the driver's vision.

Operating your vehicle with the bonnet open can lead to a collision resulting in damage to your vehicle, to other property, personal injury or even death.

Engine Compartment Overview (Petrol engine)

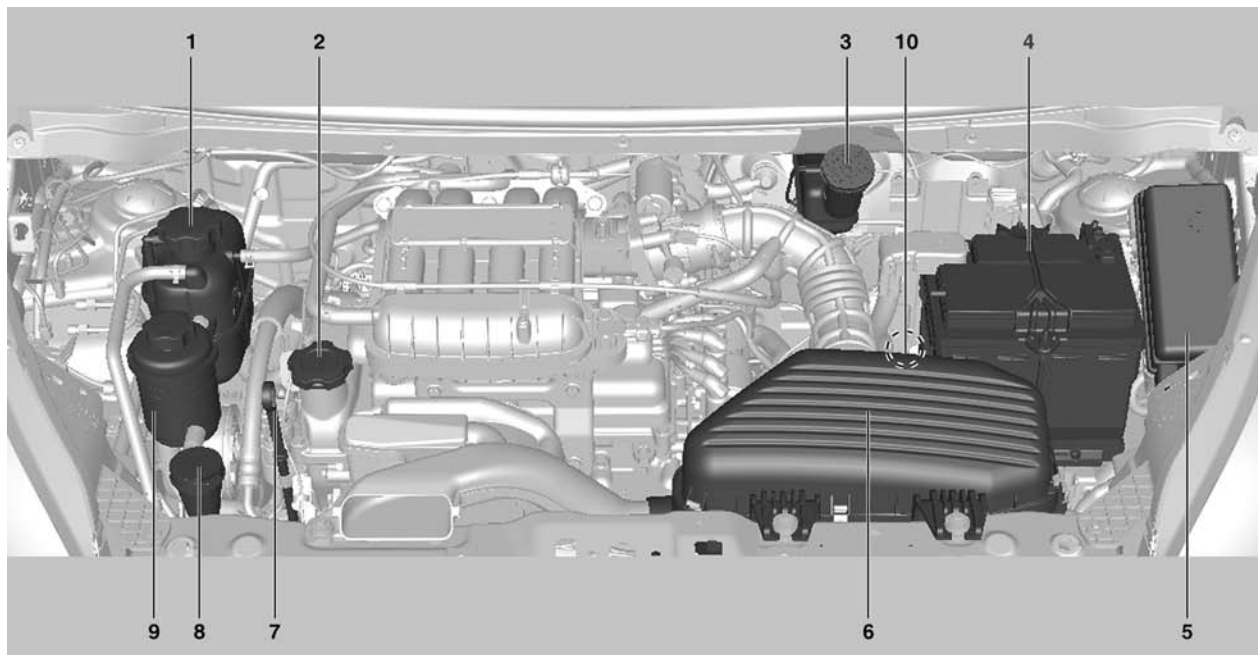

<Type 1>

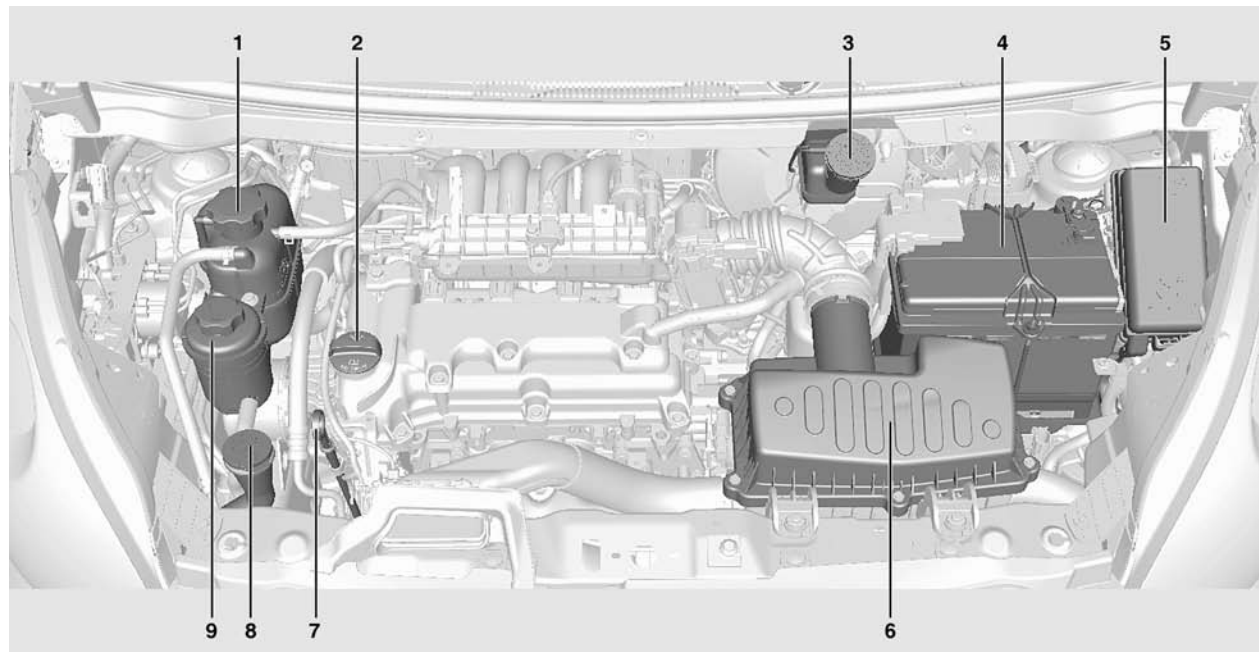

<Type 2>

10-8 Vehicle Care

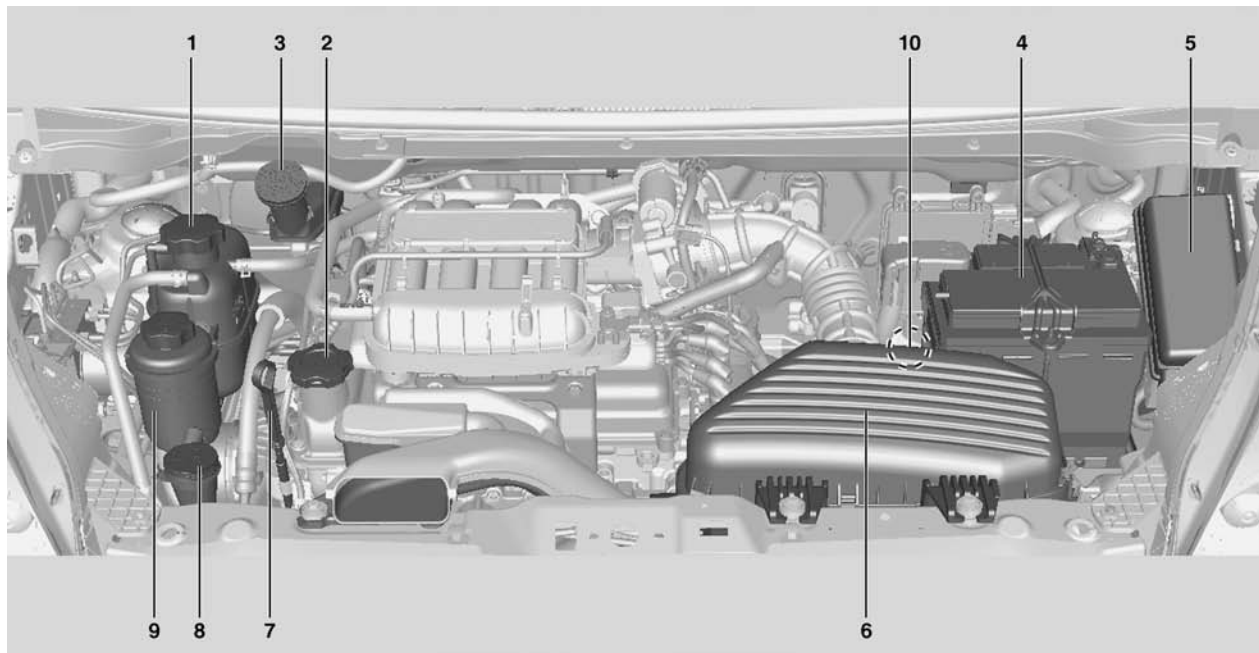

1. Engine coolant container
2. Engine oil cap
3. Brake fluid container
4. Battery
5. Fuse block
6. Engine air filter
7. Dipstick for engine oil level
8. Washer fluid container
9. Power steering fluid container
10. Automatic gearbox fluid level dipstick

Engine Oil

It is advisable to check the engine oil level manually before embarking on a long journey.

Check with the vehicle on a level surface. The engine must be at operating temperature and switched off for at least 5 minutes.

Pull out the dipstick, wipe it clean, insert it to the stop on the handle, pull out and read the engine oil level.

Insert dipstick to the stop on the handle and make half a turn.

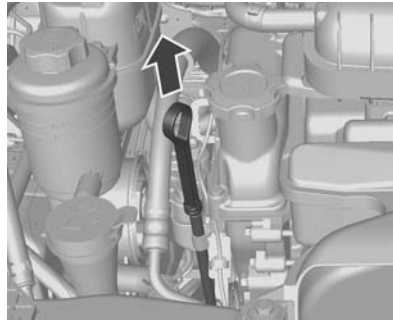

When the engine oil level has dropped to the MIN mark, top up engine oil.

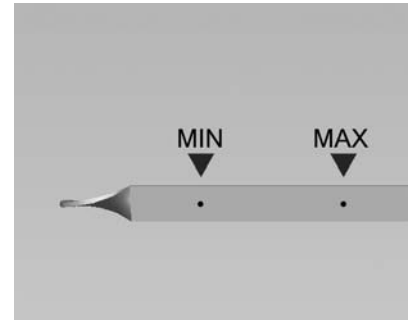

We recommend the use of the same grade of engine oil that was used at last change.

The engine oil level must not exceed the MAX mark on the dipstick.

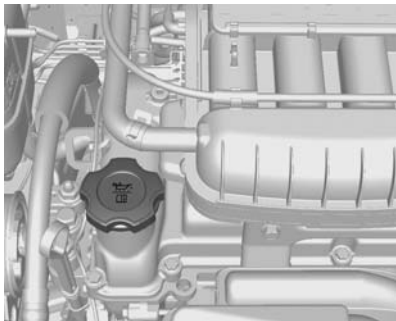

The engine oil filler cap is located on the camshaft cover.

Caution

Overfilled engine oil must be drained or suctioned out.

Capacities and Viscosity ⇨
Capacities and Specifications on page 12-8 ⇨ *Recommended Fluids and Lubricants on page 11-7.*

Warning

Engine oil is an irritant and, if ingested, can cause illness or death.

Keep out of reach of children.

Avoid repeated or prolonged contact with skin.

Wash exposed areas with soap and water or hand cleaner.

Be very careful when draining the engine oil as it may be hot enough to burn you!

Automatic Transmission Fluid

To ensure proper functioning, efficiency, and durability of the automatic transmission, be sure to keep the gearbox fluid at the proper level. Too much or too little fluid can cause problems.

The fluid level must be checked with the engine running and the selector lever in P (Park). The vehicle must be up to normal operating temperature and parked on level ground.

The normal operating temperature for the fluid (70°C ~ 80°C) will be reached after driving.

Checking automatic gearbox fluid level

If the fluid is contaminated or discoloured after inspection, change the automatic gearbox fluid. Use only the fluid specified in the fluid chart in this manual.

Decrease in the fluid level indicates a leak in the automatic transmission. If noted, consult a workshop to repair the problem as soon as possible. We recommend your authorised workshop.

⚠ Caution

Take care not to let dirt or foreign materials contaminate the gearbox fluid.

Contaminated fluid can cause a severe malfunction of the automatic transmission, leading to costly repairs.

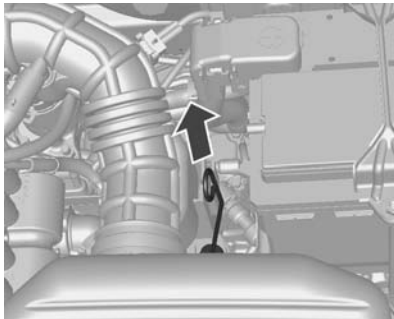

1. Start the engine.

2. Warm up until the temperature of the automatic gearbox fluid reaches approximately 70°C ~ 80°C.
3. Move the selector lever from "P" to "1" and return to "P". Wait a few seconds at each selected position until the selected gears are fully engaged.
4. Pull out the dipstick and wipe it clean.
5. Re-insert the dipstick completely. At this time, it should not contact with any other parts.
6. Pull the dipstick out again.
7. Check the oil on the dipstick to make sure it is not contaminated.

⚠ Caution

Re-insert the dipstick completely. At this time, it should not contact with any other parts.

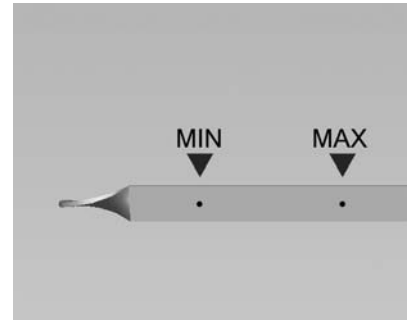

8. Check the oil level. Oil should be between MIN and MAX mark on the dipstick as shown in the illustration.
9. If the oil level is below MIN, add enough ATF to raise the oil level to MAX. Do not fill over MAX mark.

⚠ Caution

Too much fluid will decrease vehicle performance.

(Continued)

Caution (Continued)

Do not overfill the automatic gearbox fluid.

This can damage the transmission.

Engine Air Cleaner/Filter

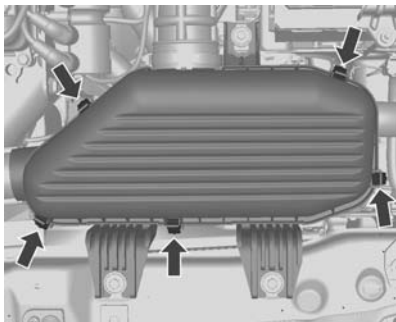

Type 1

1. Loosen the air filter cover attaching clips and open the cover.
2. Replace the air filter.

3. Lock the cover with the cover attaching clips.

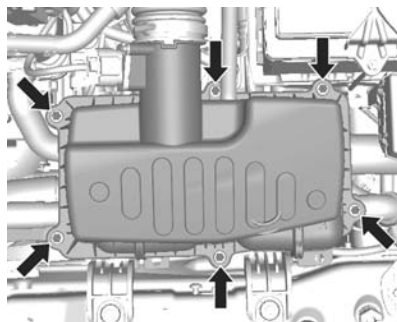

Type 2

1. Remove the screws and lift off the cover.
2. Inspect or replace the engine air cleaner/filter.
3. Put the cover back on tightly and tighten the screws.

Caution

The engine needs clean air to operate properly.

Do not operate your vehicle without the air filter element installed.

Driving without the air filter element properly installed can damage your engine.

Engine Coolant

In countries with moderate climate the coolant provides freeze protection down to approx. -35°C .

In countries with cold climate the coolant provides freeze protection down to approx. -50°C .

Maintain a sufficient concentration of anti-freeze.

Caution

Only use approved anti-freeze.

Coolant level

⚠ Caution

Too low a coolant level can cause engine damage.

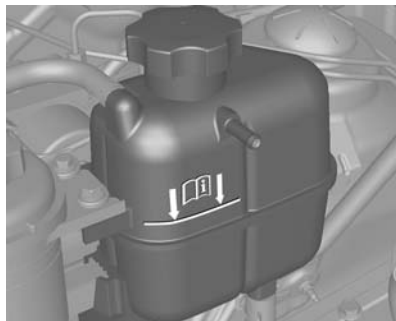

If the cooling system is cold, the coolant level should be above the filling line mark. Top up if the level is low.

⚠ Warning

Allow the engine to cool before opening the cap. Carefully open the cap, relieving the pressure slowly.

Fill up with a mixture of demineralised water and anti-freeze approved for the vehicle. Install the cap tightly. Have the anti-freeze concentration checked and have the cause of the coolant loss remedied by a workshop.

Note: If the coolant level falls below the line mark, refill the radiator with 50/50 mix of de-mineralised water and phosphate anti-freeze.

In order to protect your vehicle in extremely cold weather, use a mix of 40 percent water and 60 percent anti-freeze.

⚠ Caution

Plain water or the wrong mixture can damage the cooling system.

Do not use plain water, alcohol or methanol anti-freeze in coolant system.

The engine may overheat or even catch fire.

⚠ Caution

Coolant can be hazardous material.

Avoid repeated or prolonged contact with coolant.

Clean your skin and nails with soap and water after coming in contact with coolant.

Keep out of reach of children.

(Continued)

Caution (Continued)

Coolant can irritate the skin and can cause illness or death if swallowed.

Caution

It is not needed to add coolant more frequently than the recommended interval.

If you are adding coolant often, this may be a sign that your engine needs maintenance.

We recommend that you consult your authorised workshop.

Power Steering Fluid

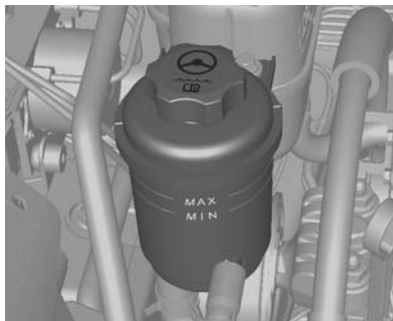

Open the cap and remove it.

The power steering fluid level must be between the MIN and the MAX marks.

Fill up if the level is low.

Caution

Extremely small amounts of contamination can cause steering system damage and cause it to

(Continued)

Caution (Continued)

not work properly. Do not allow contaminants to contact the fluid side of the reservoir cap/dipstick or from entering the reservoir.

Caution

Do not operate vehicle without the required amount of power steering fluid.

To do so can damage the power steering system of your vehicle, leading to costly repairs.

Warning

An overflow of the fluid may cause the fluid to burn or discolour paintwork.

Do not overfill the reservoir.

(Continued)

Warning (Continued)

An engine fire can cause personal injuries and damage your vehicle and other property.

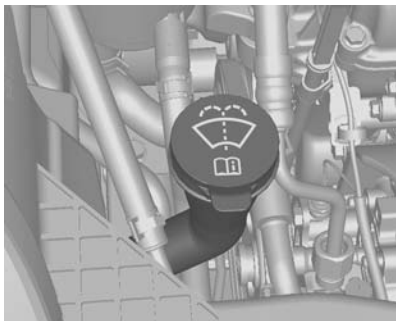
Washer Fluid

Fill with clean water mixed with a suitable quantity of washer fluid which contains antifreeze. For the correct mixing ratio refer to the washer fluid container.

Caution

Only washer fluid with a sufficient antifreeze concentration provides protection at low temperatures or a sudden drop in temperature.

To refill windscreen washer fluid reservoir:

- Use only commercially available ready-to-use washer fluid for that purpose.
- Do not use tap water. Minerals present in tap water may plug the windscreen washer lines.
- If air temperature is likely to go below the freezing point, use washer fluid which has sufficient anti-freezing property.

Brake Fluid**Warning**

Brake fluid is poisonous and corrosive. Avoid contact with eyes, skin, fabrics and painted surfaces.



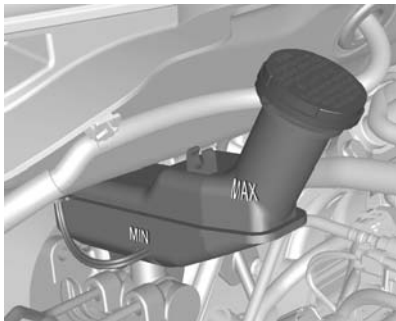

The brake fluid level must be between the MIN and the MAX marks.

When topping up, ensure maximum cleanliness as contamination of the brake fluid can lead to brake system malfunctions. Have the cause of the loss of brake fluid remedied by a workshop.

Only use brake fluid approved for the vehicle, Brake and clutch fluid
↪ *Recommended Fluids and Lubricants on page 11-7.*

⚠ Caution

Make sure you thoroughly clean around the brake fluid reservoir cap before removing the cap.

Contamination of the brake fluid system can affect system performance, leading to costly repairs.

An overflow of brake fluid on the engine may cause the fluid to burn.

Do not overfill the reservoir.

An engine fire can cause personal injuries and damage your vehicle and other property.

⚠ Caution

Using low quality brake fluid may cause corrosion to internal components of the brake system,
(Continued)

Caution (Continued)

which may result in decreased brake system performance, which is a safety concern. Always use high quality brake fluid approved for your vehicle model. We recommend GM genuine brake fluid.

⚠ Caution

Do not dispose of used brake fluid with your household waste. Use your local, authorised waste management facility.

Used brake fluid and their containers are hazardous. They can damage your health and the environment.

Brake fluid is harsh and can irritate skin and eyes.

(Continued)

Caution (Continued)

Do not allow the brake fluid to contact your skin or eyes. If it does, immediately wash the affected area thoroughly with soap and water or hand cleaner.

Battery

The vehicle contains a lead-acid battery. The vehicle battery is maintenance-free provided that the driving profile allows sufficient charging of the battery. Short distance driving and frequent engine starts can discharge the battery. Avoid the use of unnecessary electrical consumers.



Batteries do not belong in household waste. They must be disposed of at an appropriate recycling collection point.

Laying up the vehicle for more than 4 weeks can lead to battery discharge. Disconnect the clamp from the negative terminal of the vehicle battery.

Ensure the ignition is switched off before connecting or disconnecting the vehicle battery.

Warning

Keep glowing materials away from the battery to avoid explosion. Battery explosion can result in damage to the vehicle and serious injury or death.

Avoid contact with eyes, skin, fabrics and painted surfaces. The fluid contains sulphuric acid which can cause injuries and damage in the event of direct contact. In

(Continued)

Warning (Continued)

case of skin contact, clean the area with water and seek medical help immediately.

Keep out of reach of children.

Do not tilt an open battery.

Vehicle battery discharge protection
 ⇨ *Battery Power Protection on page 6-5.*



Meaning of symbols:

- No sparks, naked flames or smoking.
- Always shield eyes. Explosive gases can cause blindness or injury.
- Keep the battery out of reach of children.
- The battery contains sulphuric acid which could cause blindness or serious burn injuries.
- See the Owner's Manual for further information.
- Explosive gas may be present in the vicinity of the battery.

Wiper Blade Replacement

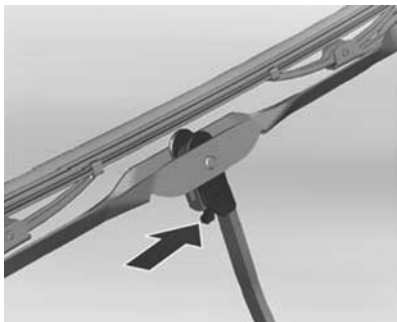

Lift wiper arm. Press release lever and detach wiper blade.

Properly functioning windscreen wipers are essential for clear vision and safe driving. Regularly check the condition of the wiper blades. Replace hard, brittle or cracked blades or those that smear dirt on the windscreen.

Foreign material on the windscreen or wiper blades can reduce the effectiveness of the wipers. If the blades are not wiping properly,

clean both the windscreen and the blades with a good cleaner or mild detergent. Rinse them thoroughly with water.

Repeat the process, if necessary. There is no way to remove traces of silicone from glass. Therefore, never apply polish with silicone to your vehicle's windscreen or you will get streaks which will impair the driver's vision.

Do not use solvents, petrol, kerosene, or paint thinner to clean wipers. These are harsh and can damage the blades and painted surfaces.

Bulb Replacement

Switch off the ignition and switch off the relevant switch or close the doors.

Only hold a new bulb at the base! Do not touch the bulb glass with bare hands.

Use only the same bulb type for replacement.

Replace headlamp bulbs from within the engine compartment.

Note: After driving in heavy rain or after washing, some exterior light lenses could appear frosty.

This condition is caused by the temperature difference between the inside and outside of the light. This is similar to the condensation on your windows inside your vehicle during rain and doesn't indicate a problem with your vehicle.

If the water leaks into the light bulb circuitry, have the vehicle checked by your authorised workshop.

Headlamps

Dipped beam and main beam

1. Detach plug connector from bulb.

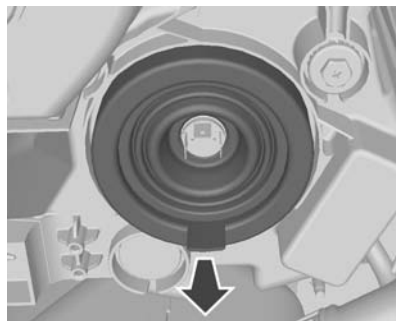

2. Remove protective cover.

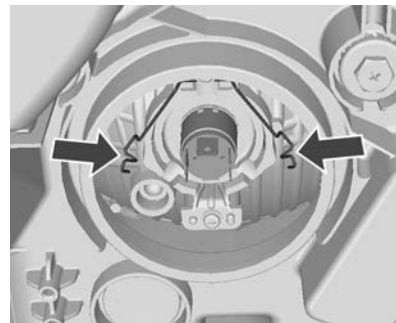

3. Press spring clip, disengage it.

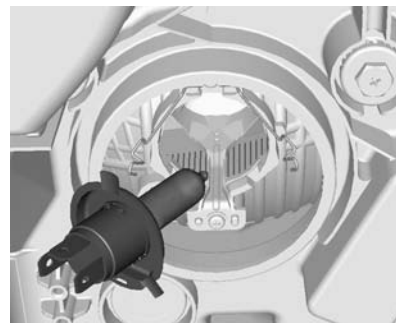

4. Remove bulb from reflector housing.

10-20 Vehicle Care

- When fitting a new bulb, engage the lugs in the recesses on the reflector.
- Engage the spring clip.
- Place headlight protective cover in position and close.
- Plug connector onto bulb.

Headlight aiming

The dipped beam headlight aiming can be adjusted with the screw located above the headlight.

Caution

If the headlights need to be re-aimed, it is recommended that the vehicle is taken to your authorised workshop for service, because it is related with safety.

Parking lights

- Detach plug connector from bulb.

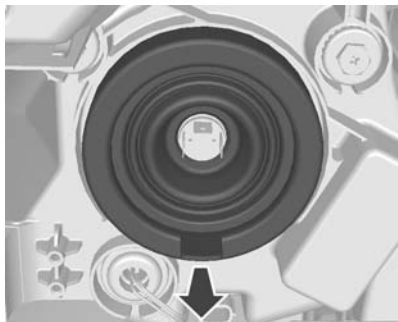

- Remove protective cover.



- Remove side light bulb holder from reflector.



- Remove bulb from socket.
- Insert new bulb.
- Insert holder in reflector.
- Place headlight protective cover in position and close.
- Plug connector onto bulb.

Fog lights

Have bulbs replaced by a workshop.

Fog light aiming

The fog light aiming can be adjusted with the screw located above the fog light.

⚠ Caution

If the fog lights need to be re-aimed, it is recommended that the vehicle is taken to your authorised workshop for service, because it is related with safety.

Front indicator lights

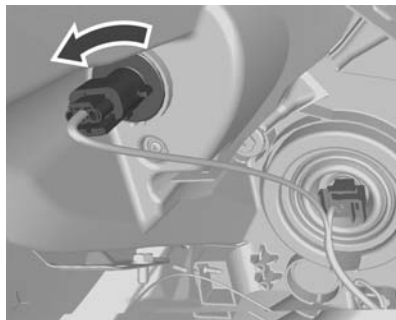

1. Rotate bulb holder anti-clockwise and disengage.

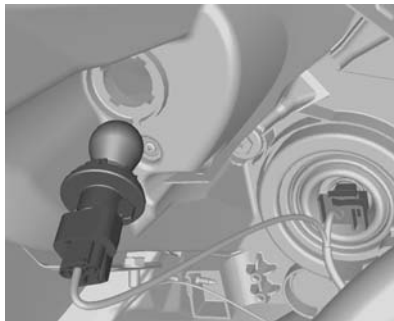

2. Push bulb into socket slightly, rotate anti-clockwise, remove and renew bulb.
3. Insert bulb holder in reflector, rotate clockwise to engage.

Taillights

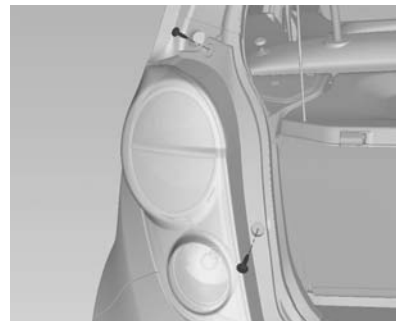

1. Unscrew both screws.
2. Remove tail light assembly. Take care that the cable duct remains in position.

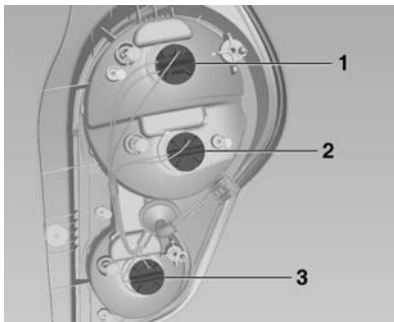

3. Tail light/brake light (1)
Indicator light (2)
Reverse light (passenger's side)
/ Rear fog light (Driver's side) (3)

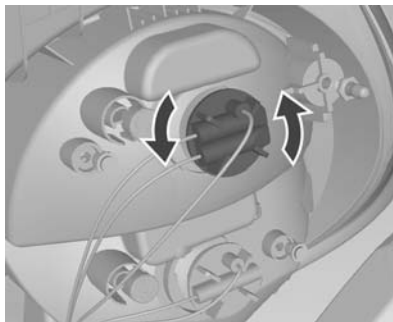

4. Rotate bulb holder anticlockwise.

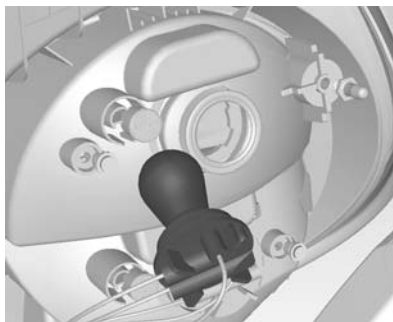

5. Remove bulb holder. Push bulb into socket slightly, rotate anticlockwise, remove and renew bulb.
6. Insert bulb holder into the tail light assembly and screw into place. Connect wiring plug. Install tail light assembly in body and tighten screws. Close covers and engage.
7. Switch on ignition, operate and check all lights.

Side Indicator Lamps

1. Push light towards the back of the vehicle and remove.
2. Rotate bulb holder anticlockwise.
3. Pull bulb out of the bulb holder and renew.
4. Reinstall in reverse order.

Centre High-Mounted Brake lamp (CHMBL)

<Bulb type>

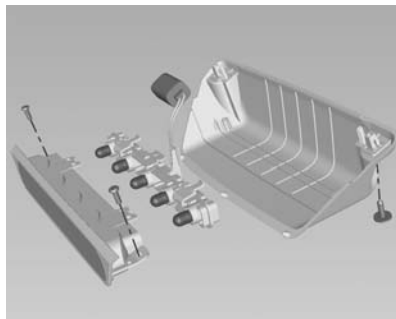

1. Open the tailgate.
2. Remove the two screws and the lamp housing. Disconnect the wiring harness connector before removing the lamp housing.
3. Remove the two screws and the reflector assembly.
4. Remove the bulb by pulling it straight out of the bulb holder.

5. Install a new bulb.
6. Reinstall the lamp housing.

<LED type>

Have bulbs replaced by a workshop.

Number Plate Lamp

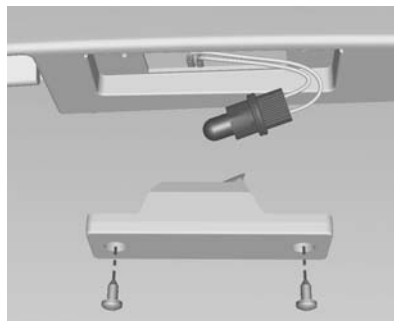

1. Unscrew both screws.
2. Remove bulb housing downward, taking care not to pull on the cable.

Rotate bulb holder anticlockwise to disengage.

3. Remove bulb from holder and renew bulb.
4. Insert bulb holder in bulb housing and rotate clockwise.
5. Insert bulb housing and secure using a screwdriver.

Interior Lamps

Courtesy lights

1. To remove it, prise the opposite side of the light switch using a flat-blade screwdriver. (Be careful not to make scratches.)
2. Remove the bulb.
3. Replace the bulb.
4. Reinstall the light assembly.

Load compartment light

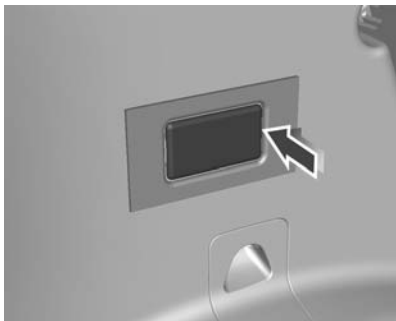

1. Prise the lamp out with a screwdriver.

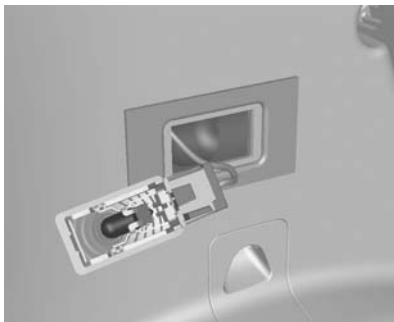

2. Remove bulb.
3. Insert new bulb.
4. Install lamp.

Electrical System

Fuses

Data on the replacement fuse must match the data on the defective fuse.

In a box above the positive terminal of the battery are some main fuses. If necessary have them changed by a workshop.

Before replacing a fuse, turn off the respective switch and the ignition.

A blown fuse can be recognised by its melted wire. Do not replace the fuse until the cause of the fault has been remedied.

Some functions are protected by several fuses.

Fuses may also be inserted without existence of a function.

Fuse extractor

A fuse extractor may be located in the fuse box in the engine compartment.

Place the fuse extractor on the various types of fuse from the top or side and withdraw fuse.

Engine Compartment Fuse Block

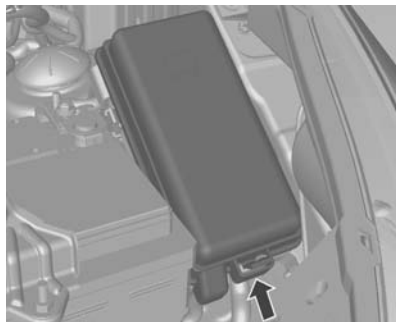

The fuse box is in the engine compartment.

Disengage the cover, lift it upwards and remove.

Note: Not all fuse box descriptions in this manual may apply to your vehicle.

When inspecting the fuse box, refer to the fuse box label.

10-26 Vehicle Care

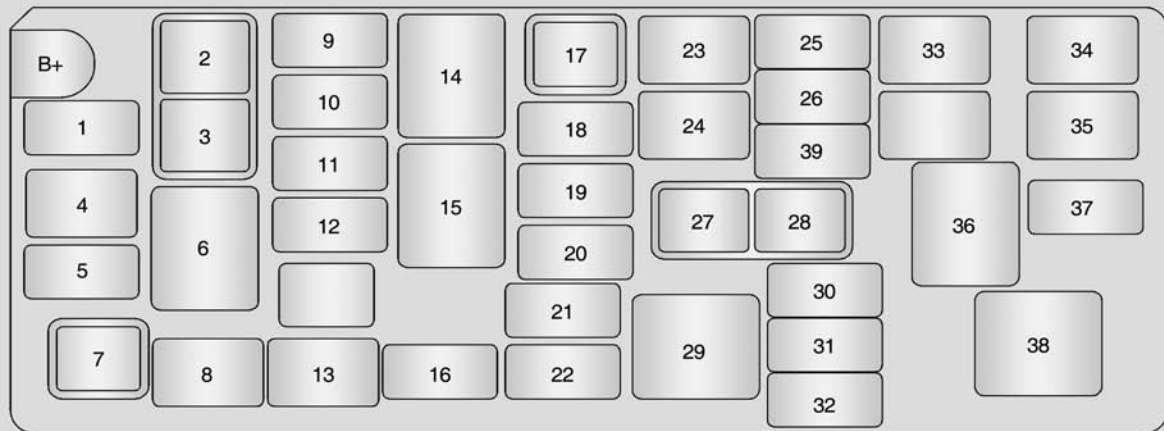

No.	Circuit
1	Fuel pump
2	Parking light relay
3	Fan low speed relay
4	Fan high speed
5	Air conditioning
6	Fan high speed relay
7	Air conditioning relay
8	ABS 2
9	Parking light LH
10	Parking light RH
11	Front fog light
12	Fan low speed
13	ABS 1
14	Front fog light relay
15	Fuel pump relay
16	Spare fuse
17	Headlight main beam relay
18	Headlight main beam

No.	Circuit
19	Headlight dipped beam LH
20	Headlight dipped beam RH
21	Spare fuse
22	Spare fuse
23	Ignition 2 / starter
24	Ignition 1 / accessory
25	Hazard lights
26	Horn
27	Headlight dipped beam relay
28	Horn relay
29	Engine main relay
30	Ignition
31	EMS 1
32	EMS 2
33	Instrument panel battery
34	-
35	Front window

No.	Circuit
36	Front window relay
37	Engine control module
38	-
39	Spare fuse

Instrument Panel Fuse Block

Type 1



Type 2

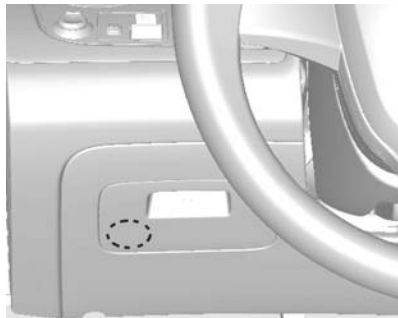

The interior fuse box is located on the underside of the driver's side instrument panel.

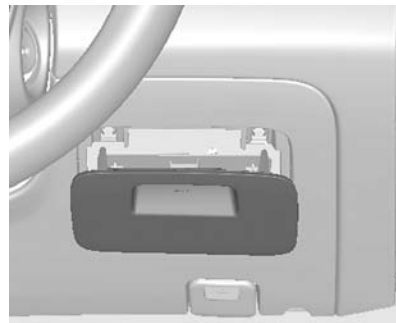

1. Open the fuse panel door by pulling out at the top.

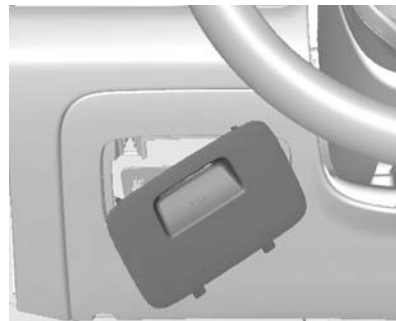

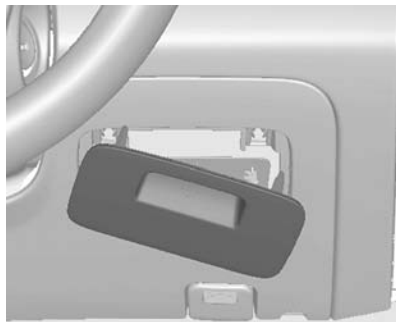

- Remove the fuse panel door diagonally.

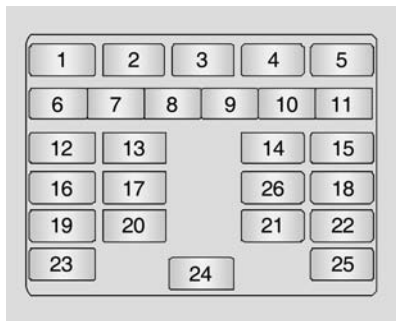

No.	Circuit
1	Rear wiper
2	Mirror/outside rear view mirror
3	Headlight
4	Electric OSRVM
5	Door lock
6	Front wiper
7	-
8	Reverse lights
9	Indicators
10	Rear demister
11	Rear fog lights
12	Instrument cluster
13	Blower motor control module
14	Airbag
15	Theft deterrent / data link connector

No.	Circuit
16	Transmission control module
17	Rear power windows
18	Radio / remote keyless entry / remote entry
19	Engine control module (ECM) / theft deterrent
20	Heat mat
21	Cigarette lighter
22	Brake light
23	Starter
24	Radio / clock / remote keyless entry
25	Airbag
26	Interior lights

Vehicle Tools

Tools

Vehicles with tyre repair kit

The tools and tyre repair kit are in a storage compartment below the floor cover in the load compartment.

Vehicles with spare wheel

The jack and the tools are in a storage compartment in the load compartment above the spare wheel.

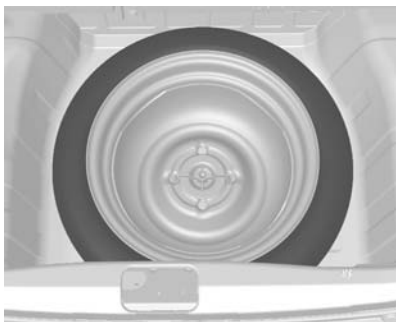

Compact spare wheel ⇨ *Compact Spare Tyre on page 10-46.*



Full-size spare wheel ⇨ *Full-Size Spare Tyre on page 10-47.*

Wheels and Tyres

Tyre condition, wheel condition
Drive over edges slowly and at right angles if possible. Driving over sharp edges can cause tyre and wheel damage. Do not trap tyres on the kerb when parking.

Regularly check the wheels for damage. Seek the assistance of a workshop in the event of damage or unusual wear.

Winter Tyres

Winter tyres improve driving safety at temperatures below 7 °C and should therefore be fitted on all wheels.

Tyre Designations

E.g. 215/60 R 16 95 H

215 = Tyre width, mm

60 = Cross-section ratio (tyre height to tyre width), %

R = Belt type: Radial

RF = Type: RunFlat

16 = Wheel diameter, inches

95 = Load index e.g. 95 is equivalent to 690 kg

H = Speed code letter

Speed code letter:

Q = up to 160 km/h (100 mph)

S = up to 180 km/h (112 mph)

T = up to 190 km/h (118 mph)

H = up to 210 km/h (130 mph)

V = up to 240 km/h (150 mph)

W = up to 270 km/h (168 mph)

Tyre Pressure

Check the pressure of cold tyres at least every 14 days and before any long journey. Do not forget the spare wheel.

Unscrew the valve cap.

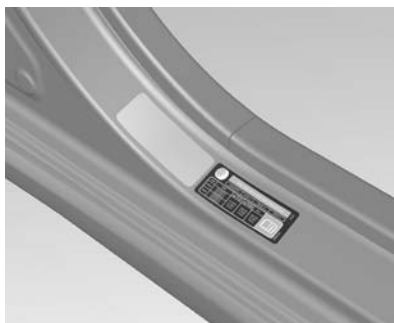
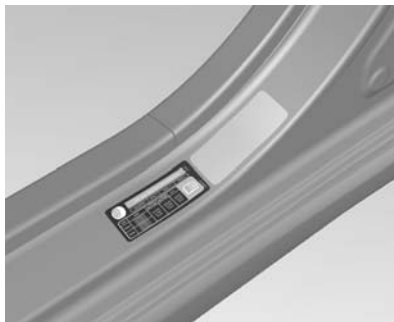

Tyre pressure ⇨ *Tyre Pressure on page 12-9* and on the label on the driver's door frame.

The tyre pressure data refers to cold tyres. It applies to summer and winter tyres.

Always inflate the spare tyre to the pressure specified for full load.

The ECO tyre pressure serves to achieve the smallest amount of fuel consumption possible.

Incorrect tyre pressures will impair safety, vehicle handling, comfort and fuel economy and will increase tyre wear.

Warning

If the pressure is too low, this can result in considerable tyre warmup and internal damage, leading to tread separation and even to tyre blow-out at high speeds.

Tyre Pressure Monitor System

The Tyre Pressure Monitor System (TPMS) uses radio and sensor technology to check tyre pressure levels. The TPMS sensors monitor the air pressure in your tyres and transmit tyre pressure readings to a receiver located in the vehicle.

Each tyre, including the spare, should be checked monthly when cold and inflated to the inflation pressure recommended the inflation pressure label.

As an added safety feature, your vehicle has been equipped with the low tyre pressure tell-tale (⚠).

The low tyre press tell-tale (⚠) illuminates when one or more of your tyres are significantly under-inflated.

When the low tyre press tell-tale illuminates, you should stop and check your tyres as soon as possible, and inflate them to the proper pressure.

Caution

Driving on a significantly under-inflated tyre causes the tyre to overheat and can lead to tyre failure. Under-inflation also reduces fuel efficiency and tyre tread life, and may affect the vehicle's handling and stopping ability.

Note: The TPMS is not a substitute for proper tyre maintenance, and it is the driver's responsibility to maintain correct tyre pressure, even if under-inflation has not reached the level to trigger illumination of the TPMS low tyre pressure tell-tale.

Your vehicle has also been equipped with the TPMS malfunction indicator (⚠) to indicate

when the system is not operating properly. The TPMS malfunction indicator is combined with the low tyre pressure telltale. When the system detects a malfunction, the TPMS malfunction indicator (⚠) will flash for approximately one minute and then remain continuously illuminated. This sequence will continue upon subsequent vehicle start-ups as long as the malfunction exists.

When the TPMS malfunction indicator is illuminated, the system may not be able to detect or signal low tyre pressure as intended.

Note: TPMS malfunctions may occur for a variety of reasons, including the installation of replacement or alternate tyres or wheels on the vehicle that prevent the TPMS from functioning properly.

Tyre Pressure Monitor Operation

This vehicle may have a Tyre Pressure Monitor System (TPMS).

The TPMS is designed to warn the driver when a low tyre pressure condition exists. TPMS sensors are mounted onto each tyre and wheel assembly, excluding the spare tyre and wheel assembly. The TPMS sensors monitor the air pressure in the tyres and transmit the tyre pressure readings to a receiver located in the vehicle.



When a low tyre pressure condition is detected, the TPMS illuminates the low tyre pressure tell-tale located on the instrument cluster.

If the low tyre pressure tell-tale is illuminated, stop as soon as possible and inflate the tyres to the recommended by the inflation pressure label.

The low tyre pressure tell-tale comes on at each ignition cycle until the tyres are inflated to the correct inflation pressure.

The low tyre pressure tell-tale may come on in cool weather when the vehicle is first started, and then turn off as the vehicle is driven. This could be an early indicator that the air pressure is getting low and must be inflated to the proper pressure.

Note: The low tyre pressure tell-tale may come on in cool weather when the vehicle is first started, and then turn off as the vehicle is driven. This could be an early indicator that the air pressure is getting low and must be inflated to the proper pressure.

Caution

Tyre sealant materials are not all the same. A non-approved tyre sealant could damage the TPMS sensors. TPMS sensor damage caused by using an incorrect tyre sealant is not covered by the vehicle warranty. Always use only the GM-approved tyre sealant available through your dealer or included in the vehicle.

TPMS Malfunction Indicator

The TPMS will not function properly if one or more of the TPMS sensors are missing or inoperable. When the system detects a malfunction, the TPMS malfunction indicator flashes for about one minute and then stays on for the remainder of the ignition cycle.

10-34 Vehicle Care

The TPMS malfunction indicator comes on at each ignition cycle until the problem is corrected. Some of the conditions that can cause these to come on are:

- The TPMS sensor matching process was not done or not completed successfully after rotating the tyres. The malfunction light should go off after successfully completing the sensor matching process. See "TPMS Sensor Matching Process" later in this section.
- One or more TPMS sensors are missing or damaged. The malfunction light should go off when the TPMS sensors are installed and the sensor matching process is performed successfully. See your dealer for service.
- Replacement tyres or wheels do not match the original equipment tyres or wheels. Tyres and

wheels other than those recommended could prevent the TPMS from functioning properly.

- Operating electronic devices or being near facilities using radio wave frequencies similar to the TPMS could cause the TPMS sensors to malfunction.

If the TPMS is not functioning properly, it cannot detect or signal a low tyre condition. See your dealer for service if the TPMS malfunction light comes on and stay on.

Tyre Load Menu

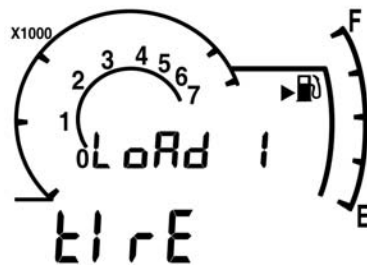

To adapt tyre pressure tell-tale to the vehicle loading conditions, press the MENU button until you see TPMS Setting Mode on the cluster.

Press the up or down arrow button until the Tyre Load screen is displayed.

Press the SET/CLR button. You can select the following menus.

Each menu can be selected by pressing the up or down arrow button.

- Load 1: Lo (Comfort tyre pressure mode)
- Load 2: Lo (Comfort tyre pressure mode)
- Load 3: Hi (GVW tyre pressure mode)

Press the SET/CLR button a few seconds to confirm.

Note: The tyre inflation pressure label is on the driver side door frame.

For the correct tyre pressure, refer to the recommended pressure on the tyre inflation pressure label

TPMS Sensor Matching Process

Each TPMS sensor has a unique identification code. The identification code needs to be matched to a new tyre/wheel position after rotating the tyres or replacing one or more of the TPMS sensors. The TPMS sensor matching process should also be performed after replacing a spare tyre with a road tyre containing the

TPMS sensor. The malfunction light should go off at the next ignition cycle. The sensors are matched to the tyre/ wheel positions, using a TPMS relearn tool, in the following order: left front tyre, right front tyre, left rear tyre and left rear tyre. See your dealer for service or to purchase a relearn tool.

There are two minutes to match each tyre/wheel position. If it takes longer, the matching process stops and must be restarted.

1. Apply the parking brake.
2. Turn the ignition to ON/RUN with the engine off.
3. Use the MENU button on the right side of instrument to select the menu in the Driver Information Centre(DIC)

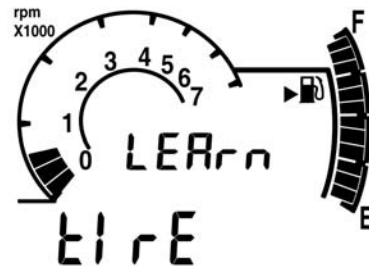

4. Press the MENU button until you see TPMS Setting Mode on the cluster.
 - TPMS Setting Mode consists of Learn Mode and Tyre Load Mode
5. If you are in Learn mode, press the Set/Clear button on cluster for more than 2 seconds
6. The cluster will display LF (Left Front). The TPMS global tell-tale will flash, and the chime sound will be heard, once in every 5 seconds. Use the relearn tool to activate the Left Front sensor.

10-36 Vehicle Care

7. When the LF sensor learn is completed, the cluster will display RF (Right Front). The TPMS global tell-tale will flash, and the chime sound will be heard, twice in every 5 seconds. Use the relearn tool to activate the Right Front sensor.
8. When the RF sensor learn is completed, the cluster will display RR (Right Rear). The TPMS global tell-tale will flash, and the chime sound will be heard, three times in every 5 seconds. Use the relearn tool to activate the Right Rear sensor.
9. When the RR sensor learn is completed, the cluster will display LR (Left Rear). The TPMS global tell-tale will flash, and the chime sound will be heard, four times in every 5 seconds. Use the relearn tool to activate the Left Rear sensor.
10. When LR learn is completed, the tell-tale will flash, and the chime sound will be heard, twice within two seconds. This will indicate that the learn procedure is completed.
11. Turn the ignition to LOCK/OFF.
12. Set all four tyres to the recommended air pressure level as indicated on the Tyre and Loading Information label. Use the Tyre Load Menu to select the correct load option in the TPMS.

Warning

Use of unsuitable tyres or wheels may lead to accidents and will invalidate the vehicle type approval.

Warning

Do not use different size and type of tyres and wheels than those originally installed on the vehicle. It can affect safety and performance of the vehicle. It could lead to handling failure or rollover and serious injury.

When replacing tyres, be sure to install all four tyres and wheels of the same size, type, tread, brand and load-carrying capacity. The use of any other tyre size or type may seriously affect ride, handling, ground clearance, stopping distance, body clearance and speedometer reliability.

Warning

Use of unsuitable tyres could lead to sudden pressure loss and cause accidents.

Tread Depth

Check tread depth at regular intervals.

Tyres should be replaced for safety reasons at a tread depth of 2-3 mm (4 mm for winter tyres).

For safety reasons it is recommended that the tread depth of the wheels on one axle should not vary by more than 2 mm.



The legally permissible minimum tread depth (1.6 mm) has been reached when the tread has worn

down as far as one of the tread wear indicators (TWI). Their position is indicated by markings on the sidewall.

If there is more wear at the front than the rear, swap round front wheels and rear wheels. Ensure that the direction of rotation of the wheels is the same as before.

Tyres age, even if they are not used. We recommend tyre replacement every 6 years.

Tyre Rotation

Tyres should be rotated every 12,000 km (7,500 miles) to achieve a more uniform wear of all tyres.

The first rotation is the most important.

Any time unusual wear is noticed, rotate the tyres as soon as possible and check the wheel alignment. Also check for damaged tyres or wheels.

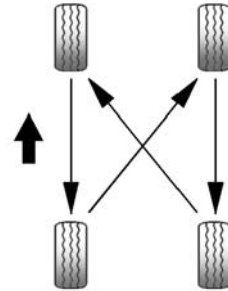

When rotating the tyres, always use the correct rotation pattern shown here. Do not include the spare tyre in the tyre rotation. Adjust the front and rear tyres to the recommended inflation pressure on the Tyre and Loading Information label after the tyres have been rotated.

Reset the Tyre Pressure Monitor System.

Check that all wheel nuts are properly tightened.

 **Warning**

Rust or dirt on a wheel, or on the parts to which it is fastened, can cause the wheel nuts to become loose with time. The wheel could come off and cause an accident. When changing a wheel, remove any rust or dirt from places where the wheel is attached to the vehicle. In an emergency, a cloth or a paper towel can be used; however, use a scraper or wire brush later to remove all rust or dirt.

Lightly coat the centre of the wheel hub with wheel bearing grease after a wheel change or tyre rotation to prevent corrosion or rust build-up. Do not get grease on the flat wheel mounting surface or on the wheel nuts or bolts.

Different Size Tyres and Wheels

If tyres of a different size than those fitted at the factory are used, it may be necessary to reprogram the speedometer as well as the nominal tyre pressure and make other vehicle modifications.

After converting to a different tyre size, have the label with tyre pressures replaced.

 **Warning**

Use of unsuitable tyres or wheels may lead to accidents and will invalidate the vehicle type approval.

 **Warning**

Do not use different size and type of tyres and wheels than those originally installed on the vehicle. It can affect safety and performance of the vehicle. It could lead to handling failure or rollover and serious injury. When replacing tyres, be sure to install all four tyres and wheels of the same size, type, tread, brand and load-carrying capacity. The use of any other tyre size or type may seriously affect ride, handling, ground clearance, stopping distance, body clearance and speedometer reliability.

Wheel Covers

Wheel covers and tyres that are factory approved for the respective vehicle and comply with all of the relevant wheel and tyre combination requirements must be used.

If the wheel covers and tyres used are not factory approved, the tyres must not have a rim protection ridge.

Wheel covers must not impair brake cooling.

Warning

Use of unsuitable tyres or wheel covers could lead to sudden pressure loss and thereby accidents.

Wheel Alignment and Tyre Balance

The tyres and wheels were aligned and balanced at the factory to provide the longest tyre life and best overall performance. Adjustments to wheel alignment and tyre balancing are not necessary on a regular basis.

Your vehicle's suspension and steering systems need some time to settle from the shipping process,

and adjust to the way you drive and the amount of passengers and cargo you carry with you. GM recommends that you drive your new vehicle at least 800 kilometres before evaluating your vehicle for steering pull. Some slight pull to the left or right, depending on the crown of the road and/or other road surface variations such as troughs or ruts, is normal. So, consider requesting an alignment check only if the vehicle is significantly pulling to one side or the other, or if you notice unusual tyre wear. If the vehicle is vibrating when driving on a smooth road, the tyres and wheels may need to be rebalanced.

See your Chevrolet authorised repairer for proper diagnosis.

Wheel Replacement

Mixing tyres could cause you to lose control while driving.

If you mix tyres of different sizes, brands, or types (radial and bias-belted tyres), the vehicle may

not handle properly, and you could have a crash. Using tyres of different sizes, brands, or types may also cause damage to your vehicle. Be sure to use the correct size, brand, and type of tyres on all wheels.

Some vehicles are equipped with a tyre repair kit instead of a spare wheel → *Tyre Repair Kit on page 10-43.*

Make the following preparations and observe the following information:

- Pull your vehicle over to a safe place away from traffic.
- Park the vehicle on a level, firm and non-skid surface. The front wheels must be in the straight-ahead position.
- Apply the parking brake and engage first gear or reverse gear.
- Turn off the engine and remove key.

10-40 Vehicle Care

- Turn on the hazard warning flashers.
- Use a wedge, block of wood, or rocks in front of and behind the tyre that is diagonal from the tyre you plan to change.
- All passengers must get out of the vehicle.
- Remove the spare wheel → *Compact Spare Tyre on page 10-46.*
- Never change more than one wheel at once.
- Use the jack only to change wheels in case of puncture, not for seasonal winter or summer tyre change.
- No people or animals may be in the vehicle when it is jacked-up.
- Never crawl under a jacked-up vehicle.
- Do not start the vehicle when it is raised on the jack.
- Clean wheel nuts and thread before mounting the wheel.

Warning

We designed the jack for use on your vehicle only.

Do not use jack provided with your vehicle on other vehicles.

Never exceed the jack's maximum permissible load.

Use of this jack on other vehicles may damage the other vehicles or your jack and lead to personal injury.



1. Disengage wheel nut caps with a screwdriver and remove.



2. Fold out the wheel wrench and install ensuring that it locates securely and loosen each wheel nut by half a turn.



3. Rotate the jack handle to raise the lift head slightly and place the jack vertically at the position marked with half circle.



4. Attach jack handle to the jack and attach wrench to the jack handle correctly.
Then raise the jack to join the lift head at the jacking position firmly.



5. Rotate the wrench checking the correct position of jack until wheel is clear of the ground.
6. Unscrew the wheel nuts.
7. Change the wheel.
8. Screw on the wheel nuts.
9. Lower vehicle.
10. Install the wheel wrench ensuring that it locates securely and tighten each nut in a crosswise sequence. Tightening torque is 120 Nm.

11. Align the valve hole in the wheel cover with the tyre valve before installing.

Install wheel nut caps.

12. Stow the replaced wheel and the vehicle tools. To prevent the rattling noise, turn screw head until the top and bottom of the jack are completely squeezed to the toolbox after returning the jack to its original position. At this time, make sure that jack has some clearance to any vehicle tool.

Tools ⇨ *Tools on page 10-30.*

13. Check the tyre pressure of the installed tyre and also the wheel nut torque as soon as possible.

Have the defective tyre renewed or repaired.

Warning

Rust or dirt on a wheel, or on the parts to which it is fastened, can cause the wheel nuts to become loose with time. The wheel could come off and cause an accident. When changing a wheel, remove any rust or dirt from places where the wheel is attached to the vehicle. In an emergency, a cloth or a paper towel can be used; however, use a scraper or wire brush later to remove all rust or dirt.

Lightly coat the centre of the wheel hub with wheel bearing grease during a wheel change to prevent corrosion or rust build-up. Do not get grease on the flat wheel mounting surface or on the wheel nuts or bolts.

Tyre Chains



Tyre chains are only permitted on the front wheels.

Always use fine mesh chains that add no more than 10 mm to the tyre tread and the inboard sides (including chain lock).

Warning

Damage may lead to tyre blowout.

Tyre Repair Kit

Minor damage to the tyre tread or sidewall can be repaired with the tyre repair kit.

Do not remove foreign bodies from the tyres.

Tyre damage exceeding 4 mm or that is at tyre's side wall near the rim cannot be repaired with the tyre repair kit.

Warning

Do not drive faster than 80 km/h (50 mph).

Do not use for a lengthy period.

Steering and handling may be affected.

If you have a flat tyre:

Apply the parking brake and engage first gear or reverse gear.

The tyre repair kit is in a compartment under the floor cover in the load compartment.

1. Take the tyre repair kit from the compartment.
2. Remove the compressor and the sealant bottle.

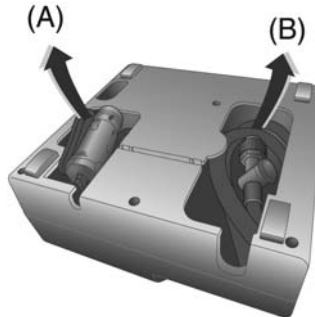

3. Remove the electrical connection cable and air hose from the stowage compartments on the underside of the compressor.

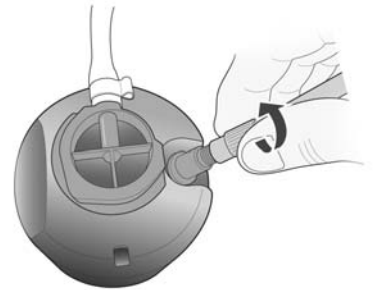

4. The switch on the compressor must be set to .
5. Screw the compressor air hose to the connection on the sealant bottle.
6. Connect the compressor plug to the accessory socket. To avoid discharging the battery, we recommend running the engine.
7. Fit the sealant bottle into the retainer on the compressor.

Set the compressor near the tyre in such a way that the sealant bottle is upright.

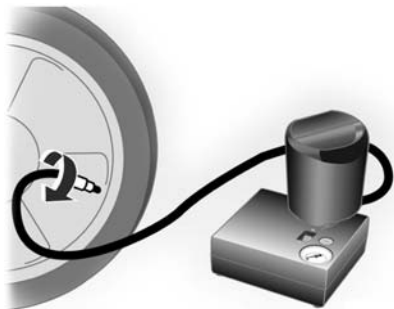

8. Unscrew valve cap from defective tyre.
9. Screw the filler hose to the tyre valve.

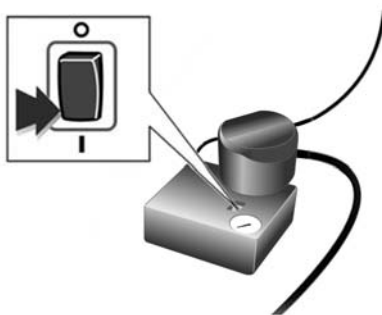

10. Set the rocker switch on the compressor to I. The tyre is filled with sealant.
11. The compressor pressure gauge briefly indicates up to 6 bar whilst the sealant bottle is emptying (approx. 30 seconds). Then the pressure starts to drop.
12. All of the sealant is pumped into the tyre. Then the tyre is inflated.

13. The prescribed tyre pressure (About 2.2 bar) should be obtained within 10 minutes. When the correct pressure is obtained, switch off the compressor.

If the prescribed tyre pressure is not obtained within 10 minutes, remove the tyre repair kit. Move the vehicle one tyre rotation. Reattach the tyre repair kit and continue the filling procedure for 10 minutes. If the prescribed tyre pressure is still not obtained, the tyre is too badly damaged. Seek the assistance of a workshop. Drain excess tyre pressure with the button over the pressure indicator.

Do not run the compressor longer than 10 minutes.

14. Detach the tyre repair kit. Push catch on bracket to remove sealant bottle from bracket. Screw tyre inflation hose to the free connection of sealant

- bottle. This prevents sealant from escaping. Stow tyre repair kit in load compartment.
- Remove any excess sealant using a cloth.
 - Take the label indicating maximum permitted speed (approx. 80 km/h (50 mph)) from the sealant bottle and affix in the driver's field of view.

- Continue driving immediately so that sealant is evenly distributed in the tyre. After driving approx. 10 km ((6 miles) but no more than 10 minutes), stop and check tyre pressure. Screw compressor air hose directly onto tyre valve and compressor when doing this.

If tyre pressure is more than 1.3 bar, set it to the correct value (approx. 2.2 bar). Repeat the procedure (no.17) until there is no more loss of pressure.

If the tyre pressure has fallen below 1.3 bar, the vehicle must not be used. Seek the assistance of a workshop.

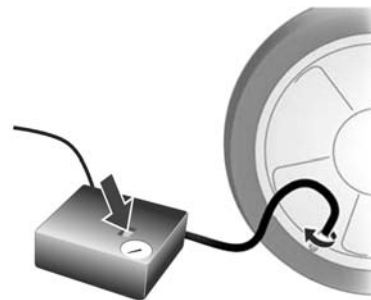

- Stow away tyre repair kit in load compartment.

Note: The driving comfort of the repaired tyre is severely affected, therefore have this tyre replaced.

If unusual noise is heard or the compressor becomes hot, turn compressor off for at least 30 minutes.

Note the expiry date of the kit. After this date its sealing capability is no longer guaranteed. Pay attention to storage information on sealant bottle.

Replace the used sealant bottle.
Dispose of the bottle as prescribed
by applicable laws.

The compressor and sealant can be
used from approx. -30 °C ~ 70 °C.

Compact Spare Tyre

Compact spare wheel

The spare wheel can be classified
as a temporary spare wheel
depending on the size compared to
the other mounted wheels and
country regulations.

The spare wheel has a steel rim.

Use of a spare wheel that is smaller
than the other wheels or together
with winter tyres could affect
driveability. Have the defective tyre
replaced as soon as possible.

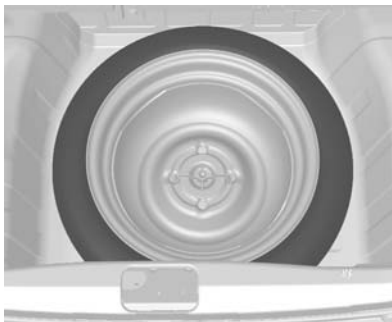

The spare wheel is located in the
load compartment beneath the floor
covering. It is secured in the recess
with a wing nut.

The spare wheel well is not
designed for all permitted tyre sizes.
If a wheel wider than the spare must
be stowed in the spare wheel well
after changing wheels, the floor
cover can be placed on the
projecting wheel.

Caution

This spare wheel/tyre assembly is
for temporary emergency
use only.

Replace with regular wheel/tyre
assembly as soon as possible.

Do not use tyre chains.

Do not install any tyre on this
wheel which is not identical to the
original.

Do not install on other vehicles.

Place alloy wheel face upward.

Place steel wheel face downward.

Temporary spare wheel

Use of the temporary spare wheel
could affect driveability. Have the
defective tyre renewed or repaired
as soon as possible.

Only mount one temporary spare wheel. Do not drive faster than 80 km/h (50 mph). Take bends slowly. Do not use for a long period of time.

Tyre chains ⇨ *Tyre Chains on page 10-42.*

Full-Size Spare Tyre

Full-size spare wheel

Use of a spare wheel that is same as the other wheels or together with winter tyres could affect driveability. Have the defective tyre replaced as soon as possible.



The spare wheel is located in the load compartment beneath the floor covering. It is secured in the recess with a wing nut.

Directional tyres

Fit directional tyres such that they roll in the direction of travel. The rolling direction is indicated by a symbol (e.g. an arrow) on the sidewall.

The following applies to tyres fitted opposing the rolling direction:

- Driveability may be affected. Have the defective tyre renewed or repaired as soon as possible.
- Do not drive faster than 80 km/h (50 mph).
- Drive particularly carefully on wet and snow-covered road surfaces.

Jump Starting

Do not start with quick charger.

A vehicle with a discharged battery can be started using jump leads and the battery of another vehicle.

Warning

Be extremely careful when starting with jump leads. Any deviation from the following instructions can lead to injuries or damage caused by battery explosion or damage to the electrical systems of both vehicles.

Warning

Avoid contact of the battery with eyes, skin, fabrics and painted surfaces. The fluid contains

(Continued)

Warning (Continued)

sulphuric acid which can cause injuries and damage in the event of direct contact.

- Never expose the battery to naked flames or sparks.
 - A discharged battery can already freeze at a temperature of 0 °C. Defrost the frozen battery before connecting jump leads.
 - Wear eye protection and protective clothing when handling a battery.
 - Use a booster battery with the same voltage (12 Volts). Its capacity (Ah) must not be much less than that of the discharged battery.
 - Use jump leads with insulated terminals and a cross section of at least 16 mm².
- Do not disconnect the discharged battery from the vehicle.
 - Switch off all unnecessary electrical consumers.
 - Do not lean over the battery during jump starting.
 - Do not allow the terminals of one lead to touch those of the other lead.
 - The vehicles must not come into contact with each other during the jump starting process.
 - Apply the parking brake, gearbox in neutral, automatic transmission in P.

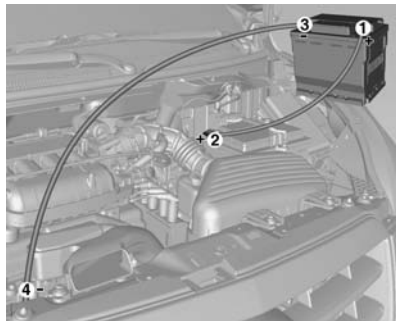

Lead connection order:

1. Connect the red lead to the positive terminal of the booster battery.
2. Connect the other end of the red lead to the positive terminal of the discharged battery.
3. Connect the black lead to the negative terminal of the booster battery.
4. Connect the other end of the black lead to a vehicle grounding point, such as the engine block or an engine mounting bolt.

Connect as far away from the discharged battery as possible, however at least 60 cm (2 ft).

Route the leads so that they cannot catch on rotating parts in the engine compartment.

To start the engine:

1. Start the engine of the vehicle providing the jump.
2. After 5 minutes, start the other engine. Start attempts should be made for no longer than 15 seconds at an interval of 1 minute.
3. Allow both engines to idle for approx. 3 minutes with the leads connected.
4. Switch on electrical consumers (e.g. headlights, heated rear window) of the vehicle receiving the jump start.
5. Reverse above sequence exactly when removing leads.

Towing the Vehicle

If you need to have your vehicle towed, please use our service network or professional towing company.

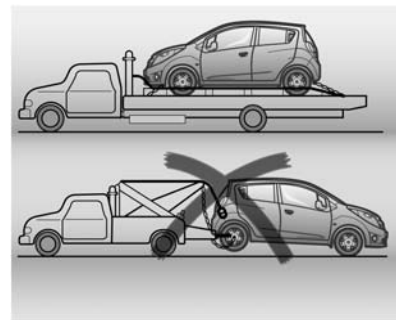

The best method is to have the vehicle transported using a recovery vehicle.

10-50 Vehicle Care

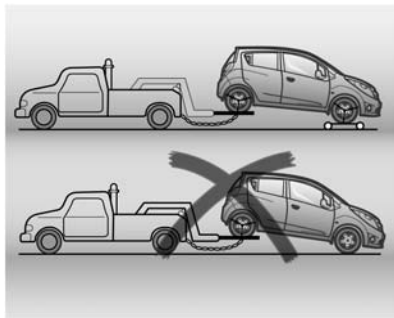
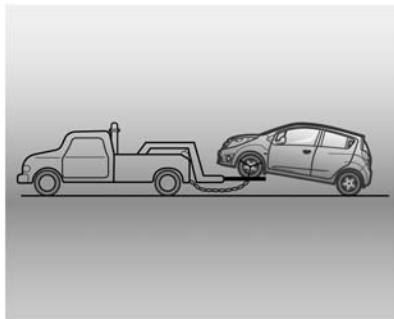

If towing by 2 wheels, lift the front driving wheels and tow with the front tyres locked.

Please observe the following procedures when towing a vehicle:

- No passenger should remain in the vehicle being towed.
- Release the parking brake of the towed vehicle and place the transmission gear in neutral.
- Switch on the emergency warning lights.
- Keep the speed limits.

If it is not possible to have your vehicle towed a recovery vehicle, proceed as follows:



<Type 1>

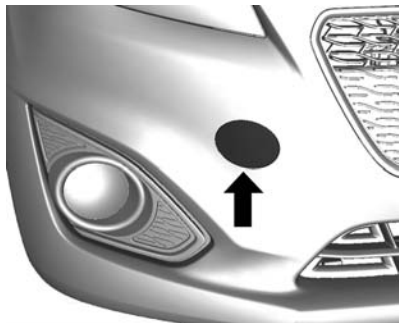

<Type 2>

Disengage cap at bottom and remove downwards.

The towing eye is stowed with the vehicle tools ⇨ *Tools on page 10-30.*



<Type 1>



<Type 2>

Screw in the towing eye as far as it will go until it stops in a horizontal position.

Attach a tow rope — or better still a tow rod — to the towing eye.

The towing eye must only be used for towing and not for recovering the vehicle.

Switch on ignition to release steering wheel lock and to permit operation of brake lights, horn and windscreen wiper.

Transmission in neutral.

⚠ Caution

Drive slowly. Do not drive jerkily. Excessive tractive force can damage the vehicle.

When the engine is not running, considerably more force is needed to brake and steer.

10-52 Vehicle Care

To prevent the entry of exhaust gases from the towing vehicle, switch on the air recirculation and close the windows.

Vehicle with automatic transmission: Do not tow the vehicle using tow eye. Towing with a tow rope could cause severe automatic transaxle damage. When towing vehicle with automatic transaxle, use flat bed or wheel lift equipment.

Vehicle with manual gearbox: The vehicle must be towed facing forward, not faster than 88 km/h (55 mph). In all other cases and when the transmission is defective, the front axle must be raised off the ground.

Seek the assistance of a workshop.

After towing, unscrew the towing eye.

Type 1: Insert cap on left side and close cap.

Type 2: Insert cap at the bottom and close cap. The best method is to have the vehicle transported using a recovery vehicle.

Towing Another Vehicle

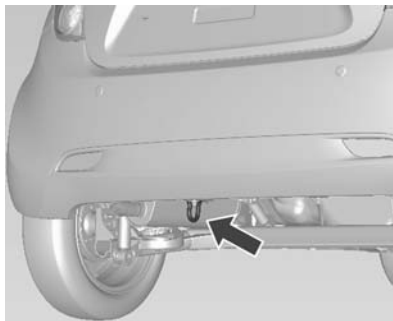

The rear towing eye is located under the rear bumper.

The towing eye must only be used for towing and not for recovering a vehicle.

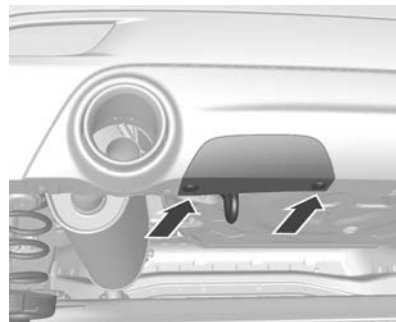

If your vehicle has a cover on the rear bumper in front of the rear towing eye, remove two clips from the cover. Disengage cover by pulling backward.

After towing, reinstall the cover firmly.

Caution

Drive slowly. Do not drive jerkily. Excessive tractive force can damage the vehicle.

Appearance Care

Exterior Care

Locks

The locks are lubricated at the factory using a high quality lock cylinder grease. Use de-icing agent only when absolutely necessary, as this has a degreasing effect and impairs lock function. After using de-icing agent, have the locks re-greased by a workshop.

Washing

The paintwork of your vehicle is exposed to environmental influences. Wash and wax your vehicle regularly. When using automatic vehicle washes, select a programme that includes waxing.

Bird droppings, dead insects, resin, pollen and the like should be cleaned off immediately, as they contain aggressive constituents which can cause paint damage.

If using a vehicle wash, comply with the vehicle wash manufacturer's instructions. The windscreen wipers and rear window wiper must be switched off. Lock the vehicle so that the fuel filler flap cannot be opened. Remove antenna and external accessories such as roof racks etc.

If you wash your vehicle by hand, make sure that the insides of the wheel housings are also thoroughly rinsed out.

Clean edges and folds on opened doors and the bonnet as well as the areas they cover.

Have the door hinges of all doors greased by a workshop.

Do not clean the engine compartment with a steam-jet or high-pressure jet cleaner.

Thoroughly rinse and leather-off the vehicle. Rinse leather frequently. Use separate leathers for painted

and glass surfaces: remnants of wax on the windows will impair vision.

Do not use hard objects to remove spots of tar. Use tar removal spray on painted surfaces.

Decal applied vehicle

Please do not wash the car for 72 hours from delivery to ensure adequate adhesion of decal.

When cleaning with high pressure water or a steam wand car wash, please make sure to keep a distance of at least 20 cm (8 inches) and not to focus on one point for more than 1 second. Otherwise, the decal could be damaged.

Exterior lights

Headlight and other light covers are made of plastic. Do not use any abrasive or caustic agents, do not use an ice scraper, and do not clean them when dry.

When removing insect debris, grease dirt or tar from the lights or lenses, only use lukewarm water, a soft cloth and a car washing soap.

Hard cleaning with a dry cloth can damage the light covers. Do not clean with intensive car washing fluid. Avoid using hazardous cleaners. It can cause the lens to crack by a chemical reaction.

Note: Refer to a car washing guide and only use mild detergents to avoid damage to the headlight lens. Never use cleaning fluids which contain any of the following:

- Acetone
- Benzene
- Toluene
- Xylene
- Thinners

Polishing and waxing

Wax the vehicle regularly (at the latest when water no longer beads). Otherwise, the paintwork will dry out.

Polishing is necessary only if the paint has become dull or if solid deposits have become attached to it.

Paintwork polish with silicone forms a protective film, making waxing unnecessary.

Plastic body parts must not be treated with wax or polishing agents.

Windows and windscreen wiper blades

Use a soft lint-free cloth or chamois leather together with window cleaner and insect remover.

When cleaning the rear window, make sure the heating element inside is not damaged.

For mechanical removal of ice, use a sharp-edged ice scraper. Press the scraper firmly against the glass so that no dirt can get under it and scratch the glass.

Clean smearing wiper blades with a soft cloth and window cleaner.

Wheels and tyres

Do not use high-pressure jet cleaners.

Clean rims with a pH-neutral wheel cleaner.

Rims are painted and can be treated with the same agents as the body.

Paintwork damage

Rectify minor paintwork damage with a touch-up pen before rust forms. Have more extensive damage or rust areas repaired by a workshop.

Special package and body kit

- Be careful when towing to prevent damage by the tow rope. Remove cover in bumper before towing.
- Reduced ground clearance. Drive slowly over ramps, bumps or kerbs.
- Use support when lifting the vehicle.
- To prevent body damage and breakage, it is recommended to completely lift the vehicle onto a recovery vehicle when transporting the vehicle.

Underbody

Corrosive materials used for ice and snow removal or dust control can collect on the underbody of your vehicle. Failure to remove these materials can accelerate corrosion and rust.

Periodically use plain water to flush these materials from the underbody of your vehicle.

Take care to clean any areas in which mud and other debris can collect. Loosen any sediment packed in closed areas before flushing with water.

Interior Care

Interior and upholstery

Only clean the vehicle interior, including the instrument panel fascia and panelling, with a dry cloth or interior cleaner.

The instrument panel should only be cleaned using a soft damp cloth.

Clean fabric upholstery with a vacuum cleaner and brush. Remove stains with an upholstery cleaner.

Clothing fabrics may not be colour-fast. This could cause visible discolourations, especially on light coloured upholstery. Removable stains and discolourations should be cleaned as soon as possible.

Clean seat belts with lukewarm water or interior cleaner.

Caution

Close Velcro fasteners as open Velcro fasteners on clothing could damage seat upholstery.

Plastic and rubber parts

Plastic and rubber parts can be cleaned with the same cleaner as used to clean the body. Use interior cleaner if necessary. Do not use any other agent. Avoid solvents and petrol in particular. Do not use high-pressure jet cleaners.

Service and Maintenance

General Information

Service Information 11-1

Maintenance Schedule

Maintenance Schedule 11-2

Additional Maintenance and Care

Additional Maintenance and Care 11-7

Recommended Fluids, Lubricants, and Parts

Recommended Fluids and Lubricants 11-7

General Information

Service Information

In order to ensure economical and safe vehicle operation and to maintain the value of your vehicle, it is of vital importance that all maintenance work is carried out at the proper intervals as specified.

Confirmations

Confirmation of service is recorded in the Service Guide.

The date and mileage is completed with the stamp and signature of the servicing workshop.

Make sure that the Service Guide is completed correctly as continuous proof of service is essential if any warranty or goodwill claims are to be met, and is also a benefit when selling the vehicle.

11-2 Service and Maintenance

Maintenance Schedule

Service schedules

Maintenance Interval
Every 1 year / 15,000 km (10,000 miles) (whichever occurs first)

Maintenance I: Use Maintenance I for the first service or if Maintenance II was performed previously.

Maintenance II: Use Maintenance II if the previous service performed was Maintenance I.

No	Service operation	Maintenance I	Maintenance II
1	Replace engine oil and filter. (1)	R	R
2	Inspect for any leaks or damage. (2)	I	I
3	Inspect engine air filter. (3)	I	I
4	Inspect tyres for inflation pressures and wear.	I	I
5	Inspect brake system. (4)	I	I
6	Inspect engine coolant and windscreen washer fluid levels and add fluid as needed.	I	I

No	Service operation	Maintenance I	Maintenance II
7	Inspect suspension and steering components. (5)	I	I
8	Inspect wiper blades. (6)	I	I
9	Inspect drive belts.	I	I
10	Perform any required additional services - see applicable section.	I	I
11	Check for field actions.	I	I
12	Replace brake fluid. (7)	-	R
13	Inspect engine cooling system. (8)	-	I
14	Inspect restraint system components. (9)	-	I
15	Inspect powertrain and driveline components.	-	I
16	Lubricate body components. (10)	-	I

1 : If driving under severe conditions: short distance driving, extensive idling or driving in dusty condition, engine oil and the filter may require replacement more often.

2 : Fluid loss in any vehicle system could indicate a problem. The system should be inspected and repaired and the fluid level checked. Add fluid if needed.

3 : If driving regularly in dusty conditions, inspect the filter more frequently. The filter may require replacement more often.

4 : Visually inspect brake lines and hoses for binding, leaks, cracks, chafing, etc. Inspect disc brake pads for wear and discs for surface

11-4 Service and Maintenance

condition. Inspect drum brake linings/shoes for wear or cracks. Inspect other brake parts, including drums, wheel cylinders, callipers, handbrake, etc.

5 : Visually inspect front and rear suspension and steering system for damage, loose or missing parts or signs of wear. Inspect power steering components for binding, cracks, chafing, etc.

6 : Inspect wiper blades for wear, cracking, or contamination. Clean the windscreen and wiper blades, if contaminated. Replace wiper blades that are worn or damaged.

7 : If driving under severe conditions: driving in hilly or mountainous terrain, or towing a trailer frequently, brake fluid may require replacement more often.

8 : Visually inspect hoses and have them replaced if they are cracked, swollen, or deteriorated. Inspect all pipes, fittings, and clamps; replace with genuine parts if needed. To help ensure correct operation, a

pressure test of the cooling system and pressure cap and cleaning the outside of the radiator and air conditioning condenser is recommended.

9 : Make sure the safety belt reminder light and safety belt assemblies are working correctly. Look for any other loose or damaged safety belt system parts. If you see anything that might keep a safety belt system from doing its job, have it repaired. Ensure any torn or frayed safety belts are replaced.

10 : Lubricate all key lock cylinders, door hinges and latches, bonnet hinges and latches, and boot lid hinges and latches. More frequent lubrication may be required when exposed to a corrosive environment. Applying silicone grease on weatherstrips with a clean cloth will make them last longer, seal better, and not stick or squeak.

I: Inspect these items and their related parts. If necessary, correct, clean, replenish, adjust or replace.

R: Replace or change.

Service operation	Interval
Replace pollen filter. (3)	Every 15,000 km (10,000 miles) / 1 year
Replace air filter.	Every 60,000 km (40,000 miles) / 4 year
Replace spark plugs.	Every 30,000 km (20,000 miles) / 2 year
Replace ignition cable (for vehicles without Electronic Stability Control).	Every 45,000 km (30,000 miles) / 3 year
Replace engine coolant.	Every 240,000 km (160,000 miles) / 5 year
Replace manual gearbox oil.	Every 150,000 km (100,000 miles) / 10 years
Replace automatic transmission oil.	Inspect oil every 15,000 km (10,000 miles) / 1 year. Replace every 75,000 km (50,000 miles) for severe conditions.
Replace auxiliary belt.	(11)
Replace timing chain.	Every 240,000 km (160,000 miles) / 10 years
Inspect valve clearance, adjust if required.	Every 150,000 km (100,000 miles) / 10 years
Inspect clutch & brake pedal free play	Every 15,000 km (10,000 miles) / 1 year

3 : If driving regularly in dusty conditions, inspect the filter more frequently. The filter may require replacement more often.

11 : If the belt has been replaced, it must be inspected and tension must be adjusted within 6 months / 5,000 km (3,000 miles).

11-6 Service and Maintenance

General maintenance items

Item	Service operation
All	If driving under severe conditions: short distance driving, extensive idling or driving in dusty condition, engine oil and the filter may require replacement more often.
Automatic transmission	Change automatic transmission fluid and filter if the vehicle is mainly driven under one or more of these conditions: In heavy city traffic where the outside temperature regularly reaches 32 °C or higher. In hilly or mountainous terrain. When doing frequent trailer towing. Uses such as found in taxi, police, or delivery service.
Belts	Visually inspect belt for fraying, excessive cracks, or obvious damage. Replace belt if necessary.
Tyre condition & inflation pressure	Tyre condition should be inspected before driving and tyre pressure should be checked each time you fill your fuel tank or at least once a month using a tyre pressure gauge.
Wheel alignment	If necessary, rotate and balance wheels.

Additional Maintenance and Care

Extreme operating conditions

Extreme operating conditions are given when at least one of the following occurs frequently:

- Repeated short-distance driving less than 10 km (5 miles).
- Extensive idling and/or slow-speed driving in stop-and-go traffic.
- Driving on dusty roads.
- Driving on hilly or mountainous terrain.
- Towing a trailer.
- Driving in heavy city traffic where the outside temperatures regularly reach 32 °C or higher.
- Driving as a taxi, police or delivery vehicle.
- Frequent driving when outside temperature remains below freezing.

Police vehicles, taxis and driving school vehicles are also classified as operating under extreme conditions.

Under extreme operating conditions, it may be necessary to have certain scheduled service work done more frequently than the scheduled intervals.

Seek technical advice on the servicing requirements dependent on the specific operating conditions.

Recommended Fluids, Lubricants, and Parts

Recommended Fluids and Lubricants

Recommended fluids and lubricants

Only use products that have been tested and approved. Damage resulting from the use of non-approved materials will not be covered by the warranty.



Operating materials are hazardous and could be poisonous. Handle with care. Pay attention to information given on the containers.

11-8 Service and Maintenance

Engine oil

Use only engine oil that is approved to the dexos™ specification or an equivalent engine oil of the appropriate viscosity grade.

If you are unsure whether your oil is approved to the dexos™ specification, ask your service provider.

Use of substitute engine oils if dexos is unavailable: In the event that dexos approved engine oil is not available at an oil change or for maintaining proper oil level, you may use substitute engine oil of the qualities mentioned below. Use of oils that do not meet the dexos specification, however, may result in reduced performance and engine damage under certain circumstances.

Engine oil is identified by its quality and its viscosity. Quality is more important than viscosity when selecting which engine oil to use.

Selecting the right engine oil

Selecting the right engine oil depends on both the proper oil specification and viscosity grade.

Engine oil quality

- dexos1, dexos2
- API SM, ACEA-A3/B3: Optional for Gen1 engine (not used for Gen2 engine)

Specification

Use and ask for licensed engine oils with the dexos™ approved certification mark. Engine oils meeting the requirements for the vehicle should have the dexos™ approved certification mark. This certification mark indicates that the oil has been approved to the dexos™ specification.

Your vehicle's engine was filled at the factory with dexos™ approved engine oil.

Use only engine oil that is approved to the dexos™ specification or an equivalent engine oil of the

appropriate viscosity grade. Use of oils that do not meet the dexos specification, however, may result in reduced performance and engine damage under certain circumstances.

If you are unsure whether your oil is approved to the dexos™ specification, ask your service provider.

If you don't know vehicle engine type, ask your authorised repairer.

Engine oil viscosity

The SAE viscosity grade gives information of the thickness of the oil.

Multigrade oil is indicated by two figures:

The first figure, followed by a W, indicates low temperature viscosity and the second figure the high temperature viscosity.

The SAE viscosity rating defines the ability of an oil to flow. When cold, oil is more viscous than when hot.

Engine oil viscosity grade for 1.0D, 1.2D Gen1

SAE 5W-30 is the best viscosity grade for your vehicle. Do not use other viscosity grade oils such as SAE 20W-50. Cold temperature operation for 1.0D, 1.2D Gen1

- Down to -25 °C and below: 0W-30, 0W-40
- Down to -25 °C: 5W-30, 5W-40
- Down to -20 °C: 10W-30, 10W-40

Engine oil viscosity grade for 1.2D Gen2

SAE 5W-20 is the best viscosity grade for your vehicle. Do not use other viscosity grade oils such as SAE 10W-30, 10W-40 or 20W-50.

Cold temperature operation for 1.2D Gen2

If operating your vehicle in an area of extreme cold, where the temperature falls below -25°C, a viscosity grade SAE 0W-xx should be used. An oil of this viscosity

grade will provide easier cold starting for the engine at extremely low temperatures.

When selecting an oil of the appropriate viscosity grade be sure to always select an oil that meets the dexos™ specification.

- Down to -25°C and below: 0W-20, 0W-30.
- Down to -25°C: 5W-20, 5W-30.

Engine oil additives/engine oil flushes

Do not add anything to the oil. The recommended oils with the dexos specification and displaying the dexos certification mark are all that is needed for good performance and engine protection.

Engine oil system flushes are not recommended and could cause engine damage not covered by the vehicle warranty.

Topping up engine oil

Engine oils of different manufacturers and brands can be mixed as long as they comply with the required engine oil (specification and viscosity).

If engine oil of the required quality is not available, a maximum of 1 Litre of API SM/SN, ACEA A3/B4, ACEA A3/B3 or ACEA C3 quality may be used (only once between each oil change).

The viscosity should be of the correct rating.

Use of engine oil with only ACEA A1/B1 or only ACEA A5/B5 quality is prohibited, as it can cause long term engine damage under certain operating conditions.

Coolant and antifreeze

Use only organic acid type-long life coolant (LLC) antifreeze.

In countries with moderate climate the coolant provides freeze protection down to approx. -35 °C.

11-10 Service and Maintenance

In countries with cold climate the coolant provides freeze protection down to approx. -50 °C. This concentration should be maintained all year round.

Maintain a sufficient concentration of anti-freeze.

Coolant additives intended to give additional corrosion protection or seal against minor leaks can cause function problems. Liability for consequences resulting from the use of coolant additives will be rejected.

Brake fluid

Only use our authorised brake fluid for this vehicle (DOT 4).

Over time, brake fluid absorbs moisture which will reduce braking effectiveness. The brake fluid should therefore be replaced at the specified interval.

Brake fluid should be stored in a sealed container to avoid water absorption.

Ensure brake fluid does not become contaminated.

Caution

Using low quality brake fluid may cause corrosion to internal components of the brake system, which may result in decreased brake system performance, which is a safety concern. Always use high quality brake fluid approved for your vehicle model. We recommend GM genuine brake fluid.

Power steering fluid

Only use Dexron VI fluid.

Manual gearbox fluid

Only use XGP SAE75W85W fluid.

Automatic transmission fluid

Only use ESSO JWS3317 fluid.

Technical Data

Vehicle Identification

Vehicle Identification	
Number (VIN)	12-1
Identification Plate	12-1

Vehicle Data

Engine Data	12-3
Performance	12-4
Vehicle Weight	12-6
Vehicle Dimensions	12-7
Capacities and	
Specifications	12-8
Tyre Pressure	12-9

Vehicle Identification

Vehicle Identification Number (VIN)

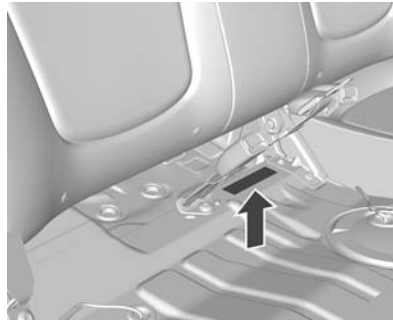

The vehicle identification number is located under the rear seat cushion.

Identification Plate

Type 1

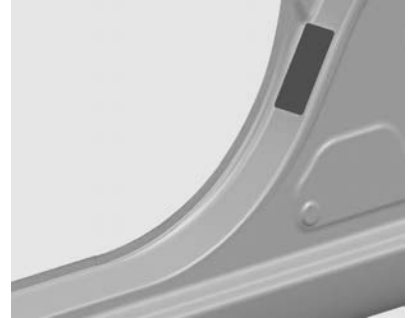

The label is attached near the driver's door latch.

12-2 Technical Data

Type 2

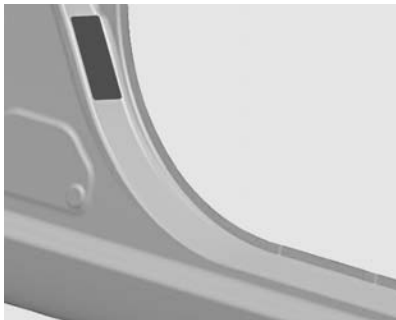

The label is attached near the front passenger's door latch.

Vehicle Data

Engine Data

Sales designation	1.0 Petrol	1.2 Petrol
Engine	1.0D	1.2D
Engine identifier code	LMT	LMU
Number of cylinders	4	4
Piston displacement [cm ³]	995	1,206
Engine power [kW] at rpm	50 6,400	60 6,400
Torque [Nm] at rpm	93 4,800	111 4,800
Fuel type	Petrol	Petrol
Octane rating RON		
recommended possible	95 Over 95	95 Over 95

12-4 Technical Data

Russia & Uzbekistan

Sales designation	1.0 Petrol	1.2 Petrol
Engine	1.0D	1.2D
Engine identifier code	B10D1	B12D2
Number of cylinders	4	4
Piston displacement [cm ³]	995	1,249
Engine power [kW] at rpm	50 6,400	62 6,200
Torque [Nm] at rpm	89 4,800	112 4,600
Fuel type	Petrol	Petrol
Octane rating RON		
recommended possible	91 Over 91	91 Over 91

Performance

Engine	1.0D	1.2D
Top speed (1) [mph]		
Manual gearbox	96	102

Engine	1.0D	1.2D
(1) The maximum speed indicated is achievable at kerb weight (without driver) plus 200 kg payload. Optional equipment could reduce the specified maximum speed of the vehicle.		

Engine	1.0D	1.2D
Top speed (2) [mph]		
Manual gearbox	154	164
(2) The maximum speed indicated is achievable at kerb weight (without driver) plus 200 kg payload. Optional equipment could reduce the specified maximum speed of the vehicle.		

Russia & Uzbekistan

Engine	1.0D	1.2D
Top speed (2) [mph]		
Manual gearbox	-	164
Automatic transmission	148	-
(2) The maximum speed indicated is achievable at kerb weight (without driver) plus 200 kg payload. Optional equipment could reduce the specified maximum speed of the vehicle.		

12-6 Technical Data

Vehicle Weight

Minimum kerb weight, with driver (75kg)

	Engine	Manual gearbox without power steering	Manual gearbox with power steering
[kg]	1.0D	932	939
	1.2D	932	939

Russia & Uzbekistan

	Engine	Manual gearbox	Automatic transmission
[kg]	1.0D	-	995
	1.2D	980	-

Maximum kerb weight, with driver (75kg)

	Engine	Manual gearbox without power steering	Manual gearbox with power steering
[kg]	1.0D	1047	1065
	1.2D	1047	1065

Russia & Uzbekistan

	Engine	Manual gearbox	Automatic transmission
[kg]	1.0D	-	1080
	1.2D	1065	-

Gross vehicle weight

	Engine	Manual gearbox without power steering	Manual gearbox with power steering
[kg]	1.0D	1347	1367
	1.2D	1347	1065

Russia & Uzbekistan

	Engine	Manual gearbox	Automatic transmission
[kg]	1.0D	-	1385
	1.2D	1367	-

Vehicle Dimensions

Length [mm]	3640
Width without exterior mirrors [mm]	1597

12-8 Technical Data

Width with two exterior mirrors [mm]	1910
Height (without aerial) [mm] without roof rack	1522
Height (without aerial) [mm] with roof rack	1551
Length of load compartment floor [mm]	548
Load compartment width [mm]	987
Load compartment height [mm]	435
Wheelbase [mm]	2375
Turning circle diameter [m]	9.9

Capacities and Specifications

Engine oil

Engine	1.0 DOHC	1.2 DOHC
including Filter [l]	3.75	3.75
between MIN and MAX [l]	2.5/3.5	2.5/3.5

Engine oil

Petrol, nominal capacity [l]	35
------------------------------	----

Tyre Pressure

Engine	Tyres	Comfort with up to 3 people		ECO with up to 3 people		With full load	
		front	rear	front	rear	front	rear
		[kPa/ bar] ([psi])	[kPa/ bar] ([psi])	[kPa/ bar] ([psi])	[kPa/ bar] ([psi])	[kPa/ bar] ([psi])	[kPa/ bar] ([psi])
1.0D, 1.2D	155/80 R13, 155/70 R14, 165/65 R14	220/2.2 (32)	220/2.2 (32)	240/2.4 (35)	240/2.4 (35)	235/ 2.35 (34)	235/ 2.35 (34)
All	Compact spare tyre	420/4.2 (60)	420/4.2 (60)	-	-	420/4.2 (60)	420/4.2 (60)

Tyre specifications in the owner's manual may be changed without notice, refer to the tyre label in your vehicle.

Customer Information

Customer Information

Declaration of Conformity 13-1

Vehicle Data Recording and Privacy

Event Data Recorders 13-2

Radio Frequency

Identification (RFID) 13-2

Customer Information

Declaration of Conformity

Transmission system

This vehicle has systems that transmit and/or receive radio waves subject to Directive 1999/5/EC.

These systems are in compliance with the essential requirements and other relevant provisions of Directive 1999/5/EC. Copies of the original Declarations of Conformity can be obtained on our website.

Jack

Translation of the original declaration of conformity

Declaration of conformity according to EC Directive 2006/42/EC

We declare that the product:

Product designation: Jack

Type/GM part number: 13503237

is in compliance with the provisions of Directive 2006/42/EC.

Applied technical standards:

GMN9737 = Jacking

GM 14337 = Standard Equipment
Jack Hardware Tests

GMN5127 = Vehicle Integrity
Hoisting and Service Station
Jacking

GMW15005 = Standard Equipment
Jack and Spare Tyre, Vehicle Test

ISO TS 16949 = Quality
management systems

The signatory is authorised to
compile the technical
documentation.

Rüsselsheim, 31st January 2014
signed by Hans-Peter Metzger

Engineering Group Manager
Chassis & Structure

Adam Opel AG

D-65423 Rüsselsheim

Vehicle Data Recording and Privacy

Event Data Recorders

Data storage modules in the vehicle

A large number of electronic components of your vehicle contain data storage modules temporarily or permanently storing technical data about the condition of the vehicle, events and errors. In general, this technical information documents the condition of parts, modules, systems or the environment:

- Operating conditions of system components (e.g. filling levels)
- Status messages of the vehicle and its single components (e.g. number of wheel revolutions / rotational speed, deceleration, lateral acceleration)

- Dysfunctions and defects in important system components
- Vehicle reactions in particular driving situations (e.g. inflation of an airbag, activation of the stability regulation system)
- Environmental conditions (e.g. temperature)

This data is exclusively technical and helps identify and correct errors as well as optimise vehicle functions.

Motion profiles indicating travelled routes cannot be created with these data.

If services are used (e.g. repair works, service processes, warranty cases, quality assurance), employees of the service network (manufacturer included) are able to read out this technical information from the event and error data storage modules applying special diagnostic devices. If required, you will receive further information at these workshops. After an error has

been corrected, the data is deleted from the error storage module or constantly overwritten.

When using the vehicle, situations may occur in which these technical data related to other information (accident report, damages on the vehicle, witness statements etc.) may be associated with a specific person - possibly, with the assistance of an expert.

Additional functions contractually agreed upon with the client (e.g. vehicle location in emergency cases) allow the transmission of particular vehicle data from the vehicle.

Radio Frequency Identification (RFID)

RFID technology is used in some vehicles for functions such as tyre pressure monitoring and ignition system security. It is also used in connection with conveniences such as radio remote controls for door locking/unlocking and starting, and

in-vehicle transmitters for garage door openers. RFID technology in Chevrolet vehicles does not use or record personal information or link with any other Chevrolet system containing personal information.

A

Accessories and Modifications 10-2

Additional Maintenance and Care 11-7

Adjustable Air Vents 8-9

Adjustments
Seat, Initial Drive 3-3

Air Cleaner/Filter, Engine 10-12

Air Conditioning 8-5

Air Conditioning Regular Operation 8-12

Air Filter, Passenger Compartment 8-11

Air Intake 8-10

Airbags
Curtain 3-15
Front 3-12
Light On-Off 5-16
On-Off Light 5-16
On-Off Switch 3-16
Safety Belt Tensioner Light 5-16
Side 3-13
System Check 3-11

Alarm System
Anti-theft 2-7

AM-FM Radio 7-11

Anti-theft
Alarm System 2-7

Antilock Brake System (ABS) 9-11
Warning Light 5-17

Appearance Care
Exterior 10-53
Interior 10-55

Ashtrays 5-9

Audio Players 7-23
CD 7-23

Audio System
Fixed Mast Aerial 7-22

Automatic
Transmission 9-4
Transmission Fluid 10-10

Automatic Transmission
Fault 9-8
Interruption of Power
Supply 9-8
Selector Lever 9-5

Auxiliary
Devices 7-32

B

Battery 10-17
Jump Starting 10-48
Power Protection 6-5

Blade Replacement, Wiper ... 10-18

Bluetooth
Overview 7-44

Bonnet 10-3

Brake
System Warning Light 5-17

Brakes 9-10
Antilock 9-11
Assist 9-12
Fluid 10-15
Parking 9-12

Bulb Replacement
Centre High-Mounted
Brake lamp (CHMBL) 10-23
Headlamps 10-19
Interior Lamps 10-23
Number Plate Lamps 10-23
Side Indicator Lamps 10-22
Taillights 10-21

C

Capacities and Specifications	12-8
Carbon Monoxide Engine Exhaust	9-4
Fuel Consumption CO2 Emissions	9-18
Catalytic Converter	9-4
Cautions, Danger, and Warnings	iii
CD Player	7-23
Central Locking System	2-4
Centre High-Mounted Brake lamp (CHMBL)	10-23
Chains, Tyre	10-42
Charging System Light	5-17
Check Engine Light	5-17
Child Restraint Installation Locations	3-19
Child Restraint Systems Top Tether	3-24

Child Restraints Installation Locations	3-19
ISOFIX	3-21
Systems	3-17
Cigarette Lighter	5-7
Cleaning Exterior Care	10-53
Interior Care	10-55
Climate Control Systems Heating and Ventilation	8-1
Clock	5-6
Compact Spare Tyre	10-46
Compartment Load	4-4
Compartments Storage	4-1
Computer, Trip	5-20
Conformity Declaration of	13-1
Control Indicators	5-12
Control of a Vehicle	9-1
Convenience Net	4-6
Convex Mirrors	2-10

Coolant Engine	10-12
Engine Temperature Warning Light	5-18
Covers Wheel	10-38
Cupholders	4-3
Curtain Airbag System	3-15

D

Danger, Warnings, and Cautions	iii
Data Recorders, Event	13-2
Daytime Running Lamps (DRL)	6-3
Declaration of Conformity	13-1
Devices Auxiliary	7-32
Dimensions Vehicle	12-7
Displays Transmission	5-15
Door Ajar Light	5-20
Central Locking System	2-4

E

Electrical System
 Engine Compartment
 Fuse Block 10-25
 Fuses 10-24
 Instrument Panel Fuse
 Block 10-27
 Electronic Stability Control 9-13
 Electronic Stability Control
 (ESC) Off Light 5-18
 Electronic Stability Control
 Indicator Light 5-18
 Emissions - CO2
 Fuel Consumption 9-18
 End-of-Life Vehicle
 Recovery 10-3
 Engine
 Air Cleaner/Filter 10-12
 Check and Service Engine
 Soon Light 5-17
 Compartment Overview 10-6
 Coolant 10-12
 Coolant Temperature
 Warning Light 5-18

Engine (cont'd)
 Exhaust 9-4
 Pressure Light 5-19
 Starting 9-3
 Engine Data 12-3
 Engines
 Petrol Fuel 9-16
 Event Data Recorders 13-2
 Exterior Lamp Controls 6-1

F

Fault, Automatic
 Transmission 9-8
 Filter,
 Engine Air Cleaner 10-12
 Fixed Air Vents 8-10
 Flash-to-Pass 6-2
 Fluid
 Automatic Transmission 10-10
 Brakes 10-15
 Power Steering 10-14
 Washer 10-15
 Fog Lamp Light, Rear 5-20
 Fog Lamps
 Front 6-4
 Rear 6-4

Folding Mirrors 2-11
 Front Airbag System 3-12
 Front Fog Lamp
 Light 5-19
 Front Seat Position Seats
 Adjustment 3-3
 Front Seats
 Adjustment 3-4
 Heated 3-6
 Fuel
 Consumption - CO2 -
 Emissions 9-18
 Filling the Tank 9-16
 Gauge 5-12
 Low Fuel Warning Light 5-19
 Petrol Engines 9-16
 Full-Size Spare Tyre 10-47
 Fuses 10-24
 Engine Compartment
 Fuse Block 10-25
 Instrument Panel Fuse
 Block 10-27

G

Gauges	
Fuel	5-12
Indicator	5-15
Mileometer	5-10
Rev Counter	5-11
Speedometer	5-10
Transmission Display	5-15
Glove Box	4-2

H

Hands-Free Phone	7-49
Hazard Lights	6-3
Head Restraints	3-1
Headlamp Range Adjustment	6-2
Headlamps	10-19
Bulb Replacement	10-19
Daytime Running Lamps (DRL)	6-3
Flash-to-Pass	6-2
Main-Beam On Light	5-19
Main/Dipped Beam Changer	6-1
Range Adjustment	6-2
Headlights When Driving	
Abroad	6-3

Heated Rear Window	2-16
Heated Front Seats	3-6
Heated Mirrors	2-12
Heating	8-1
Heating and Ventilation System	8-1
Horn	1-12, 5-3

I

Identification Plate	12-1
Ignition Positions	9-2
Immobiliser	2-9
Indicator	5-15
Indicators	
Control	5-12
Information Service	11-1
Information on Loading the Vehicle	4-7
Instrument Panel	
Overview	1-6
Storage Area	4-1
Interior Lamps	6-5

Interruption of Power Supply	9-8
Introduction	iii, 7-1
ISOFIX Child Restraint Systems	3-21

J

Jump Starting	10-48
---------------	-------

K

Keys	2-1
------	-----

L

Lamps	
Daytime Running (DRL)	6-3
Exterior Controls	6-1
Front Fog	6-4
Interior	6-5, 10-23
Malfunction Indicator	5-17
Number Plate	10-23
Rear Fog	6-4
Reversing	6-4
Side Indicator	10-22
Taillights	10-21

Light
 Electronic Stability Control
 (ESC), Off 5-18
 Lighter, Cigarette 5-7
 Lights
 Airbag and Safety Belt
 Tensioner 5-16
 Airbag On-Off 5-16
 Antilock Brake System
 (ABS) Warning 5-17
 Brake System Warning 5-17
 Charging System 5-17
 Door Ajar 5-20
 Engine Coolant
 Temperature Warning 5-18
 Engine Oil Pressure 5-19
 Flash-to-Pass 6-2
 Fog Lamp, Rear 5-20
 Front Fog Lamp 5-19
 Low Fuel Warning 5-19
 Main-Beam On 5-19
 Main/Dipped Beam Changer ... 6-1
 Overdrive Off 5-18

Lights (cont'd)
 Seat Belt Reminders 5-15
 Tyre Pressure Monitoring
 System 5-18
 Up-Shift 5-17
 Lights, Hazard 6-3
 Load Compartment 4-4
 LoadCompartment 2-6
 Loading the Vehicle 4-7
 Locks
 Central Locking System 2-4
 Low Fuel Warning Light 5-19

M

Main-Beam On Light 5-19
 Maintenance
 Air Conditioning Regular
 Operation 8-12
 Maintenance and Care
 Additional 11-7
 Maintenance Schedule 11-2
 Recommended Fluids and
 Lubricants 11-7
 Malfunction Indicator Lamp ... 5-17
 Manual Gearbox 9-9
 Manual Mirrors 2-10

Manual Windows 2-13
 Mileometer 5-10
 Mirrors
 Convex 2-10
 Folding 2-11
 Heated 2-12
 Manual 2-10
 Manual Rearview 2-12
 Power 2-11
 Monitor System, Tyre
 Pressure 10-32

N

Net, Convenience 4-6
 New Vehicle Run-In 9-2

O

Oil
 Engine 10-9
 Pressure Light 5-19
 Operation, Infotainment
 System 7-7
 Other Service Items
 Air Conditioning System 8-5
 Outlets
 Power 5-7

Overdrive Off Light 5-18
Overview, Infotainment
System 7-3

P

Parking 9-3
Brake 9-12
Parking Assist 9-14
Passenger Compartment Air
Filter 8-11
Performance 12-4
Personalisation
Vehicle 5-23
Phone
Bluetooth 7-44
Hands-Free 7-49
Power
Mirrors 2-11
Outlets 5-7
Protection, Battery 6-5
Steering Fluid 10-14
Windows 2-14
Pressure
Tyre 12-9

Privacy
Radio Frequency
Identification (RFID) 13-2

R

Radio
Personalisation 7-40
Radio Frequency
Identification (RFID) 13-2
Radio Remote Control 2-2
Radios
AM-FM Radio 7-11
Rear Fog Lamp Light 5-20
Rear Fog Lamps 6-4
Rear Window Washer/Wiper 5-5
Rear Windows
Heated 2-16
Rearview Mirrors 2-12
Recommended Fluids and
Lubricants 11-7
Remote Control
Radio 2-2
Repair Kit
Tyre 10-43
Rev Counter 5-11
Reversing Lamps 6-4

Ride Control Systems 9-13
Electronic Stability (ESC) 9-13
Roof Rack System 4-7
Rotation, Tyres 10-37
Running-In, New Vehicle 9-2

S

Safety Belts 3-6
Child Restraints 3-19
Three-Point 3-8
Seat Belts
Reminders 5-15
Seats
Adjustment, Front 3-4
Head Restraints 3-1
Heated Front 3-6
Position, Front 3-3
Selector Lever 9-5
Service 8-12
Accessories and
Modifications 10-2
Doing Your Own Work 10-3
Engine Soon Light 5-17
Service and Maintenance
Service Information 11-1
Service Information 11-1

Side Airbag System 3-13
 Side Indicator Lamps 10-22
 Signals, Turn and Lane-Change 6-4
 Spare Tyre
 Compact 10-46
 Specifications and Capacities 12-8
 Speedometer 5-10
 Starting the Engine 9-3
 Steering
 Fluid, Power 10-14
 Wheel Adjustment 5-2
 Wheel Controls 5-2
 Storage
 Load Compartment 2-6, 4-4
 Vehicle 10-2
 Storage Areas
 Convenience Net 4-6
 Glove Box 4-2
 Information on Loading the Vehicle 4-7
 Instrument Panel 4-1
 Roof Rack System 4-7
 Storage Compartments 4-1
 Sun Visors 2-17

Switches
 Airbag On-Off 3-16
 System
 Roof Rack 4-7

T

Taillights 10-21
 Technical Data
 Tyre Pressure 12-9
 Theft-Deterrent Systems
 Immobiliser 2-9
 Thread Depth 10-37
 Three-Point Safety Belt 3-8
 Time 5-6
 Tools 10-30
 Top Tether Child Restraint Systems 3-24
 Towing
 Another Vehicle 10-52
 Vehicle 10-49
 Transmission
 Automatic 9-4
 Fluid, Automatic 10-10
 Transmission Display 5-15
 Trip Computer 5-20

Turn and Lane-Change Signals 6-4
 Tyre Pressure 12-9
 Tyre Pressure Monitoring System Light 5-18
 Tyre Repair Kit 10-43
 Tyres
 Chains 10-42
 Compact Spare 10-46
 Designations 10-30
 Different Size 10-38
 Full-Size Spare 10-47
 Inflation Monitor System 10-33
 Pressure Monitor System 10-32
 Rotation 10-37
 Wheel Alignment and Tyre Balance 10-39
 Wheel Replacement 10-39
 Winter 10-30
 Tyres and Wheels 10-30

U

- Up-Shift Light 5-17
- Using This Manual iii

V

- Vehicle
 - Control 9-1
 - Identification
 - Number (VIN) 12-1
 - Personalisation 5-23
 - Towing 10-49
 - Towing Another Vehicle 10-52
- Vehicle Care
 - Tyre Pressure 10-31
- Vehicle Dimensions 12-7
- Vehicle Identification
 - Plate 12-1
- Vehicle Recovery
 - End-of-Life 10-3
- Vehicle Storage 10-2
- Vehicle Weight 12-6
- Ventilation
 - Adjustable Air 8-9
 - Fixed Air Vents 8-10
- Visors 2-17

W

- Warning
 - Brake System Light 5-17
- Warnings iii
 - Cautions and Danger iii
 - Hazard Lights 6-3
- Washer Fluid 10-15
- Weights
 - Vehicle 12-6
- Wheel Covers 10-38
- Wheels
 - Alignment and Tyre
 - Balance 10-39
 - Different Size 10-38
 - Replacement 10-39
- Wheels and Tyres 10-30
- Windows
 - Heated, Rear 2-16
 - Manual 2-13
 - Power 2-14
- Windscreen
 - Wiper/Washer 5-3
- Winter Tyres 10-30
- Wiper Blade Replacement 10-18
- Wipers
 - Rear Washer 5-5