

CONTENTS

INTRODUCTION TO CNG 3
SAFETY PRECAUTIONS (Do's & Don'ts) 3
LAYOUT OF THE CNG SYSTEM 4
FUEL MODES 5
SELECTOR SWITCH POSITION 5
PETROL MODE 5
AUTO MODE 6
FORCED CNG MODE 6
CNG LEVEL INDICATOR 6
CNG FILLER VALVE 7
CNG CYLINDER 7
MANUAL SHUT-OFF VALVE 8
TYRE REMOVAL 9
INSTRUMENT CLUSTER 10
CNG MALFUNCTION WARNING LAMP 11
CNG KIT IDENTIFICATION 11
CNG WARNING LABEL 12
FUSE BOX (under dashboard) 12
PERIODIC MAINTENANCE SCHEDULE 13
SPECIFICATIONS 14
LIST OF GOVERNMENT APPROVED CNG CYLINDER TESTING STATIONS 15
FIRE EXTINGUISHER (if equipped) 16
PARTS DESCRIPTION 17
REMOVAL PROCEDURE (from front seat) 17
PROCEDURE OF OPERATION 17
FITMENT PROCEDURE 18
REFILLING SCHEDULES 19

INTRODUCTION TO CNG:

CNG (Compressed Natural Gas) is principally constituted by methane. CNG is considered as clean burning fuel. Due to low density of CNG, it is compressed at a pressure of around 200 bars to enhance the vehicle on-board storage capacity.

CAUTION

In case of any symptom of CNG leakage or releasing noise or any external damage to CNG piping or during accident, do not panic.

- **Stop the vehicle and switch off the engine, roll down the windows and open all the doors**
- **Ensure to close manual shut off valve.**
- **Contact Maruti Suzuki authorized workshop immediatly for further assistance.**

SAFETY PRECAUTIONS (Do's):

1. If any service or body repair is to be carried out, turn the manual shut off valve on CNG cylinder valve to close position prior to commencement of the repair work.
2. Get the CNG cylinder checked every five (5) years from the date of last testing / retesting of cylinder by government authorized CNG cylinder testing agency.
3. If the vehicle does not changeover to CNG in AUTO MODE, then have your vehicle checked by Maruti Suzuki authorized workshop at the earliest.
4. Switch "OFF" engine while fuel filling (CNG/Petrol).
5. After refueling CNG or Petrol, ensure that the fuel filler lid is closed. (Otherwise vehicle cannot be started)
6. In AUTO MODE, It is programmed to start the vehicle in petrol and automatically shift to CNG based on the engine temperature etc. Do not press the accelerator pedal to change from petrol to CNG.

SAFETY PRECAUTIONS (Don'ts):

1. Do not change/modify the configuration, settings or the components from CNG system.
2. The CNG cylinder should not be repaired under any circumstances, in case of any problem, consult with Maruti Suzuki authorized workshop.
3. Do not adjust setting of CNG system.
4. Never install LPG or any other gas cylinder in place of CNG cylinder.
5. Avoid carrying inflammable material near the CNG cylinder.
6. Do not fill any other type of gas other than CNG.
7. Do not press the accelerator pedal to change from petrol to CNG MODE.

FOR VEHICLES FITTED WITH CNG FUEL SYSTEM

LAYOUT OF THE CNG SYSTEM

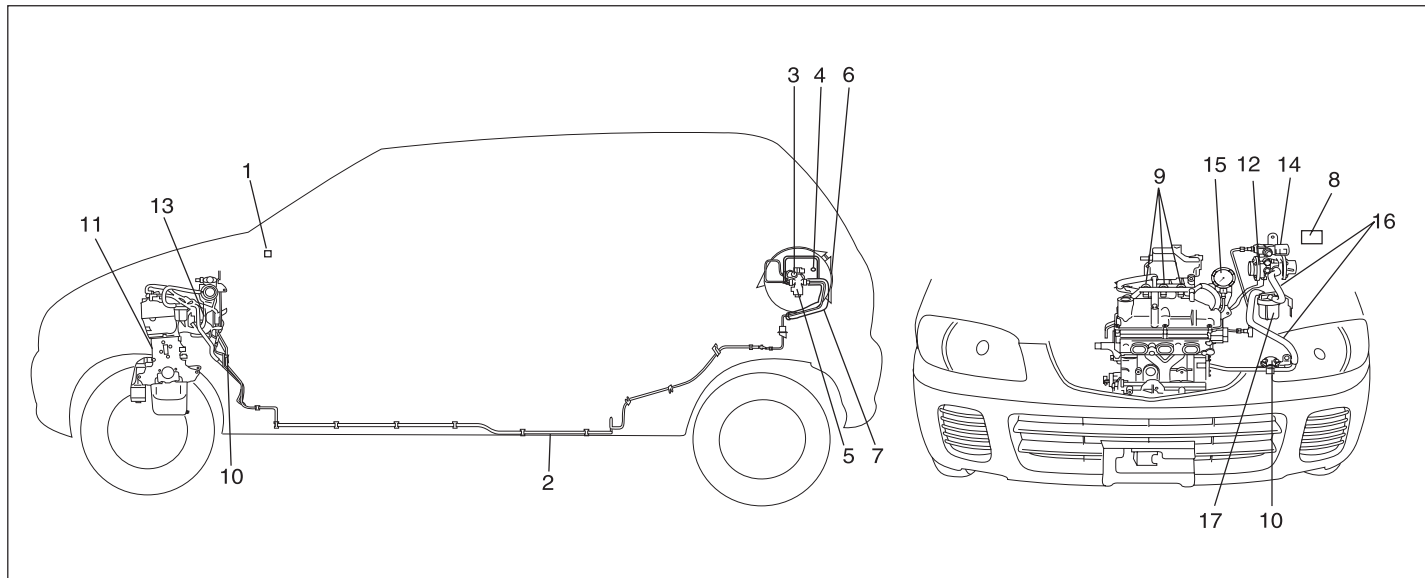

- 1 Changeover switch
- 2 High pressure pipe
- 3 Receptacle
- 4 Fuel lid switch
- 5 CNG cylinder valve
- 6 CNG cylinder

- 7 Vent hose
- 8 CNG controller
- 9 CNG injectors
- 10 Low pressure & temperature sensor
- 11 Engine
- 12 Pressure regulator

- 13 Water hose
- 14 High pressure sensor
- 15 High pressure gauge
- 16 Low pressure hose
- 17 CNG filter

FOR VEHICLES FITTED WITH CNG FUEL SYSTEM

FUEL MODES

There are three fuel modes in the vehicle (Petrol, Auto and Forced CNG) which are selectable by pressing the selector switch (1) located on the right side of the steering wheel on the dashboard.

⚠ WARNING

Make sure that the parking brake is applied fully and the transmission is in Neutral before attempting to start the engine.

CAUTION

- **Stop turning the starter immediately after the engine has started or the starter system can be damaged.**
- **Do not crank the engine for more than 15 seconds at a time. If the engine doesn't start on the first try, wait about 15 seconds before trying again.**

NOTE:

- *Do not press the accelerator pedal to changover from petrol to CNG model.*
- *With ignition switch "ON" and engine not running, blinking of CNG malfunction warning lamp indicates that fuel lid is open. Vehicle will not start in this condition.*

SELECTOR SWITCH POSITION

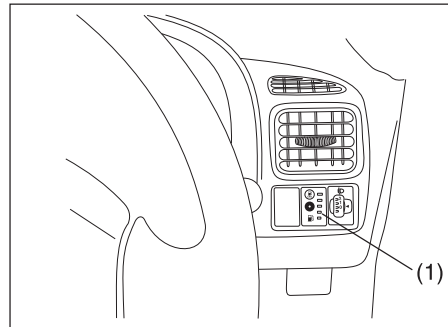

PETROL MODE

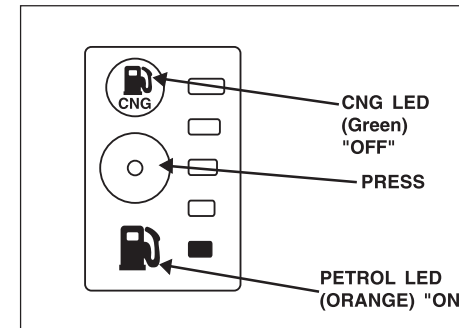

In this mode vehicle starts in petrol and continue running in petrol mode. In this mode, petrol indicator glows continuously in ORANGE color and CNG indicator (GREEN) will remain "OFF".

FOR VEHICLES FITTED WITH CNG FUEL SYSTEM

AUTO MODE

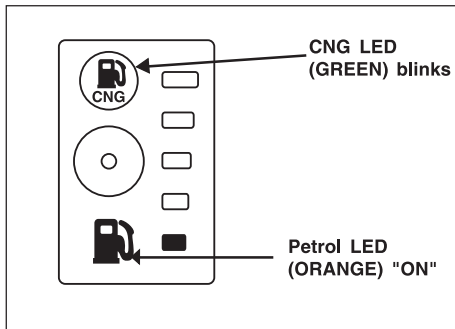

In this mode engine starts in petrol mode and then automatically changes to CNG after reaching programmed warming up condition. With ignition switch ON and vehicle started in "AUTO MODE", CNG indicator blinks (Green Color), and PETROL indicator glows (Orange color) continuously. After changeover to CNG, CNG indicator will glow continuously and Petrol indicator switches OFF automatically.

NOTE:

It is always recommended to start the vehicle in AUTO MODE or PETROL MODE to enhance the engine life.

FORCED CNG MODE

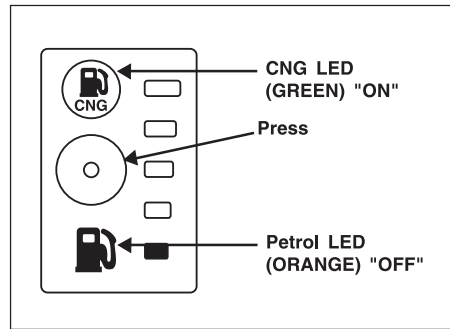

This is emergency mode and may be used in cases where there is no petrol in petrol tank. In this mode vehicle starts in CNG and continues running in CNG mode. With ignition "ON" and engine not running, press and hold the changeover switch till CNG indicator glows continuously. In this mode, CNG indicator glows continuously in GREEN color and Petrol indicator (ORANGE) remains "OFF".

NOTE:

It is recommended to keep sufficient amount of petrol in the petrol tank.

CNG LEVEL INDICATOR (On Dashboard)

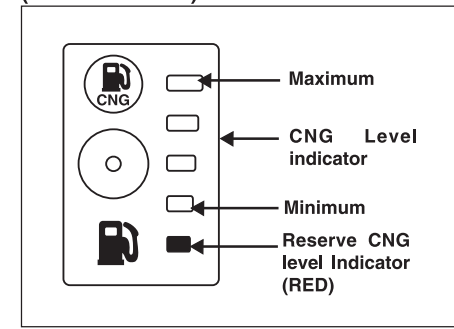

CNG level indicator is built into the changeover switch. It consists of four green and one red LEDs, which indicates approximate amount / level of remaining CNG in the cylinder. Red LED of CNG level indicator glows when reaches to reserve quantity.

NOTE:

- When CNG reserve level indicator glows, refill CNG as soon as possible.
- In case of CNG refilling, the updated CNG level indication will appear only when vehicle is running on CNG.

CNG FILLER VALVE

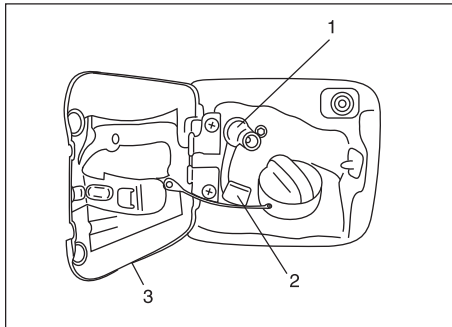

The CNG filler valve is integrated in fuel box next to petrol filling area.

CNG filler valve (1) can be uncovered by pulling out the Filler valve cover (2) and it can be covered by simply pushing it back.

Filling automatically gets cut off when the cylinder pressure becomes equal to dispenser pressure. After CNG filling, ensure that the filler valve cover (2) and fuel filler lid (3) is closed.

NOTE:

If the Fuel filler lid (3) is kept open, you will not be able to start the vehicle.

CNG CYLINDER

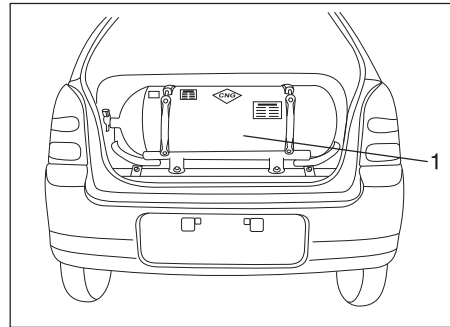

CNG cylinder (1) is installed in the luggage compartment.

CAUTION

Do not place any luggage or load over cylinder as it may damage the cylinder, pipe, hose, valve etc.

CNG CYLINDER WARNING LABEL

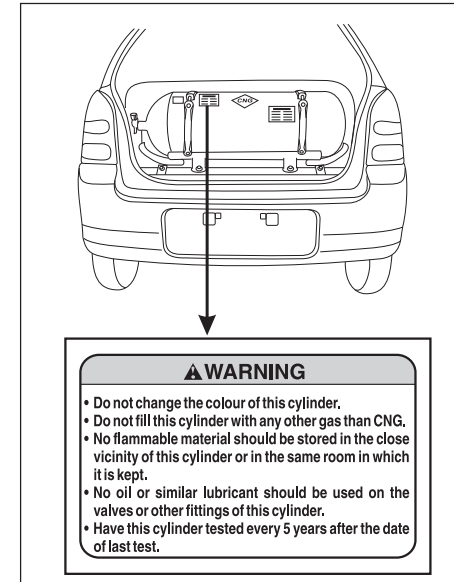

You may find this label on the CNG cylinder.

FOR VEHICLES FITTED WITH CNG FUEL SYSTEM

MANUAL SHUT-OFF VALVE

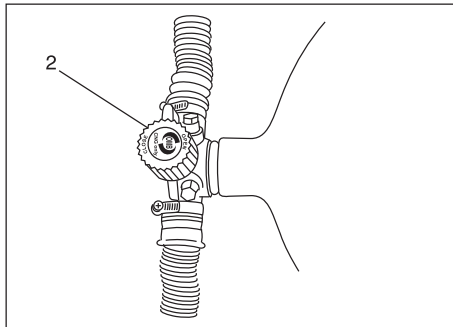

Manual shut-off valve (2) is located on the left hand side of the CNG cylinder.

MANUAL SHUT-OFF VALVE OPERATION

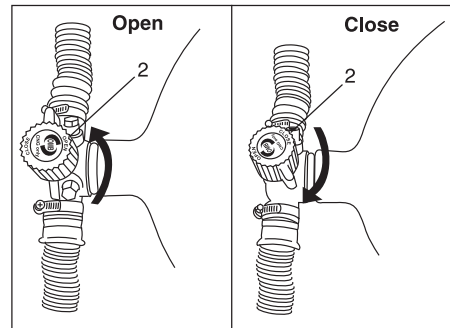

CNG supply can be switched off by closing the manual shut-off valve.

Valve closing: Turn the knob completely in clockwise direction to close the CNG supply to Engine.

Valve opening: Turn the knob completely in anti-clockwise direction to open the CNG supply to Engine.

NOTE:

- If the manual shut-off valve is not opened fully, then the engine may not run properly.
- If the manual shut-off valve is in closed condition, it is not possible to fill CNG into the cylinder.

NOTE:

- As per Government regulation, CNG cylinder needs to be checked and certified every five (5) years from the date of initial testing as mentioned on the CNG cylinder identification plate.
- Customer has to present the vehicle to a government approved testing agency.
- Failure to test the cylinder may result in denying of CNG filling by the CNG dispensing stations or may result in confiscating the vehicle by enforcement authorities.
- All the expenses for CNG cylinder testing has to be borne by the customer.
- As per Government regulation, CNG cylinder has to be discarded at 20 years from the date of initial testing as mentioned in the CNG cylinder identification plate.
- Customer has to discard the cylinder at his / her expense through government approved scrap agencies.
- No person shall refill any cylinder, which has been repaired under sub-rule (2) with any gas unless a full report on the repairs and test carried out on the cylinder, accompanied by the repairer's certificate of testing are furnished to the Chief Controller and his permission is obtained for its refilling.

TYRE REMOVAL (For CNG vehicles)

⚠ WARNING

- Never remove the cylinder valve from the cylinder assembly. For any assistance consult Maruti Suzuki authorized workshop.
- Never try to clean the cylinder. In case of any problem, contact Maruti Suzuki authorized workshop.
- Do not reuse the cylinder valve, once it is replaced / removed from cylinder assembly.
- Even if the CNG from the cylinder is consumed till engine stops, some amount of CNG will be left out in the tank under pressure.

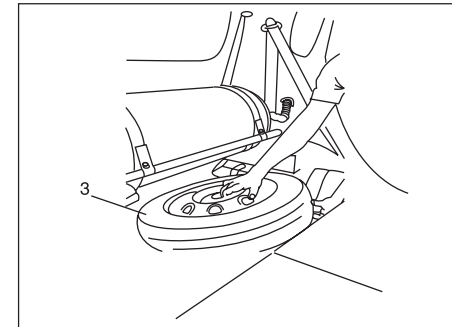
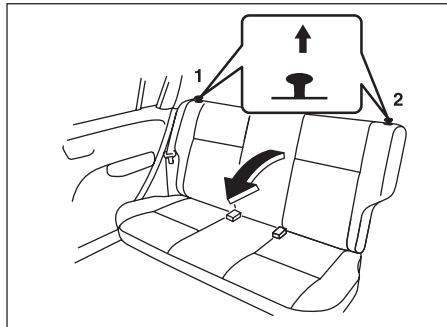

- Fold the rear seat by pulling the knob 1 and 2 together as shown, in order to access the spare wheel.
- Unscrew spare wheel screw in anti clockwise direction.
- Remove spare wheel (3) from the front side of vehicle as shown in the figure. Reverse the above procedure for fitting the spare wheel.

Note :

- Spare wheel can only be removed from the front side of the vehicle.
- It is recommended to remove the spare wheel first before removing the jack.

FOR VEHICLES FITTED WITH CNG FUEL SYSTEM

INSTRUMENT CLUSTER

- 1) Speedometer
- 2) Odometer / Tripmeter
- 3) Odometer / Tripmeter selector knob
- 4) Fuel Indicator
- 5) CNG malfunction warning Indicator lamp
- 6) Other warning and indicator lamps

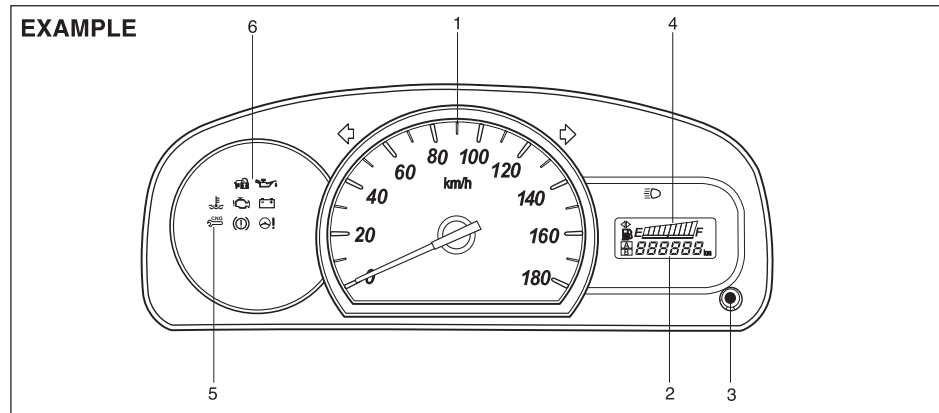

CNG MALFUNCTION WARNING LAMP



When the ignition switch is turned "ON", this CNG malfunction warning lamp comes on briefly, to check that the CNG malfunction lamp is troublefree.

- If CNG malfunction warning lamp glows continuously, with ignition "ON" there is some problem with the CNG system. Immediately get your vehicle checked by Maruti Suzuki authorized workshop.
- If CNG malfunction warning lamp blinks during engine running, it means there is some problem in CNG system in which vehicle cannot continue running in CNG MODE and automatically switchover to petrol mode. Have your vehicle checked at Maruti Suzuki authorized workshop.

NOTE:

With ignition switch "ON" and engine not running, blinking of CNG lamp indicates that fuel lid is open. Vehicle will not start in this condition. Close the lid in order to start the vehicle.

KIT IDENTIFICATION

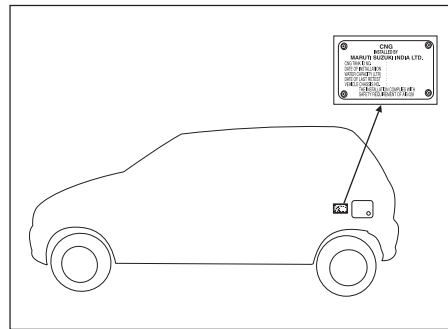

CNG cylinder identification number and CNG kit installation date is located on left side of fuel filling area.

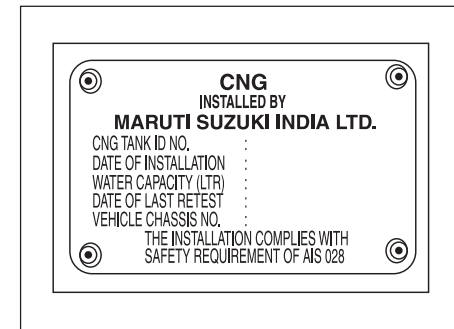

FOR VEHICLES FITTED WITH CNG FUEL SYSTEM

CNG WARNING LABEL

Front Driver Door

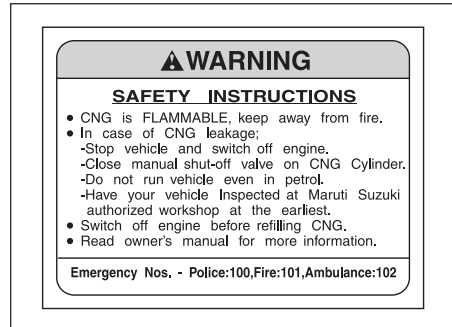
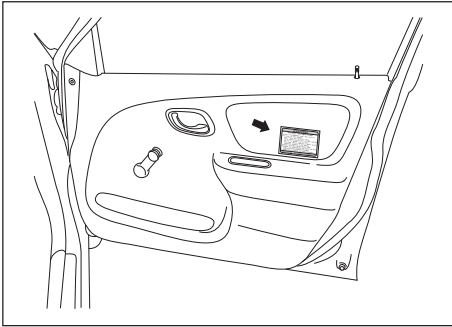

Rear Right Door

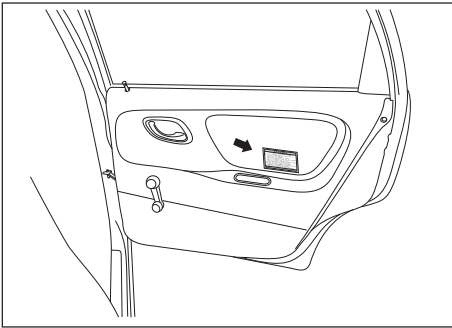

CNG warning label is located on front and rear Right doors.

FUSE BOX (under dashboard)

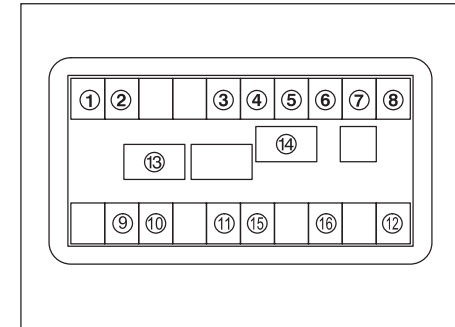

15) CNG Valve 7.5A

16) CNG 7.5A

For other fuses, refer "Inspection and maintenance" section in the main owner's manual.

FOR VEHICLES FITTED WITH CNG FUEL SYSTEM

PERIODIC MAINTENANCE SCHEDULE

Kms (1 x 1000)	1	5	10	20	30	40	50	60	70	80	90	100
Month	1	6	12	24	36	48	60	72	84	96	108	120
All Joints (Gas leakage)	I	I	I	I	I	I	I	I	I	I	I	I
Coolant Hoses (Leakage, Damage)	I	I	I	I	I	I	I	I	I	I	I	I
All Fasteners Torque values	T	T	T	T	T	T	T	T	T	T	T	T
CNG reducer filter cartridge with O-Ring	-	-	-	-	-	R	-	-	-	R	-	-
CNG low pressure filter cartridge with O-Ring	-	-	-	R	-	R	-	R	-	R	-	R

TTighten to Specific Torque

IInspect and correct or replace if necessary

RReplace

Note:

- *This table includes services as scheduled up to 100,000 km mileage. Beyond 100,000 km, carry out the same services at the same intervals respectively.*
- *For other maintenance details refer "Inspection & Maintenance" section in main Owner's Manual.*

FOR VEHICLES FITTED WITH CNG FUEL SYSTEM

SPECIFICATIONS

Mass (Weight) (Kgs)	
Kerb Weight	780-795 Kgs
Gross Weight	1140 Kgs
Seating Capacity	4 persons
Fuel Capacity (litres)	
Petrol	35 L
CNG (Water Filling Capacity)	60 L

NOTE:

Specifications are subject to change without notice.

NOTE:

- 1) It is recommended to run the vehicle on petrol mode for 5~10 kms after every 300~500 km run in CNG mode to keep fuel system in good condition.*
- 2) Always keep minimum 5 litres of petrol in your petrol tank.*

FOR VEHICLES FITTED WITH CNG FUEL SYSTEM

LIST OF APPROVED CNG CYLINDERS TESTING STATION

- **M/S Uttam Special GASSES Pvt. Ltd.,**
F-90/5, Okhla industrial Area, Phase-1,
New Delhi-110020
- **M/S Asco Industrial corporation,**
7A, Industrial estate Sonipat-131001
(Haryana)
- **M/S Gas Authority of India Ltd. 16,**
Bhikaji cama Place ,R.K Puram,
New delhi-66
- **M/S Bharat Pump and Compressors Ltd**
Naini, Allahabad.
- **M/S Teesta Construction Pvt. Ltd.**
687, (G) Sector-28, Noida 201303, Gauram
Bud Nagar (UP).
- **M/S Maruti Koatsu Cylinder Pvt. Ltd**
1402, GIDC.Industrial state, Dist. Panch-
mahal Halol-389351
- **M/S Asiatic Oxygen and Gases Ltd.**
Pokhran Road, Thane.
- **M/S S.V Tanks and Vessels Ltd**
Plot No. C/100, MIDC Industrial Area,
Turbhe, New Mumbai-400613
- **M/S Jarakahi Automobile Pvt Ltd 19/1,**
Samart Silk Mill Corpound, LBS Marg,
Vikhroli(W), Mumbai-400079
- **M/S Green Globe Technical Service ,**
Plote No 151, Brick factory Compound,
Shastri Nagar, Mulund Colony, Mulund (W),
Mumbai-400082
- **M/S Metro Cylinder Testing Co.**
72/10, 26 km Stone Rohtak Road, Mundka
Udhyog Nagar, Ghevra Extn. New Delhi-41
- **M/S Hi -Tech CNG Cylinder Test House**
30, Netaji Subhash Marg, New Delhi-110002
- **M/S Jiolat Auto Gas Industries**
2094/G-5, gali No. Pre Nagar (Zakhira), New
Delhi-110008
- **M/S JBM Industries Ltd.**
Plot No. 269, Sector-24, Faridabad-121005
- **M/S Maruti Koatsu Cylinder Pvt. Ltd**
1402, GIDC Indl. Area Halol-389350 (Guj.)
- **M/S Satyam CNG Cylinder Test House,**
Khasra No. 21/1, Jharoda Majra Burari,
Delhi-110084

FOR VEHICLES FITTED WITH CNG FUEL SYSTEM

FIRE EXTINGUISHER (if equipped)

Do's and Don'ts

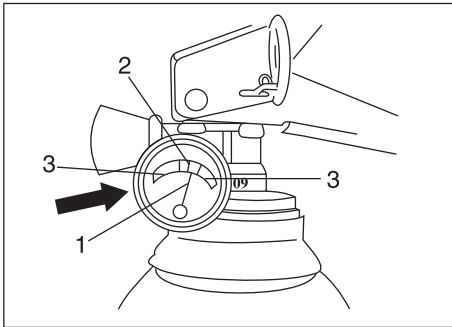

Do's

1. Check pressure gauge periodically. Max charging pressure is 15Kgf/cm² (in green zone (2)).
2. When pressure drops, indicator needle (1) will shift to the red zone (3). Immediately contact Maruti Suzuki authorized workshop for inspection / refilling.
3. Get the fire extinguisher serviced, only through Maruti Suzuki authorized workshop.
4. Ensure that the Fire extinguisher is always kept at its prescribed position in the vehicle.
5. Refill the fire extinguisher immediately after use.

Don't

- Do not use water for cleaning fire extinguisher. (Use clean cloth for removing dust)
- Do not rely on used or discharged fire extinguisher.

LOCATION

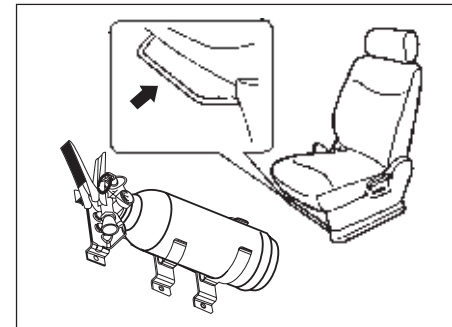

Fire extinguisher is located below co-passenger's seat.

FOR VEHICLES FITTED WITH CNG FUEL SYSTEM

PARTS DESCRIPTION

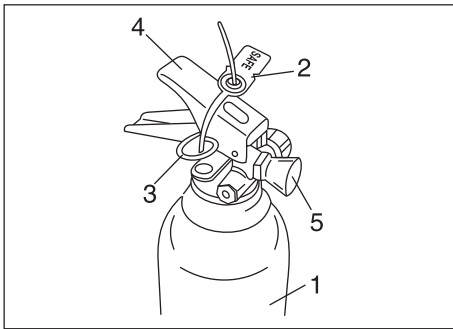

- 1) Fire extinguisher cylinder
- 2) Seal
- 3) Safety Pin
- 4) Lever
- 5) Nozzle

REMOVAL PROCEDURE (from front seat)

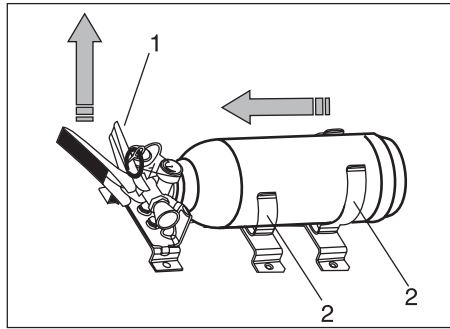

Lift Lever (1) of fire extinguisher slightly upwards and pull the fire extinguisher in the direction as shown in the figure, in order to disengage it from clamps (2).

PROCEDURE OF OPERATION



- 1. Hold the fire extinguisher (1) upright.
- 2. Break seal (2) by rotating the safety pin (3).

FOR VEHICLES FITTED WITH CNG FUEL SYSTEM

FITMENT PROCEDURE

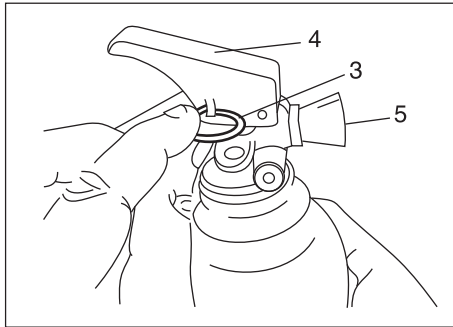

3. Pull Safety pin (3)
4. Squeeze lever (4) and direct the jet from nozzle (5) towards the near edge of the fire with a rapid (fast) sweeping motion.



5. Drive the fire towards the far edge until flames are extinguished.

NOTE:

Fire extinguisher is only meant for small fire caused in vehicle by external source only.

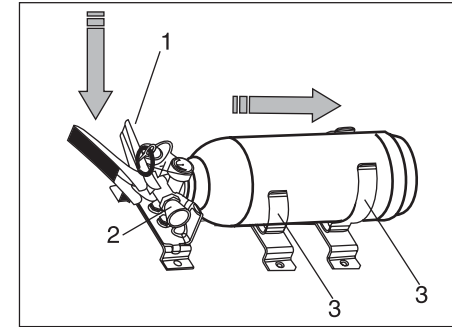

Insert the body of fire extinguisher (1) in to the clamps (3) and place the nozzle (2) carefully downwards, on the clamp

NOTE:

Ensure that the nozzle of fire extinguisher is properly seated on the clamp.

REFILLING SCHEDULES

1. Refilling is necessary after every use.
2. Fire extinguisher needs refilling after every 3 years even if it is not used.

