

# TABLE OF CONTENTS

MAINTENANCE SERVICE RECORD	1
WARRANTY POLICY	2
BEFORE DRIVING	3
STEERING COLUMN CONTROLS	4
INSTRUMENT PANEL	5
OTHER CONTROLS AND EQUIPMENT	6
OPERATING YOUR VEHICLE	7
DRIVING TIPS AND SAFE DRIVING	8
INSPECTION AND MAINTENANCE	9
EMERGENCY SERVICE	10
BODY WORK CARE	11
GENERAL INFORMATION	12
SPECIFICATIONS	13



## FOREWORD

*This manual is an essential part of your vehicle and should be kept with the vehicle at all times. Please read this manual carefully and review it from time to time. It contains important information on safety, operation, and maintenance. It is especially important that this manual remain with the vehicle at the time of resale. The next owner will need this information also.*

*You are invited to avail the three free inspection services as described in this manual. Three free inspection coupons are attached to this manual. Please show this manual to your dealer when you take your vehicle for any service.*

*To prolong the life for your vehicle and reduce maintenance cost, the periodic maintenance must be carried out according to the "PERIODIC MAINTENANCE SCHEDULE" described in "INSPECTION AND MAINTENANCE" section of this manual. Periodic maintenance is essential for preventing trouble and accidents to ensure your satisfaction and safety.*

*Daily Inspection and Care as per "DAILY INSPECTION CHECKLIST" described in the "INSPECTION AND MAINTENANCE" section of this Manual is essential for prolonging the operating life of the vehicle and for safe driving.*

MARUTI SUZUKI INDIA LIMITED believes in conservation and protection of Earth's natural resources.

To that end, we encourage every vehicle owner to recycle, trade in, or properly dispose of, as appropriate, used motor oil, coolant, and other fluids; batteries; and tyres.

### MARUTI SUZUKI INDIA LIMITED

**All information in this manual is based on the latest product information available at the time of publication. Due to improvements or other changes, there may be discrepancies between information in this manual and your vehicle. Maruti Suzuki reserves the right to make changes at any time without notice.**

**This vehicle may not comply with standards or regulations of other countries. Before attempting to register this vehicle in any other country, check all applicable regulations and make any necessary modifications.**

## IMPORTANT

### WARNING/CAUTION/NOTE

*Please read this manual and follow its instructions carefully. To emphasise special information, the words WARNING, CAUTION, and NOTE have special meanings. Information following these signal words should be carefully reviewed.*

#### WARNING

**The personal safety of the driver, passengers, or bystanders may be involved. Disregarding this information could result in their injury or death.**

#### CAUTION

**These instructions point out special service procedures or precautions that must be followed to avoid damaging the vehicle.**

#### NOTE:

*This provides special information to make maintenance easier or important instructions clearer.*

## MODIFICATION WARNING

### ⚠ WARNING

Do not modify this vehicle. Modification could adversely affect safety, handling, performance, or durability and may contravene regulations. In addition, damage or performance problems resulting from modification may not be covered under warranty.

### ⚠ WARNING

Your vehicle has monocoque body construction which provides for certain crumple zones in the body which absorbs larger part of impact energy in the event of a front collision and protects the occupants from impact. Do not use any fitments such as crash guards. These fitments will increase the risk to the occupants because of the shock directly getting transmitted to the occupants.

### CAUTION

Improper installation of mobile communication equipment such as cellular telephones or CB (Citizen's Band) radios may cause electronic interference with your vehicle's ignition system, resulting in vehicle performance problems. Consult your MARUTI SUZUKI dealer or qualified service technician for advice on installing such mobile communication equipment.

Copying, quoting or reproduction of any part of this manual is not permitted without explicit approval by **MARUTI SUZUKI INDIA LIMITED**.

**VEHICLE DETAILS**

MODEL	CHASSIS NO.	ENGINE NO.	KEY NO.	DATE OF DELIVERY	ODOMETER REDATING	BATTERY	
						MAKE	SR. NO/BATCH CODE
					km.		

OWNER'S NAME & ADDRESS _____ _____ TEL. NO. _____
--

ADDRESS/STAMP OF SELLING DEALER	SELLING DEALER CODE
SHOWROOM	
WORKSHOP	<b>IMPORTANT INFORMATION TO CUSTOMER</b>  Dear Customer For any assistance with regard to our product, please contact General Manager/Works Manager at any of our Dealer or Authorised Service Station. For additional enquiry you may contact our Regional Office or Service Department. The Addresses and Phone nos. are given in Service Network Booklet provided alongwith vehicle.



## WARRANTY POLICY

Maruti Suzuki India Limited (hereinafter called "Maruti Suzuki "), warrants that each new Maruti Suzuki vehicle distributed in India by Maruti Suzuki and sold by an authorised Maruti Suzuki dealer will be free, under normal use and service, from any defects in material and workmanship at the time of manufacture SUBJECT TO THE FOLLOWING TERMS AND CONDITIONS:

### (1) Qualification:

To qualify for this warranty:

- (a) The Maruti Suzuki vehicle must be delivered by Maruti Suzuki authorised dealer and set-up, serviced by Maruti Suzuki authorised dealer/service station.
- (b) The warranty registration card in respect of each vehicle must be completed by the dealer at the time of delivery of the vehicle and dealer should retain the same.

### (2) Term:

**The term of the warranty shall be twenty four (24) months or 40,000 kilometers (whichever occurs first) from the date of delivery to the first owner.**

### (3) Maruti Suzuki 's Warranty Obligation:

If any defect(s) should be found in a Maruti Suzuki vehicle within the term stipulated above, Maruti Suzuki 's only obligation is to repair or replace at its sole discretion any part shown to be defective, with a new part or the equivalent at no cost to the owner for parts or labour, when Maruti Suzuki acknowledges that such a defect is attributable to faulty material or workmanship at the time of manufacture. The owner is responsible for any repair or replacements which are not covered by this warranty.

### (4) Limitation:

This warranty shall not apply to:

- (a) normal maintenance service required other than the three free services, including without limitation, oil and fluid changes, headlight aiming, fastener retightening, wheel balancing, wheel alignment and tyre rotation, cleaning of injectors, adjustments of carburettor, ignition timing, clutch and valve clearance.
- (b) the replacement of normal wear parts including without limitation, bulbs, tyres and tubes, spark plugs, belts, hoses, filters, wiper blades, brushes, contact points, fuses, clutch disc, brake shoes, brake pads, cable and all rubber parts (except oil seal and glass run).
- (c) any vehicle which has been used for competition or racing.
- (d) any repairs or replacement required as a result of accidents or collision.
- (e) any defects caused by misuse, negligence, abnormal use or insufficient care.
- (f) any vehicle which has been modified or altered, including without limitation, the installation of performance accessories.
- (g) any vehicle on which parts or accessories not approved by Maruti Suzuki have been used.
- (h) any vehicle which has not been operated in accordance with the operating instructions in the Maruti Suzuki Owner's Manual.
- (i) any vehicle which has not received, during the warranty term, the service inspections prescribed in the Maruti Suzuki Owner's Manual.
- (j) any vehicle which has been assembled, disassembled, adjusted or repaired by other than an Maruti Suzuki authorised dealer/service station.

- (k) any vehicle which has been used for purposes other than what it was designed for.
- (l) any damage or deterioration caused by industrial pollution and bird droppings.
- (m) insignificant defects which do not affect the function of the vehicle including without limitation sound, vibration and fluid seep.
- (n) any natural wear and tear including without limitation, aging etc.
- (o) Installation and usage of Domestic LPG Gas/LPG cylinder.
- (p) V-belts, hoses and gas leaks. (For Maruti Suzuki AC Vehicle.)
- (q) Any vehicle retrofitted with LPG/CNG kits.

**(5) Extent of Warranty:**

This warranty is the entire written warranty given by Maruti Suzuki for Maruti Suzuki vehicles and no dealer or its or his agent or employee is authorised to extend or enlarge this warranty and no dealer or its or his agent or employee is authorised to make any oral warranty on Maruti Suzuki 's behalf.

Maruti Suzuki reserves the right to add any improvements or change the design of any model at any time with no obligation to make the same changes on units previously sold.

**(6) Warranty Service:**

To obtain warranty service, the complete vehicle must be presented at the owner's expenses to any authorised Maruti Suzuki dealer.

**(7) Owner's Warranty Responsibilities:**

It is responsibility of each owner to:

- (a) make certain that the warranty registration/PDI card was completed at the time of delivery of the vehicle;
- (b) have performed, at his own expenses, by an Maruti Suzuki authorised dealer/service station all the service inspections specified in the Maruti Suzuki "Owner's Manual and Service Booklet" and maintain adequate proof that such service inspections have been performed.
- (c) make certain that the Maruti Suzuki authorised dealer/service station performing the service inspection has certified the work on the "Maintenance Service Record" page in the "Owner's Manual and Service Booklet" and
- (d) present the Maruti Suzuki "Owner's Manual and Service Booklet" to the authorised Maruti Suzuki dealer whenever requesting service inspections or warranty service.

If the "Owner's Manual and Service Booklet" should be lost or destroyed the owner should consult the authorised Maruti Suzuki dealer from whom the vehicle was purchased for instructions concerning replacement of the "Owner's Manual and Service Booklet".

**(8) Disclaimer of Consequential Damage:**

Maruti Suzuki assumes no responsibility for loss of vehicle, loss of time, inconvenience or any other indirect incidental or consequential damage resulting from the vehicle not being available to the owner because of any defect covered by this warranty.

**(9) Change of Owner**

Even if ownership of the vehicle changes, the remaining warranty period is effective for the new owner.



Maruti Suzuki offers the Emission Warranty on all Maruti Suzuki vehicles (aparts from the Regular Warranty and will run parallel to the regular product warranty) only in four metropolitan cities (**New Delhi, Kolkatta, Mumbai and Chennai**) with effect from **July 1st, 2001**.

**Terms:**

The Emission Warranty will be applicable for **80,000 kms or 3 years** (Whichever comes earlier) from the date of delivery to the first owner. The remaining warranty terms will be valid in case of any change in ownership provided the production of all valid documents.

**Conditions :**

1. Under Emission Warranty, Warranty claims will be admitted for a prima facie examination, in case vehicle fails to meet to the Emission Standard as specified *in sub rule (2) of rule no. 115 of Central Motor Vehicles Rules (CMVR), 1989.*
2. The warranty claims will only be accepted after examination carried out by Maruti Suzuki or it's dealer which leads to firm conclusions that the
  - a) Original settings have not been tempered in any case.
  - b) Part (as given in Annexure-A) has a manufacturing defect.
  - c) Vehicle is unable to meet the Emission Standards (as given in 1.), inspite of the vehicle having been maintained and used in accordance with the instructions as specified in Owner's Manual and Service Booklet and the used fuel and different oils (Engine oil, Transmission oil, Brake oil etc.) are also as per specification.
3. The method of examination for deciding the warranty of the parts will be at the sole discretion of Maruti Suzuki and it's dealer and results of the examination will be final and binding. If after examination, the warrantable condition is not established, Maruti Suzuki and it's dealer has the right to charge all, or part of the cost of such examination.
4. Under Emission Warranty, the parts (as given in Annexure-A) will be changed free of cost, but the consumables will be charged as per actual.
5. If the part covered under Emission Warranty or the associated parts, are not independently replaceable, on account of these being integral parts of a complete assembly, Maruti Suzuki and it's dealer will have the sole discretion to replace either the entire assembly or by using some of the parts of the system through suitable repairs or modifications.

## **EMISSION WARRANTY**

797-74E-I

6. Any consequential repairs or replacement of parts which may be found necessary to establish compliance of Emission Warranty, will not be considered under warranty, unless the same is under product warranty. The consumable will be charged as per actual under such repair or replacement.
7. Maruti Suzuki will not be responsible for the cost of transportation of the vehicle to the nearest Maruti Suzuki dealer workshop or any loss due to non-availability of the vehicle during the period of lodging of a warranty claim and examination and/or repair by Maruti Suzuki dealer.
8. Maruti Suzuki will not responsible for any penalty that may be charged by statutory authorities on account of failure to comply with the EMISSION STANDARDS.
9. Emission Warranty will not be affected on the change of owner, provided all the documents are available.
10. All maintenance actions (as specified in the Owner's Manual and Service Booklet) need to be followed and recorded in the manual for emission warranty.
11. The customer needs to produce the PUC (Pollution Under Control) certificate valid for the period preceding the test during which the failure is discovered. The receipts (for the maintenance of the vehicle as per specification in Owner's Manual and Service Booklet from the date of original purchase of the vehicle) will also be required.

### **Conditions under which the Emission Warranty is not APPLICABLE**

1. In the absence of valid PUC certificate.
2. Vehicle not serviced from Maruti Suzuki authorised workshop as per the schedule specified in the Owner's Manual .
3. Vehicle subjected to abnormal use (accident, motor race, rallies or for the purpose of establishing the records etc.)
4. Use the non MGP (Maruti Genuine Part).
5. Vehicle tempered in an unauthorised manner.
6. Tampering with odometer so that the actual kilometer reading can not be read.
7. Use of adulterated fuel and/or unspecified oils (Engine oil, Transmission oil and Brake oil etc.)

**Annexure-A**

List of parts covered under Emission Warranty

1. Fuel Injection Assembly, Pressure Regulator, Throttle Body Assembly.
2. Electronic Control Module (ECM).
3. Intake Manifold.
4. EGR valve.
5. Distributor and internal parts.
6. Ignitions Coil.
7. Canister Assembly.
8. Vapour Liquid Separator.
9. Fuel Tank and Filler Cap.
10. PCV (Positive Crankcase Ventilation) Valve.
11. Oil Filler Cap.
12. Catalytic Convertor.
13. Exhaust Manifold.
14. All fuel Injection System related SENSORS.
15. Manivertor



## BEFORE DRIVING

Fuel Recommendation .....	3-1
Keys .....	3-2
Immobilizer Key (if equipped) .....	3-2
Door Locks (if equipped) .....	3-3
Windows .....	3-4
Mirrors .....	3-5
Driver's Seat Adjustment .....	3-5
Adjustable Head Restraints (if equipped) .....	3-6
Seat Belts .....	3-7

**BEFORE DRIVING**

797-74E-1

**FUEL RECOMMENDATION**

You **must use unleaded petrol** with an octane number (RON) of 91 or higher. Your vehicle is fitted with a restrictor in the fuel filter pipe which will not allow the use of large nozzle used for dispensing leaded fuel at filling station.

**CAUTION**

**Use of leaded fuel in vehicle equipped with catalytic converter is prohibited, because lead deactivates the pollutant-reducing components of catalytic converter and may result in permanent damage to catalytic converter.**

**Petrol/Ethanol Blends**

Blends of unleaded petrol and ethanol (grain alcohol), also known as gasohol, are commercially available in some areas. Blends of this type may be used in your vehicle if they are no more than 5% ethanol. Make sure this petrol-ethanol blend has octane ratings no lower than those recommended for petrol.

**Petrol/Methanol Blends**

Blends of unleaded petrol and methanol (wood alcohol) are also commercially available in some areas. **DO NOT USE** fuels containing more than 5% methanol under any circumstances. Fuel system damage or vehicle performance problems resulting from the use of such fuels are not the responsibility of MARUTI SUZUKI and may not be covered under Warranty.

Fuels containing 5% or less methanol may be suitable for use in your vehicle if they contain cosolvents and corrosion inhibitors.

**NOTE:**

*If you are not satisfied with the driveability or fuel economy of your vehicle when you are using a petrol/alcohol blend, you should switch back to unleaded petrol containing no alcohol.*

**CAUTION**

**Be careful not to spill fuel containing alcohol while refuelling. Fuels containing alcohol can cause paint damage, which is not covered under Warranty.**

**CAUTION**

**The fuel tank has an air space to allow for fuel expansion in hot weather. If you continue to add fuel after the filler nozzle has automatically shut off or an initial blowback full. Exposure to heat when fully fuelled in this manner will result in leakage due to fuel expansion. To prevent such fuel leakage, stop filling after the filler nozzle has automatically shut off, or when using an alternative non automatic system, Initial vent blowback occurs.**

**KEYS**

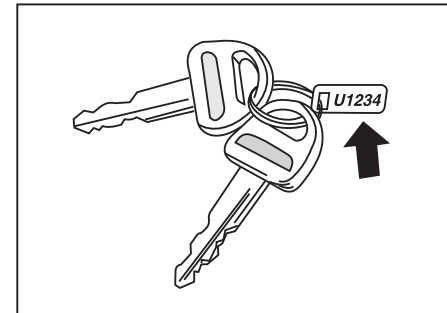

843-03-003

Your vehicle comes with a pair of identical keys, keep the spare key in a safe place. One key can open all of the locks on the vehicle.

The key Identification number is stamped on the keys. If you lose your keys, you will need this number to have new keys made. Write the number down and keep it in a safe accessible place away from the vehicle.

KEY NO.

<b>⚠ WARNING</b>
<ul style="list-style-type: none"> <li>• <b>Do not use locally made key.</b></li> <li>• <b>Should you require a duplicate key, place your order with a MARUTI SUZUKI dealer only.</b></li> </ul>

**NOTE:**  
Keep the spare key very carefully. When it is lost, consult your dealer by quoting key number.

**IMMOBILIZER KEYS (if equipped)**

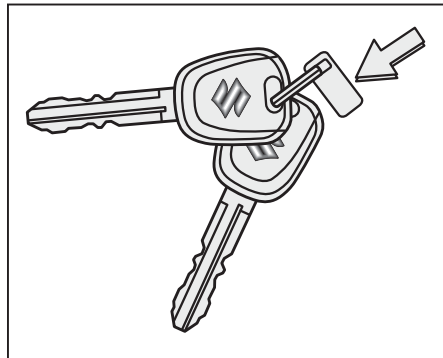

**Immobilizer System (if equipped)**

This system is designed to help prevent vehicle theft by electronically disabling the engine starting system.

The engine can be started only with your vehicle's original immobilizer ignition key which has an electronic identification code programmed into it. The key communicates the identification code to the vehicle when the key is turned to the "ON" position. If you need to make spare keys, contact your MARUTI SUZUKI dealer. The vehicle must be programmed with the correct identification code for the spare keys. A key made by an ordinary locksmith will not work.

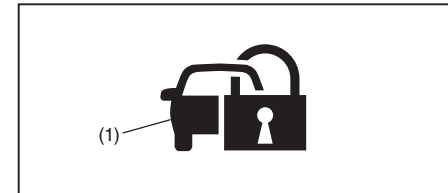

54G003

If the immobilizer system light (1) blinks when the ignition switch is in the "ON" position, there may be something wrong with your key or with the immobilizer system. Contact your MARUTI SUZUKI dealer to inspect the system.

**NOTE:**

- *If you lose your immobilizer ignition key, contact your MARUTI SUZUKI dealer as soon as possible to have the lost one deactivated, then have the new key made by them.*
- *If you own other vehicles with immobilizer keys, keep those keys away from the ignition switch when using your vehicle, or the engine may not be started because they may interfere with your vehicle's immobilizer system.*

**CAUTION**

In case of attaching any metal objects to the immobilizer key, it may not start the engine.

The immobilizer key is a sensitive electronic instrument. To avoid damaging the immobilizer key:

- Do not expose it to impacts, moisture or high temperature such as by leaving it on the dashboard under direct sunlight.
- Keep the immobilizer key away from magnetic objects.

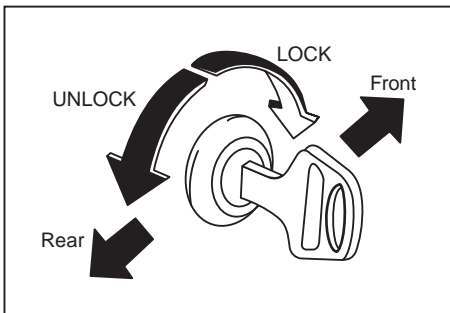

843-03-004E

**Front Right Door**

To lock the door from outside the vehicle:

- Insert the key fully and turn the top of the key toward the front of the vehicle, or
- Push in the lock lever and hold the door handle up as you close the door.

To unlock a front door from outside the vehicle, insert the key fully and turn the top of the key toward the rear of the vehicle.

**Front Left Door/Rear Sliding Door**

To lock the door from outside the vehicle, push in the lock lever and close the door.

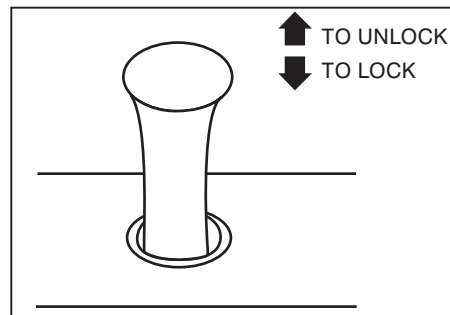

843-03-005E

To lock a dor from inside the vehicle, push in the lock lever. Pull out the lock lever to unlock the door.

**WARNING**

**Always lock al doors when driving**  
**Locking the door prevents occupants**  
**from being thrown from the vehicle in**  
**the event of an accident. it also helps**  
**prevent unientional opening of the**  
**doors.**

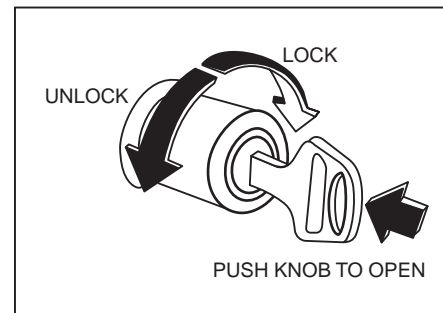

797-03-003E



**Back door**

To unlock, Insert the key into the lock Knob and turn it clockwise, and to lock, turn it anticlockwise. Backdoor can be opened by pushing in the lock Knob and lifting the grip.

**w WARNING**

Always make sure that the back door is closed and latched securely. Closing the back door completely helps keep exhaust gases from entering the vehicle. Completely closing the back door also helps prevent occupants from being thrown from the vehicle in the event of an accident.

**CAUTION**

In Omni Cargo don't attempt to open the rear right sliding door, from inside or outside.

**CAUTION**

Do not use the key to lift up the door, or the key may break off in the lock.

**WINDOWS**

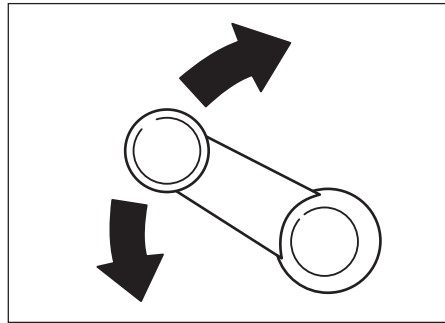

70F-01-010

**Front Door Window**

Raise or lower the door windows by turning the handle located on the door panel.

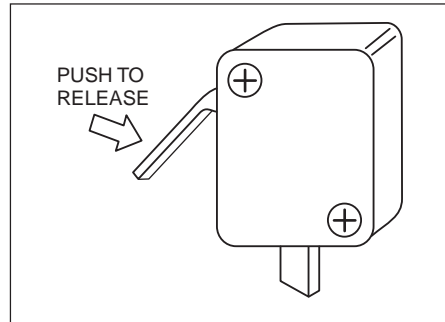

797-03-004E

**Sliding Door Window (If Equipped)**

Release the lock and simultaneously push the glass backwards to any desired open position. To lock the window, close the glass completely by pushing it forward.

**MIRRORS**

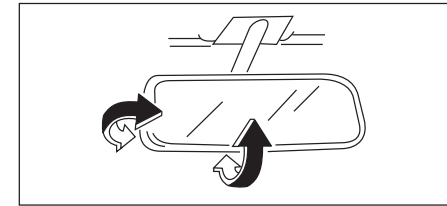

70F-01-013

**Inside Rearview Mirror**

To adjust the inside rearview mirror, move the mirror up, down, or sideways to obtain the best view.

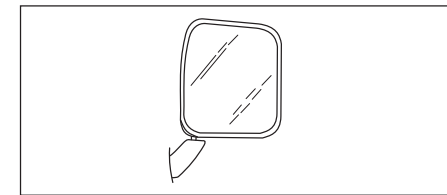

797-03-006

**Outside Rearview Mirror**

Adjust the outside rearview mirror so you can just see the side of your vehicle in the mirror.

**DRIVER'S SEAT ADJUSTMENT**

**⚠ WARNING**  
 Never attempt to adjust the driver's seat or seatback while driving. The seat or seatback could move unexpectedly, causing loss of control. Make sure that the driver's seat and seatback are properly adjusted before you start driving.



797-03-007

**Adjusting Driver's Seat Position**

The adjustment lever is located under the front of the seat, on the inboard side. To adjust the seat position, pull up on the adjustment lever and slide the seat forward or rearward. After adjustment, try to move the seat forward and rearward to ensure that it is securely latched.

**⚠ WARNING**  
 To avoid excessive seat belt slack, which reduces the effectiveness of the seat belt as a safety device, make sure that the seat is adjusted before the seat belt is fastened.

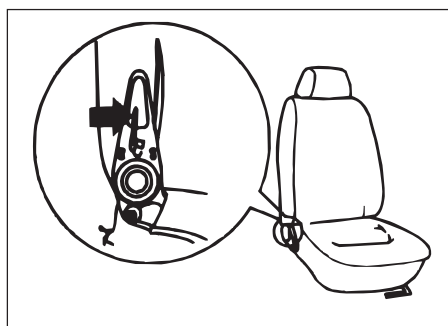

797-03-008

**Adjusting Seatbacks**

The seatbacks can be adjusted to different angles (5 Seater Models only). To adjust the seatback angle, push the lever on the outboard side of the seat, move the seatback to the desired position, and release the lever to lock the seatback in place. The seatbacks can also be folded forward.

**⚠ WARNING**  
 Seatbacks should always be in an upright position when driving, or seat belt effectiveness may be reduced. Seat belts are designed to offer maximum protection when seatbacks are in the fully upright position.

### ADJUSTABLE HEAD RESTRAINTS (if equipped)



70F-01-019

#### ⚠ WARNING

- **Never drive the vehicle with the head restraints removed.**
- **Do not attempt to adjust the head restraint while driving.**

Head restraints are designed to help reduce the risk of neck injuries in the case of an accident. Adjust the head restraint to the position which places the middle of the head restraint closest to the top of your ears.

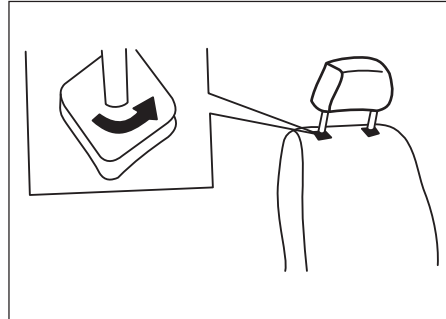

797-03-009

There are two height positions for the head restraints. To raise the head restraint, pull upward on the restraint until it clicks. To lower the restraint, push down on the restraint. If a head restraint must be removed (for cleaning, replacement, etc.), turn the portion as indicated with the arrow in illustration and pull the head restraint all the way out.

### SEATBELTS

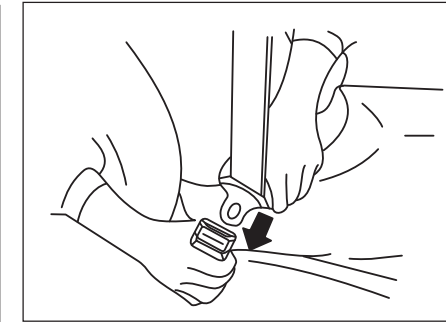

70F-01-021

#### ⚠ WARNING

**Wear Your Seat Belts at All Times.**

To fasten the seat belt, pull the buckle tongue attached to the seat belt across your body and slide it into the buckle catch slot on the opposite side until you hear a "click".

To reduce the risk of sliding under the belt during a collision, position the lap portion of the belt across your lap as low on your hips as possible and adjust the belt to a snug fit using the proper method described below. Make sure that the belt is not twisted.

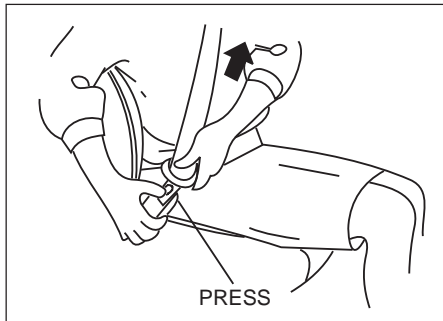

70F-01-023E

To unfasten the belt, press the release button on the buckle catch.



843E-01-005

**⚠ WARNING**

Be sure to inspect all seat belt assemblies after any collision. Any seat belt assembly which was in use during a collision (other than a very minor one) should be replaced, even if damage to the assembly is not obvious. Any seat belt assembly which was not in use during a collision should be replaced if it does not function properly or is damaged in any way.

**⚠ WARNING**

- Never allow persons to ride in the cargo area of a vehicle. In the event of an accident, there is a much greater risk of injury for persons who are not riding in a seat with their seat belt securely fastened.
- Seat belts should always be adjusted so the lap portion of the belt is worn low across the pelvis, not across the waist. Shoulder straps should be worn on the outside shoulder only, and never under the arm. Seat belts should never be worn with the straps twisted and should be adjusted as tightly as is comfortable to provide the protection for which they have been designed. A slack belt will provide less protection than one which is snug.
- Make sure that each seat belt buckle is inserted into the proper buckle catch.
- Do not wear your seat belt over hard or breakable objects in your



**⚠ WARNING**

- ◀
- pockets or on your clothing. If an accident occurs, objects such as glasses, pens, etc. under the seat belt can cause injury.
  - Never use the same seat belt on more than one occupant and never attach a seat belt over an infant or child being held on an occupant's lap. Such seat belt use could cause serious injury in the event of an accident.
  - Pregnant women should use seat belts, although specific recommendations about restraint use should be made by the woman's medical advisor.
  - Periodically inspect seat belt assemblies for excessive wear and damage. Seat belts should be replaced if webbing becomes frayed, contaminated, or damaged in any way. It is essential to replace the entire seat belt assembly after it has been stressed in an impact, even if damage to the assembly is not obvious.
- 

**⚠ WARNING**

- ◀
- Infants and small children should never be transported unless they are properly restrained. Restraint systems for infants and small children can be purchased locally and should be used. Make sure that the system you purchase meets applicable safety standards. Read and follow all the directions provided by the manufacturer.
  - Avoid contamination of seat belt webbing by polishes, oils, chemicals, and particularly battery acid. Cleaning may safely be carried out using mild soap and water.
  - For children, if the shoulder belt irritates the neck or face, move the child closer to the center of the vehicle.

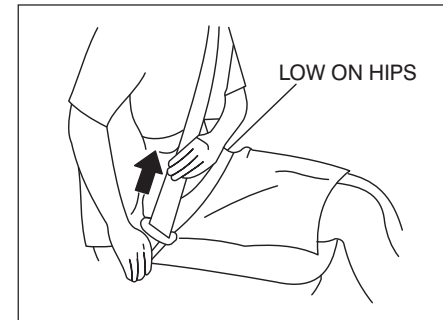

70F-01-024E

**To Adjust the Belt**

- **Automatic retracting type (if equipped)**  
Pull the shoulder portion of the belt upwards through the tongue plate.

The length of the diagonal shoulder strap adjusts itself to allow freedom of movement. The seat belt has an emergency locking retractor (ELR), which is designed to lock the seat belt only during a sudden stop or impact.

**⚠ WARNING**

No modifications or additions of any sort should be made to the seat belt or its operating mechanism.

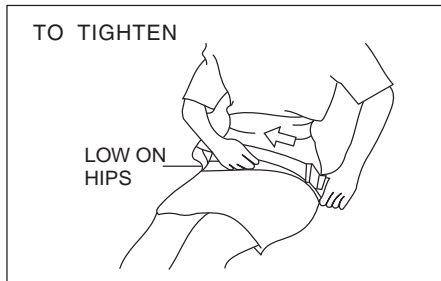

- **Lap belt (if equipped)** 60G-03-018E  
On this belt the adjuster is incorporated in the tongue unit.

To tighten the belt, pull the free end of the belt across alongside the lap strap until it is adjusted to a snug comfortable position.

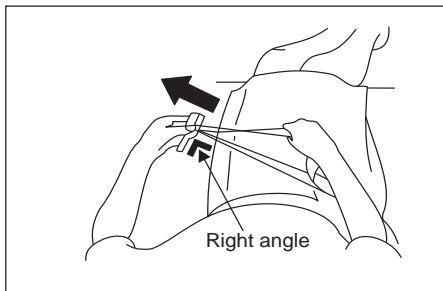

To lengthen, release the tongue from the buckle unit, pull the tongue (adjuster) in the direction of the arrow, at right angles to the belt. The tongue should then be refitted into the buckle unit and the belt tightened as previously described.

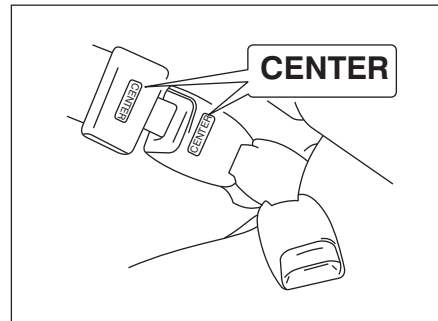

60G-03-029E

**NOTE:**

To identify the center seat belt buckle catch and tongue in the rear seat, "CENTER" is moulded on the buckle catch and tongue of the center lap belt. The buckle catches are designed so a buckle tongue can not be inserted into the wrong buckle catch.

## **STEERING COLUMN CONTROLS**

Ignition Switch .....	4-1
Lighting/Turn Signal Control Lever .....	4-2
Hazard Warning Switch .....	4-3
Windscreen Wiper and Washer Lever .....	4-3
Horn .....	4-4

IGNITION SWITCH

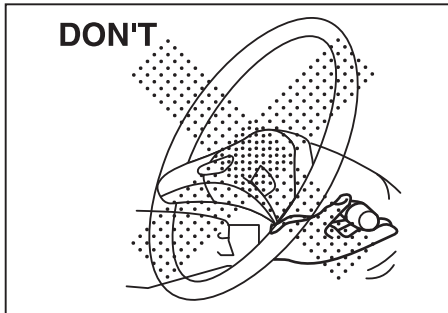

797-04-002E

**w WARNING**  
 To avoid possible injury, do not operate controls by reaching through the steering wheel.

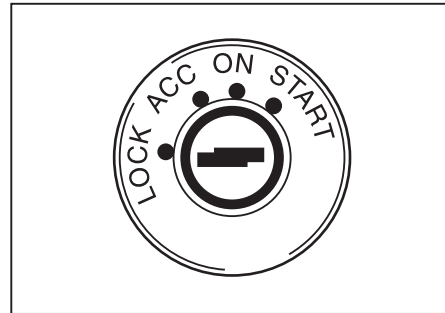

70F-02-002

The ignition switch has the following four positions:

**w WARNING**

- Do not use any locally made key.
- Should you require duplicate key, place your order with MARUTI SUZUKI dealer only.

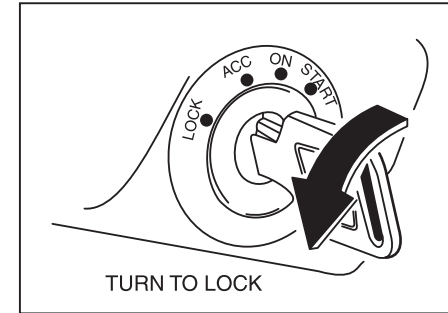

70F-02-003E

**LOCK**

This is the normal parking position. It is the only position in which the key can be removed.

The "LOCK" position locks the ignition, and prevents normal use of the steering wheel after the key is removed.

To release the steering lock, fully insert the key and turn it clockwise to one of the other positions. If you have trouble turning the key to unlock the steering, try turning the steering wheel slightly to the right or left while turning the key.



**ACC**

Accessories such as the radio can operate, but the engine is off.

**ON**

This is the normal operating position. All electrical systems are on.

**START**

This is the position for starting the engine using the starter motor. The key should be released from this position as soon as the engine starts.

**W WARNING**

- Never remove the ignition key while the vehicle is moving. The steering wheel will lock and you will not be able to steer the vehicle.
- Do not leave children alone in a parked vehicle. Unattended children could cause accidental movement of the vehicle, which could result in severe personal injury.
- Always remove the key when parked to prevent unintentional operation of the vehicle and to improve security.

**CAUTION**

- Do not use the starter motor for more than 15 seconds at a time. If the engine does not start; wait 15 seconds before trying again. If the engine does not start after several attempts, check the fuel and ignition systems or consult your MARUTI SUZUKI dealer.
- Do not leave the ignition switch in the "ON" position if the engine is not running as the battery will discharge.

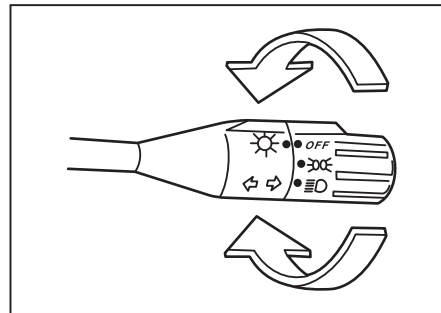
**LIGHTING/TURN SIGNAL CONTROL LEVER**

843-04-003

This control lever is located on the outboard side of the steering column. Operate the lever as described below.

**Lighting Operation**

To turn the lights on or off, twist the knob on the end of the lever. There are three positions: in the "OFF" position all lights are off; in the middle position the front parking lights, tail-lights, registration plate light, and instrument lights are on, but the headlights are off; in the third position the headlights come on in addition to the other lights.

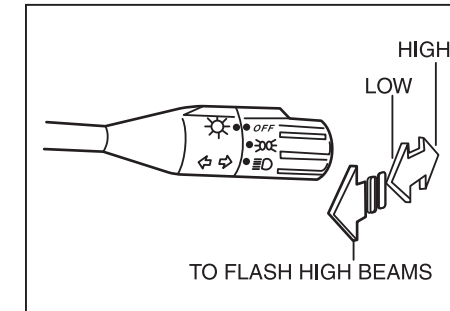

843-04-004E

With the headlights on, push the lever forward to switch to the high beams (main beams) or pull the lever toward you to switch to the low beams. When the high beams (main beams) are on, a light on the instrument panel will come on. To flash the high beams (main beams) pull the lever slightly towards you and release it.

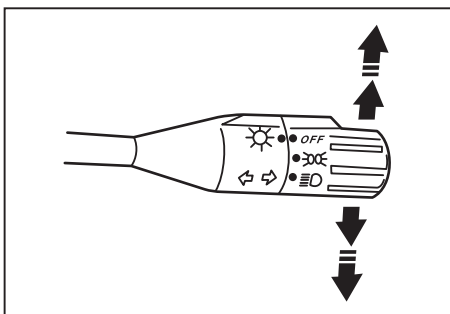

843-04-005

**Turn Signal Operation**

With the ignition switch in the “ON” position, move the lever clockwise until it clicks to signal a right turn or anticlockwise to signal a left turn. When the turn is completed, the signal will cancel and the lever will return to its normal position.

**HAZARD WARNING SWITCH**

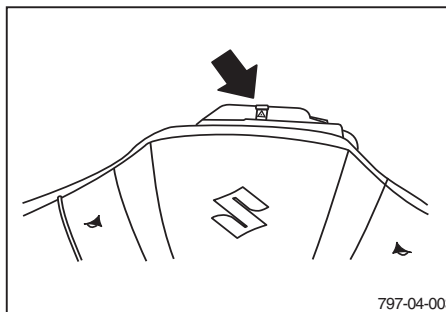

797-04-003

Pull up the hazard warning switch to activate the hazard warning lights. All four turn signal lights and both turn signal indicators will flash simultaneously. To turn off the lights, push down switch.

Use the hazard warning lights to warn other traffic during emergency parking or when your vehicle could otherwise become a traffic hazard.

**WINDSCREEN WIPER AND WASHER LEVER**

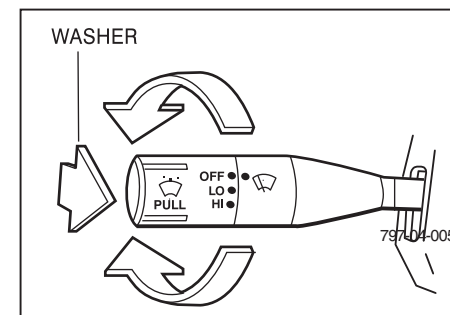

797-04-005E

**Windscreen Wipers**

To turn the windscreen wipers on, twist the knob on the end of the lever to one of the three operating positions. In the “LO” position, the wipers operate at a steady low speed. In the “HI” position, the wipers operate at a steady high speed. To turn off the wipers, move the lever back to the “OFF” position.

**Windscreen Washer**

To spray windscreen washer fluid, pull the lever toward you.

**w WARNING**

- Do not use radiator antifreeze in the windscreen washer reservoir. It can severely impair visibility when sprayed on the windscreen, and can also damage your vehicle's paint.

**CAUTION**

To help prevent damage to the windscreen wiper and washer system components, you should take the following precautions:

- Do not continue to hold in the lever when there is no windscreen washer fluid being sprayed or the washer motor can be damaged.
- Do not attempt to remove dirt from a dry windscreen with the wipers or you can damage the windscreen and the wiper blades. Always wet the windscreen with washer fluid before operating the wipers.
- Clear ice or packed snow from the wiper blades before using the wipers.
- Check the washer fluid level regularly. Check it often when the weather is bad.
- Only fill the washer fluid reservoir 3/4 full during cold weather to allow room for expansion if the temperature falls low enough to freeze the solution.

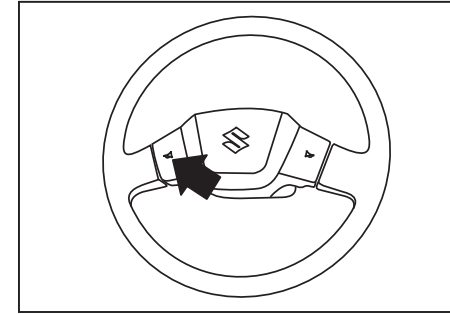
**HORN**

72F-04-006

With the ignition switch in "ON" position, press the horn button of the steering wheel to sound the horn.



## INSTRUMENT PANEL

Warning and Indicator Lights .....	5-3
Speedometer/Odometer .....	5-6
Fuel Gauge .....	5-6
Temperature Gauge .....	5-6
Cigarette Lighter (if equipped) .....	5-7
Glove Box .....	5-7
Headlight Leveling Switch (if equipped) .....	5-7
Demister System .....	5-9

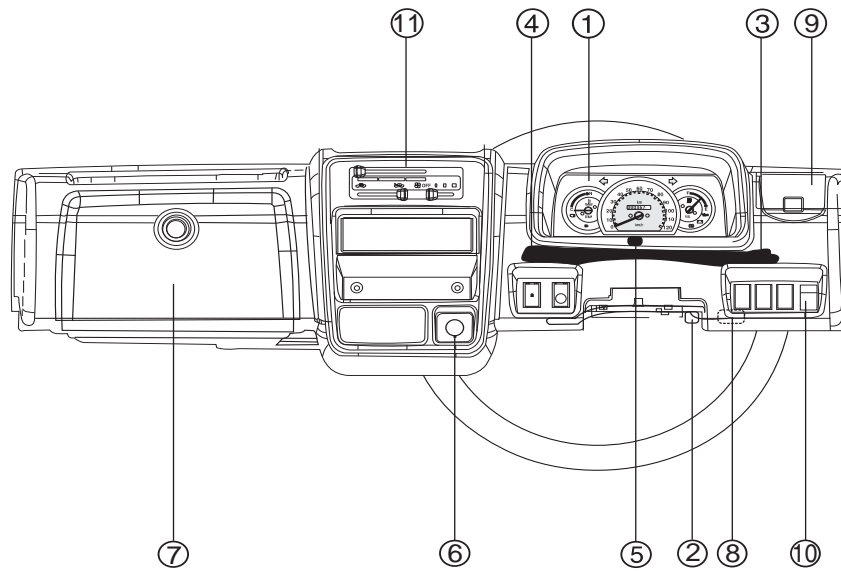

1. Instrument cluster
2. Ignition switch
3. Lighting switch/Turn signal and dimmer switch
4. Windscreen wiper and washer switch
5. Hazard warning switch
6. Cigarette lighter (if equipped)
7. Glove box
8. Fuse box
9. Brake fluid reservoir lid
10. Head Light Leveling Switch (if equipped)
11. Demister control Panel (if equipped)

Omni MPI

Omni MPI

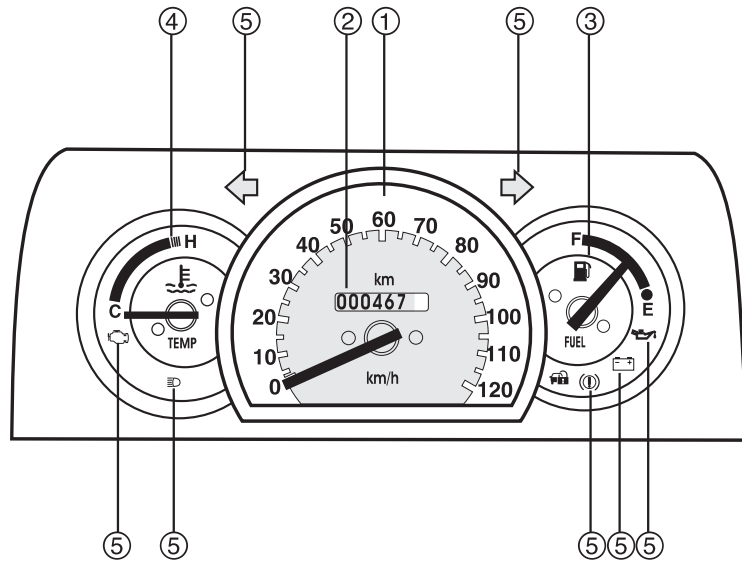

- ① Speedometer
- ② Odometer
- ③ Fuel gauge
- ④ Temperature gauge
- ⑤ Warning and indicator lights

797-05-009

WARNING AND INDICATOR LIGHTS



70F-07-029

**Brake fluid level warning light**

This light operates under two conditions: 1) when the ignition switch is turned to the "ON" position, or 2) when the fluid in the brake fluid reservoir falls below the specified level. The light should go out after starting the engine. If the light does not go off or comes on whilst you are driving, it may mean that there is something wrong with the vehicle's braking system. If this happens, you should:

- 1) Pull off the road and stop carefully.

**w WARNING**

Remember that stopping distance may be longer, you may have to push harder on the pedal, and the pedal may go down farther than normal.

- 2) Test the brakes by carefully starting and stopping at the side of the road.
  - 3) If you determine that it is safe, drive carefully at low speed to the nearest dealer for repairs.
- or
- 4) Have the vehicle towed to the nearest dealer for repairs.

**w WARNING**

If any of the following conditions occur, you should immediately ask your MARUTI SUZUKI dealer to inspect the brake system.

- If the brake fluid level warning light does not go out after the engine has been started.
- If the brake fluid level warning light does not come on when the ignition switch is turned to the "ON" position.
- If the brake fluid level warning light comes on at any time during vehicle operation.

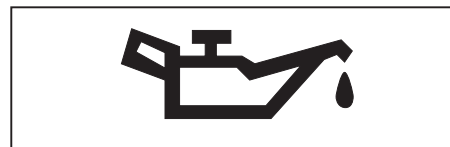

70F-03-007

**Oil Pressure Light**

This light comes on when the ignition switch is turned on, and goes out when the engine is started. The light will come on and remain on if there is insufficient oil pressure. If the light comes on when driving, pull off the road as soon as you can and stop the engine. Check the oil level and add oil if necessary (see pages 9-7 and 9-8). If there is enough oil, the lubrication system should be inspected by your MARUTI SUZUKI dealer before you drive the vehicle again.

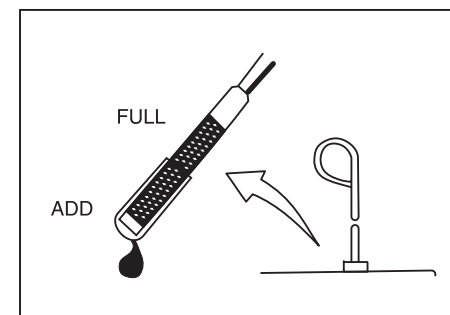

797-05-003



**CAUTION**

- If you operate the engine with this light on, severe engine damage can result.
- Do not rely on the Oil Pressure Light to indicate the need to add oil. Be sure to periodically check the engine oil level (see pages 9-7 and 9-8).



70F-03-009

**Charging Light**

This light comes on when the ignition switch is turned on, and goes out when the engine is started. The light will come on and remain on if there is something wrong with the battery charging system. If the light comes on when the engine is running, the charging system should be inspected immediately by your MARUTI SUZUKI dealer.

**CAUTION**

Do not continue driving long with the charging light ON as this will drain the battery 'dead'.



72F-05-027

**"Malfunction Indicator" Light**

Your vehicle has a computer-controlled emission control system. A "Malfunction Indicator" light is provided on the instrument panel to indicate when it is necessary to have the emission control system serviced. The "Malfunction Indicator" light comes on when the ignition switch is turned to "ON" and goes out when the engine is started. If the "Malfunction Indicator" light comes on when the engine is running, there is a problem with the emission control system. Take the vehicle to your MARUTI SUZUKI dealer to have the problem corrected.

**CAUTION**

Continuing to drive the vehicle when the "Malfunction Indicator" light is on can cause permanent damage to the vehicle's emission control system, and can affect fuel economy and driveability.



54G003

**Immobilizer System Light (if equipped)**

When the ignition switch is turned to the "ON" position, this light comes on to let you know the light is working. If this light blinks with the ignition switch turned to "ON", there may be something wrong with the immobilizer system. Contact your Maruti Suzuki dealer to have the system inspected.

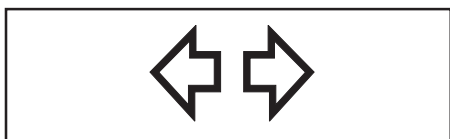

70F-03-011

**Turn Signal Indicators**

When you turn on the left or right turn signals, the corresponding green arrow on the instrument panel will flash along with the respective turn signal lights. When you turn on the hazard warning switch, both arrows will flash along with all of the turn signal lights.

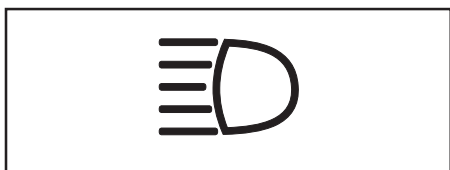

70F-03-012

**Main Beam (High Beam) Indicator Light**

This indicator comes on when headlight main beams (high beams) are turned on.

- 1 Speedometer

**SPEEDOMETER/ODOMETER**

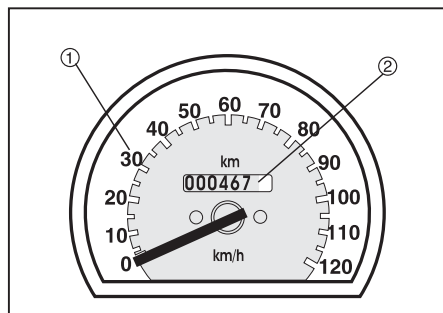

797-05-004

- 1 Speedometer
- 2 Odometer

The speedometer indicates vehicle speed in km/h. The odometer records the total distance the vehicle has been driven.

**CAUTION**

**Keep track of your odometer reading and check the maintenance schedule regularly for required services. Increased wear or damage to certain parts can result from failure to perform required services at the proper mileage intervals and your warranty rights may be affected.**

**FUEL GAUGE**

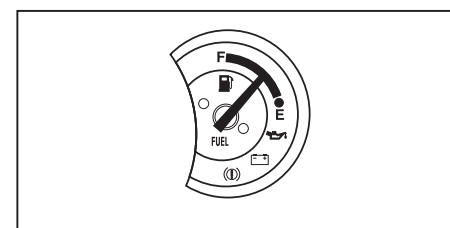

797-05-005

With ignition switch in ON position this gauge gives an approximate indication of the amount of fuel in the fuel tank. "F" stands for full and "E" stands for empty.

**TEMPERATURE GAUGE**

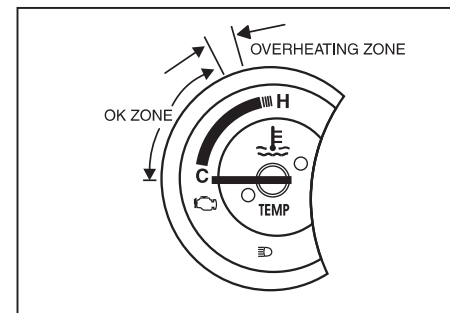

797-05-006

When the ignition switch is on, this gauge indicates the engine coolant temperature. Under normal driving conditions, the indicator should stay within the normal, acceptable temperature range between "H" and "C". If the indicator approaches "H", and maintains that reading, overheating is indicated. Follow the instructions for engine overheating in the EMERGENCY REMEDIES section.

**CAUTION**

Continuing to drive the vehicle when engine overheating is indicated, can result in severe engine damage.

**CIGARETTE LIGHTER (if equipped)**

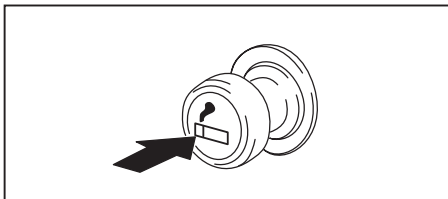

70F-03-024

To use the cigarette lighter, push it all the way into the receptacle and release it. It will automatically heat up and will pop out to its normal position when it is ready for use.

**GLOVE BOX**

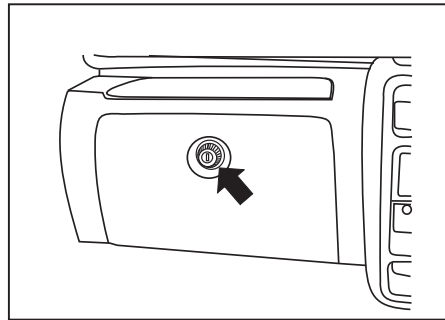

797-05-007

To open the glove box, pull the latch lever. To close it, push the lid until it latches securely.

**w WARNING**

Never drive with the glove box lid open. It could cause injury if an accident occurs.

**HEADLIGHT LEVELING SWITCH (if equipped)**

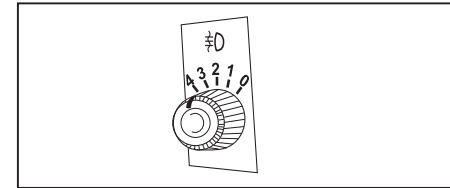

80G025

Level the headlight beam according to the load condition of your vehicle by turning this switch. The chart shows the appropriate switch position for different vehicle-load conditions.

**Switching Position for 5 Seater**

Vehicle Load Condition	Switch Position
Driver only	0
Driver + One passenger at front seat	0
Driver + One passenger at front seat + All Three passenger at the rear	1
Dummy	2, 3, 4

**Switching Position for 8 Seater / Ambulance**

Vehicle Load Condition	Switch Position
Driver only	0
Driver + One passenger at front seat	0
All passengers	1
All passengers + Evenly distributed load in Luggage boot	2
Driver + Evenly distributed load in Luggage boot	3
Dummy	4

**Switching Position for Cargo**

Vehicle Load Condition	Switch Position
Driver only	0
Driver + One passenger at front seat	0
Driver + One Passenger at front seat + Evenly distributed load on Luggage boot	1
Dummy	2, 3, 4

Omni MPI

**DEMISTER SYSTEM**

The demister system Provides windshield demisting (a)

a. Windscreen demister

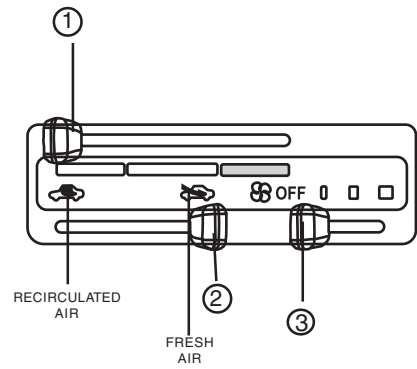
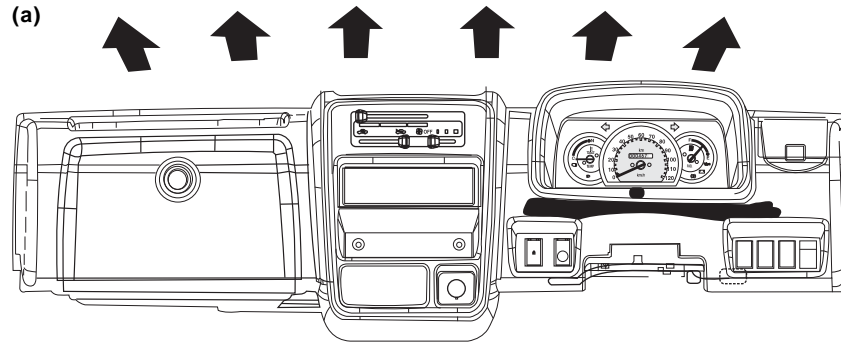

**Description of Controls**

**Temperature Control Lever** (1) This lever is used to control the temperature of the air that comes out of the demister nozzle.

**Air Intake Lever** (2) This lever is used to select between circulating outside air (FRESH AIR ) or recirculating inside air (RECIRCULATED AIR).

**Fan switch** (3) This switch is used to turn on the fan and to select. There are four positions: OFF, LOW, MEDIUM and HIGH

**SYSTEM OPERATING INSTRUCTIONS****Demisting**

Move the air intake lever to "FRESH AIR", the temperature control lever to the desired temperature control position, and the fan switch to "HIGH". Moving the temperature control lever to a higher temperature position increases defrosting efficiency. When the windshield has become clear, move the fan switch to the desired fan speed position.

## OTHER CONTROLS AND EQUIPMENT

Parking Brake Lever .....	6-1
Pedals .....	6-1
Gear Lever .....	6-2
Fuel Filler Cap .....	6-2
Front Seats Removal .....	6-3
Luggage Compartment .....	6-4
Sun Visor .....	6-4
Ventilator .....	6-4
Interior Light Switches .....	6-5
Assist Grips .....	6-5
Tyre Changing Tools .....	6-5
High Mount Stop Lamp (if equipped) .....	6-6

**PARKING BRAKE LEVER**

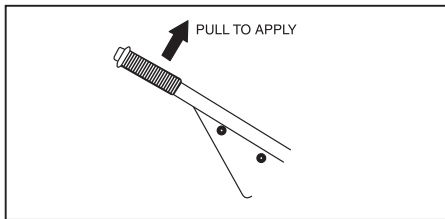

797-06-001E

The parking brake lever is located between the seats. To apply the parking brake, hold the brake pedal down and pull the parking brake lever all the way up. To release the parking brake, hold the brake pedal down, pull up slightly on the parking brake lever, push the button on the end of the lever with your thumb, and lower the lever to its original position.

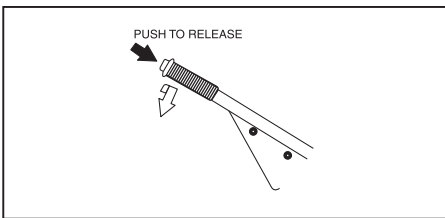

797-06-002F

**W WARNING**

- Never drive your vehicle with the parking brake on: rear brake effectiveness can be reduced from over heating, brake life may be shortened, or permanent brake damage may result.
- If the parking brake does not hold the vehicle securely or does not fully release, have your vehicle inspected immediately by an authorized MARUTI SUZUKI dealer.

**W WARNING**

Always apply the parking brake fully before leaving your vehicle or it may move, causing injury or damage. When parking, make sure the gear shift lever is left in first gear or reverse. Remember, even though the transmission is in gear, you must always apply the parking brake fully.

**PEDALS**

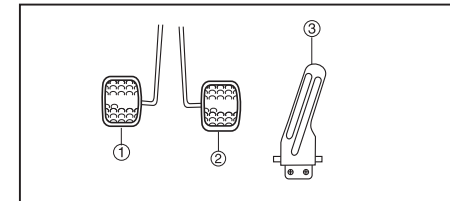

797-06-003

**Clutch Pedal**

The clutch pedal is used to disengage the drive to the wheels when starting the engine, stopping, or shifting the transmission lever. Depressing the pedal disengages the clutch.

①

**CAUTION**

Do not drive with your foot resting on the clutch pedal. It could result in excessive clutch wear, clutch damage, or unexpected loss of engine braking.

**Brake Pedal**

Your MARUTI SUZUKI vehicle is equipped with front and rear drum brakes. Depressing the brake pedal applies both sets of brakes. You may hear occasional brake squeal when you apply the brakes. This is a nor-



## GEAR LEVER

mal condition caused by environmental factors such as cold, wet, snow, etc.

**W WARNING**

If brake squeal is excessive and occurs each time the brakes are applied, you should have the brakes checked by your MARUTI SUZUKI dealer.

**W WARNING**

Do not "ride" the brakes by applying them continuously or resting your foot on the pedal. This will result in overheating of the brakes which could cause unpredictable braking action, longer stopping distances, or permanent brake damage.

**Accelerator Pedal ③**

This pedal controls the speed of the engine. Depressing the accelerator pedal increases power output and speed.

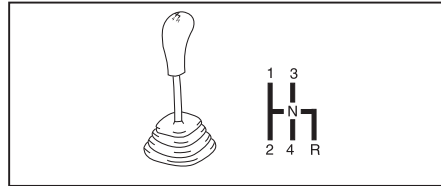

797-06-004

The gear change pattern is shown in the illustration. For details on how to use the transmission, refer to USING THE TRANSMISSION in the OPERATING YOUR VEHICLE section (See page 7-2).

## FUEL FILLER CAP

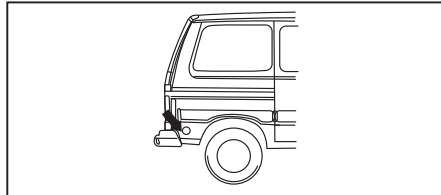

797-06-006

The fuel filler cap is located on the right rear side of the vehicle. To lock the fuel filler cap, turn the key clockwise. To unlock, turn the key anticlockwise.

**W WARNING**

Remove the fuel filler cap slowly. The fuel may be under pressure and may spray out, causing injury.

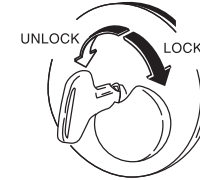

797-06-007

**W WARNING**

Petrol is extremely flammable. Do not smoke when refuelling, and make sure there are no open flames or sparks in the area.

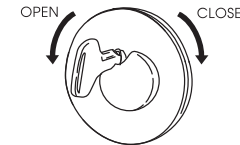

797-06-008E

- To remove - turn the cap counter-clockwise. Turn the cap slowly to allow any residual pressure to escape.
- To install - turn the cap clockwise.

**NOTE:**

The key is removable from cap in lock condition only

**CAUTION**

If you need to replace the fuel cap, use only a cap specified for your model. Using an improper fuel cap can cause a serious malfunction of the fuel system. You can get the correct replacement cap from your MARUTI SUZUKI dealer.

**FRONT SEATS REMOVAL**

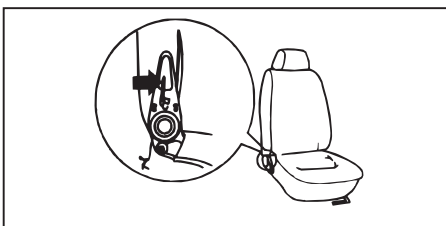

797-03-008

The seats are latched to the seat frame. To remove the seat use the following procedure.

1. Fold the seat forward by pushing the lever on the outboard side of the seat.
2. Release the seat latch and move the seat forward to remove.

To install the seat, insert the two projections on the back of the seat into the holes and latch the seat. Move the seatback to the original position to lock the seatback in place.

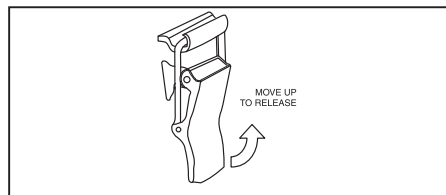

797-06-009E

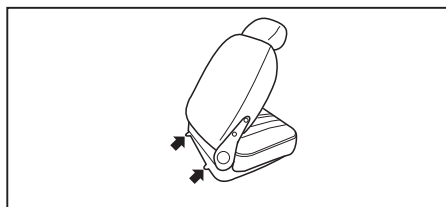

797-06-010

**LUGGAGE COMPARTMENT**

**WARNING**

Luggage or other cargo should be stowed in the luggage compartment whenever possible. If you need to carry cargo in the passenger compartment, be sure to secure the cargo or it may be thrown about, causing injury. Never pile cargo higher than the seatbacks.

**SUN VISOR**

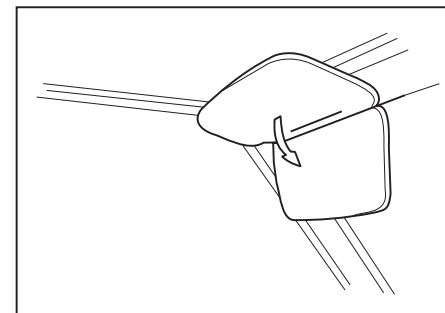

797-06-011

The sun visors can be pulled down to block glare coming through the wind screen.

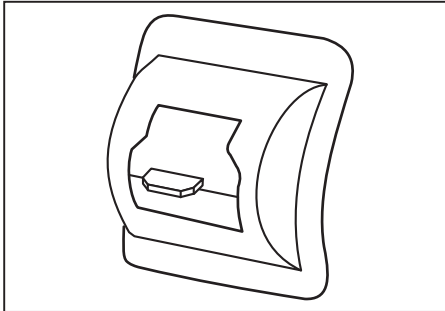
**VENTILATOR (if equipped)**

797-06-012

Two ventilators, one each on left and right side, are provided. Fresh air will flow through the vehicle when it is moving. Air flow can be regulated by changing the opening of the ventilator outlet grill.

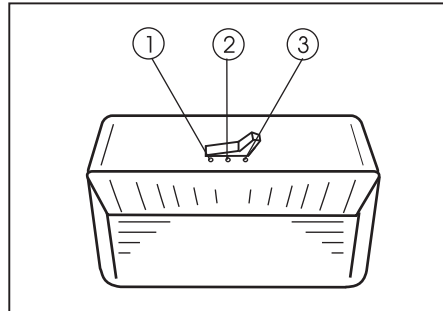
**INTERIOR LIGHT SWITCHES**

797-06-013

**Front/Center Interior Light**

These light switches have three positions which function as described below:

- ① The light comes on and stays on regardless of whether the door is open or closed.
- ② The light comes on when the door is opened.
- ③ The light remains off even when the door is opened.

**NOTE:**

*Only front doors are involved in lighting operation of interior light.*

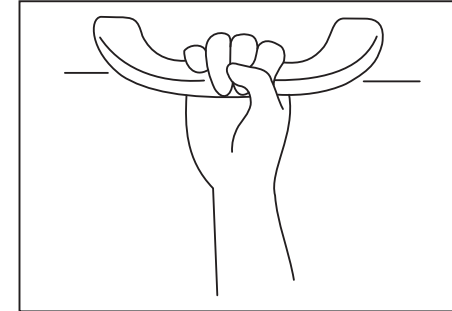
**ASSIST GRIPS**

70F-04-015

Assist grips are provided for passenger convenience.

**w WARNING**

**Do not hang items on the assist grips. They could obstruct the driver's view, resulting in an accident, or could be thrown about in an accident or abrupt manoeuvre, causing injury.**

**TYRE CHANGING TOOLS**

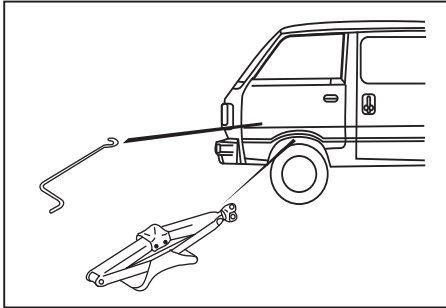

797-06-015

Jack Handle is stowed near the front left seat. Jack is stowed under the front left seat and can be taken out after removing the seat.

To remove the jack, turn its shaft counter-clockwise and pull the jack out of the storage bracket. To stow the jack, place it in the storage bracket and turn the shaft clockwise until the jack is securely held in place.

**W WARNING**

The jack should be used only to change wheels. It is important to read the jacking instructions in the EMERGENCY SERVICE section of this manual before attempting to use the jack.

**W WARNING**

After using the jack, jack handle, and wheel wrench, be sure to stow them securely or they can cause injury if an accident occurs.

**HIGH MOUNT STOP LAMP (if equipped)**

**EXAMPLE**

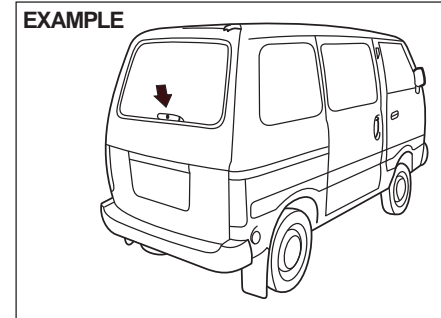

High mount stop lamp is provided with your vehicle and is fitted on back door. The stop lamp will glow as when the brake pedal will be depressed.

To change the bulb of the stop lamp, remove the clips at both sides of the cover, by pressing the inner pin inside so that the clip gets loose and remove the bulb on turning it anticlockwise

The rating of bulb is 16W/12V. There are one bulb in high mount stop lamp.

## OPERATING YOUR VEHICLE

Exhaust Gas Warning .....	7-1
Daily Inspection Checklist .....	7-1
Starting the Engine .....	7-2
Using the Transmission .....	7-2
Braking .....	7-3
Running-in .....	7-4
Catalytic Converter .....	7-4
Improving Fuel Economy .....	7-5
Trailer Towing .....	7-5

## EXHAUST GAS WARNING

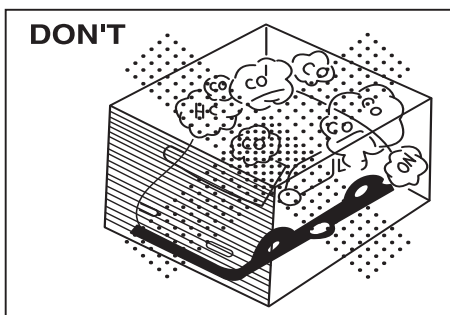

70F-05-001E

W **WARNING**

Avoid breathing exhaust gases. Exhaust gases contain carbon monoxide, a potentially lethal gas that is colourless and odourless. Since carbon monoxide is difficult to detect by itself, be sure to take the following precautions to help prevent carbon monoxide from entering your vehicle.

- Do not leave the engine running in garages or other confined areas.
- Do not park with the engine running for a long period of time, even in an open area.

W **WARNING**



- Avoid operating the vehicle with the backdoor open.
- Keep the exhaust tailpipe area clear of snow and other material to help reduce the buildup of exhaust gases under the vehicle. This is particularly important when parked in blizzard conditions.
- Have the exhaust system inspected periodically for damage and leaks. Any damage or leaks should be repaired immediately.

## DAILY INSPECTION CHECKLIST

**Before driving:**

- 1) Make sure that windows, mirrors, lights, and reflectors are clean and unobstructed.
- 2) Check the tyres.
- 3) Look for fluid and oil leaks.
- 4) Adjust the seat/head restraint.
- 5) Check the brake pedal.
- 6) Adjust the mirrors.
- 7) Make sure that you and passengers have properly fastened your seat belts.
- 8) Make sure that all warning lights come on as the key is turned to the "ON" position.
- 9) Check all gauges.
- 10) Make sure that the brake fluid level warning light is off after starting the engine.

Once a week, or each time you fill your fuel tank, perform the following checks:

- 1) Engine oil level.
- 2) Coolant level.
- 3) Brake fluid level.
- 4) Windscreen washer fluid level.
- 5) Battery solution level.

## STARTING THE ENGINE

### Before starting the engine:

- 1) Make sure the parking brake is applied fully.
- 2) Shift into "N" (neutral) and depress the clutch pedal all the way to the floor. Hold it while starting the engine.

### **w** WARNING

**Make sure that the parking brake is applied fully and the transmission is in Neutral before attempting to start the engine.**

### CAUTION

- **Stop turning the starter immediately after the engine has started or the starter system can be damaged.**
- **Do not crank the engine for more than 15 seconds at a time. If the engine doesn't start on the first try, wait about 15 seconds before trying again.**

### Starting a Cold Engine

Engine which is started after 6 hours should be treated as cold engine.

#### For Electronic fuel injection models

- With your foot off the accelerator pedal, crank the engine by turning the ignition key to "START". Release the key when the engine starts.
- If the engine does not start after 15 seconds of cranking, wait about 15 seconds, then press down the accelerator pedal to 1/3 of its travel and try cranking the engine again. Release the key and accelerator pedal when the engine starts.
- If the engine still does not start, try holding the accelerator pedal all the way to the floor while cranking. This should clear the engine if it is flooded.

### Starting a Warm Engine

**For Electronic fuel injection models :** Use the same procedure as for "Starting a cold Engine."

## USING THE TRANSMISSION

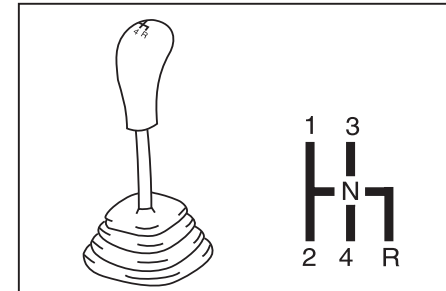

797-06-004

### Starting off

To start off, depress and maintain pressure upon the clutch pedal and change into 1st gear. After releasing the parking brake, gradually release the clutch. When you hear a change in the engine's sound (speed), gently apply pressure to the accelerator to keep the engine sound (speed) constant whilst continuing to gradually release the clutch.

### Gear changing

All forward gears are synchronized, which provides for quiet, easy changing. Always depress the clutch pedal fully before changing gears. To help gearshift, the following chart shows the recommended speed range in each gear.

	Min Speed	Max. Speed
First	–	30 km/h
Second	10 km/h	50 km/h
Third	20 km/h	90 km/h
Fourth	30 km/h	Top Speed

**w WARNING**

- Reduce your speed and change down to a lower gear before going down a long or steep hill. A lower gear will allow the engine to provide braking. Avoid riding the brakes or they may overheat, resulting in brake failure.
- When driving on slippery roads, be sure to slow down before changing down. Excessive and or sudden changes in engine speed may cause loss of traction, which could cause you to lose control.
- Make sure that the vehicle is completely stationary before you change into reverse.

**CAUTION**

- To help avoid clutch damage, do not use the clutch pedal as a footrest while driving or use the clutch to keep the vehicle stationary on a hill. Depress the clutch fully when changing gear.
- When changing gears or starting off, do not race the engine. Racing the engine can shorten engine life and prevent smooth operation.

**BRAKING**

The distance needed to bring any vehicle to a halt increases with the speed of the vehicle. The braking distance needed, for example, at 60 km/h will be approximately 4 times greater than the braking distance needed at 20 km/h. Start to brake the vehicle when there is plenty of distance between your vehicle and the stopping point, and slow down gradually.

**w WARNING**

If water gets into the brake drums, brake performance may become poor and unpredictable. After driving through water or washing the underside of the vehicle, test the brakes while driving at a slow speed to see if they have maintained their normal effectiveness. If the brakes are less effective than normal, dry them by repeatedly applying the brakes while driving slowly until the brakes have regained their normal effectiveness.



## RUNNING-IN

**CAUTION**

The future performance and reliability of the engine depends on the care and restraint exercised during its early life. It is especially important to observe the following precautions during the initial 1000 km of vehicle operation.

- After starting, do not race the engine. Warm it up gradually.
- Avoid prolonged vehicle operation at a constant speed. Moving parts will bed in better if you vary your speed.
- Do not exceed 90 km/h.
- Start off from a stop slowly. Avoid full throttle starts.
- If possible, avoid hard braking, especially during the first 300 km of driving.
- Do not drive slowly with the transmission in a high gear.
- Drive the vehicle at moderate engine speeds.

## CATALYTIC CONVERTER

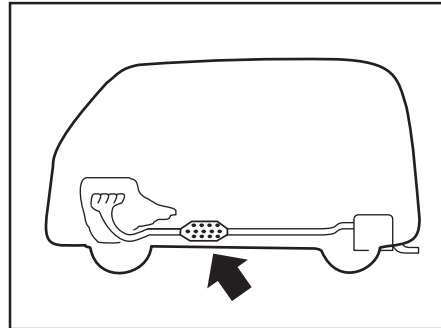

797-07-001

The purpose of the catalytic converter installed on your vehicle is to convert exhaust pollutants to harmless water vapour, carbon dioxide, and nitrogen. Use of leaded fuel in vehicles equipped with catalytic converters is prohibited, because lead deactivates the pollutant-reducing components of the catalyst system.

It is very important to keep the engine properly tuned. Engine misfiring, which can result from an improperly tuned engine, may cause overheating of the catalyst. This may result in permanent heat damage to the catalyst and other vehicle components.

**CAUTION**

To minimize the possibility of catalyst or other vehicle damage:

- Maintain the engine in the proper operating condition.
- In the event of an engine malfunction, particularly one involving engine misfire or other apparent loss of performance, have the vehicle serviced promptly.
- Do not turn off the engine or interrupt the ignition when the transmission is in gear and the vehicle is in motion.
- Do not try to start the engine by pushing or towing the vehicle, or coasting down a hill.
- Do not idle the engine with any spark plug wires disconnected or removed, such as during diagnostic testing.
- Do not idle the vehicle for prolonged periods if idling seems rough or there are other malfunctions.
- Do not allow the fuel tank to get near the empty level.

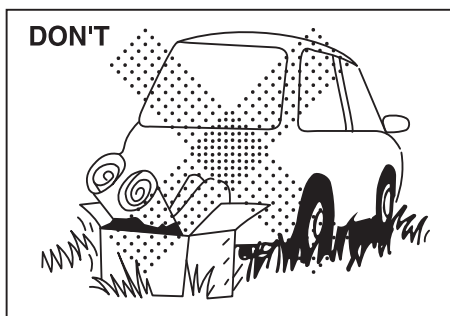

70F-05-006E

**w WARNING**

**Be careful where you park and drive; the catalytic converter and other exhaust components can get very hot. As with any vehicle, do not park or operate this vehicle in areas where combustible materials such as dry grass or leaves can come in contact with a hot exhaust system.**

### IMPROVING FUEL ECONOMY

The following instructions will help you improve fuel economy.

**Avoid excessive idling:**

If you are to wait for more than a minute while you are parked, stop the engine and start it again later. When warming up a cold engine, allow the engine to idle until the temperature gauge pointer comes up to the "C" position. In this position, the engine is sufficiently warm for starting off.

**Avoid "fast" starts:**

Fast starts away from lights or stop signs will consume fuel unnecessarily and shorten engine life. Start off slowly.

**Avoid unnecessary stops:**

Avoid unnecessary deceleration and stopping. Try to maintain a slow, steady speed whenever possible. Slowing down and then accelerating again uses more fuel.

**Keep a steady cruising speed:**

Keep as constant a speed as road and traffic conditions will permit.

**Keep the air cleaner clean:**

A dirty air cleaner will cause the carburation system to supply too much fuel to the engine for the amount of air being supplied. The result is waste of fuel due to incomplete combustion.

**Keep weight to a minimum:**

The heavier the load, the more fuel the vehicle consumes. Take out any luggage or cargo when it is not necessary.

**Keep tyre pressures correct:**

Under-inflation of the tyres can waste fuel due to increased running resistance of the tyres. Keep your tyres inflated to the correct pressure shown on the label on the driver's side door or door lock pillar.

### TRAILER TOWING

Your MARUTI was originally designed to carry people and a normal amount of cargo, not to tow a trailer. Maruti Suzuki does not recommend you use your vehicle to tow a trailer. Towing a trailer can adversely affect handling, durability, and fuel economy.

## DRIVING TIPS AND SAFE DRIVING

High Speed Driving .....	8-1
Driving on Hills .....	8-1
Driving on Slippery Roads .....	8-1
Driving on Wet Roads .....	8-2
Do's and Don'ts for Safe Driving .....	8-3

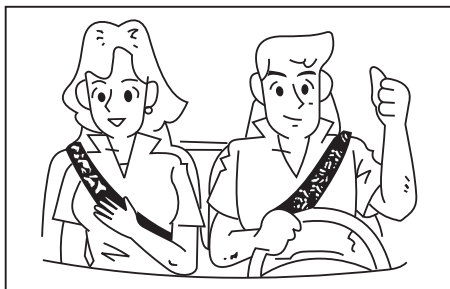

70F-06-001

**w WARNING**

- **Wear Your Seat Belts at All Times.** The driver and passengers should be properly restrained at all times, using the seatbelts provided. Refer to the “SEATBELTS” section for instructions on proper use of the seat belts.
- **Never drive while under the influence of alcohol or other drugs.** Alcohol and drugs can seriously impair your ability to drive safely, greatly increasing the risk of injury to yourself and others. You should also avoid driving when you are tired, sick, irritated, or under stress.

**HIGH-SPEED DRIVING**

When driving at a high-speed, pay attention to the following:

- Stopping distance progressively increases with vehicle speed. Apply the brakes far enough ahead of the stopping point to allow for the extra stopping distance.
- On rainy days, “Aquaplaning” can occur. “Aquaplaning” is the loss of direct contact between the road surface and the vehicle’s tyres due to a water film forming between them. Steering or braking the vehicle while “Aquaplaning” can be very difficult, and loss of control can occur. Keep speed down when the road surface is wet.
- At high speeds, the vehicle may be affected by side winds. Therefore, reduce speed and be prepared for unexpected buffeting, which can occur at the exits of tunnels, when passing by a cut of a hill, or when being overtaken by large vehicles, etc.

**DRIVING ON HILLS**

- When climbing steep hills, the vehicle may begin to slow down and show a lack of power. If this happens, you should change to a lower gear so that the engine will again be operating in its normal power range.

Change rapidly to prevent the car from losing momentum.

- When driving down a hill, the engine should be used for braking by shifting to next lower gear.

**w WARNING**

**Try not to hold the brake pedal down too long or too often while going down a steep or long hill. This could cause the brakes to overheat, resulting in reduced braking efficiency. Failure to take this precaution could result in loss of vehicle control.**

**CAUTION**

**When descending a down hill, NEVER turn the ignition key to the “OFF” position. Emission control system damage may result.**

**DRIVING ON SLIPPERY ROADS**

Under wet road conditions you should drive at a lower speed than on dry roads due to possible slippage of tyres during braking. When driving on icy, snowcovered, or muddy roads, reduce your speed and avoid sudden acceleration, abrupt braking, or sharp steering movements.

### Snow Chains

If you must use snow chains to increase tyre traction, observe the following precautions:

- Choose a safe place away from traffic to install the chains.
- When installing the chains carefully follow the manufacturer's instructions.
- Install the chains on the rear tyres.
- With the chains on, drive only at slow and moderate speeds.

#### • If Your Vehicle Gets Stuck

If your vehicle gets stuck in snow, mud, or sand, follow the directions below:

- 1) Change back and forth between first gear and reverse. This will create a rocking motion which may give you enough momentum to free the vehicle. Press gently on the accelerator to keep wheel spin to a minimum. Remove your foot from the accelerator while changing gear.

Do not race the engine. Excessive wheel spin will cause the tyres to dig deeper, making it more difficult to free the vehicle.

- 2) If your vehicle remains stuck after a few minutes of rocking, get another vehicle to pull you out.

#### ⚠ WARNING

**Do not allow anyone to stand near the vehicle when you are rocking it, and do not spin the wheels faster than an indicated 40 km/h on the speedometer. Personal injury and/or vehicle damage may result from spinning the wheels too fast.**

#### CAUTION

**Do not continue rocking the vehicle for more than a few minutes. Prolonged rocking can cause engine overheating or transmission damage.**

#### DRIVING ON WET ROADS

#### CAUTION

- When driving on wet roads, avoid driving through large amount of standing water on the road. Large amount of water entering the engine compartment may cause damage to the engine and or electrical components.
- If stuck in deep water, do not start till water level drops.
- Water is incompressible substance, water inside engine is harmful to the engine."

#### ⚠ WARNING

- Make sure your tyres are in good condition and always maintain the specified tyre pressure. Refer to "TYRES" in the "INSPECTION AND MAINTENANCE" section for details.
- Do not use tyres other than those specified by MARUTI SUZUKI. Never use different sizes or types of tyres on the front and rear wheels. For information regarding the specified tyres, refer to the "SPECIFICATIONS" section.
- Never use oversized tyres or special shock absorbers and springs to raise (jack up) your vehicle. This will change the handling characteristics.
- After driving through water, test the brakes while driving at a slow speed to see if they have maintained their normal effectiveness. If the brakes are less effective than normal, dry them by repeatedly applying the brakes while driving slowly until the brakes have regained their normal effectiveness.

**DRIVING TIPS AND SAFE DRIVING**

797-74E-I

**DO'S AND DON'TS FOR SAFE DRIVING**

Exercise care in handling your vehicle. Be conscious of not only your own safety but also the safety of others on the road, and thus enjoy the best and most comfortable driving experience.

This section contains basic rules for safe driving. Read it carefully for good understanding of the content so that you can enjoy safe and pleasant driving in your Maruti Suzuki vehicle.

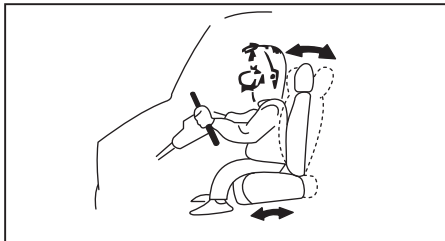

72F-08-001

**Starting**

1. Adjust the driver's seat for the proper driving posture.
2. Adjust the rear view mirror so as to obtain the best possible rear view.
3. Before moving off, look forward and back to confirm safety.

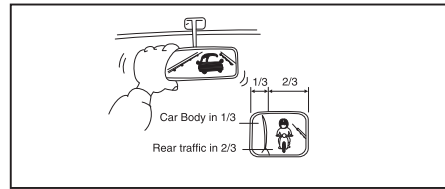

72F-08-002

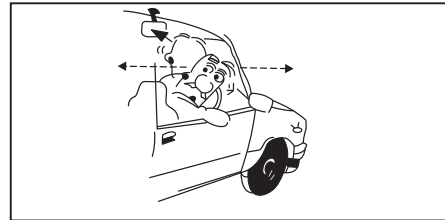

72F-08-003



72F-08-004

4. Don't start quickly, for it is dangerous and wastes fuel.

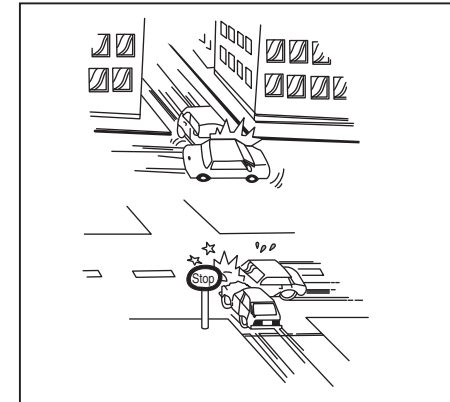

72F-08-005

**General driving**

1. Be sure to stop before the stop light and stop sign. When moving into the interchanges or signs, drive slowly to confirm safety.

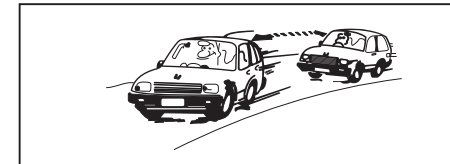

72F-08-006

2. Always follow other vehicles at a safe distance in order to prevent a rear-end collision, should the vehicle ahead make a sudden stop.

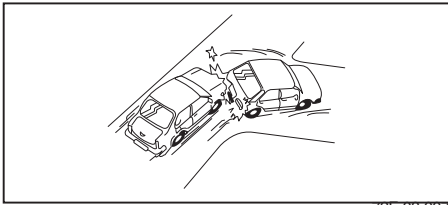

72F-08-007

3. Turn ON the turn signal at least 30 meters before making a turn or changing the lane so as not to be hit from behind.

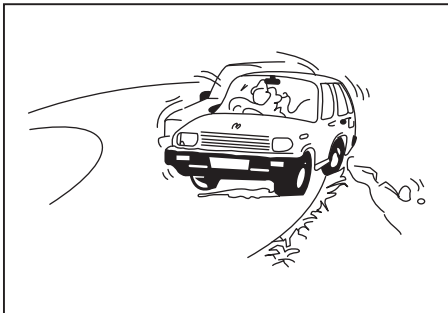

72F-08-008

4. Before entering a corner, decelerate to a safe speed. Don't apply brakes during cornering, or a cornering skid may occur.
5. When overtaking other vehicle, watch out for the oncoming vehicle and carefully confirm the safety.
6. Don't attempt zigzag driving which will hinder your control over the vehicle and cause an accident.

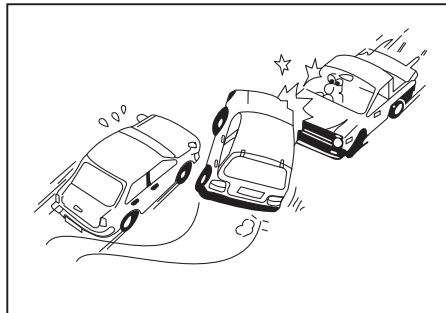

72F-08-009

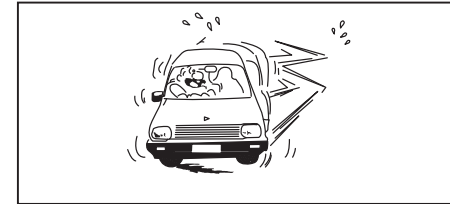

72F-08-010

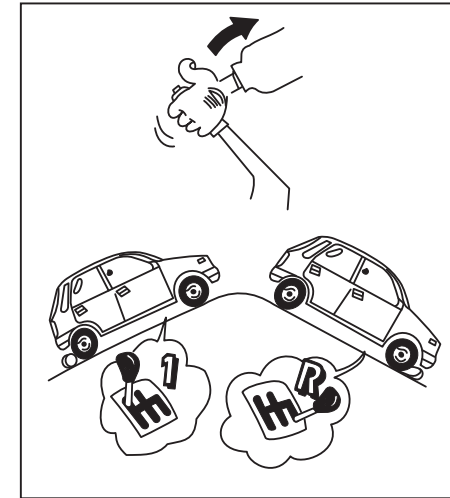

72F-08-011

sudden stop.

**Braking**

1. Use the parking brake when parking your vehicle and shift the gear shift lever into the first gear or reverse gear position for the sake of safety.



72F-08-012

2. Don't use handbraking unless unavoidable. It causes the vehicle to skid and a rearend collision occur. It is especially dangerous when the tyres are worn, for they allow a larger skid.

Use foot brake in three stages

- (1) Warn the vehicle behind you.
- (2) Gradually apply the brake.
- (3) Bring the vehicle to a halt.



72F-08-013

3. When driving on a downhill, try not to apply the brake but use the engine brake effectively. Overuse of the footbrake may result in total brake failure.

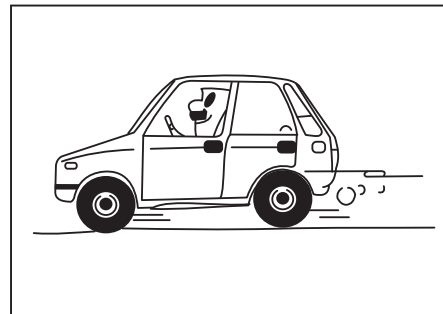

72F-08-014

4. Avoid reckless high speed driving and try to drive at a safe speed suitable for the road conditions while maintaining a constant speed.

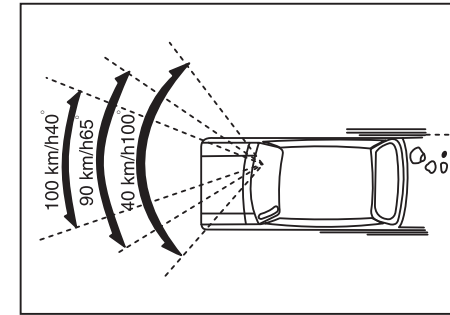

72F-08-015

5. The higher the speed, the narrower the driver's visual range becomes. In such a state, it is difficult to anticipate any hazard and the driver feels much fatigued.
6. Never do sharp handling during high speed driving. You will lose your control over your vehicle.
7. When overtaking or changing the lane while driving at a high speed, keep an ample vehicle-to-vehicle distance.





72F-08-016

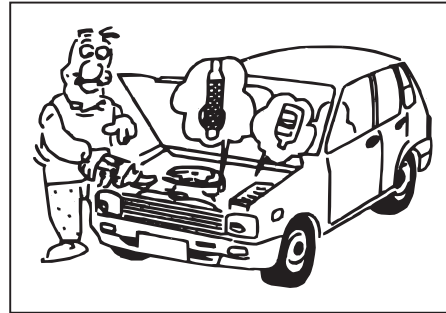

72F-08-018

**Long distance driving**

1. Be sure to perform safety checks before starting a trip.

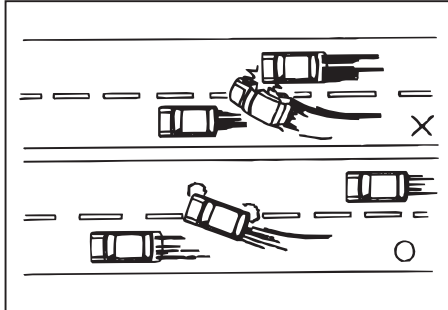

72F-08-017



72F-08-019

2. Take rest at certain intervals to prevent an accident which may occur when you are sleepy or tired.



72F-08-020

**Night time driving**

1. Drive more slowly at night than in the daytime, for the visual range is restricted at night.

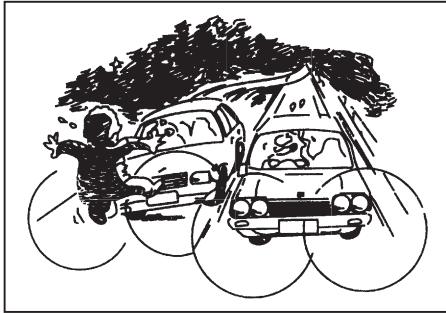

72F-08-021

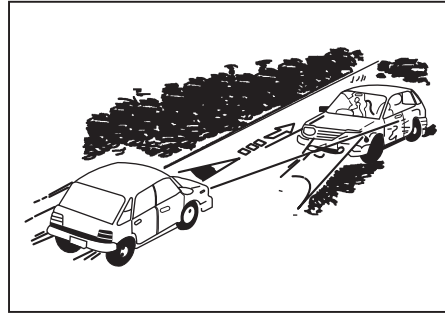

72F-08-022

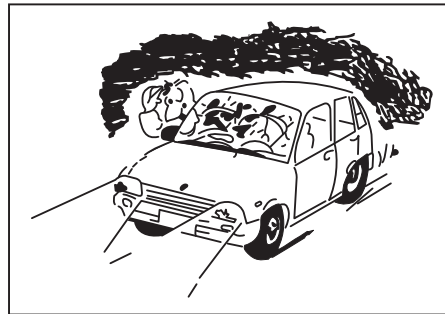

72F-08-023

2. Don't overtake other vehicles at night. Darkness bothers your sense of speed and hinders your judgement on the vehicle-to-vehicle distance.
3. Don't use the high headlight beam unless its use is inevitable. Its dazzle may blitz the driver of the oncoming car, thus causing an accident.
4. Always keep the window glasses clean. Don't operate the windshield wiper when the windshield glass is dry or the wiper blade and glass may get damaged.

**MARGIN FOR SAFETY**

It is important to allow yourself a margin for safety during driving so that you can cope with erroneous or unexpected driving of other drivers. For that, observe the following.

- Drive at a safe speed.
- Maintain a sufficient distance between your vehicle and the vehicle ahead. Don't force yourself to overtake other vehicles.
- Don't make quick start, hard steering or sudden stops.
- Allow an ample time in the driving schedule.
- Observe traffic rules and regulations.

**CONCLUSION**

A perfect driver does not exist. The endeavour of every motorist should be to strive for perfection. Safety consciousness not only ensures your safety and the safety of other road users, it also helps reduce the wear and tear on your vehicle, prolongs its life, gives more mileage and ensures a comfortable driving experience.

**Follow the do's and don'ts listed, and driving will never be the same again.**

## INSPECTION AND MAINTENANCE

Tool Kit .....	9-2
Periodic Maintenance Schedule .....	9-2
Water Pump Belt .....	9-6
Engine Oil and Filter .....	9-7
Gear Oil .....	9-10
Engine Coolant .....	9-11
Windscreen Washer Fluid .....	9-12
Air Cleaner .....	9-12
Spark Plugs .....	9-13
Brakes .....	9-14
Steering .....	9-16
Clutch Pedal .....	9-16
Tyres .....	9-17
Battery .....	9-20
Fuses .....	9-21
Bulb Replacement .....	9-22
Wiper Blades .....	9-25

**W WARNING**

You should take extreme care when working on your vehicle to prevent accidental injury. Here are a few precautions that you should be especially careful to observe:

- Do not leave the engine running in garages or other confined areas.
- When the engine is running, keep hands, clothing, tools, and other objects away from the fan and water pump belt.
- When it is necessary to do service work with the engine running, make sure that the parking brake is applied fully and the transmission is in Neutral.
- Do not touch ignition wires or other ignition system parts when starting the engine or when the engine is running, or you could receive an electric shock.
- Be careful not to touch hot exhaust components such as the manifold, pipes, and mufflers.

**W WARNING**

- Do not allow smoking, sparks, or flames around gasoline or the battery. Flammable fumes are present.
- Do not get under your vehicle if it is supported only with the portable jack provided in your vehicle.
- Be careful not to cause accidental short circuits between the positive and negative battery terminals.
- Keep used oil, coolant, and other fluids away from children and pets. Dispose of used fluids properly; never pour them on the ground, into sewers, etc.

## TOOL KIT

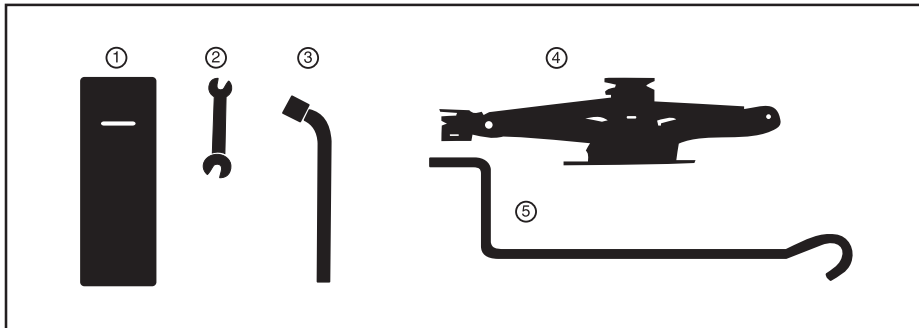

72F-09-001

The work tools illustrated here come with your vehicle. These tools can be used in your checkup or for minor repairs.

- 1 Tool bag
- 2 12×14 mm open end spanner
- 3 Wheel nut wrench
- 4 Jack
- 5 Jack handle

## PERIODIC MAINTENANCE SCHEDULE

The following table shows when regular maintenance on your vehicle is required. This table shows in kilometers and months when inspections, adjustments, lubrication and other services should be performed.

<b>w</b> <b>WARNING</b>
-------------------------

<p><b>Maruti Suzuki recommends that maintenance on your Maruti Suzuki vehicle be performed by Maruti Suzuki Authorised Dealer/Service Station.</b></p>
--

<b>CAUTION</b>
----------------

<p><b>Whenever it becomes necessary to replace parts on your vehicle, it is recommended that you use MARUTI GENUINE PARTS (MGP).</b></p>
--



Interval: This interval should be judged by odometer reading or months, whichever comes first.	km (x 1,000) months	FREE INSPECTIONS			PERIODIC MAINTENANCE SERVICE AT COST						
		1	5	10	20	30	40	50	60	70	80
		1	6	12	24	36	48	60	72	84	96
<b>FUEL</b>											
1. Air cleaner	Paved-road Dusty condition	Clean every 5,000 km. Replace every 40,000 km. Clean every 2,500 km or as required. Replace every 40,000 km. More frequent replacement if dust condition is severe.									
2. Accelerator cable and Throttle shafts		–	I&L	I&L	I&L	I&L	I&L	I&L	I&L	I&L	I&L
3. Fuel tank cap, fuel lines & connections(leakage,damage)		–	I	–	–	–	I	–	–	–	I
4. Fuel filter (leakage)		I	I	I	I	I	R	I	I	I	R
<b>CLUTCH AND TRANSMISSION</b>											
1. Clutch pedal (play)		I	I	I	I	I	I	I	I	I	I
2. Clutch slipping (dragging or excessive damage)		I	I	I	I	I	I	I	I	I	I
3. Manual Transmission/Transfer and Differential oil (level, leakage)		I	I	I	R	I	R	I	R	I	R
<b>PROPELLER SHAFTS</b>											
1. Propeller shafts (play)		–	–	I	I	I	I	I	I	I	I
2. Universal joint (slack)		–	–	I	I	I	I	I	I	I	I
<b>BRAKE</b>											
1. Brake fluid (level, leakage)		I	I	I	R	I	R	I	R	I	R
2. Brake pedal (pedal-to-wall clearance)		I	I	I	I	I	I	I	I	I	I
3. Parking brake lever and cable (play, damage)		I	I	I	I	I	I	I	I	I	I
4. Brake drums & shoes		–	–	I	I	I	I	I	I	I	I
5. Brake shoe to drum clearance		Adjust every 5,000 km. More frequent adjustments if required.									
6. Master cylinder and wheel cylinder (oil leakage, boot kit)		I	I	I	I	I	R	I	I	I	R
7. Brake hoses and pipes (leakage, damage)		I	I	I	I	I	I	I	I	I	I

**INSPECTION AND MAINTENANCE**

797-74E-1

Omni MPI

Interval: This interval should be judged by odometer reading or months, whichever comes first.	km (x 1,000) months	FREE INSPECTIONS			PERIODIC MAINTENANCE SERVICE AT COST							
		1	5	10	20	30	40	50	60	70	80	
		1	6	12	24	36	48	60	72	84	96	
<b>WHEEL</b>												
1. Tyres (air pressure, abnormal wear, crack, ROTATION)			I&O	I&O	I&O	I&O	I&O	I&O	I&O	I&O	I&O	
2. Wheels (damage)												
3. Front wheel bearings (loose, damage)		-										
4. Rear wheel bearings (loose, damage)		-										
<b>FRONT AND REAR SUSPENSION</b>												
1. Suspension strut (oil leakage, damage)												
2. Suspension arms and knuckle supports (loose, damage)		-										
3. Rear spring (damage)		-										
4. Shock absorbers (oil leakage, damage)												
5. All bolts and nuts (loose)		-	T	T	T	T	T	T	T	T	T	
6. Suspension arms and Tension rods		-										
<b>STEERING</b>												
1. Steering wheel (play, loose)												
2. Steering gear box (loose, leakage)		-										
3. All rods and arms (loose, damage, wear)												
<b>ELECTRICAL</b>												
1. Battery electrolyte (level, leakage)												
2. Wiring harness connection (looseness, damage)		-										
3. Lighting system (operation, stains, damage)												
4. Horn (operation)												
5. System voltage		-										
<b>BODY</b>												
1. All chassis bolts and nuts (tighten)		-		T	T	T	T	T	T	T	T	
2. All Latches, Hinges & Locks (function)			I&L	I&L	I&L	I&L	I&L	I&L	I&L	I&L	I&L	
<b>ROAD TEST</b>												
1. Operation of Brakes, Gear shifting & speedometer												
2. Body and Chassis noise												



**W WARNING**

- All maintenance should be carried out with the ignition switch in the "OFF" position and the vehicle parked securely on the level ground unless otherwise specified.
- If you are in any way unsure of your ability to undertake a task, then do not start it but contact your Maruti Suzuki dealer to perform the work for you.

**W WARNING**

When the engine is running, keep hands, hair, clothing, tools, etc. away from the fan and water pump belt.

Make sure the water pump belt tension is correct. If the belt is too loose, insufficient battery charging, engine overheating, or excessive belt wear can result. When you press the belt with your thumb midway between the pulleys, the belt deflection should be within the specification below.

6 - 9 mm

The belt should also be examined to ensure that it is not damaged. If the belt needs to be replaced or adjusted, have it done by your MARUTI SUZUKI dealer.

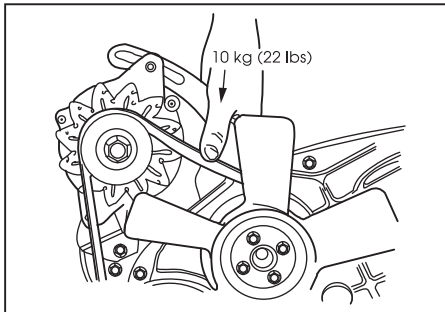
**WATER PUMP BELT**

797-09-001E

ENGINE OIL AND FILTER

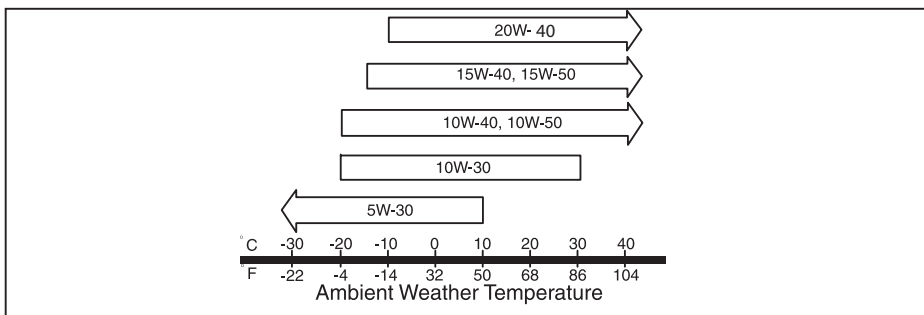

70F-07-004E

**Specified oil**

Be sure that the engine oil you use comes under the API classification of SF, SG or SH. The recommended engine oil is SF 20 W40 (1). Select the appropriate oil viscosity according to the above chart.

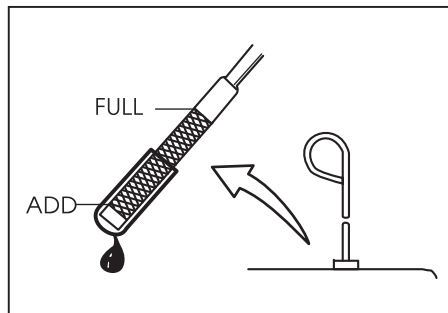

797-05-003E

**Oil Level Check**

It is important to keep the engine oil at the correct level for proper lubrication of your vehicle's engine. Check the oil level with the vehicle on a level surface. The oil level indication may be inaccurate if the vehicle is on a slope. The oil level should be checked either before starting the engine or at least five minutes after stopping the engine.

Pull out the oil dipstick, wipe oil off with a clean cloth, insert the dipstick all the way into the engine, then remove it again. The oil on the stick should be between the upper and lower limits shown on the stick. If the oil level indication is near the lower limit, add enough oil to raise the level to the upper limit.

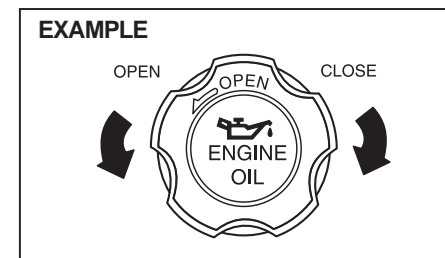

70F-07-008E

Omni MPI

**Refilling**

Remove the oil filler cap and pour oil slowly through the filler hole to bring the oil level to the upper limit on the dipstick. Be careful not to overfill. Too much oil is almost as bad as too little oil. After refilling, start the engine and allow it to idle for about a minute. Stop the engine, wait for two or three minutes and check the oil level again.

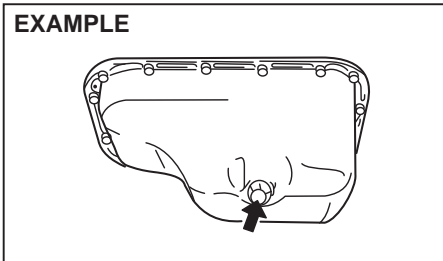
**EXAMPLE**

797-09-002

**Changing Engine Oil and Filter**

Drain the engine oil while the engine is still warm.

- 1) Remove the oil filler cap.
- 2) Place a drain pan under the drain plug.
- 3) Using the correct spanner remove the drain plug and drain out the engine oil.

**WARNING**

The engine oil temperature may be high enough to burn your fingers when the drain plug is loosened. Wait until the drain plug is cool enough to touch with your bare hands.

**WARNING**

New and used oil can be hazardous. Children and pets may be harmed by swallowing new or used oil. Keep new and used oil and used oil filters away from children and pets. Continuous contact with used engine oil has been found to cause (skin) cancer in laboratory animals. Brief contact with used oil may irritate skin.

To minimize your exposure to used oil, wear a long-sleeve shirt and moistureproof gloves (such as dishwashing gloves) when changing oil. If oil contacts your skin, wash thoroughly with soap and water. Launder any clothing or rags if wet with oil.

Recycle or properly dispose of used oil and filters.

- 4) Reinstall the drain plug and gasket. Tighten the plug to a torque of 1.8 - 2.8 kg-m (13.0 - 20.0 lb-ft).

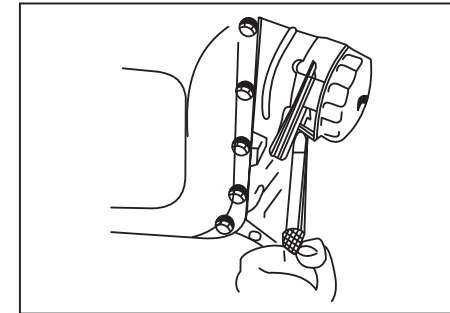

70F-07-010

**Replace the oil filter**

- 1) Using an oil filter wrench, turn the oil filter counterclockwise and remove it.
- 2) Using a clean rag, wipe off the mounting surface on the engine where the new filter will be seated.
- 3) Smear a little engine oil around the rubber gasket of the new oil filter.
- 4) Screw on the new filter by hand until the filter gasket contacts the mounting surface.

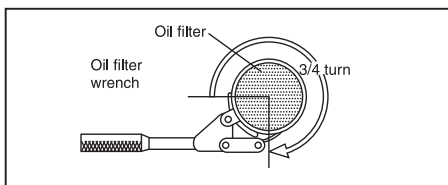

70F-07-011E

Tightening torque:

1.2 - 1.6 kg-m (8.5 - 11.5 lb-ft)

**CAUTION**

To tighten the oil filter properly, it is important to accurately identify the position at which the filter gasket first contacts the mounting surface.

- 5) Tighten the filter 3/4 turn from the point of contact with the mounting surface. (or to 1.2 – 1.6 kg-m) (8.5 - 11.5 lb-ft) using an oil filter wrench.

**CAUTION**

To prevent oil leakage, make sure that the oil filter is tight, but do not overtighten it.

**Refill with oil and check for leaks.**

- 1) Pour 2.5 litres of oil through the filler hole and install the filler cap.
- 2) Start the engine and look carefully for leaks at the oil filter and drain plug. Run the engine at various speeds for at least 5 minutes.
- 3) Stop the engine and wait for 5 minutes. Check the oil level again and add oil if necessary. Check for leaks again.

**CAUTION**

When replacing the oil filter, it is recommended that you use a genuine MARUTI replacement filter.

**CAUTION**

Oil leaks from around the oil filter or drain plug indicate incorrect installation or gasket damage. If you find any leaks or are not sure that the filter has been properly tightened, have the vehicle inspected by your MARUTI SUZUKI dealer.

**GEAR OIL**

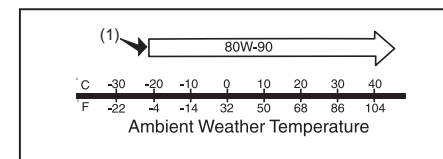

70F-07-013E

**Specified Transmission/Differential oil**

When adding gear oil, use the appropriate viscosity and grade as shown in the chart above. We highly recommend you use API GL-4 SAE 80W-90 gear oil.

Type of oil	Gear oil, API GL-4
-------------	--------------------

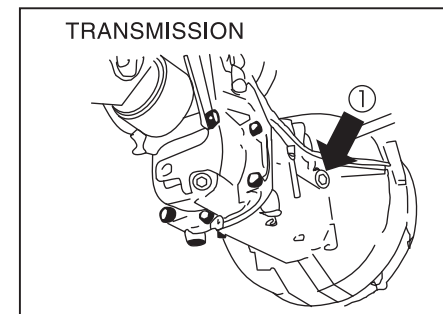

797-09-003E

Oil filler and level plug 1  
Tightening torque: 4.0 kg-m (29.0 lb-ft)

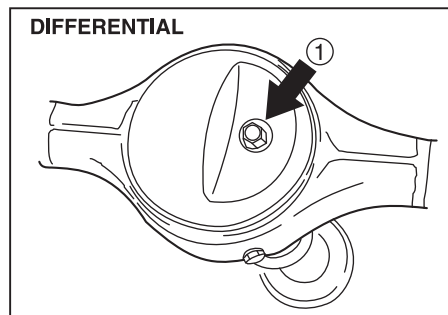

797-09-004E

Oil filler and level plug 1  
Tightening torque: 4.3 kg-m (31.0 lb-ft)

#### Transmission Oil/Differential oil level check

To check the gear oil level, use the following procedure:

- 1) Park the vehicle on a level surface with the parking brake applied.
- 2) Clean casing around oil filler plug to remove risk of any loose dirt or debris entering oil filler plug hole. Remove the oil filler plug 1 .

- 3) Feel the inside of the hole with your finger. If the oil level comes up to the bottom of the plug hole, the oil level is correct. If so, reinstall the plug.
- 4) If the oil level is low, add gear oil through the filler plug hole 1 until the oil level reaches the bottom of the filler hole, then reinstall the plug.

#### ⚠ WARNING

After driving the vehicle, the transmission oil temperature may be high enough to burn you. Wait until the oil filler plug is cool enough to touch with your bare hands before inspecting transmission oil.

#### CAUTION

- When tightening the plug, apply sealing compound to the plug threads to prevent oil leakage.

#### Gear oil change

Since special procedures, materials and tools are required, it is recommended that you trust this job to your authorized MARUTI SUZUKI dealer.

## ENGINE COOLANT

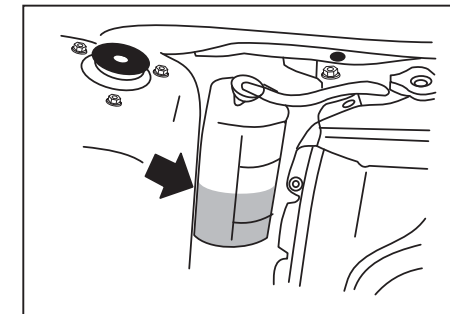

797-09-005

#### Coolant Level Check

Check the coolant level at the reservoir tank, not at the radiator. With the engine cool, the coolant level should be between the "FULL" and "LOW" marks.

#### Adding Coolant

If the Coolant level is below the "LOW" mark, more coolant should be added. Remove the reservoir tank cap and add coolant until the reservoir tank level reaches the "FULL" mark. Never fill the reservoir tank above the "FULL" mark.

**CAUTION**

When adding or replacing coolant, use a high quality ethylene glycol antifreeze and anticorrosion (Non-Amine type) diluted with distilled water. If the lowest ambient temperature in your area is expected to be  $-15^{\circ}\text{C}$  ( $5^{\circ}\text{F}$ ) or above, make the antifreeze concentration of the mixture you use at least 30% but no more than 50%. If  $-16^{\circ}\text{C}$  ( $3^{\circ}\text{F}$ ) or below, make the concentration at least 50%. If the 50% concentration does not provide adequate protection against freezing, follow the instructions on the antifreeze container to obtain the desired freezing point.

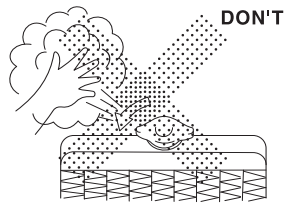

70F-07-018F

**WARNING**

It is dangerous to remove the radiator cap when the water temperature is high, because scalding fluid and steam may be blown out under pressure. Wait until the coolant temperature has lowered before removing the cap.

**Coolant Replacement**

Since special procedures, materials and tools are required, it is recommended that you trust this job to your authorized MARUTI SUZUKI dealer.

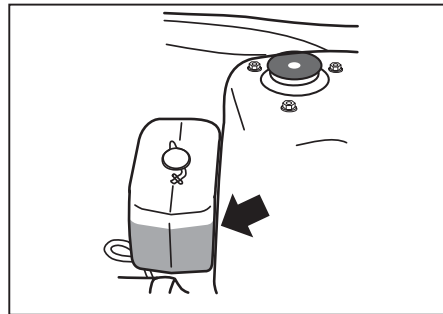
**WINDSCREEN WASHER FLUID**

797-09-007

Check that there is washer fluid in the tank. Refill it if necessary. Use a good quality windscreen washer fluid, diluted with water as necessary.

**WARNING**

Do not use "anti-freeze" solution in the windscreen washer reservoir. This can severely impair visibility when sprayed on the windscreen, and can also damage your vehicle's paint.

**CAUTION**

Damage may result if the washer motor is operated whilst the fluid or fluid nozzles are frozen or with no fluid in the washer tank.

## AIR CLEANER

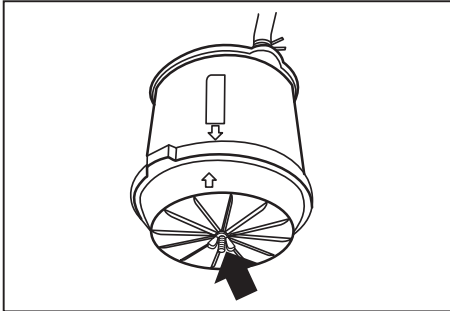

797-09-008

If the air cleaner is clogged with dust, there will be greater intake resistance, resulting in decreased power output and increased fuel consumption.

Take out the air cleaner element from air cleaner case, installed under the driver seat, after loosening the wingnut shown in the illustration. Blow off dust on air cleaner element by compressed air from inside of air cleaner. If the air cleaner element appears to be dirty, replace it with a new one.

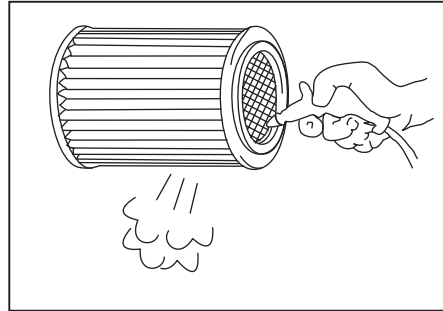

797-09-009

**CAUTION**

**The air cleaner element should be replaced every 40,000 km. More frequent replacement is necessary when you drive under dusty conditions.**

## SPARK PLUGS

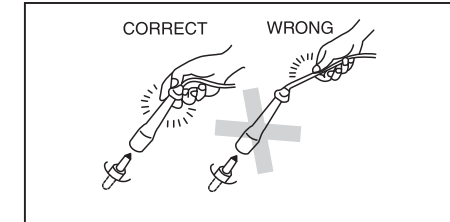

70F-07-025E

You should inspect spark plugs periodically for carbon deposits. When carbon accumulates on a spark plug, a strong spark may not be produced. Remove carbon deposits with a wire or pin and adjust the spark plug gap.

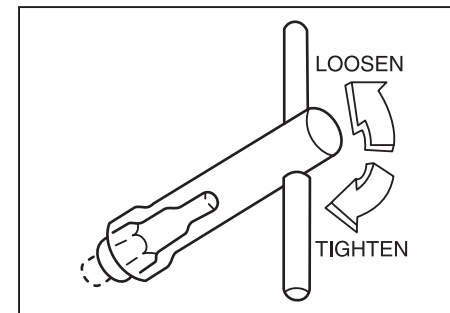

70F-07-026E

**CAUTION**

- When disconnecting the spark plug cables, pull on the boot, not on the cable itself. Pulling on the cable can damage it.
- When installing the spark plugs, screw them in with your fingers to avoid stripping the threads. Tighten with a torque wrench to 2.0–3.0 kg-m (20.0-30.0 N-m, 15.0-22.0 lb-ft). Do not allow contaminants to enter the engine through the spark plug holes when the plugs are removed.
- Never use spark plugs with the wrong thread size or length.

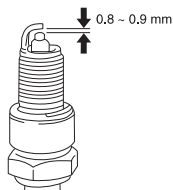

72F-09-005E

**CAUTION**

When replacing spark plugs, you should use the brand and type specified for your vehicle. For the specified plugs, refer to the "SPECIFICATIONS" section at the end of this book.

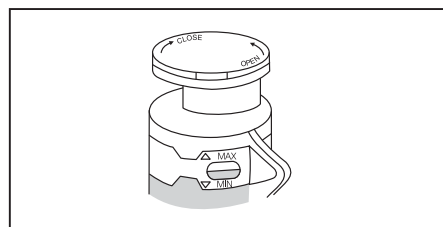
**BRAKES**

797-09-011

**Brake Fluid**

Remove the brake fluid reservoir lid on the instrument panel. Check the brake fluid level by looking at the reservoir. Check that the fluid level is between the "MAX" AND "MIN" lines. If the brake fluid level is near the "MIN" line, fill it up to the "MAX" line with MARUTI GENUINE brake fluid.



797-07-029

**w WARNING**

Failure to follow the guidelines below can result in personal injury or serious damage to the brake system.

- If the brake fluid in the reservoir drops below a certain level, the brake warning light on the instrument panel will come on (the engine must be running). Should the light come on, immediately ask your MARUTI SUZUKI dealer to inspect the brake system.
- A rapid fluid loss indicates a leak in the brake system which should be inspected by your MARUTI SUZUKI dealer immediately.

**w WARNING**

- ← Brake fluid can harm your eyes and damage painted surfaces. Use caution when refilling the reservoir.



**w WARNING**

Do not use any fluid other than **MARUTI GENUINE** brake fluid. Do not use reclaimed fluid or fluid that has been stored in old or open containers. It is essential that foreign particles and other liquids are kept out of the brake fluid reservoir.

**CAUTION**

The brake fluid should be replaced every two years or 40,000 km.

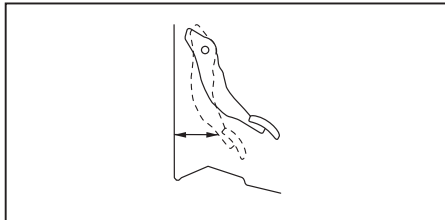

797-09-012

**Brake Pedal**

Measure the distance between the brake pedal and floor wall when the pedal is depressed with approximately 30 kg (66 lbs) of force. The minimum distance required

is 50 mm (2.0 in). If the pedal to floor wall distance as measured above is less than the minimum distance required, have your vehicle inspected/adjusted by your MARUTI SUZUKI dealer.

**NOTE:**

When measuring the distance between the brake pedal and floor wall, be sure not to include any floor covering in the measurement.

**w WARNING**

If you experience any of the following problems with your vehicle's brake system, have the vehicle inspected immediately by your MARUTI SUZUKI dealer.

- Poor braking performance
- Uneven braking (Brakes not working uniformly on all wheels.)
- Excessive pedal travel
- Brake dragging
- Excessive noise
- Pedal pulsation (Pedal pulsates when depressed.)

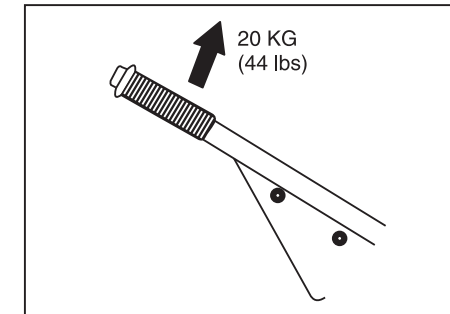

797-09-013E

**Parking brake**

Check the parking brake for proper adjustment by counting the number of clicks made by the ratchet teeth as you slowly pull up on the parking brake lever to the point of full engagement. The parking brake lever should stop between the 3rd and 8th ratchet tooth and the rear wheels should be securely locked. If the parking brake is not properly adjusted or the brakes drag after the lever has been fully released, have the parking brake inspected and/or adjusted by your MARUTI SUZUKI dealer.

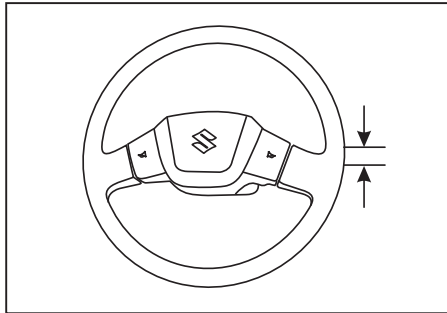
**STEERING**

797-09-015

Check the play of the steering wheel by gently turning it from left to right and measuring the distance that it moves before you feel slight resistance. The play should be between 10—30 mm (0.4—1.2 in).

Check that the steering wheel turns easily and smoothly without rattling by turning it all the way to the right and to the left while driving very slowly in an open area. If the amount of free play is outside the specification or you find anything else to be wrong, an inspection must be performed by your MARUTI SUZUKI dealer.

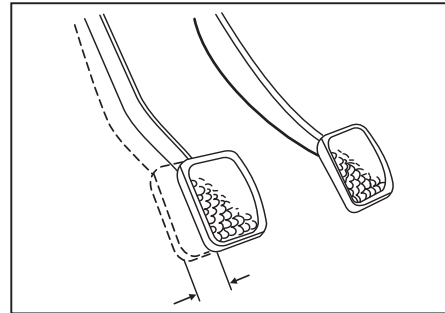
**CLUTCH PEDAL**

70F-07-034

Measure the clutch pedal play by moving the clutch pedal with your hand and measuring the distance it moves until you feel slight resistance. The play in the clutch pedal should be between 30—35 mm (1.2—1.4 in). If the play is more or less than the above, or clutch dragging is felt with the pedal fully depressed, have the clutch inspected by your MARUTI SUZUKI dealer.

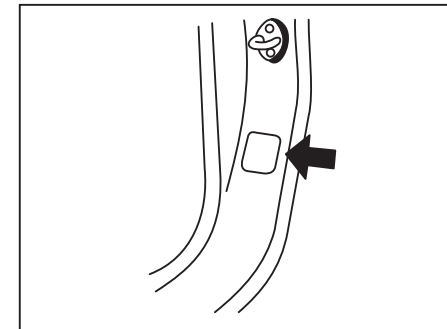
**TYRES**

70F07-035

The front and rear tyre pressure specifications for your vehicle are listed on the Tyre Inflation Pressure Label and in the "SPECIFICATIONS" section at the end of this book. Both the front and rear tyres should have the specified tyre pressure.

**Tyre Inspection**

Inspect your vehicle's tyres periodically by performing the following checks:

- 1) Measure the air pressure with a tyre gauge. Adjust the pressure if necessary.

**w WARNING**

- Air pressures should be checked when the tyres are cold or you may get inaccurate readings.
- Check the inflation pressure from time to time while inflating the tyre gradually, until the specified pressure is obtained.
- Never underinflate or overinflate the tyres.

Underinflation can cause unusual handling characteristics or can cause the rim to slip on the tyre bead, resulting in an accident or damage to the tyre or rim. Overinflation can cause the tyre to burst, resulting in personal injury. Overinflation can also cause unusual handling characteristics which may result in an accident.

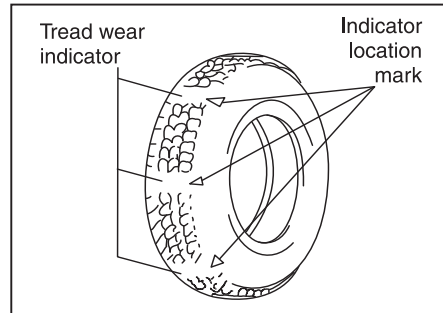

70F-07-037F

- 2) Check that the depth of the tread groove is more than 1.6 mm (0.06 in). To help you check this, the tyres have molded-in tread wear indicators in the grooves. When the indicators appear on the tread surface, the remaining depth of the tread is 1.6 mm (0.06 in) or less and the tyre should be replaced.
- 3) Check for abnormal wear, cracks and damage. Any tyres with cracks or other damage should be replaced. If any tyres show abnormal wear, have them inspected by your MARUTI SUZUKI dealer.

**w WARNING**

Hitting curbs and running over rocks can damage tyres and affect wheel alignment. Be sure to have tyres and wheel alignment checked periodically by your MARUTI SUZUKI dealer.

- 4) Check for loose wheel nuts.
- 5) Check that there are no nails, stones, or other objects sticking into the tyres.

**w WARNING**

Your MARUTI SUZUKI is equipped with tyres which are all the same type and size. This is important to ensure proper steering and handling of the vehicle. Never mix tyres of different size or type on the four wheels of your vehicle. The size and type of tyres used should be only those approved by MARUTI SUZUKI as standard or optional equipment for your vehicle.

**W WARNING**

Replacing the wheels and tyres equipped on your vehicle with certain combinations of aftermarket wheels and tyres can significantly change the steering and handling characteristics of your vehicle. Therefore, use only those wheel and tyre combinations approved by MARUTI SUZUKI as standard or optional equipment for your vehicle.

**CAUTION**

Replacing the original tyres with tyres of a different size may result in false speedometer or odometer readings.

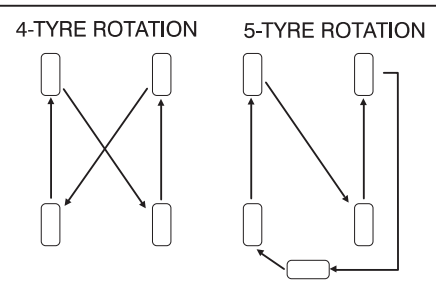

843-09-009E

**Tyre Rotation**

To avoid uneven wear of your tyres and to prolong their life, rotate the tyres as illustrated. Tyres should be rotated as mentioned in periodic maintenance schedule. After rotation, adjust front and rear tyre pressures to the specification listed on your vehicle's Tyre Inflation Pressure Label.

**Wheel Balancing**

If the vehicle vibrates abnormally on smooth road, have the wheel balanced at Maruti Suzuki Authorized Workshop.

**Wheel Alignment**

In case of abnormal tyre wear or pulling towards one side, have the wheel aligned at Maruti Suzuki Authorized Workshop.

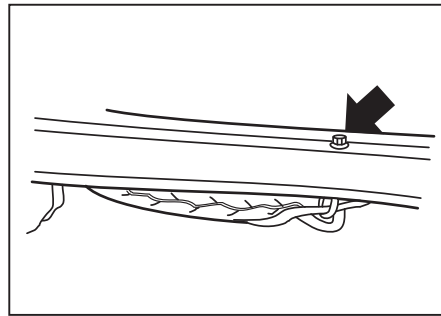

797-09-016

**Spare Wheel Stowage**

Spare wheel is stowed below the right sliding door. To take out the wheel, loosen the hanging bolt and then take out wheel.

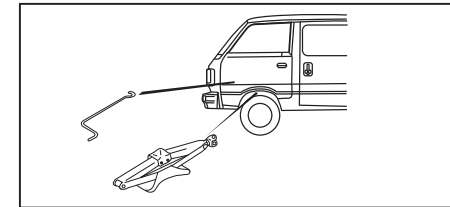

797-06-015

**Changing Wheels**

To change a wheel, use the following procedure:

- 1) Remove the jack, tools and spare wheel from the vehicle
- 2) Loosen, but do not remove the wheel nuts.
- 3) Jack up the vehicle (follow the jacking instructions in the EMERGENCY SERVICE section in this manual)
- 4) Remove the wheel nuts and wheel.
- 5) Before installing the new wheel, clean any mud or dirt off from the surface of the wheel and hub with a clean cloth. Clean the hub carefully; it may be hot from driving.

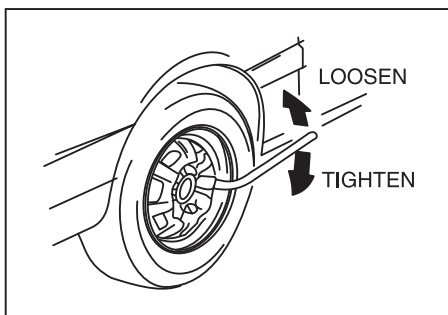

70F-07-039E

- 6) Install the new wheel and replace the wheel nuts with their cone shaped end facing the wheel. Tighten each nut snugly by hand until the wheel is securely seated on the hub.

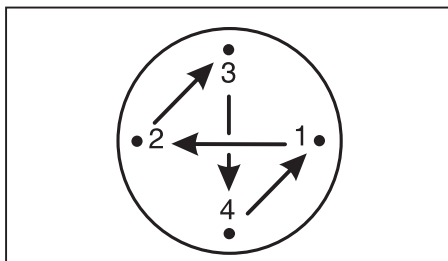

70F-07-040

- 7) Lower the jack and fully tighten the nuts [4.0–7.0 kg-m (28.9-50.5 lb-ft)] in a criss-cross fashion with a wrench as shown in the illustration.

**w WARNING**

**Use Maruti genuine wheel nuts and tighten them to the specified torque as soon as possible after changing wheels. Incorrect wheel nuts or improperly tightened wheel nuts may come loose or fall off, which can result in an accident. If you do not have a torque wrench, have the wheel nut torque checked by a MARUTI SUZUKI authorized dealer.**

**BATTERY**

**EXAMPLE**

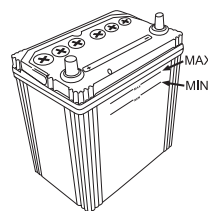

70F-07-041

**w WARNING**

**Batteries produce flammable hydrogen gas. Keep flames and sparks away from the battery or an explosion may occur. Never smoke when working in the vicinity of the battery.**

**w WARNING**

**When checking or servicing the battery, disconnect the negative cable. Be careful not to cause a short circuit by allowing metal objects to contact the battery posts and the vehicle at the same time.**

**w WARNING**

**To avoid harm to yourself or damage to your vehicle or battery, follow the jump starting instructions in the EMERGENCY SERVICE section of this manual if it is necessary to jump start your vehicle.**

The level of the battery solution must be kept between the "MAX" and the "MIN" level lines at all times. If the level is found to be below the "MIN" level line, add distilled water to the "MAX" level line. You should periodically check the battery, battery terminals, and battery hold-down bracket for corrosion. Remove corrosion using a stiff brush and ammonia mixed with water, or baking soda mixed with water. After removing corrosion, rinse with clean water.

If your vehicle is not going to be driven for a month or longer, disconnect the cable from the negative terminal of the battery to help prevent discharge.

### FUSES

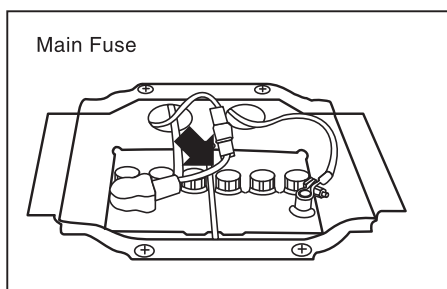

797-09-017E

This vehicle has two types of fuses, as described below :

**Main Fuse (fusible link)**-The main fuse takes current directly from the battery.

**Individual Fuses**-These fuses are in the fuse box and for individual electrical circuits.

#### Main Fuse (fusible link)

The main fuse is located on the battery positive terminal under the rear seat. If the main fuse blows, no electrical component will function. When replacing the main fuse, use a genuine MARUTI replacement.

#### WARNING

**If the main fuse blows, be sure to have your vehicle inspected by an authorized MARUTI SUZUKI dealer. Always use a genuine MARUTI replacement. Never use a substitute such as a wire even for a temporary repair, or extensive electrical damage and a fire can result.**

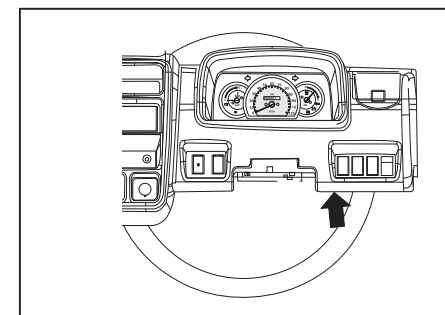

797-09-018

#### Fuse Box

The fuse box is located under the driver's side of the dashboard. Remove the fuse box cover by pushing in at both ends and pulling off the cover. To identify the amperage and location, refer to the fuse list shown on the back of the fuse box cover. To remove a fuse, hook the fuse with the end hook on the fuse box cover, and pull out the fuse.

**FUSE**

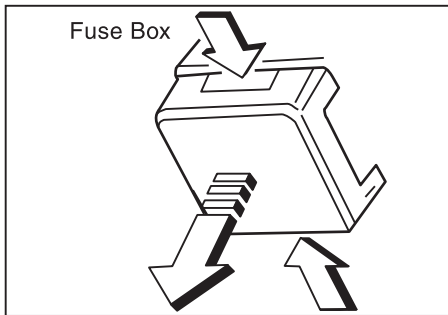

797-09-019E

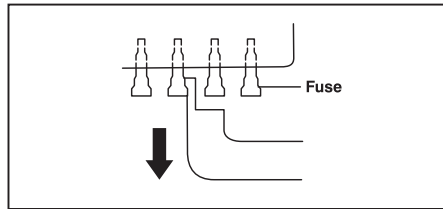

70F-07-045E

An addition fuse of 15 Amp for starter has been added near the fuse box under the dash board. For other fuses, refer Section "Inspection and Maintenance".

**NOTE:**  
Make sure that the fuse box always carries two spare fuses of 15A.

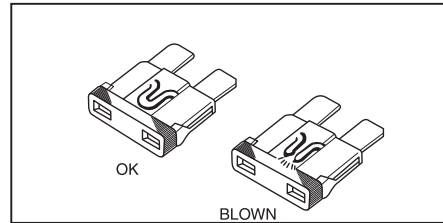

70F-07-046E

**WARNING**  
Always be sure to replace a blown fuse with a fuse of the correct amperage. Never use a substitute such as aluminium foil or wire to replace a blown fuse. If you replace a fuse and the new one blows in a short period of time, you may have a major electrical problem. Have your vehicle inspected immediately by your MARUTI SUZUKI dealer.

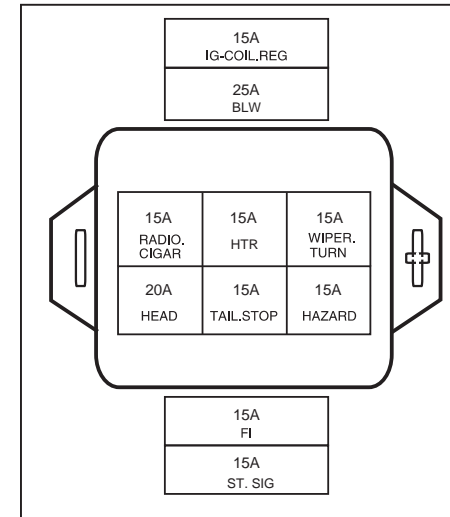

**BULB REPLACEMENT**

**CAUTION**  
Frequent replacement of a bulb indicates the need for an inspection of the electrical system. This should be carried out by your MARUTI SUZUKI dealer.

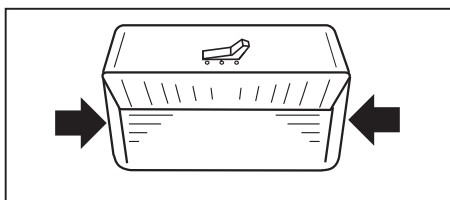

797-09-021

**Front/Center Interior Light**

Press the lens at the positions indicated by the arrows and remove it.

The bulb can be removed by simply pulling it out. When replacing the bulb, make sure that the contact springs are holding the bulb securely.

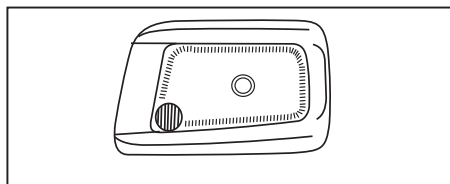

797-09-023

Remove the coupler 1, 2 and bulb holder 3. Then replace the bulb.

**NOTE:**  
Your vehicle is provided with two spare headlight bulbs for replacement in emergency.

**CAUTION**

**After bulb replacement, ensure rubber cover fitment by aligning 'TOP' marking with upperside of headlamp. If not properly fitted may lead to water entry in headlamp.**

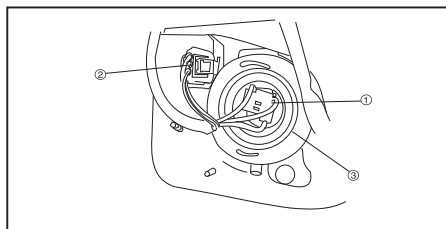

797-09-024E

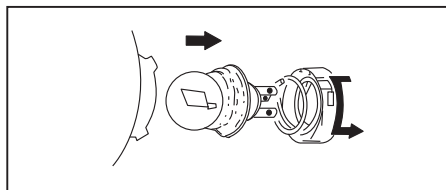

797-09-025

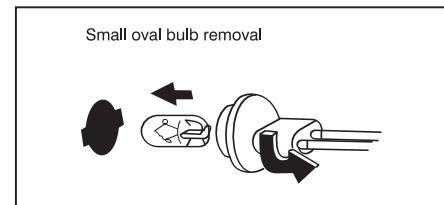

70F-07-050E

**Front Clearance/Turn Signal Light, Side Turn Signal Light, Rear Combination Light, Registration Plate Light.**

To remove a bulb holder from a light housing, turn the holder counterclockwise and pull it out. To install the holder, push the holder in and turn it clockwise.

Two types (small oval and round) of bulb are used for these lights. To remove and install a small oval bulb, simply pull out or push in the bulb.

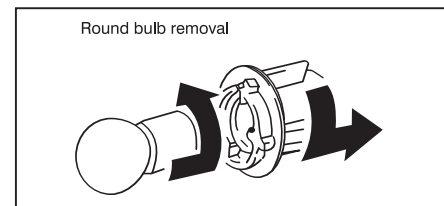

70F-07-051E



To remove a round bulb from a bulb holder, push in the bulb and turn it counterclockwise. To install a new bulb, push it in and turn it clockwise. You can access the individual bulb holders as described below:

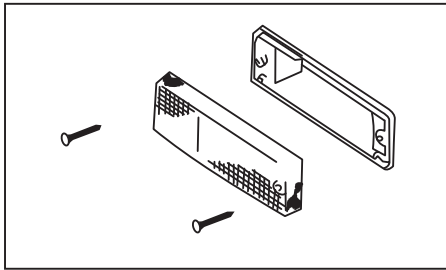

843-09-016

**Front turn signal/clearance light**  
Undo the two screws and remove the lens.

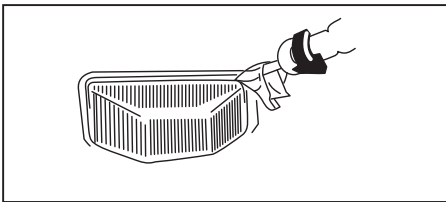

843-09-018

**Side turn signal light**

Remove the lens by using a plain screw driver covered with a soft cloth.

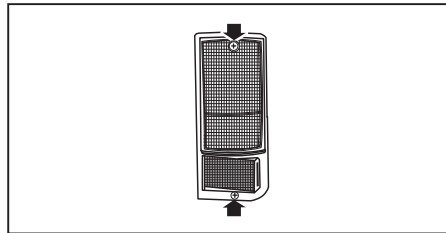

797-09-026

**Rear combination light (tail, stop, turn signal, etc.)**

Undo the two screws that secure the housing and remove the housing.

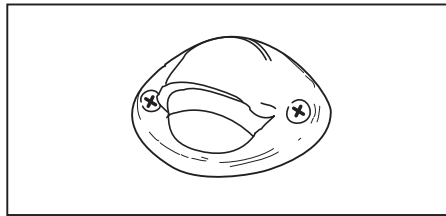

797-09-027

**Registration plate light**

Undo the two screws and remove the light housing.

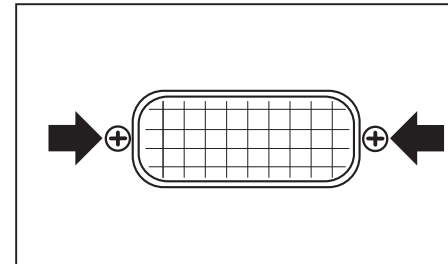

797-09-028

**Backup light**

Undo the two screws holding the back-up light and remove the lens.

**WIPER BLADES**

If the wiper blades become brittle or damaged, or make streaks when wiping, replace the wiper blades.

**CAUTION**

To avoid scratching or breaking the window, do not let the wiper arm strike the windshield while replacing the wiper blade.



## EMERGENCY SERVICE

Jacking Instructions .....	10-1
Jump Starting Instructions .....	10-2
Towing .....	10-3
Emergency Remedies .....	10-3
Warning triangle .....	10-5

## JACKING INSTRUCTIONS

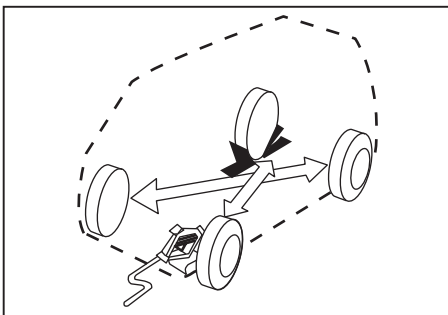

797-10-001

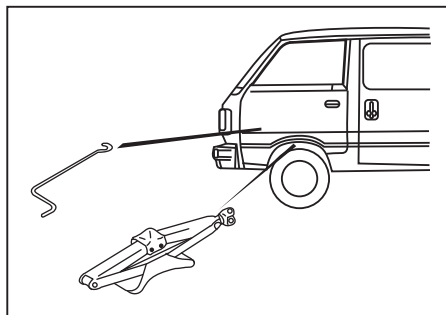

797-06-015

- 1) Park the vehicle securely on hard level ground.
- 2) Choke the front and rear wheel diagonally opposite the wheel to be changed.
- 3) Switch on the hazard warning flasher if your vehicle is in or near traffic.
- 4) Slacken but do not remove wheel nuts on the wheel to be changed.
- 5) Position the jack vertically and raise the jack by turning the jack handle clockwise until the jack head fits the front suspension arm or spring seat on rear axle.

- 6) Continue to raise the jack slowly and smoothly until the tyre clears the ground. Do not raise the vehicle more than necessary.

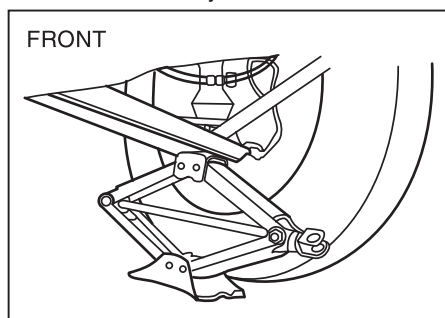

797-10-002E

**⚠ WARNING**

- Use the jack only to change wheels.
- Never jack up the vehicle on an inclined surface.
- Never raise the vehicle with the jack in a location other than the place specified in the illustration near the wheel to be changed.
- Make sure that the jack is raised at least 2 inches (51 mm) before it contacts the vehicle. Use of the jack when it is within 2 inches of being fully collapsed may result in failure of the jack. ⇨

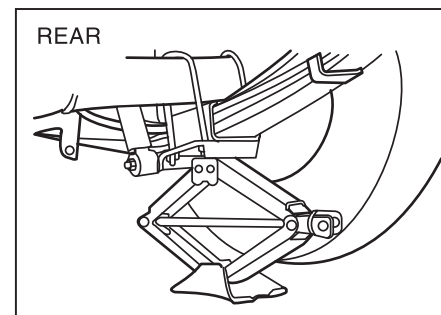

797-10-003E

## JUMP STARTING INSTRUCTIONS

**W WARNING**

- Never get under the vehicle when it is supported by the jack.
- Never run the engine when the vehicle is supported by the jack and never allow passengers to remain in the vehicle.

**W WARNING**

- Never attempt to jump start your vehicle if the battery appears to be frozen. Batteries in this condition may explode or rupture if jump starting is attempted.
- When making jump lead connections, be certain that your hands and the jump leads remain clear from pulleys, belts, or fans.
- Batteries produce flammable hydrogen gas. Keep flames and sparks away from the battery or an explosion may occur. Never smoke when working in the vicinity of the battery.

Continuos

**W WARNING**

- If the booster battery you use for jump starting is installed in another vehicle, make sure the two vehicles are not touching each other.
- If your battery discharges repeatedly, for no apparent reason, have your vehicle inspected by an authorized MARUTI SUZUKI dealer.
- To avoid harm to yourself or damage to your vehicle or battery, follow the jump starting instructions below precisely and in order. If you are in doubt, call for qualified road service.

**CAUTION****For fuel injection models**

- Vehicle equipped with electronic fuel injection system will not start by pushing or towing as the fuel pump will not work in this condition. This starting method could also result in permanent damage to the catalytic converter. Use jump leads to start a vehicle with a weak or flat battery.

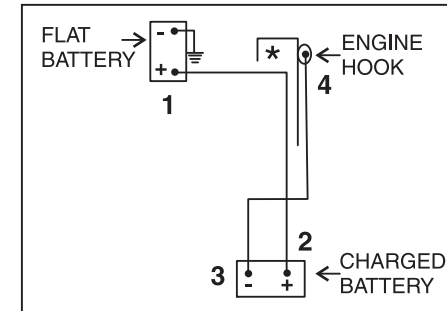

70F-08-004E

When jump starting your vehicle, use the following procedure:

- Use only a 12 volt battery to jump start your vehicle. Position the good 12V battery close to your vehicle so that the jump leads will reach both batteries. When using a battery installed on another vehicle, DO NOT LET THE VEHICLES TOUCH. Apply the parking brakes fully on both vehicles.
- Turn off all vehicle accessories, except those necessary for safety reasons (for example, headlights or hazard lights).

- 3) Make jump lead connections as follows:
  - a) Connect one end of the first jump lead to the positive (+) terminal of the flat battery.
  - b) Connect the other end to the positive (+) terminal of the booster battery.
  - c) Connect one end of the second jump lead to the negative (-) terminal of the booster battery.
  - d) Make the final connection to an unpainted, heavy metal part of the engine of the vehicle with the flat battery.

**w WARNING**

**Never connect the jump lead directly to the negative (-) terminal of the discharged battery, or an explosion may occur.**

- 4) If the booster battery you are using is fitted to another vehicle, start the engine of the vehicle with the booster battery. Run the engine at moderate speed.
- 5) Start the engine of the vehicle with the flat battery.
- 6) Remove the jump leads in the exact reverse order in which you connected them.

### TOWING

If you need to have your vehicle towed, contact a professional service.

**CAUTION**

**To help avoid damage to your vehicle during towing, proper equipment and towing procedures must be used.**

If the steering and drivetrain are in good condition, your vehicle should be towed from the rear with the rear wheels lifted and the front wheels on the ground. Your vehicle may be towed from the front with the front wheels lifted and dolly under rear wheels. Before towing, make sure the steering is unlocked and the transmission is in neutral.

### EMERGENCY REMEDIES

#### If the Starter Does Not Operate:

- 1) Try turning the ignition switch to the "START" position with the headlights turned on to determine the battery condition. If the headlights go excessively dim or go off, it usually means that either the battery is flat or the battery terminal contact is poor. Recharge the battery or correct battery terminal contact as necessary.
- 2) If the headlights remain bright, check the fuses. If the reason for failure of the starter is not obvious, there may be a major electrical problem. Have the vehicle inspected by your authorized MARUTI SUZUKI dealer.

#### If the Engine is Flooded

If the engine is flooded with petrol, it may be hard to start. If this happens, press the accelerator pedal all the way to the floor and hold it there while cranking the engine. (Do not operate the starter motor for more than 5 seconds). Release the accelerator as soon as the engine has started.

### the Engine Overheats

The engine could overheat temporarily under severe driving conditions. If the engine coolant temperature gauge indicates overheating during driving:

- 1) Turn off the air conditioner, if equipped.
- 2) Take the vehicle to a safe place and park.
- 3) Let the engine run at normal idle speed for a few minutes until the indicator is within the normal, acceptable temperature range between "H" and "C".

#### **W WARNING**

**If you see or hear escaping steam, stop the vehicle in a safe place and immediately turn off the engine to let it cool. Do not open the bonnet when steam is present. When the steam can no longer be seen or heard, remove the seats to see if the coolant is still boiling. If it is, you must wait until it stops boiling before you proceed.**

If the temperature indication does not come down to within the normal, acceptable range:

- 1) Turn off the engine and check that the water pump belt and pulleys are not damaged or slipping. If any abnormality is found, correct it.
- 2) Check the coolant level in the reservoir. If it is found to be lower than the "LOW" line, look for leaks at the radiator, water pump, and radiator hoses. If you locate any leaks that may have caused the overheating, do not run the engine until these problems have been corrected.
- 3) If you do not find a leak, carefully add coolant to the reservoir and then the radiator, if necessary. (Refer to "ENGINE COOLANT" in the "INSPECTION AND MAINTENANCE" section.)

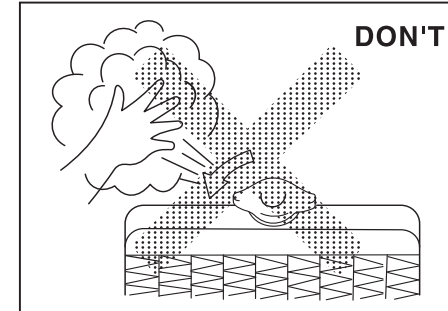

70F-07-019

#### **W WARNING**

**It is dangerous to remove the radiator cap when the water temperature is high, because scalding fluid and steam may be blown out under pressure. The cap should only be taken off when the coolant temperature has lowered.**

**w WARNING**

To help prevent personal injury, keep hands, tools and clothing away from the engine cooling fan and air-conditioner fan (if equipped). These electric fans can automatically turn on without warning.

**WARNING TRIANGLE**

In case of vehicle break-down or during emergency stopping where your vehicle could become a potential traffic hazard, keep the warning triangle, provided with your vehicle, on the road free from any obstacles behind your vehicle so as to warn the approaching traffic, at an approximate distance of 50-100m, the reflecting side of the triangle should face the on coming traffic. Please activate the hazard warning lamps before alighting the vehicle to keep the warning triangle.

- Remove the warning triangle carefully from the box as shown by arrow 1.
- Open both the reflector arms as shown by arrows and lock arms with each other with the clip provided in the right arm. Open the bottom stand in counter clock-wise direction as shown by arrow 3. Position the warning triangle behind the vehicle on a plain surface.
- Reverse the removal procedure for keeping inside the box.

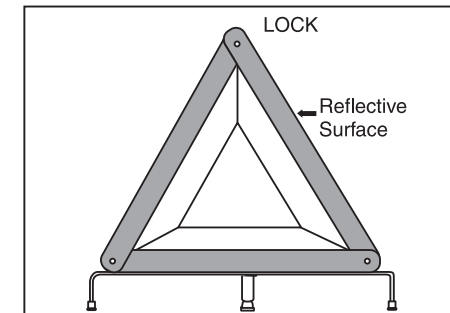
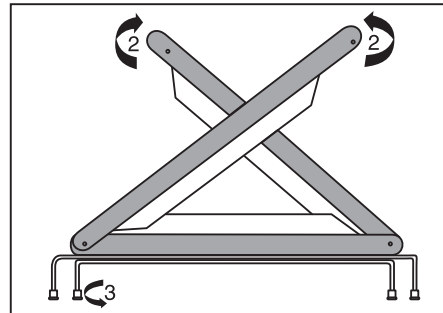
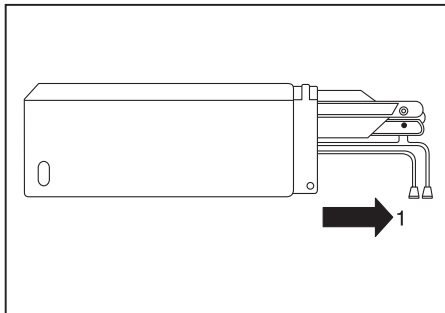



## **BODY WORK CARE**

<b>Corrosion Prevention .....</b>	<b>11-1</b>
<b>Vehicle Cleaning .....</b>	<b>11-2</b>

**CORROSION PREVENTION**

It is important to take good care of your vehicle to protect it from corrosion.

Listed below are instructions for how to maintain your vehicle to prevent corrosion. Please read and follow these instructions carefully.

**Important Information About Corrosion  
Common causes of corrosion**

- 1) Accumulation of road salt, dirt, moisture, or chemicals in hard to reach areas of the vehicle underbody or frame.
- 2) Chipping, scratches and any damage to treated or painted metal surfaces resulting from minor accidents or abrasion by stones and gravel.

**Environmental conditions which accelerate corrosion**

- 1) Road salt, dust control chemicals, sea air or industrial pollution will all accelerate the corrosion of metal.
- 2) High humidity will increase the rate of corrosion particularly when the temperature range is just above the freezing point.
- 3) Moisture in certain areas of a vehicle for an extended period of time may promote corrosion even though other body sections may be completely dry.
- 4) High temperatures will cause an accelerated rate of corrosion to parts

of the vehicle which are not well ventilated to permit quick drying.

This information illustrates the necessity of keeping your vehicle (particularly the underbody) as clean and dry as possible. It is equally important to repair any damage to the paint or protective coatings as soon as possible.

**How to Help Prevent Corrosion**

**Wash your vehicle frequently**

The best way to preserve the finish on your vehicle and to help avoid corrosion is to keep it clean with frequent washing. Wash your vehicle regularly during the winter and immediately after the winter. Keep your vehicle, particularly the underside, as clean and dry as possible. If you frequently drive on salted roads, your vehicle should be washed at least once a month during the winter. If you live near the ocean, your vehicle should be washed at least once a month throughout the year. For washing instructions, refer to the "VEHICLE CLEANING" section.

**Remove foreign material deposits**

Foreign material such as salts, chemicals, road oil or tar, tree sap, bird droppings and industrial fall-out may damage the finish of your vehicle if it is left on painted surfaces.

Remove these types of deposits as quickly as possible. If these deposits are difficult to wash off, an additional cleaner may be required. Be sure that any cleaner you use is not harmful to painted surfaces and is specifically intended for your purposes. Follow the manufacturer's directions when using these special cleaners.

**Repair finish damage**

Carefully examine your vehicle for damage to the painted surfaces. Should you find any chips or scratches in the paint, touch them up immediately to prevent corrosion from starting. If the chips or scratches have gone through to the bare metal, have a qualified body shop make the repair.

**Keep Passenger and luggage compartments clean.**

Moisture, dirt or mud can accumulate under the floor mats and may cause corrosion. Occasionally, check under these mats to ensure that this area is clean and dry. More frequent checks are necessary if the vehicle is used off road or in wet weather.

Certain cargos such as chemicals, fertilizers, cleaners, salts, etc., are extremely corrosive by nature. These products should be transported in sealed containers. If a spill or leak does occur, clean and dry the area immediately.

Omni MPI

## VEHICLE CLEANING

**Store your vehicle in a dry, well-ventilated area.**

Do not park your vehicle in a damp, poorly ventilated area. If you often wash your vehicle in the garage or if you frequently drive it in when wet, your garage may be damp. The high humidity in the garage may cause or accelerate corrosion. A wet vehicle may corrode even in a heated garage if the ventilation is poor.

**w WARNING**

**Do not apply additional undercoating or rust preventive coating on or around exhaust system components such as the exhaust pipes, etc. A fire could be started if the undercoating substance becomes overheated.**

**Cover your vehicle**

If you cannot regularly park your vehicle in a garage, we recommend you use a vehicle cover. Years of exposure to midday sun can cause the colours in paint, plastic parts, and fabrics to fade. Covering your vehicle with a high-quality, "breathable" vehicle cover can help protect the finish from the harmful UV rays in sunlight, and can reduce the amount of dust and air pollution reaching the surface.

**w WARNING**

**When cleaning the interior or exterior of the vehicle, NEVER USE flammable solvents such as lacquer thinners, petrol, benzene or cleaning materials such as bleach or strong household detergents. The materials could cause personal injury or damage to the vehicle.**

**Cleaning the Interior****Vinyl upholstery**

Prepare a solution of soap or mild detergent mixed with warm water. Apply the solution to the vinyl with a sponge or soft cloth and let it soak for a few minutes to loosen dirt. Rub the surface with a clean, damp cloth to remove dirt and the soap solution. If some dirt still remains on the surface, repeat this procedure.

**Fabric upholstery**

Remove loose dirt with a vacuum cleaner. Using a mild soap solution, rub stained areas with a clean damp cloth. To remove soap, rub the areas again with a cloth dampened with water. Repeat this until the stain is removed, or use a commercial

fabric cleaner for tougher stains. If you use a fabric cleaner, carefully follow the manufacturer's instructions and precautions.

**Seat Belts**

Clean seat belts with a mild soap and water. Do not use bleach or dye on the belts. They may weaken the fabric in the belts.

**Vinyl floor mats**

Ordinary dirt can be removed from vinyl with water or mild soap. Use a brush to help loosen dirt. After the dirt is loosened, rinse the mat thoroughly with water and dry it in the shade.

**Carpets**

Remove dirt and soil as much as possible with a vacuum cleaner. Using a mild soap solution, rub stained areas with a clean damp cloth. To remove soap, rub the areas again with a cloth dampened with water. Repeat this until the stain is removed, or use a commercial carpet cleaner for tougher stains. If you use a carpet cleaner, carefully follow the manufacturer's instructions and precautions.

**Cleaning the Exterior**

<b>CAUTION</b>
It is important that your vehicle be kept clean and free from dirt. Failure to keep your vehicle clean may result in fading of the paint or corrosion to various parts of the vehicle body.

**Washing**

<b>w WARNING</b>
<ul style="list-style-type: none"> <li>• Never attempt to wash and wax your vehicle with the engine running.</li> <li>• When cleaning the underside of the body and fender, where there may be sharp-edged parts, you should wear gloves and a longsleeved shirt to protect your hands and arms from being cut.</li> <li>• After washing your vehicle, carefully test the brakes before driving to make sure they have maintained their normal effectiveness.</li> </ul>

When washing the vehicle, follow the instructions below:

- 1) Flush the underside of body and wheel housings with pressurized water to remove mud and debris. Use plenty of water.

<b>CAUTION</b>
When washing the vehicle, avoid directing steam or hot water of more than 80°C (176°F) on plastic parts.

- 2) Remove dirt and mud from the body exterior with running water. You may use a soft sponge or brush. Do not use hard materials which can scratch the paint.
- 3) Wash the entire exterior with a mild detergent or car wash soap using a sponge or soft cloth. The sponge or cloth should be frequently soaked in the soap solution.

<b>CAUTION</b>
When using a commercial car wash product, observe the cautions specified by the manufacturer. Never use strong household detergents or soaps.

- 4) Once the dirt has been completely removed, rinse off the detergent with running water.
- 5) After rinsing, wipe off the vehicle body with a wet chamois or cloth and allow it to dry in the shade.
- 6) Check carefully for damage to painted surfaces. If there is any damage, "Touchup" the damage following the procedure below:
  - a) Clean all damaged spots and allow them to dry.
  - b) Stir the paint and "touchup" the damaged spots lightly using a small brush.
  - c) Allow the paint to dry completely.

**Waxing**

After washing the vehicle, waxing and polishing are recommended to further protect and beautify the paint.

- Only use waxes and polishes of good quality.
- When using waxes and polishes, observe the precautions specified by the manufacturers.

## VEHICLE IDENTIFICATION

## GENERAL INFORMATION

Vehicle Identification.....12-1

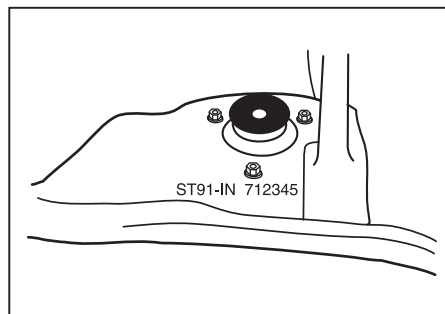
**Chassis Serial Number**

The chassis serial number stamped under the driver seat on the body as shown. The chassis and/or engine serial numbers are used to register the vehicle. They are also used to assist your dealer when ordering or referring to special service information. Whenever you have occasion to consult your MARUTI SUZUKI dealer, remember to identify your vehicle with this number. Should you find the number difficult to read, you will also find it on the identification plate.

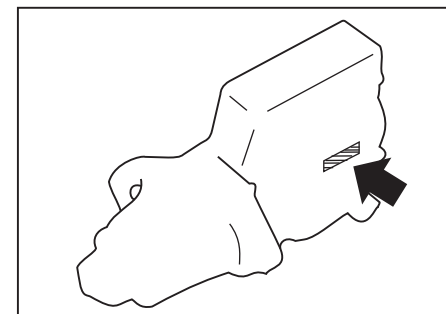
**Engine Serial Number**

The engine serial number is stamped on the cylinder block as shown in the illustration and also on the identification plate.

## SPECIFICATIONS

**NOTE :**

*Specifications are subject to change without notice.*

Omni MPI

DIMENSIONS	UNIT:mm	
	OMNI, OMNI-E, OMNI CARGO	OMNI XL, OMNI-E XL, OMNI CARGO-XL
Overall length	3,370	3,370
Overall width	1,410	1,410
Overall height	1,640	1,835
Wheelbase	1,840	1,840
Tread	1,205	1,205
	front	1,190
	rear	165
Ground clearance	165	165

MASS (WEIGHT)	UNIT:Kg							
	OMNI	OMNI-E	OMNI CARGO	OMNI XL	OMNI-E XL	OMNI CARGO-XL	AMBULANCE	
							OMNI	OMNI (XL)
Kerb mass (weight)	785	800	775	790	805	780	800	805
Gross vehicle mass (weight) rating	1285	1400	1400	1290	1405	1405	1285	1290
Seating Capacity	5 persons	8 persons	2 persons	5 persons	8 persons	2 persons	4+1 person in	
Goods Carrying Capacity	—	—	489	—	—	489	lying condition	

<b>ENGINE</b> Type Number of cylinders Bore Stroke Piston displacement Compression ratio	F8B - Four-stroke cycle, water cooled (SOHC) 3 68.5 mm 72.0 mm 796 cm <sup>3</sup> 8.7:1
<b>ELECTRICAL</b> Initial Ignition timing Standard spark plug Battery Fuses Headlight Turn signal light Side turn signal light Clearance light Tail/brake light Registration plate light Reversing light	5°±1° B.T.D.C. at 900 r/min CHAMPION - RN10YC, MICO - WR8DC 38B20R (28AH/5HR) See "INSPECTION AND MAINTENANCE" section 12V 45/40W 12V 21W 12V 5W 12V 5W 12V 5/21W 12V 5W 12V 10W

**SPECIFICATIONS**

797-74E-1

<b>WHEEL AND SUSPENSION</b> Tyre size, front and rear Tyre pressure            front/rear  Suspension type        front rear	145 R 12 LT 6PR UNLADEN - 2.0 kg/cm <sup>2</sup> LADEN    - 2.5 kg/cm <sup>2</sup> strut leaf spring
<b>STEERING</b> Toe-in	3-6 mm
<b>CAPACITIES</b> Coolant (Including reservoir tank) Fuel tank Engine oil Transmission oil Differential oil	4.0 L  36 L 2.7 L (Replacement with Oil Filter) 1.0 L 1.0 L

Omni MPI