

CONTENTS

Introduction to LPG	3
Safety Precautions (Do's & Dont's)	3
Location of Wagon-R LPG System Major Components	4
Fuel Modes	5
Selector Switch Position	5
Petrol Mode	5
Auto Mode	6
Forced LPG Mode	6
LPG Level Indicator (On Dashboard)	6
Automatic Changeover from LPG Mode to Petrol Mode	7
LPG Filling	7
LPG Cylinder	8
LPG Cylinder Warning Label	8
Manual Shut off Valve Knob	8
List of Government Approved LPG Cylinder Testing Stations	9
Jack Removal Procedure	9
Spare Wheel Location	10
Spare Wheel Removal Procedure	10
Instrument Cluster	11
LPG Malfunction Warning Lamp	12
Petrol Tank Capacity	12
LPG System Identification	12
LPG Fuses (Engine Compartment)	13
LPG Fuses (Under Dashboard)	13
LPG Warning Label	14
Periodic Maintenance Schedule	14
Specifications	16
Fire Extinguisher (if equipped)	17
Parts Description	18
Removal Procedure (from front & rear seat)	18
Procedure of Operation	19
Fitment Procedure	20
Refilling Schedules	20

FOR VEHICLES FITTED WITH LPG FUEL SYSTEM

FOR VEHICLES FITTED WITH LPG FUEL SYSTEM

INTRODUCTION TO LPG

LPG is a clean, high octane and eco-friendly fuel. It is basically a mixture of Butane and propane and is obtained from Natural Gas Fractionation and Crude Oil Refining.

LPG is a gas at atmospheric pressure, but can be liquidated when moderate pressure is applied or when the temperature is sufficiently reduced.

LPG produces less harmful exhaust gases as compared to petrol and diesel.

CAUTION

In case of any symptom of LPG leakage or releasing noise or any external damage to LPG piping or during accident, do not panic.

- **Stop the vehicle and switch off the engine, roll down the windows and open all the doors**
- **Ensure to close manual shut off valve.**
- **Contact Maruti Suzuki authorized workshop immediatly for further assistance.**

SAFETY PRECAUTIONS (Do's)

- Always repair your vehicle at Maruti Suzuki authorised workshop only.
- If engine does not start in LPG mode, start in Petrol mode and get the vehicle inspected by Maruti Suzuki authorised workshop.
- Ensure that the Gas tank Cover is always in closed position and not damaged. Replace the same as soon as damage is noticed.
- Ensure that conduit pipes are always in good condition and secured firmly. Replace in case damage is noticed.
- Get the Auto LPG cylinder checked periodically.
- If any Service or body repair is to be carried out, ensure to close Manual shut off valve on the multivalve. Then remove the Auto LPG cylinder from the vehicle.
- It is recommended to run the vehicle 5-10 Kilometers on Petrol after every 300-500 Kilometers run in LPG mode to keep the fuel system in good condition.
- Switch "OFF" engine before refilling LPG.

SAFETY PRECAUTIONS (Dont's)

- Never install any other gas cylinder in place of LPG cylinder.
- Do not change/modify the configuration settings or components from LPG system.
- The Auto LPG cylinder should never be repaired under any circumstances, in case of any problem, consult with Maruti Suzuki authorised workshop.
- Never carry inflammable material near Auto LPG cylinder.
- Never handle LPG system components. In case of replacement of any component, always contact Maruti Suzuki authorised workshop.
- Do not fill any other type of gas other than Auto LPG.
- Do not try to fill more than 22.4 Lts of LPG.
- Do not use Domestic LPG in your vehicle.
- Do not press the accelerator pedal to change from petrol to LPG mode.

FOR VEHICLES FITTED WITH LPG FUEL SYSTEM

LOCATION OF WAGON-R LPG SYSTEM MAJOR COMPONENTS

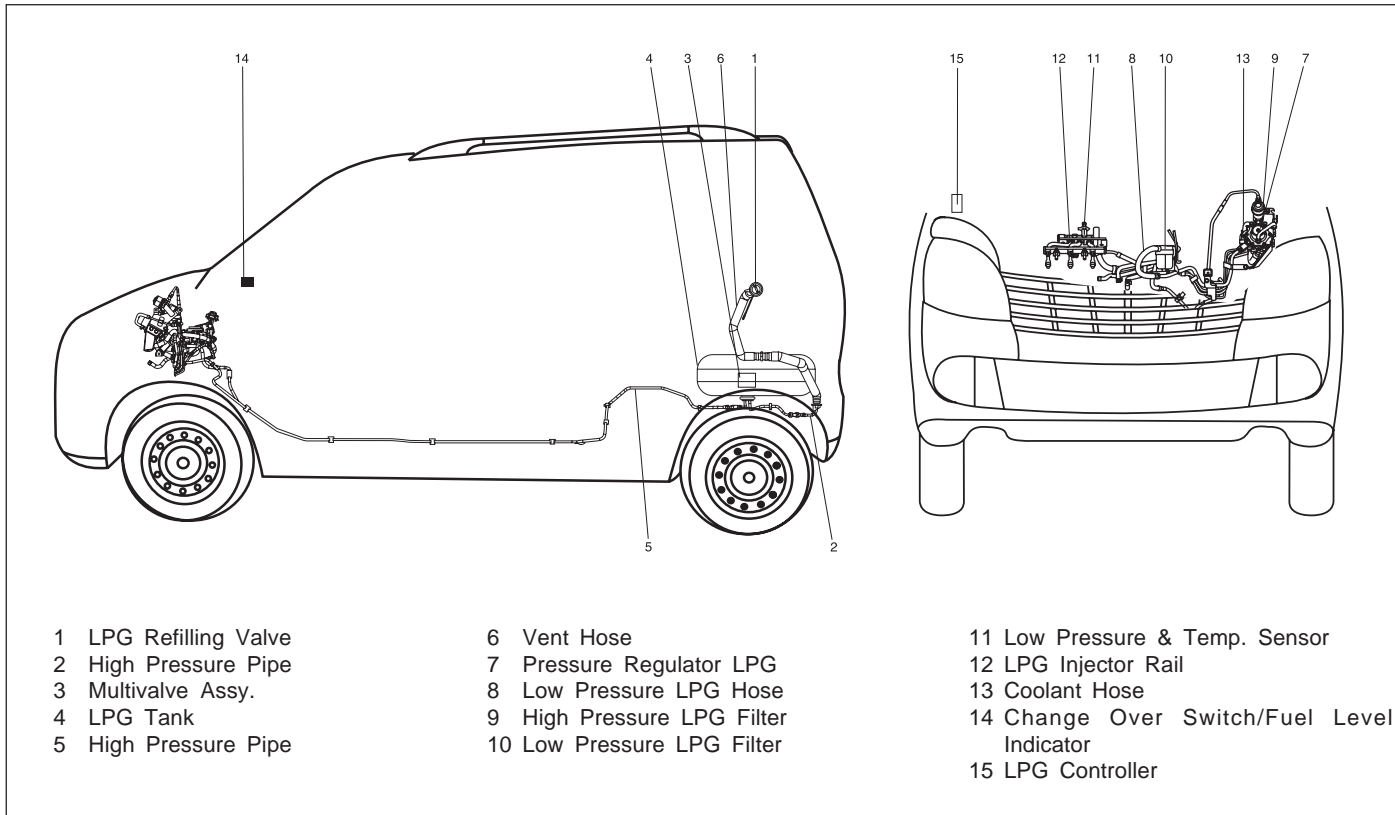

FOR VEHICLES FITTED WITH LPG FUEL SYSTEM

FUEL MODES

There are three fuel modes in the vehicle (Petrol, Auto and Forced LPG) which are selectable by pressing the selector switch (1) located on the right side of the steering wheel on the dashboard.

▲ WARNING

Make sure that the parking brake is applied fully and the transmission is in Neutral before attempting to start the engine.

CAUTION

- **Stop cranking the engine immediately after the engine has started or the starter system can be damaged.**
- **Do not crank the engine for more than 15 seconds at a time. If the engine doesn't start on the first try, wait for about 15 seconds before trying again.**

NOTE:

- *Do not press the accelerator pedal to changover from petrol to LPG mode.*

SELECTOR SWITCH POSITION

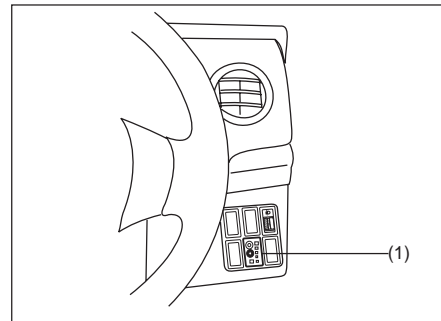

PETROL MODE

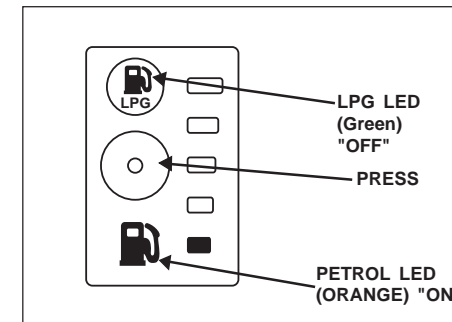

In this mode vehicle starts in petrol and continue running in petrol mode. In this mode, petrol indicator glows continuously in ORANGE color and LPG indicator (GREEN) will remain "OFF".

When the vehicle is running in this mode, it can be shifted to LPG mode by pressing the changeover switch.

FOR VEHICLES FITTED WITH LPG FUEL SYSTEM

AUTO MODE

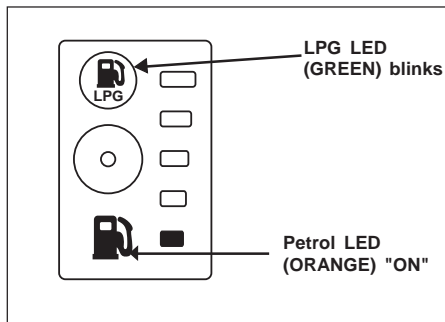

In this mode engine starts in petrol mode and then automatically changes to LPG after reaching programmed warming up condition. With ignition switch ON and vehicle started in "AUTO MODE", LPG indicator blinks (Green Color), and PETROL indicator glows (Orange color) continuously. After changeover to LPG, LPG indicator will glow continuously and Petrol indicator switches off automatically.

NOTE:

- It is always recommended to start the vehicle in AUTO MODE or PETROL MODE to enhance the engine life.
- The fuel changeover to LPG will not happen if the vehicle is started at the time when the coolant temperature is below zero deg. C.

FORCED LPG MODE

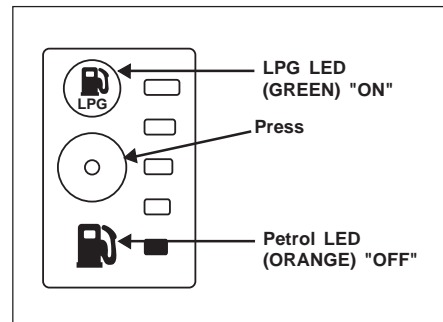

This is emergency mode and may be used in cases where there is no petrol in petrol tank. In this mode vehicle starts in LPG and continues running in LPG mode. With ignition "ON" and engine not running, press and hold the changeover switch till LPG indicator glows continuously. In this mode, LPG indicator glows continuously in GREEN color and Petrol indicator (ORANGE) remains "OFF".

NOTE:

- It is recommended to keep sufficient amount of petrol in the petrol tank.
- The vehicle will not start in Forced LPG mode if the coolant temperature is below zero deg C.

LPG LEVEL INDICATOR (On Dashboard)

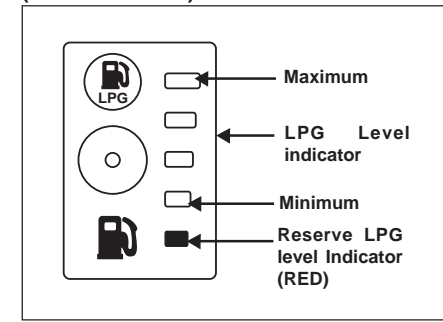

LPG level indicator is built into the changeover switch. It consists of four green and one red LEDs, which indicates approximate amount / level of remaining LPG in the cylinder. Red LED of LPG level indicator glows when reaches to reserve quantity.

NOTE:

- When LPG reserve level indicator glows, refill LPG as soon as possible.

FOR VEHICLES FITTED WITH LPG FUEL SYSTEM

AUTOMATIC CHANGEOVER FROM LPG MODE TO PETROL MODE

When Auto LPG is emptied while the engine is running, vehicle automatically changes from LPG mode to Petrol mode and LPG malfunction warning lamp starts blinking. Petrol indicator (ORANGE color) glows continuously and LPG indicator (GREEN color) gets switched OFF automatically.

To stop this alert, press the changeover switch once. LPG malfunction warning lamp will stop blinking and Petrol indicator (ORANGE color) will glow continuously. However, LPG malfunction warning lamp will continue to blink after every subsequent Ignition ON - Ignition OFF condition, until the vehicle is refilled with atleast 8 liters of LPG.

NOTE:

- *It is recommended to keep atleast 5 litres of petrol in the petrol tank to prevent engine stalling while automatic changeover from LPG mode to Petrol mode.*
- *In case the LPG malfunction warning lamp does not stop blinking after pressing the changeover switch, have the vehicle inspected at the nearest MARUTI SUZUKI dealer.*

- *In case LPG is refilled in an empty tank, ensure that minimum 8 liters of LPG is filled as it is required for system to changeover from Auto mode to LPG mode. In case less than 8 liters of LPG is filled in an empty tank, vehicle may continue to run on Petrol mode only.*

LPG FILLING

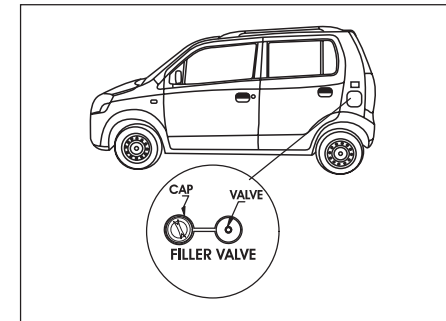

LPG filler Valve is installed on left hand side of your vehicle. LPG Filling will stop automatically once cylinder is filled upto 80% of the capacity.

The cylinder fitted in your vehicle is of 28 litres water capacity. When filling an empty cylinder, it is advised to fill maximum 22.4 litres of LPG in the tank of your vehicle. In case, filling is being done after removal and /or fitment of Auto LPG cylinder, for testing the LPG cylinder as per govt. regulation, have the joints checked for leakage by applying soap solution or leak detector by Maruti Suzuki authorised workshop.

FOR VEHICLES FITTED WITH LPG FUEL SYSTEM

CAUTION

- Do not fill more than 22.4 litres of LPG in tank.
- Usage of Domestic LPG is legally prohibited and can cause serious damage to the vehicle.

LPG CYLINDER

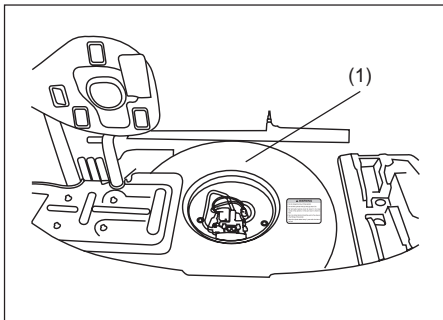

LPG cylinder (1) is installed below the luggage floor carpet in the luggage compartment.

NOTE:

- Do not load sharp and heavy objects in the rear luggage area.

LPG CYLINDER WARNING LABEL

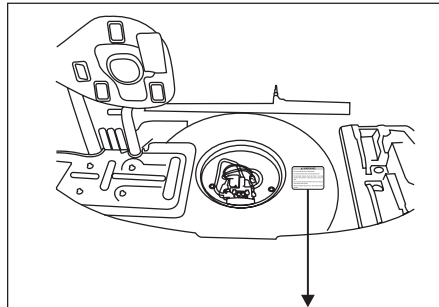

▲ WARNING

- Do not change the colour of this cylinder.
- Do not fill this cylinder with any other gas than LPG.
- No flammable material should be stored in the close vicinity of this cylinder or in the same room in which it is kept.
- No oil or similar lubricant should be used on the valves or other fittings of this cylinder.
- Have this cylinder tested every 5 years after the date of last test.

You may find this label on the LPG cylinder.

MANUAL SHUT OFF VALVE KNOB

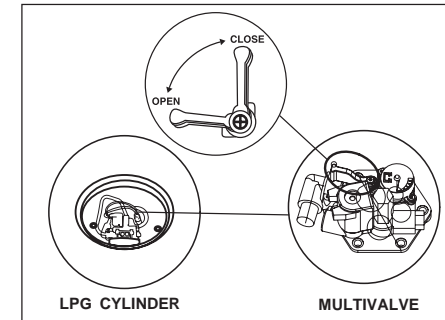

The Manual shut off valve knob (Yellow in colour) is located on Multivalve, on the Auto LPG cylinder. The knob should always be in open position to allow the flow of LPG to engine. In the close position of the lever, LPG supply to the engine is stopped.

The manual shut off valve knob must be closed in case of any repair in the LPG system parts or any symptoms of leakage.

NOTE:

- If the manual shut off valve is not opened fully, then engine may not run properly.
- If the manual shut off valve is in closed position, it is not possible to fill LPG into the cylinder.

FOR VEHICLES FITTED WITH LPG FUEL SYSTEM

NOTE:

- As per Government regulation, LPG cylinder needs to be checked and certified every five (5) years from the date of last retest as mentioned on the LPG cylinder identification plate.
- Customer has to present the vehicle to a government approved testing agency.
- Failure to test the cylinder may result in denying of LPG filling by the LPG dispensing stations or may result in confiscating the vehicle by enforcement authorities.
- All the expenses for LPG cylinder testing has to be borne by the customer.
- As per Government regulation, LPG cylinder has to be discarded at 15 years from the date of initial testing as mentioned in the LPG cylinder identification plate.
- Customer has to discard the cylinder at his / her expense through government approved scrap agencies.
- No person shall refill any cylinder, which has been repaired under sub-rule (2) with any gas unless a full report on the repairs and test carried out on the cylinder, accompanied by the repairer's certificate of testing are furnished to the Chief Controller and his permission is obtained for its refilling.

⚠ WARNING

- Never remove the Multi-valve from the cylinder assembly. For any assistance consult Maruti Suzuki authorized workshop.
- Never try to clean the cylinder. In case of any problem, contact Maruti Suzuki authorized workshop.
- Do not reuse the multivalve, once it is replaced / removed from cylinder assembly, during re-certification of LPG tank, without changing gasket and multivalve screw.
- Even if the LPG from the cylinder is consumed till engine stops, some amount of LPG will be left out in the tank under pressure.

LIST OF APPROVED LPG CYLINDERS TESTING STATIONS

To obtain testing stations information visit the following internet website address :
"www.peso.gov.in"

JACK REMOVAL PROCEDURE

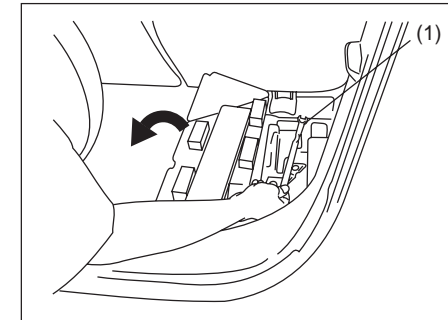

Jack (1) is located below the luggage floor carpet.

NOTE:

To access the JACK it is NOT required to take out luggage floor carpet completely. Flap is provided separately for easy access of tool Kit.

FOR VEHICLES FITTED WITH LPG FUEL SYSTEM

SPARE WHEEL LOCATION

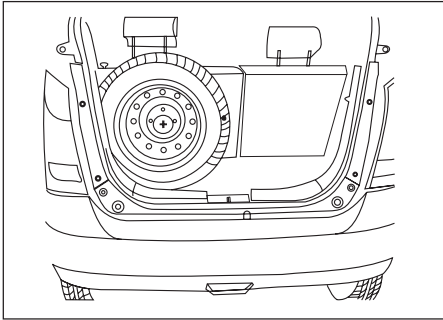

Spare wheel is located behind the rear left hand Seat, fitted on a bracket and tightened with help of a locking knob.

SPARE WHEEL REMOVAL PROCEDURE

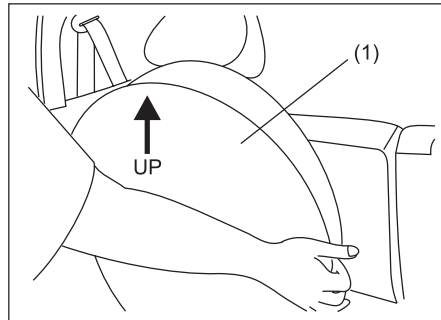

(a) Remove spare wheel cover (1) by lifting upside.

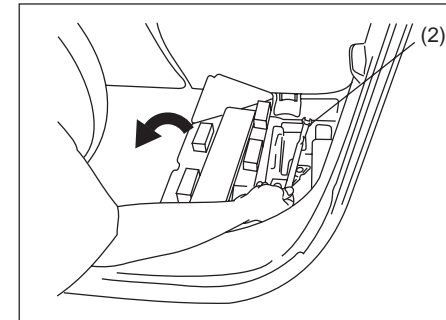

(b) Take out the wheel wrench (2) from utility box by just rotating/lifting the flap, provided in the luggage floor carpet.

NOTE:

To access the utility box it is NOT required to take out luggage floor carpet completely. Flap is provided separately for easy access of tool Kit.

INSTRUMENT CLUSTER

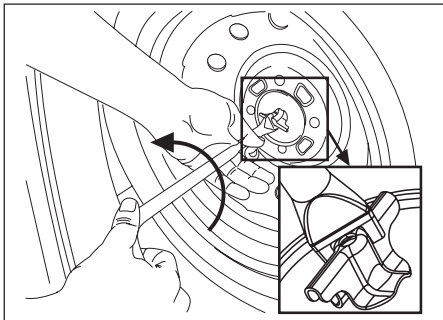

(c) Engage the notch provided end with screw & rotate in anticlockwise direction as shown.

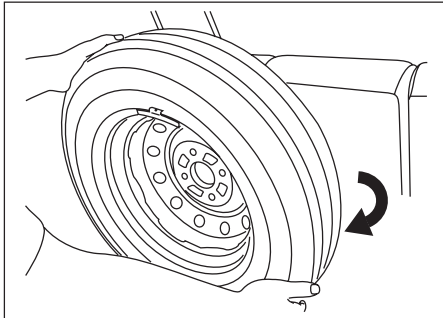

(d) Take out the spare wheel in the direction as shown in figure.

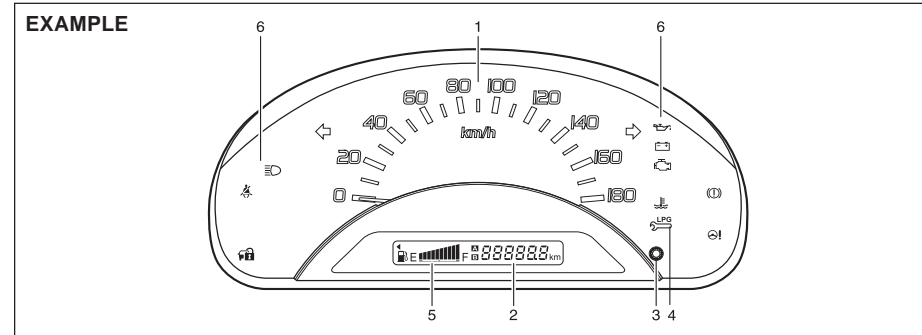

- 1) Speedometer
- 2) Odometer / Tripmeter
- 3) Odometer / Tripmeter selector knob
- 4) LPG malfunction warning Indicator lamp
- 5) Fuel Indicator
- 6) Warning and Indicator lights (if equipped)

FOR VEHICLES FITTED WITH LPG FUEL SYSTEM

LPG MALFUNCTION WARNING LAMP

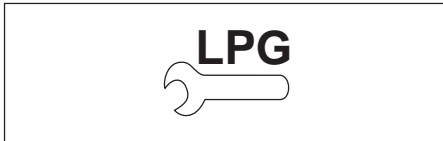

When the ignition switch is turned "ON", this LPG malfunction warning lamp comes on briefly, to check that the LPG system is troublefree.

- If LPG malfunction warning lamp glows continuously, with ignition "ON" there is some problem with the LPG system. Immediately get your vehicle checked by Maruti Suzuki authorized workshop.
- If LPG malfunction warning lamp blinks during engine running, it means there is some problem in LPG system in which vehicle cannot continue running on LPG and automatically switchover to petrol mode. Have your vehicle checked at Maruti Suzuki authorized workshop.

PETROL TANK CAPACITY

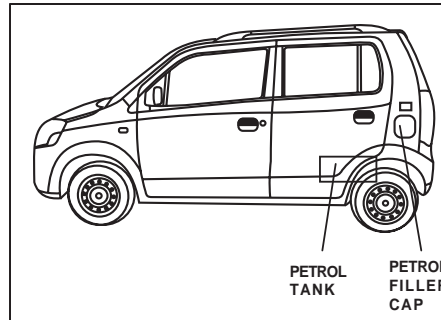

Your vehicle is fitted with petrol tank of 35 litres capacity.

NOTE :

The tank should always have sufficient quantity of petrol.

LPG SYSTEM IDENTIFICATION

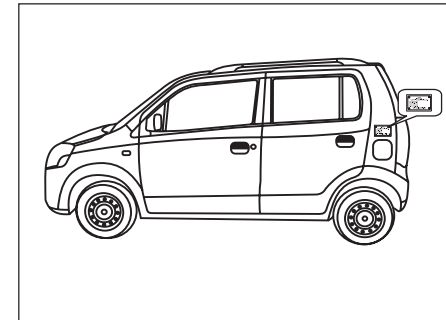

LPG cylinder Identification number and LPG kit installation date is located near the LPG filler valve.

FOR VEHICLES FITTED WITH LPG FUEL SYSTEM

LPG FUSES (Engine Compartment)

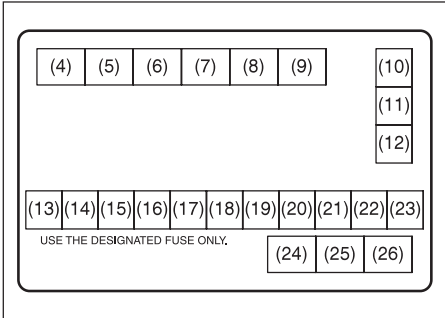
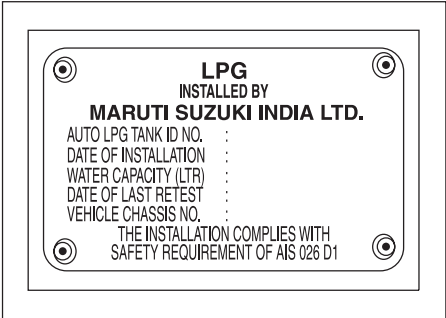

LPG FUSES (Under Dashboard)

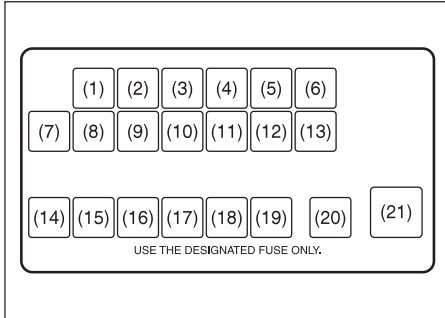

- 6) LPG VLV Relay -
- 15) LPG VLV Fuse 7.5A

- 7) LPG Fuse 7.5A

⚠ WARNING
 Always be sure to replace a blown fuse with the fuse of correct amperage. Never use a substitute such as aluminium foil or wire to replace a blown fuse. If you replace a fuse and the new fuse blows in a short period of time, have your vehicle inspected immediately by your Maruti Suzuki authorised workshop.

FOR VEHICLES FITTED WITH LPG FUEL SYSTEM

LPG WARNING LABEL

Front Driver door

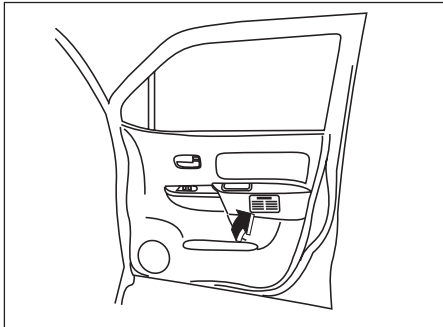

Rear Right door

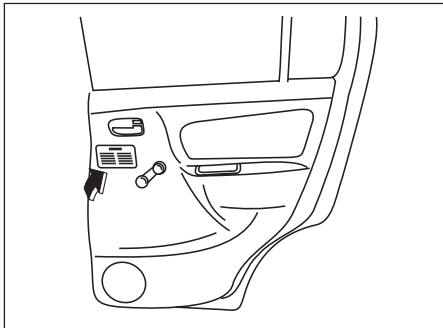

▲ WARNING

SAFETY INSTRUCTIONS

- LPG is FLAMMABLE, keep away from fire.
- In case of LPG leakage.
 - Stop vehicle and switch off engine.
 - Close manual shut-off valve on LPG Cylinder.
 - Do not run vehicle even in petrol.
 - Have your vehicle inspected at Maruti Suzuki authorized workshop at the earliest.
- Switch off engine before refilling LPG.
- Using Domestic LPG is legally prohibited and can cause serious damage to the vehicle.
- Read owner's manual for more information.

Emergency Nos.-Police:100, Fire:101, Ambulance:102

LPG warning label is located on front and rear Right side doors.

PERIODIC MAINTENANCE SCHEDULE

NOTE :

The interval should be judged by odometer reading. Over and above the regular maintenance schedule described in the main owner's manual (supplied with the vehicle) following has to be checked only by Maruti Suzuki authorised workshop.

Check Auto LPG cylinder every five years at Government approved LPG cylinders testing agency.

For periodic maintenance refer next page.

FOR VEHICLES FITTED WITH LPG FUEL SYSTEM

PERIODIC MAINTENANCE SCHEDULE

Kms (1 X 1000)	1	5	10	20	30	40	50	60	70	80	90	100
Month	1	6	12	24	36	48	60	72	84	96	108	120
All Joints (Gas leakage)	I	I	I	I	I	I	I	I	I	I	I	I
Low Pressure LPG Filter Cartridge with O-Rings	-	-	R	R	R	R	R	R	R	R	R	R
Coolant Hoses (Leakage,Damage)	I	I	I	I	I	I	I	I	I	I	I	I
High Pressure LPG Filter Cartridge of LPG Regulator with O-Rings	-	-	R	R	R	R	R	R	R	R	R	R
LPG Pressure Regulator Overhauling:- Diaphragm replacement with O-Rings & solenoid plunger Cleaning	-	-	-	-	-	R	-	-	-	R	-	-
All Fasteners Torque values for Bracket, LPG Pressure Regulator, LPG Filter, LPG Tank & all LPG Pipe joints.	T	T	T	T	T	T	T	T	T	T	T	T

T Tighten to Specified Torque

I Inspect and correct or replace if necessary

R Replace

Note:

- This table includes services as scheduled up to 100,000 km mileage. Beyond 100,000 km, carry out the same services at the same intervals respectively.
- For other maintenance details refer "Inspection & Maintenance" section in main Owner's Manual.
- For relays and fuse of Petrol system refer "Inspection & Maintenance" section in main Owner's Manual.

FOR VEHICLES FITTED WITH LPG FUEL SYSTEM

SPECIFICATIONS

NOTE:

Specifications are subject to change without notice.

ITEM: Mass (weight)	UNIT:Kg	LPG
Curb mass (weight)		895-925

ITEM: Wheel and Suspension		LPG
Tyre size, front and rear		145/80R13
Rim size		13 x 4J
Tire pressures	Front	2.3 Kg/cm ² (32.7psi)
	Rear	2.3 Kg/cm ² (32.7psi)

ITEM: Steering		LPG
Toe-in	Each wheel	3 min ± 5 min
	Total wheel	6 min ± 5 min

ITEM: Capacities (approx.)		
Fuel tank (Petrol)		35 L
LPG Tank (water filling capacity)		28 L (LPG can be filled to 80% of total tank capacity i.e. 22.4 L)

NOTE:

- 1) It is recommended to run the vehicle on petrol mode for 5-10 kms after every 300-500 km run in LPG mode to keep fuel system in good condition.*
- 2) Always keep atleast 5 litres of petrol in petrol tank.*

FIRE EXTINGUISHER (if equipped)
Do's and Don'ts

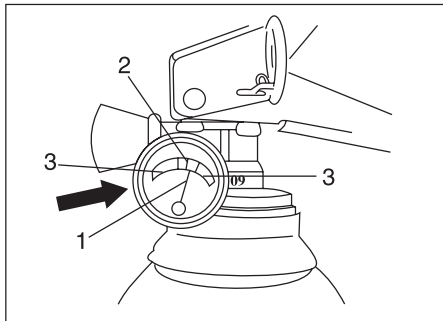

Do's

1. Check pressure gauge periodically. Max charging pressure is 15Kgf/cm² (in green zone (2)).
2. When pressure drops, indicator needle (1) will shift to the red zone (3). Immediately contact the fire extinguisher manufacturer as per the information provided on the fire extinguisher.
3. Get the fire extinguisher serviced only through the manufacturer service centre. Refer the information provided on the fire extinguisher to locate the nearest service centre.
4. Ensure that the Fire extinguisher is always kept at its prescribed position in the vehicle.

5. Refill the fire extinguisher immediately after use.

Don't

- Do not use water for cleaning fire extinguisher. (Use clean cloth for removing dust)
- Do not rely on used or discharged fire extinguisher.

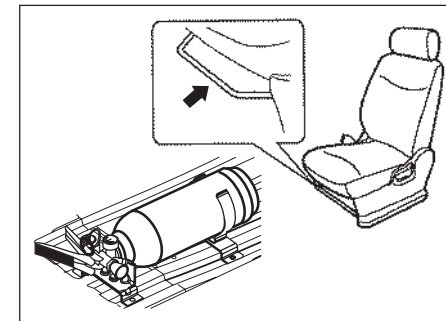

Fire extinguisher is located below co-passenger's seat.

FOR VEHICLES FITTED WITH LPG FUEL SYSTEM

PARTS DESCRIPTION

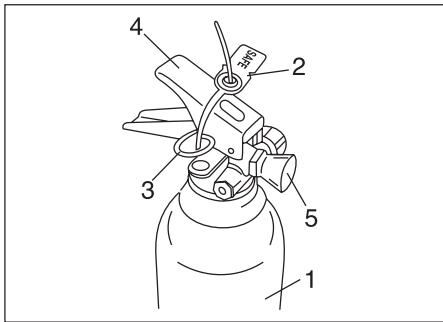

- 1) Fire extinguisher cylinder
- 2) Seal
- 3) Safety Pin
- 4) Lever
- 5) Nozzle

REMOVAL PROCEDURE (from front seat)

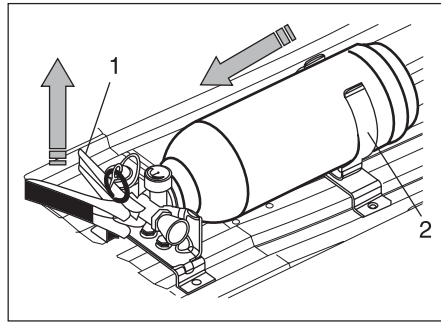

Lift Lever (1) of fire extinguisher slightly upwards and pull the fire extinguisher in the direction as shown in the figure, in order to disengage it from clamp (2).

REMOVAL PROCEDURE (from rear seat)

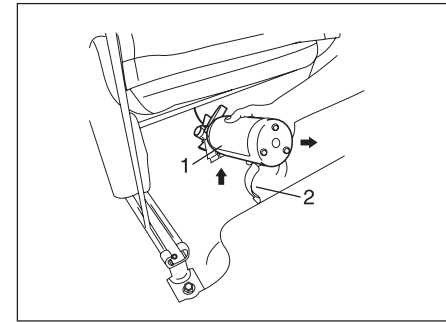

Hold the body of fire extinguisher (1) and lift it up in order to disengage it from clamp (2) as shown. Pull it out towards yourself.

FOR VEHICLES FITTED WITH LPG FUEL SYSTEM

PROCEDURE OF OPERATION

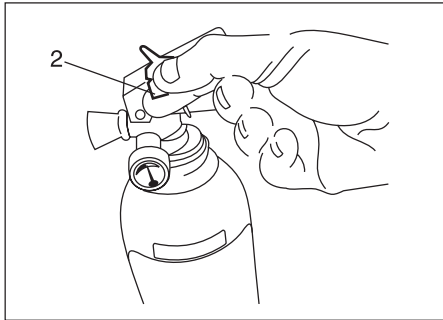

1. Hold the fire extinguisher (1) upright.
2. Break seal (2) by rotating the safety pin (3).

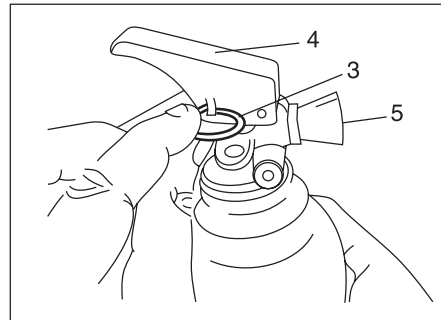

3. Pull Safety pin (3)
4. Squeeze lever (4) and direct the jet from nozzle (5) towards the near edge of the fire with a rapid (fast) sweeping motion.



5. Drive the fire towards the far edge until flames are extinguished.

NOTE:

Fire extinguisher is only meant for small fire caused in vehicle by external source only.

FOR VEHICLES FITTED WITH LPG FUEL SYSTEM

FITMENT PROCEDURE

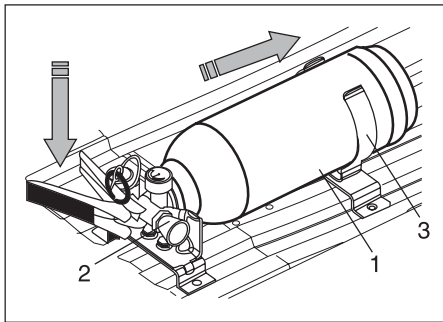

Insert the body of fire extinguisher (1) in to the clamp (3) and place the nozzle (2) carefully downwards, on the clamp

NOTE:

Ensure that the nozzle of fire extinguisher is properly seated on the clamp.

REFILLING SCHEDULES

1. Refilling is necessary after every use.
2. Fire extinguisher needs refilling after every 3 years even if it is not used.